

INDUSTRIAL ROTARY FUEL PUMPS

Product Features

- Industry Standard for Rotary pumps, these are by far the heaviest duty, for severe outdoor use in extreme weather conditions
- Deliver media with a head / lift upto 20'
- Solid cast iron construction, fully CNC machined to close tolerances
- Pump Handle rotates a high quality sintered powder metal 3 Vane Rotor inside a highly finished pumping chamber
- Graphite Vanes are self lubricating & non wearing
- High Quality graphite Seal allows the pump to be used with a wide variety of fluids including Diesel with upto 15% Ethanol blend
- Self Priming operation with discharge up to 38 LPM (10 GPM)
- Supplied complete with 2" Bung, Telescopic Suction Tube with Strainer for use with 15 gallons (50 litre) – 55 gallons (205 litre) barrels
- Also available - Pump with Mechanical Fuel Meter in both litre and gallon versions

WETTED COMPONENTS

Cast Iron, Steel, Graphite, Paper, Polypropylene

DO NOT USE

With Water Based Media

PUMP CHAMBER WITH 3 VANE CONSTRUCTION

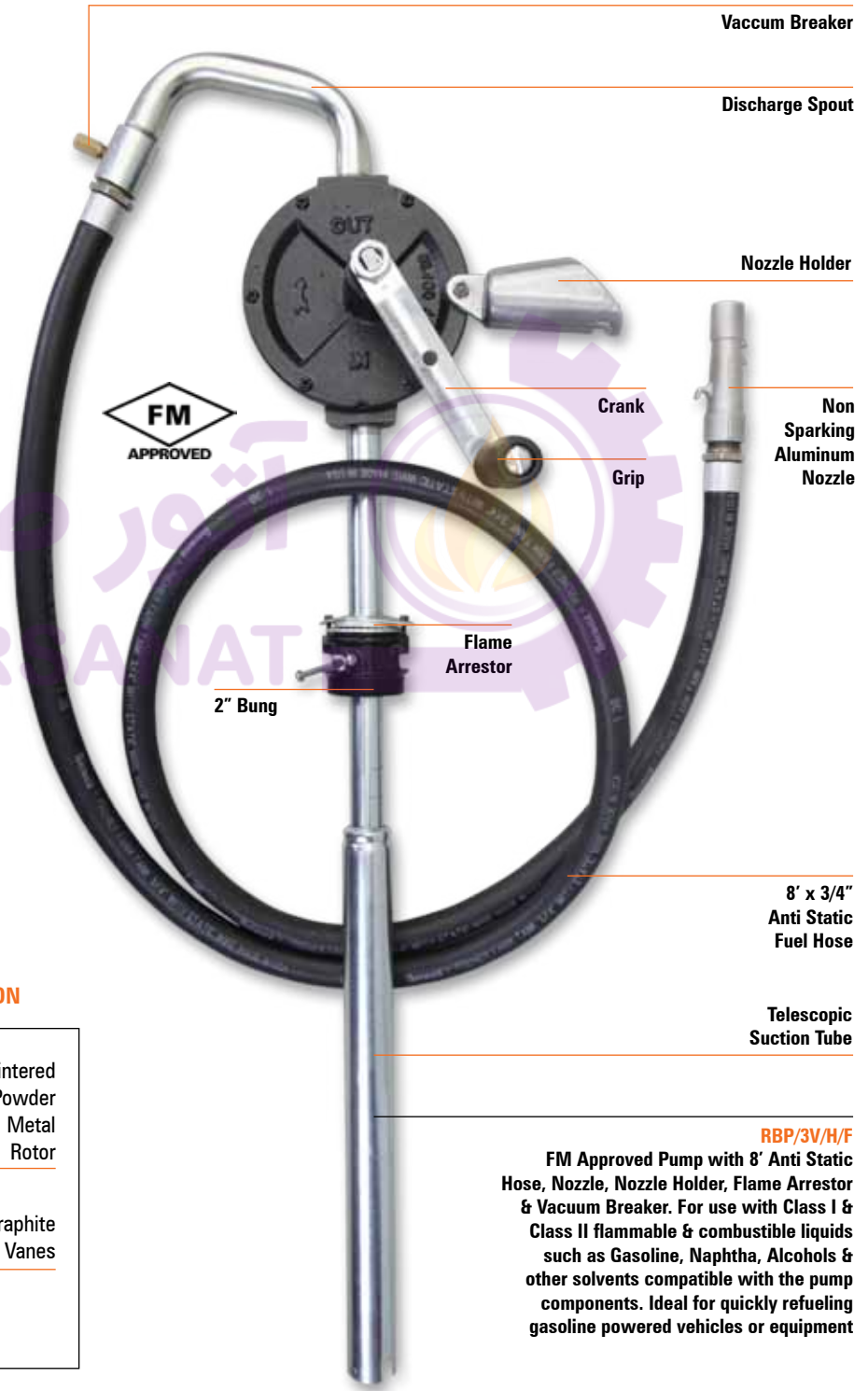
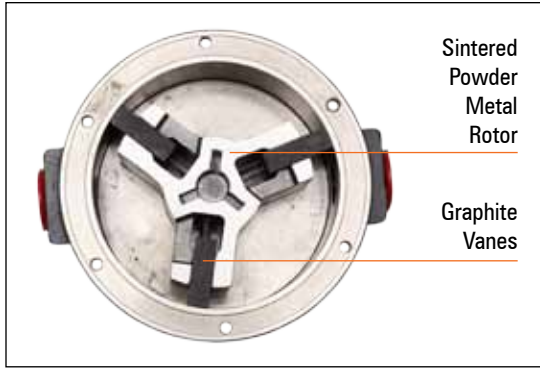

RBP/3V/H/F
FM Approved Pump with 8' Anti Static Hose, Nozzle, Nozzle Holder, Flame Arrestor & Vacuum Breaker. For use with Class I & Class II flammable & combustible liquids such as Gasoline, Naphtha, Alcohols & other solvents compatible with the pump components. Ideal for quickly refueling gasoline powered vehicles or equipment

Variants

RBP/3V

Pump with Steel Discharge Spout for use with Petroleum based fluids, Diesel & Kerosene. Ideal for use with Barrels, drums & tanks for transferring media into smaller containers



RBP/3V/F

FM Approved Pump with Drip pan & Flame Arrestor. For use with Class I & Class II flammable & combustible liquids such as Gasoline, Naphtha, Alcohols & other solvents compatible with the pump components

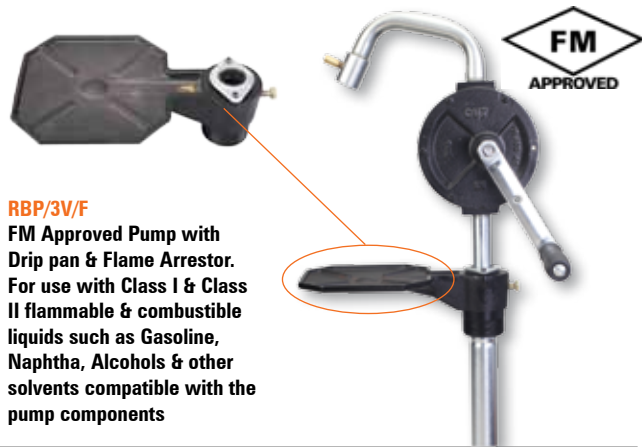

RBP/3V/H

Pump with 8' Antistatic Hose, Nozzle & Nozzle Holder for use with Petroleum base fluids, Diesel & Kerosene. Ideal for use with Barrels, Drums & tanks for quickly refueling Diesel powered vehicles or equipment



RBP/3V/H/MTG

Metered pump with 8' Antistatic Hose, Nozzle & Nozzle Holder for use with Petroleum based fluids, Diesel & Kerosene. Ideal for use with Barrels, Drums & Tanks for refueling Diesel powered vehicles or equipment



Ordering Information

CAT. NR.	ORDERING NR.	DESCRIPTION
* RBP/3V	44080	Steel Spout
* RBP/3V/H	44081	8' Anti-Static Hose, Non-Sparking Aluminum Nozzle & Nozzle Holder
◆ RBP/3V/H/MT	44085	8' Anti-Static Hose, Non-Sparking Aluminum Nozzle, Nozzle Holder & Mechanical Fuel Meter (Litres)
◆ RBP/3V/H/MTG	44087	8' Anti-Static Hose, Non-Sparking Aluminum Nozzle, Nozzle Holder & Mechanical Fuel Meter (Gallons)

FM Approved Pumps

RBP/3V/H/F	44082	8' Anti-Static Hose, Non-Sparking Aluminum Nozzle & Nozzle Holder, Vacuum Breaker & Flame Arrestor
RBP/3V/F	44084	Steel Discharge Spout, Drip Pan with Flame Arrestor
DP/RBP/3V	44083	Replacement Drip Pan only

Service Parts

KIT/RBP/3V	44086	Repair Kit
SA/HOS/RBP/3V	44338	8' x 3/4" Replacement Hose

KIT/RBP/3V

Includes pump head gasket, graphite vanes (3), vane springs (3), shaft nut, packing & packing nut



Key

- * Best Seller
- ◆ New

DELIVERS

38 LPM (10 GPM)



ROTARY BOOSTER PUMP - 3:1

RB-3

Product Features

- Geared Rotary barrel pump with 3 times discharge per rotation. For every complete handle turn, the rotor turns 3 times
- Ideal for use where volume fuel dispensing is needed, such as construction sites, workshop, aviation, farms / ranches, boat etc.
- Die Cast Aluminum construction with sintered gear driven die cast zinc rotor & vanes
- Discharge through 1.8 m of delivery hose with metal nozzle
- Complete with a 3 pc threaded suction tube for use on 15 gallons (50 litre) – 55 gallons (205 litre) barrels

WETTED COMPONENTS

Aluminum, Zinc, Steel, NBR & PVC Nitrile

RECOMMENDED USE

Gasoline, Diesel Fuel & Kerosene

DO NOT USE

With Corrosive liquids, solvents, acids, alkalis etc.

! WARNING

Note that fuels containing Ethanol will cause more frequent replacement of rubber parts

Never operate the pump near fire or source of spark. Some media may be explosive & dangerous to pump

Pump Internals

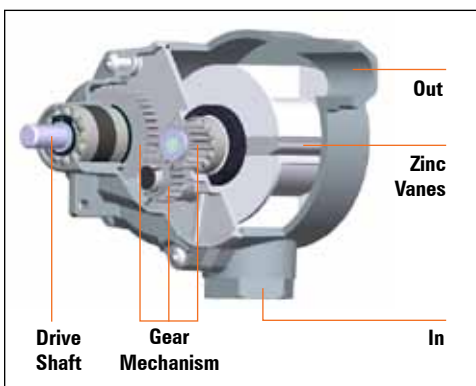

Ordering Information

CAT. NR.	ORDERING NR.
RB/3H	44198

DELIVERS

Dispenses 55 gallon / 205 litres in 3 minutes

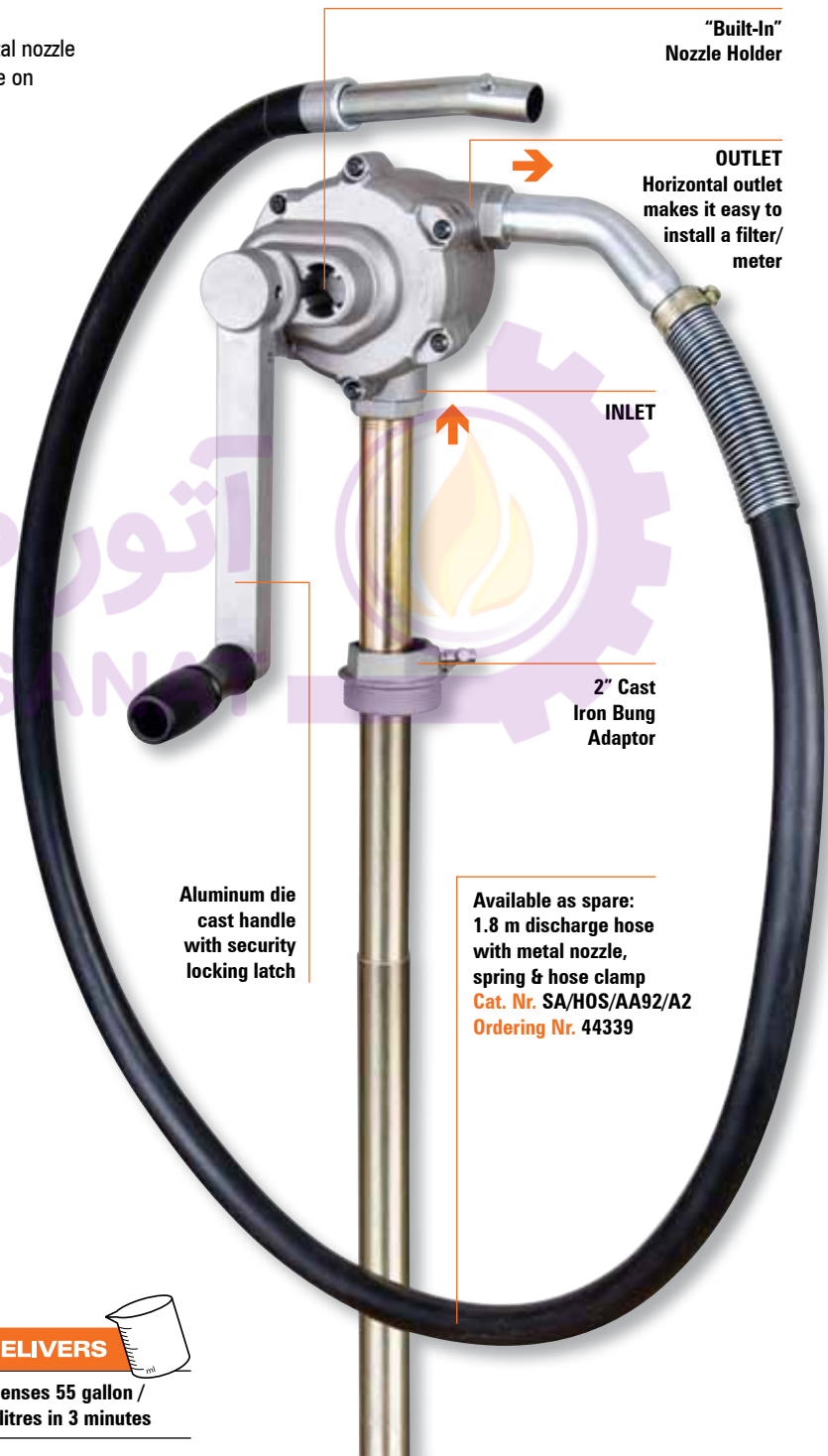

Available as spare:
1.8 m discharge hose with metal nozzle, spring & hose clamp
Cat. Nr. SA/HOS/AA92/A2
Ordering Nr. 44339

ROTARY BARREL PUMP - PROFESSIONAL

RB-1

Product Features

- Rotary barrel pump with Aluminum Die Cast pump body, heavy duty zinc die cast rotor & vanes
- Ideal for use in Industrial & Automotive applications
- Includes a 2" Cast Iron bung adaptor & die cast aluminum handle with security locking latch
- Complete with a 3 pc threaded suction tube for use on 15 gallons (50 litre) – 55 gallons (205 litre) barrels



WETTED COMPONENTS

Aluminum, Zinc, Steel, NBR/Viton & PVC nitrile*

*only for RB/1H

RECOMMENDED USE

Gasoline, Diesel fuel, Kerosene, Antifreeze* & Lubricating oils upto SAE 60

*Only pumps with Viton Seal

DO NOT USE

With Corrosive liquids, Solvents, Acids, Alkalis etc.

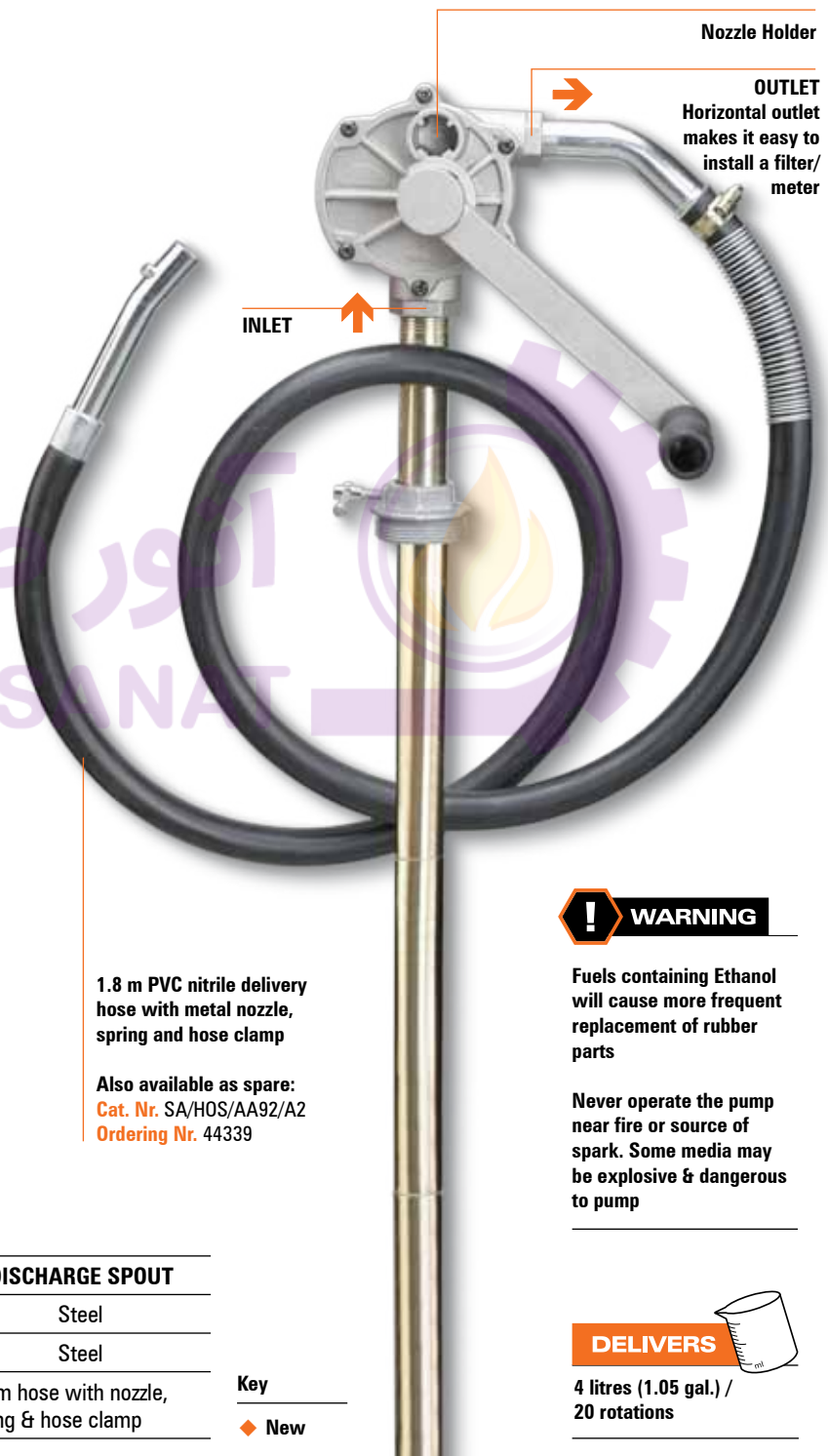

Nozzle Holder

OUTLET
Horizontal outlet makes it easy to install a filter/ meter

INLET

! WARNING

Fuels containing Ethanol will cause more frequent replacement of rubber parts

Never operate the pump near fire or source of spark. Some media may be explosive & dangerous to pump

Variants



RB/1
Pump complete with steel discharge spout

1.8 m PVC nitrile delivery hose with metal nozzle, spring and hose clamp

Also available as spare:
Cat. Nr. SA/HOS/AA92/A2
Ordering Nr. 44339

Ordering Information

CAT. NR.	ORDERING NR.	SEALS	DISCHARGE SPOUT
RB/1	44030	NBR	Steel
◆ RB/1V	44032	VITON	Steel
RB/1H	44031	NBR	1.8 m hose with nozzle, spring & hose clamp

Key

◆ New

DELIVERS

4 litres (1.05 gal.) / 20 rotations



ROTARY BARREL PUMPS

GNB-20 GNB-25

Product Features

- Most popularly used pump worldwide. The Groz version of the Rotary Pump is superior to any other with features such as Dual Directional Operation which allows the pump to both empty, as well as refill containers
- Extremely Heavy Duty & rugged weighing 6.6 kgs (14.5 lbs)
- Pump body is sturdy cast iron with precisely machined cast iron vanes for better draw & smoother delivery
- Fits 15 gallons (50 litre) to 55 gallons (205 litre) barrels
- Comes complete with suction tube, 2" cast iron bung nut & discharge spout

WETTED COMPONENTS

Steel, Cast Iron, NBR/Viton

RECOMMENDED USE

For dispensing Diesel, Kerosene, Heating Oils, Motor Oils, Lubricating Oils (upto SAE 90), and other non-corrosive media

DO NOT USE

With water based media, Antifreeze, Solvents, Acids, and Gasoline etc.

Dual Directional Operation:
Pumps in either direction by a few reverse turns of the handle

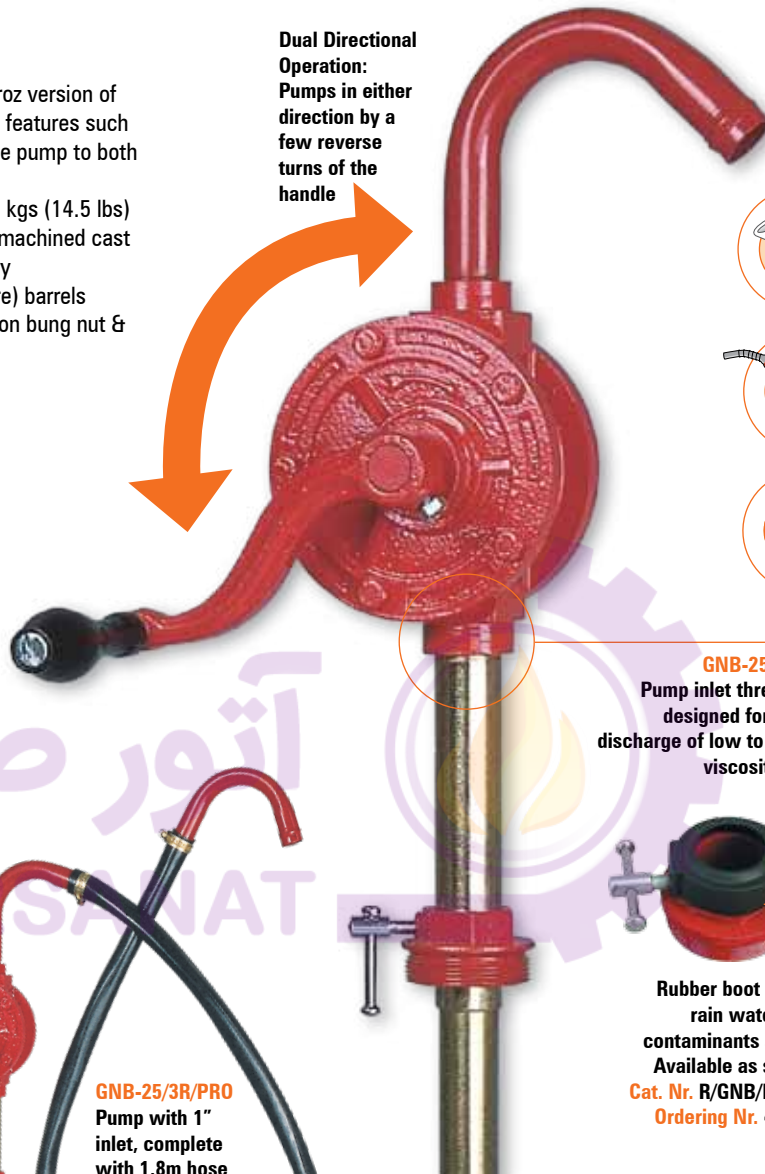

GNB-25/3R/SPL
Pump inlet threaded 1" designed for volume discharge of low to medium viscosity media



Rubber boot keeps rain water and contaminants away.
Available as spare:
Cat. Nr. R/GNB/DN/01
Ordering Nr. 44092

Variants



GNB-20T/SPL
Pump inlet threaded 3/4" designed for use with high viscosity media

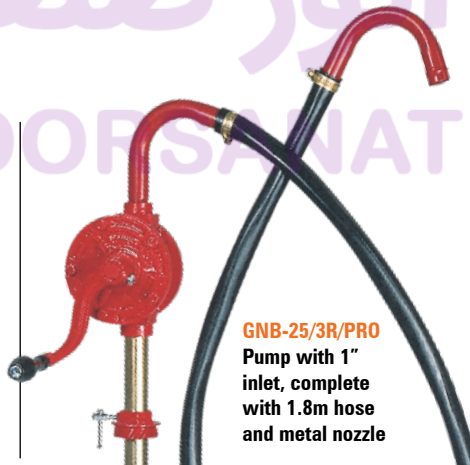

GNB-25/3R/PRO
Pump with 1" inlet, complete with 1.8m hose and metal nozzle

Ordering Information

CAT. NR.	ORDERING NR.	PUMP INLET	SEALS	DISCHARGE SPOUT	SUCTION TUBE
GNB-20T/SPL	44000	3/4"	NBR	Steel	Telescopic
* GNB-25T/SPL	44050	1"	NBR	Steel	Telescopic
* GNB-25/3R/SPL	44052	1"	NBR	Steel	3 pc. Rigid
◆ GNB-25V/3R/SPL	44064	1"	Viton	Steel	3pc. Rigid
GNB-25/3R/PRO	44058	1"	NBR	With 1.8 m hose & metal nozzle	3 pc. Rigid
GNB-25T/PRO	44059	1"	NBR	With 1.8 m hose & metal nozzle	Telescopic

Key * Best Seller ◆ New

DELIVERS



Per 20 turns for Diesel Fuel:
GNB-20: 2.85 litre (0.75 gal.)
GNB-25: 5 litre (1.30 gal.)



USEFUL TIPS!

When using with low viscosity media like Diesel, Kerosene etc., pump should be primed by adding 30 ml of media being pumped or any oil into the pump outlet

ROTARY CHEMICAL PUMP

PRP

Product Features

- Designed for use with media with which a regular cast iron or steel barrel pump cannot be used
- Pump body is made from glass filled polypropylene with Ryton veins
- All seals are from Viton & all pump hardware is Stainless Steel
- Strainer fitted at the suction tube inlet stops contaminants from entering the pump
- Complete with threaded polypropylene suction tube & a choice of two 2" bung adaptors for use on both plastic & metal drums of capacity 15 gallons (50 litre) – 55 gallons (205 litre)

WETTED COMPONENTS

Polypropylene, Ryton, Viton & Stainless Steel

RECOMMENDED USE

For dispensing water based media, antifreeze, **Urea**, **Adblue**, **DEF**, Benzene, Detergents, Glycerine, acids, chemicals etc., in addition to use with all light weight petroleum based products

DO NOT USE

With Acetone, Lacquer, Mineral Oils, Solvents, Turpentine etc.

DELIVERS



5 litres (1.3 gallon)
per 20 turns

Ordering Information

CAT. NR.	ORDERING NR.
PRP/01	44191



Stainless steel hardware

Bung with 2" threads

Strainer

