



AODD PUMPS
PNEUMATIC METERING PUMPS
PULSATION DAMPENERS



...there's
something new
in the air...



**ASTRA RANGE
AODD
PUMPS**

page 13



**ASTRAFOOD
FOR FOOD AND BEVERAGE
APPLICATIONS**

page 29



**MISTRAL
RANGE BIG
AODD PUMPS**

page 35



**AIRSATURN
AODD
PUMPS**

page 39



**PNEUMATIC
METERING
PUMPS**

page 43

**SELENE RANGE
PULSATION
DAMPENERS**

page 50

ACCESSORIES

page 54

INDEX



**QUALITY EXPERIENCE
INNOVATION
SINCE 1975**

ARGAL® boasts forty years of activity in the **invention and production of pumps** made of thermoplastic material, **compounds and corrosion-resistant metal alloys**. During the past decade significant efforts were directed to research and development on the entire production and such an effort resulted in pump ranges completely new or renovated both in terms of mechanics and hydraulics systems.

The main mission of **ARGAL®** is continuous and constant technological improvement, along the path of **innovation instead of emulation**, with the aim to offer always the best technical performance and engineering obtaining the leadership in performance while providing appropriate responses to the needs of market dynamics always realizing a “State-of-the-art” quality.

Today the company has a wide range of pumps in various constructions for industrial applications requiring temperatures ranging from -40° C to +130°C, with load capacities up to 1600 m³/h-head over the 100 m. **ARGAL®** also offers the most complete italian range of AODD pumps (from ¼” to 4”) with metallic or plastic solutions to satisfy the most various market demand.

All is **certified ISO 9001:2000 according to Vision ISO 9001:2000 rule**. We strongly want to offer a wide production program with high quality pumps ranges and really competitive prices.



Why an AODD pump?

Self-priming

The pump design allows high suction lift even at dry-start and with heavier fluids.

Shear Sensitive

The gentle pneumatic movement makes the ARGALAIR an excellent choice for shear sensitive fluids.

Safe

ARGALAIR pump is operated by compressed air and are intrinsically safe.

Able to run dry

Portable and simple installation

ARGALAIR pump can be easily transported to the application site. Simply connect your air supply line and liquid lines and the pump is ready to perform. There is no complex control for installing and operating.

Submersible

If external material are compatible, then the pump can run submerged in the liquid by simply running the exhaust line above the liquid level.

Variable flow rate and discharge pressure

ARGALAIR offers the ability too vary flow and discharge pressure up to 120 psi with a simple adjustment of the air supply.

Handles a wide variety of fluids with high solids content

No close fitting or rotating parts so liquids with high solids content can be easily pumped, actually any liquids with max of 90% solids.

Dead-head

Because the discharge pressure can never exceed air inlet pressure, the discharge line can be closed with no damage or wear. The pump will simply slow down and stop.

... operating principles

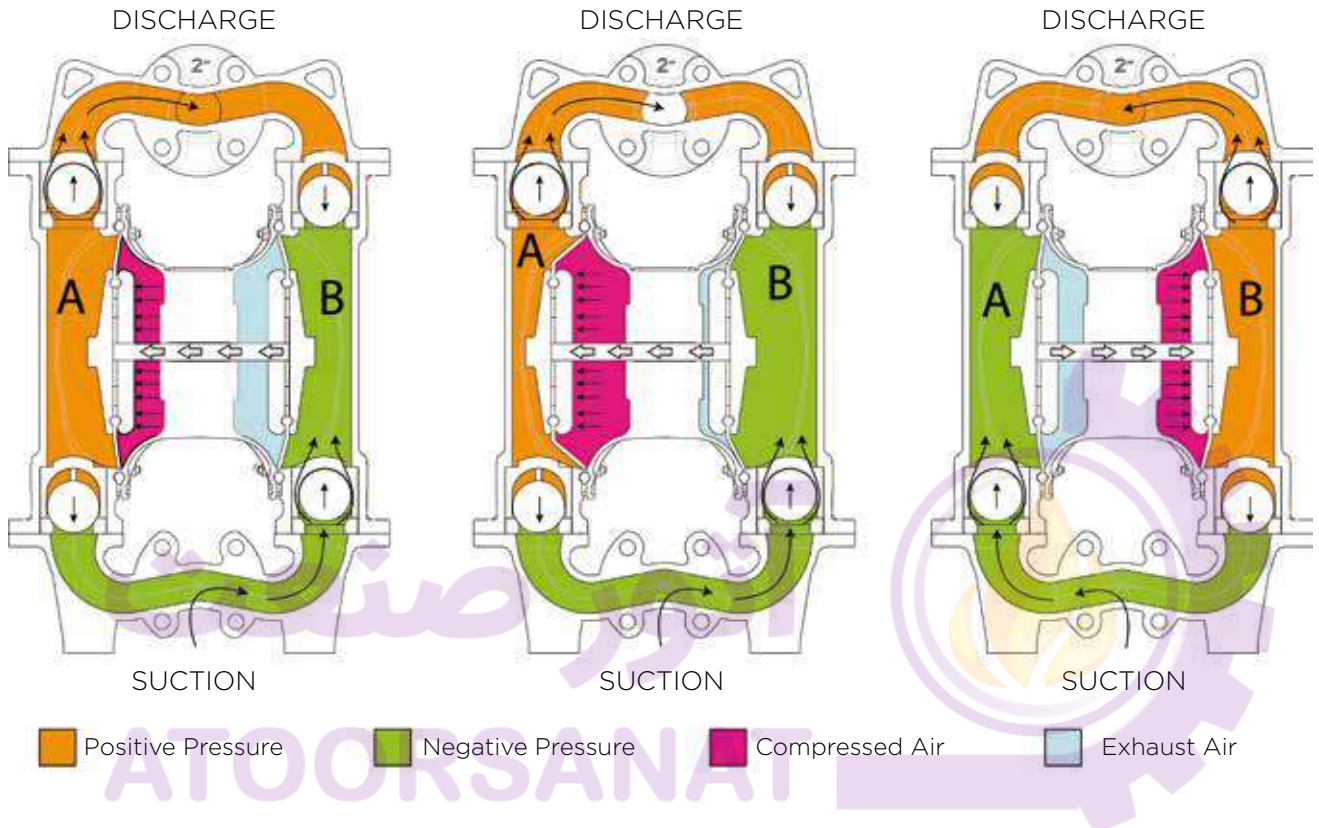

The pneumatic distribution system sends compressed air behind one of the two diaphragms (A), which pushes the fluid towards the delivery circuit. Simultaneously, the opposite diaphragm (B) is in the intake phase as it is dragged by the shaft that connects it to diaphragm (A), under pressure; air presents behind diaphragm (B) is discharged into the environment through the flow rate regulator on the pump, while a pressure drop is created in the fluid chamber which 'sucks' the fluid from the suction circuit. When the diaphragm (A), under pressure, reaches the stroke limit, the distributor switches the two inputs to the chamber on the diaphragms air side, putting diaphragm (B) under pressure and diaphragm (A), in discharge. When the pump reaches its original starting point, each diaphragm has carried out one air discharge stroke and one fluid delivery stroke. This sequence of movements makes up a complete pumping cycle.

Why choosing an ARGALAIR AODD pump?

... high-quality materials

Our AODD pumps are obtained using **the best thermoplastic polymers of Italy.**

Realised with injected polymers reinforced with composite fiber, AOOD pumps guarantee an optimal mechanical seal as well as a notable corrosive resistance.

Solutions are in fiberglass polypropylene (**PP+G**) and in polyvinylidene fluoride reinforced with carbon fiber (**PVDF+C**) and are also available in ATEX ZONE 1 applications version, for strict and dangerous areas.

The metallic variations can be distinguished for their reliability and low-costs versions in **aluminium and AISI 316** of the ASTRA range.

Whereas the **AISI 316L** and exotic alloys (**bronze, duplex**) versions of the MISTRAL range are focused on robustness and chemical resistance.

... a complete range

A "custom-made production series" cover the entire market requirements but not only: ASTRA and MISTRAL ranges offer various alternatives for the most requested dimensions.

For the compact sizes **from 1/4" to 1/2"**, Argal submits six models corresponding to the different materials.

Four other models are available for the medium sizes until 1". Two versions are realised for the **1 1/2" as well as for the 2"**.

Moreover, we are part of the ring of few world designers to offer large sizes **from 3" to 4"**.

Last but not least, Argal designed and produced a range of economically and energetically advantageous pumps capable of sensible air consumption savings with same dimensions but different performances at an affordable price.

... Our experience into the corrosive and abrasive world

With our forty-year experience in corrosive and abrasive applications, we are specialists in design and problem-solving. Our goal is to offer a wide production program with high-quality and competitive prices solutions.



WETTED PARTS 1	DIAPHRAGM 2	VALVE BALLS 3	VALVE SEAT 4	APPLICATIONS
PP+Glass	TEFLON®	TEFLON®	PP	Great chemical resistance. Optimal aspiration dry and silent. Adapted to paintings
PP+Glass	TEFLON®	AISI 316	AISI 316	High viscosity products. Glues and resins
PP+Glass	Santoprene®	EPDM	PE	High abrasion resistance
Alluminium	Keyflex®	TEFLON®	Alluminium	Economic solution adapted to pump hydrocarbons
Alluminium	TEFLON®	TEFLON®	Alluminium	Solvents. Inks. Painting
PVDF+Carbon	TEFLON®	TEFLON®	PVDF	Aggressive acids. High temperatures $\geq 80^{\circ}\text{C}$
AISI 316	TEFLON®	TEFLON®	AISI 316	Aggressive acids. High temperatures $\leq 110^{\circ}\text{C}$
AISI 316	TEFLON®	AISI 316	AISI 316	Very high-viscosity and high temperatures
AISI 316 Polished	TEFLON®	TEFLON®	AISI 316 Polished	Food. Cosmetic (spheres version and polished AISI 316 polished seats for high viscosity products)
AISI 316 Polished	TEFLON®	AISI 316 Polished	AISI 316 Polished	Food. Cosmetic. High viscosity.

MATERIALS

PP Polypropylene	UPPE Ultra High Molecular Weight Polyethylene	FRP Fiberglass		
PVDF Polyvinylidene Fluoride	PTFE Poly Tetra Fluoro Ethylene (Teflon®)	POMc Polyoxymethylene		
Alu Aluminium	DX Alloy Duplex	AISI 316 L Stainless Steel (low Carbon)	AISI 316 Stainless Steel	BR Bronze

TECHNOLOGY

 Self-priming	 Submersible
--	---

TEMPERATURES (°C)

								
--	--	--	--	--	--	--	--	--

CERTIFICATION/WARRANTY

 Atex	 Food and Drug Administration
--	--

WARRANTY

 12 months	 24 months	 60 months
---	---	---

SERIES	WETTED PARTS	DIAPHRAGMS	BALL VALVE	BALL SEATS	GASKETS
WR	PP (GFR)	NT NBR & PTFE	T PTFE	P PP	T PTFE
FC	PVDF (CFF)	HT KEYFLEX® & PTFE	S AISI 316	S AISI 316	D EPDM
DL	POMc (GFR)	MT SANTOPRENE® & PTFE	D EPDM	Z PE (UHMW)	V FKM
AL	ALUMINIUM	M SANTOPRENE®	N NBR	K PVDF	N NBR
SS	AISI 316	H KEYFLEX®		O POMc	
SP	AISI 316 (FDA)	D EPDM RUBBER		A ALUMINIUM	

ASTRA

ASTRA range is ideal for the most **various industrial applications**.

This newest project is made with the very last technologies to guarantee a major reliability of the pump: lifetime and diaphragms are improved, maintenance operations are reduced and it has an enviable quality/price offer.

ASTRA COMPACT range is composed of smaller sizes made for **OEM customers**, guaranteeing the major constructive simplicity and taking up the minimal amount of space.



Zone 2









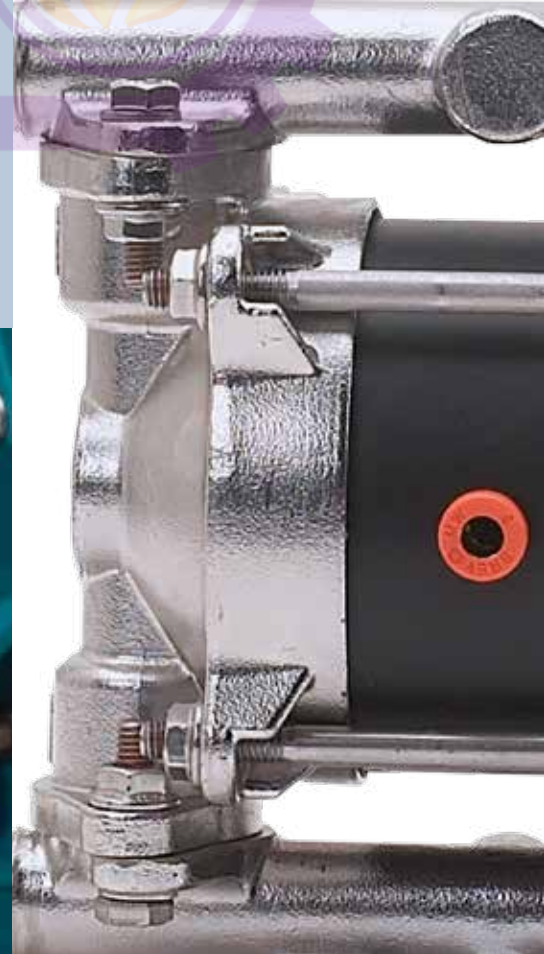



MAIN

APPLICATIONS

- Chemical industry
- Automotive
- Textile
- Graphic
- Leather tanning
- Electroplating ceramics
- Paints
- Ink
- Paper
- Construction
- Water treatment and Waste treatment



ASTRA (*)	Flow rate (l/min")	Ports (inch)	Materials	Solids (mm)	The best selling
25-09 	9	1/4"	• POMc • PP • PVDF	2,5	<ul style="list-style-type: none"> • WR NT TPD • FC NT TKT • DL NT TOT • WR NT TPT • FC NT TKV
38-18 	18	3/8"	• POMc • PP • PVDF • AISI 316	3	<ul style="list-style-type: none"> • WR HT TPD • FC MT TKT • DL HT TOT • SS HT TST • WR HT TPT • FC MT TKV • DL HT TOV
50-30 	30	1/2"		3,5	<ul style="list-style-type: none"> • WR NT TPD • WR M-DZD • FC NT TKT • DL HT TAT • SS HT TST • WR NT TPT • WR M-TPD • FC NT TKV • DL HT TAV • SS HT TSV
50-50 	50	1/2"	• PP • PVDF • ALU • AISI 316	3,5	<ul style="list-style-type: none"> • WR HT TPD • WR M-DZD • FC NT TKT • AL HT TAT • SS HT TST • WR HT TPT • WR M-TPD • FC NT TKV • AL HT TAV • SS HT TS
50-65 	65	1/2"		3,5	
75-100 	100	3/4"		3,5	
100-100 	100	1"	• PP • PVDF	3,5	
100-160 	160	1"	7,5		
125-250 	250	1 1/4"	• PP • PVDF • ALU • AISI 316	7,5	
150-500 	500	1 1/2"		8,5	
200-650 	650	2"		8,5	

(*) Max pressure 8 bar

ASTRA COMPACT

DDA 25-09



PP $+60^{\circ}$ -5 0,7 Kg + 0,1 Kg
 Pump Packaging

POMc $+80^{\circ}$ -10° 0,8 Kg + 0,1 Kg
 Pump Packaging

PVDF $+80^{\circ}$ -10° 0,8 Kg + 0,1 Kg
 Pump Packaging

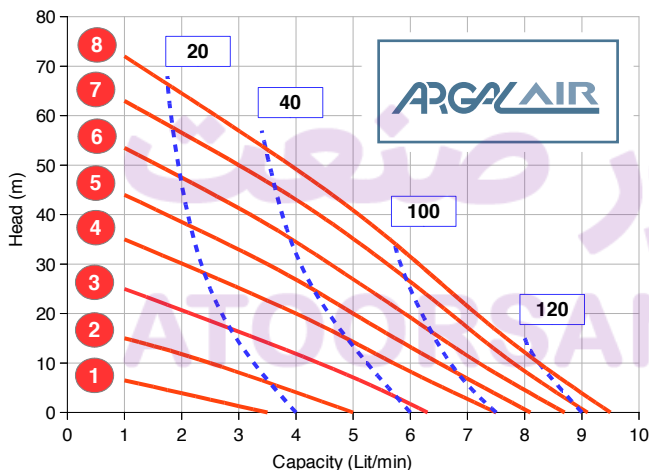

TECHNICAL DATA	
Fluid connections	1/4" BSP • NPT*
Air connection	4 mm
Max flow rate	9 l/m'
Max air pressure	8 bar
Max delivery head	80 mca
Max suction lift dry	3 mca
Max suction lift wet	9,8 mca
Max size solids	2,5 mm
Noise level	62 dB(A)
Max viscosity	6.000 cPs

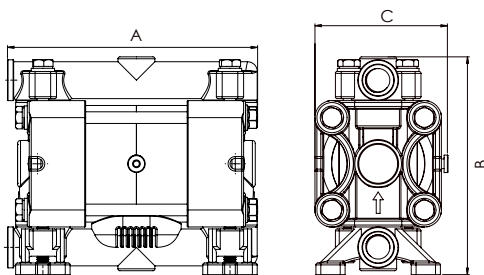

DIMENSIONS (mm)	
PP	A 129 B 112 C 68
PVDF	A 129 B 112 C 68
POMc	A 129 B 112 C 68

COMPOSITION	
Wetted parts	• PP • PVDF • POMc
Diaphragms	• NBR+PTFE
Valve Balls	• PTFE • AISI 316
Valve Seats	• PP • PVDF • POMc
Gaskets	• EPDM • VITON • NBR • PTFE

Connections scheme page 28

* Optional

ASTRA COMPACT

DDA 38-18



PVDF 1,4 Kg + 0,2 Kg Pump Packaging	PP 1,1 Kg + 0,2 Kg Pump Packaging	AISI 316 2,1 Kg + 0,2 Kg Pump Packaging	POMc 1,4 Kg + 0,2 Kg Pump Packaging
--	--	--	--

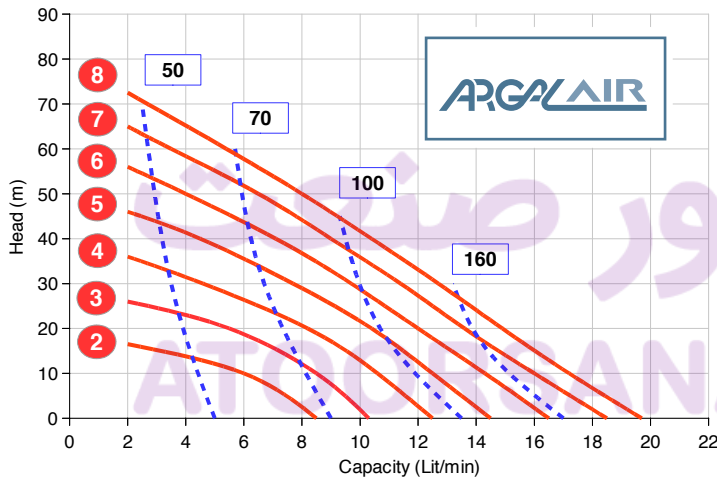

Air Pressure main supply Air consumption

TECHNICAL DATA	
Fluid connections	3/8" BSP • NPT*
Air connection	6 mm
Max flow rate	18 l/m'
Max air pressure	8 bar
Max delivery head	80 mca
Max suction lift dry	6 mca
Max suction lift wet	9,8 mca
Max size solids	3 mm
Noise level	65 dB(A)
Max viscosity	12.000 cPs

DIMENSIONS (mm)	
PP	A 146 B 96 C 164
PVDF	A 146 B 96 C 164
POMc	A 146 B 96 C 164
AISI 316	A 148 B 92 C 153

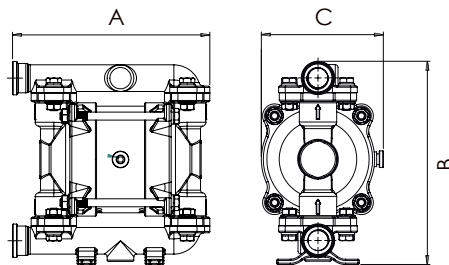

COMPOSITION	
Wetted parts	• PP • PVDF • POMc • AISI 316
Diaphragms	• HYTREL + PTFE • SANTOPRENE + PTFE • HYTREL • SANTOPRENE
Valve Balls	• PTFE • AISI 316
Valve Seats	• PP • PVDF • POMc • AISI 316
Gaskets	• EPDM • VITON • NBR • PTFE

Connections scheme page 28

* Optional

ASTRA COMPACT

DDA 50-30

ARGALAIR

آتور صنعت
ATOORSANAT



PP 1,2 Kg + 0,2 Kg Pump Packaging	PVDF 1,5 Kg + 0,2 Kg Pump Packaging	POMc 1,5 Kg + 0,2 Kg Pump Packaging	AISI 316 2,2 Kg + 0,2 Kg Pump Packaging
--	--	--	--

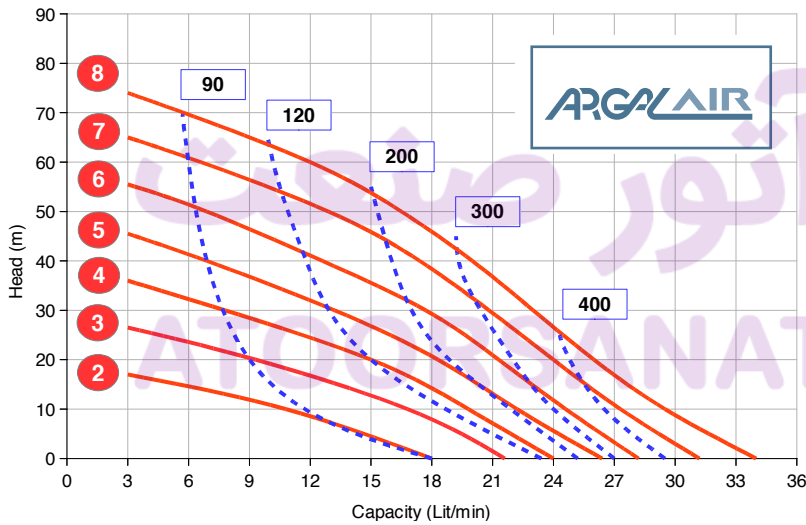

Air Pressure main supply Air consumption

TECHNICAL DATA	
Fluid connections	1/2" BSP • NPT* • FLANGED* DN15
Air connection	6 mm
Max flow rate	30 l/m'
Max air pressure	8 bar
Max delivery head	80 mca
Max suction lift dry	5 mca
Max suction lift wet	9,8 mca
Max size solids	3,5 mm
Noise level	65 dB(A)
Max viscosity	15.000 cPs

DIMENSIONS (mm)	
PP	A 177 B 105 C 183
PVDF	A 177 B 105 C 183
POMc	A 177 B 105 C 183
AISI 316	A 182 B 104 C 190

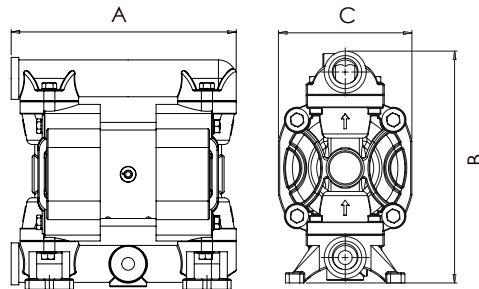

COMPOSITION	
Wetted parts	• PP • PVDF • POMc • AISI 316
Diaphragms	• HYTREL + PTFE • SANTOPRENE + PTFE • HYTREL • SANTOPRENE
Valve Balls	• PTFE • AISI 316 • EPDM • NBR
Valve Seats	• PP • PVDF • POMc • AISI 316 • UPPE
Gaskets	• EPDM • VITON • NBR • PTFE

Connections scheme page 28

* Optional

ASTRA COMPACT

DDA 50-50



PVDF	+80°	-10°	4,3 Kg + 0,3 Kg	Alu	+80°	-10°	4,2 Kg + 0,3 Kg	AISI 316	+80°	-10°	6 Kg + 0,3 Kg	PP	+60°	-5°	3,6 Kg + 0,3 Kg
Pump Packaging				Pump Packaging				Pump Packaging				Pump Packaging			

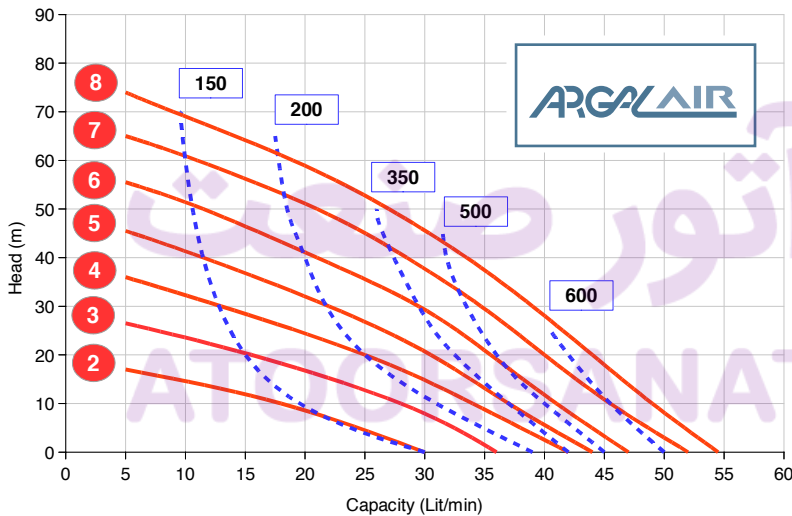

bar Air Pressure main supply **NI/min** Air consumption

TECHNICAL DATA	
Fluid connections	1/2" BSP • NPT* • FLANGED* DN15
Air connection	1/4" BSP
Max flow rate	50 l/m'
Max air pressure	8 bar
Max delivery head	80 mca
Max suction lift dry	6 mca
Max suction lift wet	9,8 mca
Max size solids	3,5 mm
Noise level	68 dB(A)
Max viscosity	20.000 cPs

DIMENSIONS (mm)	
PP	A 222 B 156 C 233
PVDF	A 222 B 156 C 233
ALU	A 225 B 156 C 230
AISI 316	A 225 B 156 C 230

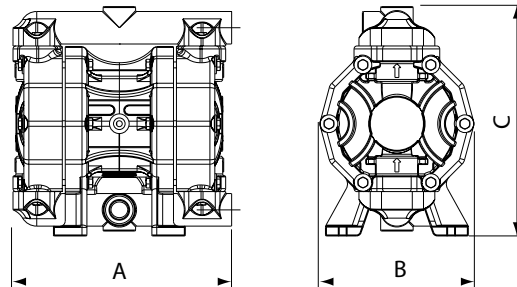

COMPOSITION	
Wetted parts	• PP • PVDF • ALU • AISI 316
Diaphragms	• HYTREL + PTFE • SANTOPRENE + PTFE • HYTREL • SANTOPRENE
Valve Balls	• PTFE • AISI 316 • EPDM • NBR
Valve Seats	• PP • PVDF • ALU • AISI 316 • UPPE
Gaskets	• EPDM • VITON • NBR • PTFE

Connections scheme page 28

* Optional

ASTRA DDA 50-65

ARGALAIR

آتور صنعت
ATOORSANAT



PVDF	+80°	-10°	6,1 Kg + 0,4 Kg	Alu	+80°	-10°	5,5 Kg + 0,4 Kg	AISI 316	+80°	-10°	7,8 Kg + 0,4 Kg	PP	+60°	-5°	5,3 Kg + 0,4 Kg
Pump Packaging				Pump Packaging				Pump Packaging				Pump Packaging			

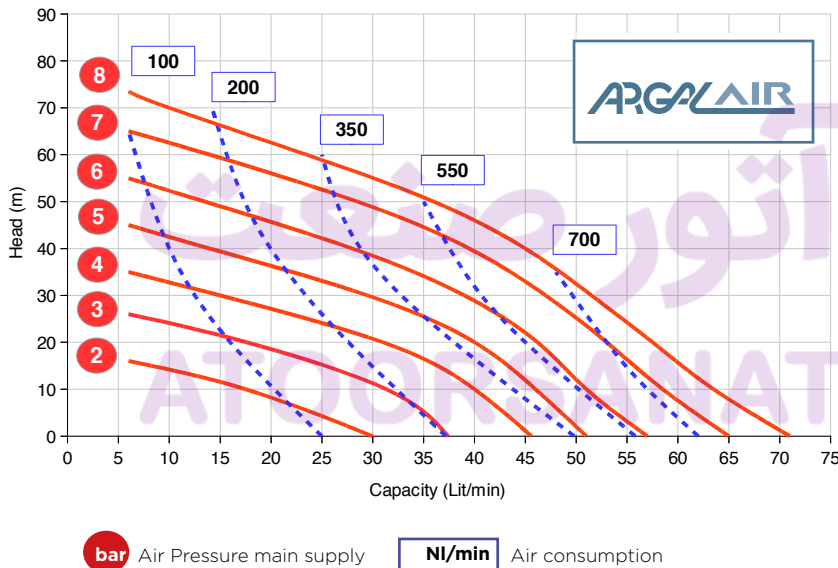

TECHNICAL DATA	
Fluid connections	½" BSP • NPT* • FLANGED* DN15
Air connection	¾" BSP
Max flow rate	65 l/m'
Max air pressure	8 bar
Max delivery head	80 mca
Max suction lift dry	6 mca
Max suction lift wet	9,8 mca
Max size solids	3,5 mm
Noise level	72 dB(A)
Max viscosity	25.000 cPs

DIMENSIONS (mm)	
PP	A 265 B 175 C 245
PVDF	A 265 B 175 C 245
ALU	A 265 B 175 C 245
AISI 316	A 250 B 175 C 250

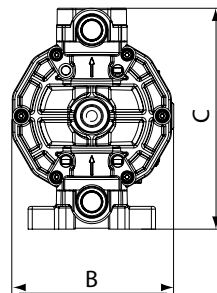
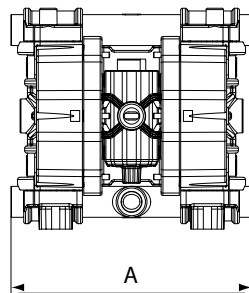

COMPOSITION	
Wetted parts	• PP • PVDF • ALU • AISI 316
Diaphragms	• HYTREL + PTFE • SANTOPRENE + PTFE • HYTREL • SANTOPRENE • EPDM • NBR
Valve Balls	• PTFE • AISI 316 • EPDM • NBR
Valve Seats	• PP • PVDF • ALU • AISI 316 • UPPE
Gaskets	• EPDM • VITON • NBR • PTFE

Connections scheme page 28

* Optional

ASTRA DDA 75-100



PVDF 6,2 Kg + 0,4 Kg Pump Packaging	Alu 5,7 Kg + 0,4 Kg Pump Packaging	AISI 316 7,8 Kg + 0,4 Kg Pump Packaging	PP 5,4 Kg + 0,4 Kg Pump Packaging
--	---	--	--

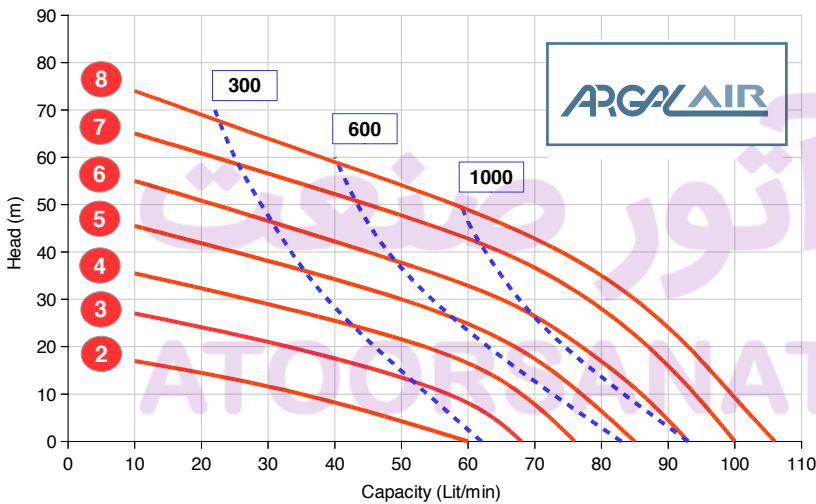

Air Pressure main supply Air consumption

TECHNICAL DATA	
Fluid connections	3/4" BSP • NPT* • FLANGED* DN20
Air connection	3/8" BSP
Max flow rate	100 l/m'
Max air pressure	8 bar
Max delivery head	80 mca
Max suction lift dry	6 mca
Max suction lift wet	9,8 mca
Max size solids	3,5 mm
Noise level	72 dB(A)
Max viscosity	25.000 cPs

DIMENSIONS (mm)	
PP	A 265 B 175 C 245
PVDF	A 265 B 175 C 245
ALU	A 265 B 175 C 245
AISI 316	A 250 B 175 C 250

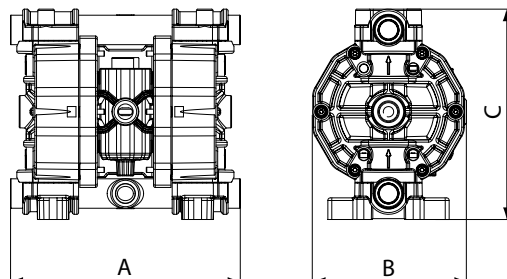

COMPOSITION	
Wetted parts	<ul style="list-style-type: none"> PP • PVDF ALU • AISI 316
Diaphragms	<ul style="list-style-type: none"> HYTREL + PTFE SANTOPRENE + PTFE HYTREL SANTOPRENE EPDM • NBR
Valve Balls	<ul style="list-style-type: none"> PTFE • AISI 316 EPDM • NBR
Valve Seats	<ul style="list-style-type: none"> PP • PVDF • ALU AISI 316 • UPPE
Gaskets	<ul style="list-style-type: none"> EPDM • VITON NBR • PTFE

Connections scheme page 28

* Optional

ASTRA

DDA 100-100

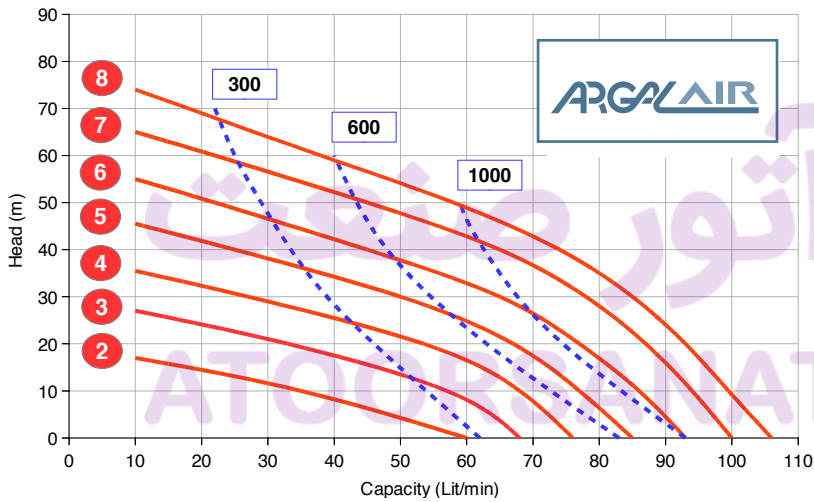

bar Air Pressure main supply **NI/min** Air consumption

TECHNICAL DATA	
Fluid connections	1" BSP • NPT* • FLANGED* DN25
Air connection	3/8" BSP
Max flow rate	100 l/m'
Max air pressure	8 bar
Max delivery head	80 mca
Max suction lift dry	6 mca
Max suction lift wet	9,8 mca
Max size solids	3,5 mm
Noise level	72 dB(A)
Max viscosity	25.000 cPs

DIMENSIONS (mm)	
PP	A 265 B 175 C 245
PVDF	A 265 B 175 C 245

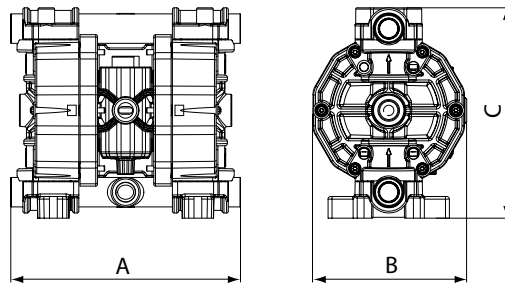

COMPOSITION	
Wetted parts	• PP • PVDF
Diaphragms	• HYTREL + PTFE • SANTOPRENE + PTFE • HYTREL • SANTOPRENE • EPDM • NBR
Valve Balls	• PTFE • SS • EPDM • NBR
Valve Seats	• PP • PVDF • AISI 316 • UPPE
Gaskets	• EPDM • VITON • NBR • PTFE

Connections scheme page 28

* Optional

ASTRA

DDA 100-160

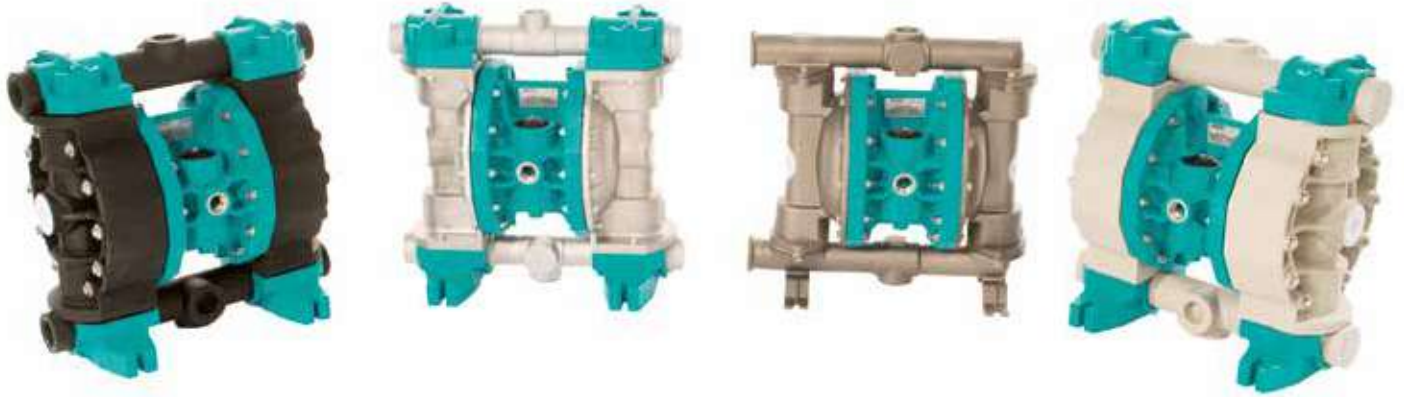

PVDF	+80°	-10°	13,4 Kg + 0,7 Kg	Alu	+80°	-10°	12,4 Kg + 0,7 Kg	AISI 316	+80°	-10°	16,9 Kg + 0,7 Kg	PP	+60°	-5°	11 Kg + 0,7 Kg
Pump Packaging				Pump Packaging				Pump Packaging				Pump Packaging			

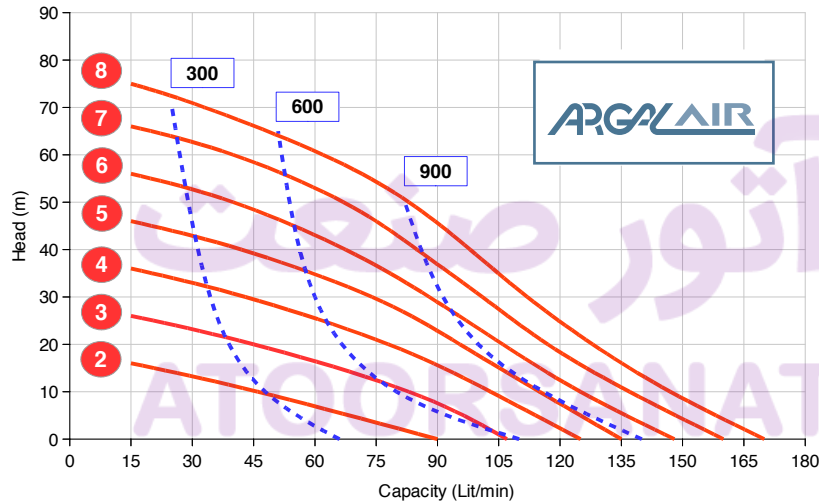

bar Air Pressure main supply **NI/min** Air consumption

TECHNICAL DATA	
Fluid connections	1" BSP • NPT* • FLANGED* DN25
Air connection	½" BSP
Max flow rate	160 l/m'
Max air pressure	8 bar
Max delivery head	80 mca
Max suction lift dry	6 mca
Max suction lift wet	9,8 mca
Max size solids	7,5 mm
Noise level	75 dB(A)
Max viscosity	35.000 cPs

DIMENSIONS (mm)	
PP	A 370 B 222 C 370
PVDF	A 370 B 222 C 370
ALU	A 370 B 222 C 364
AISI 316	A 360 B 222 C 346

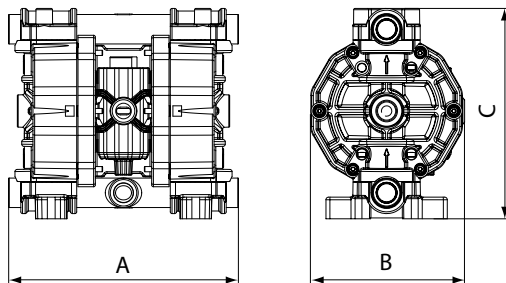

COMPOSITION	
Wetted parts	• PP • PVDF • ALU • AISI 316
Diaphragms	• HYTREL + PTFE • SANTOPRENE + PTFE • HYTREL • SANTOPRENE • EPDM • NBR
Valve Balls	• PTFE • AISI 316 • EPDM • NBR
Valve Seats	• PP • PVDF • ALU • AISI 316 • UPPE
Gaskets	• EPDM • VITON • NBR • PTFE

Connections scheme page 28

* Optional

ASTRA DDA 125-250

ARGALAIR

آتور صنعت
ATOORSANAT



PVDF 13,9 Kg + 0,7 Kg Pump Packaging	PP 11,1 Kg + 0,7 Kg Pump Packaging	Alu 12,5 Kg + 0,7 Kg Pump Packaging	AISI 316 17 Kg + 0,7 Kg Pump Packaging
---	---	--	---

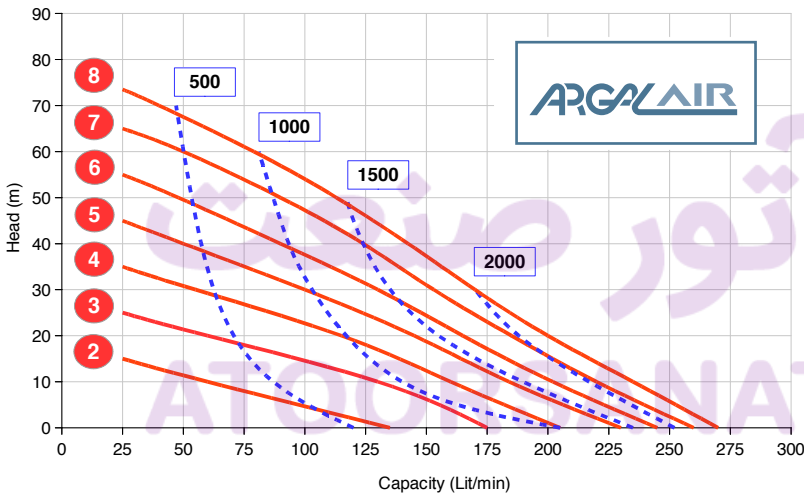

Air Pressure main supply Air consumption

TECHNICAL DATA	
Fluid connections	1¼" BSP • NPT* • FLANGED* DN32
Air connection	½" BSP
Max flow rate	250 l/m'
Max air pressure	8 bar
Max delivery head	80 mca
Max suction lift dry	6 mca
Max suction lift wet	9,8 mca
Max size solids	7,5 mm
Noise level	75 dB(A)
Max viscosity	35.000 cPs

DIMENSIONS (mm)	
PP	A 370 B 222 C 370
PVDF	A 370 B 222 C 370
ALU	A 370 B 222 C 364
AISI 316	A 360 B 222 C 346

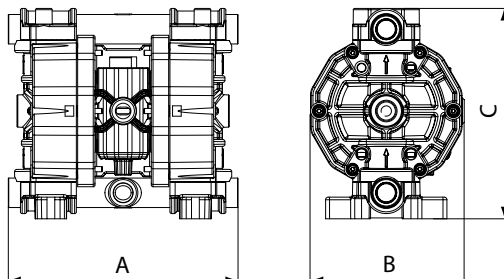

COMPOSITION	
Wetted parts	• PP • PVDF • ALU • AISI 316
Diaphragms	• HYTREL + PTFE • SANTOPRENE + PTFE • HYTREL • SANTOPRENE • EPDM • NBR
Valve Balls	• PTFE • AISI 316 • EPDM • NBR
Valve Seats	• PP • PVDF • ALU • AISI 316 • UPPE
Gaskets	• EPDM • VITON • NBR • PTFE

Connections scheme page 28

* Optional

ASTRA DDA 150-500

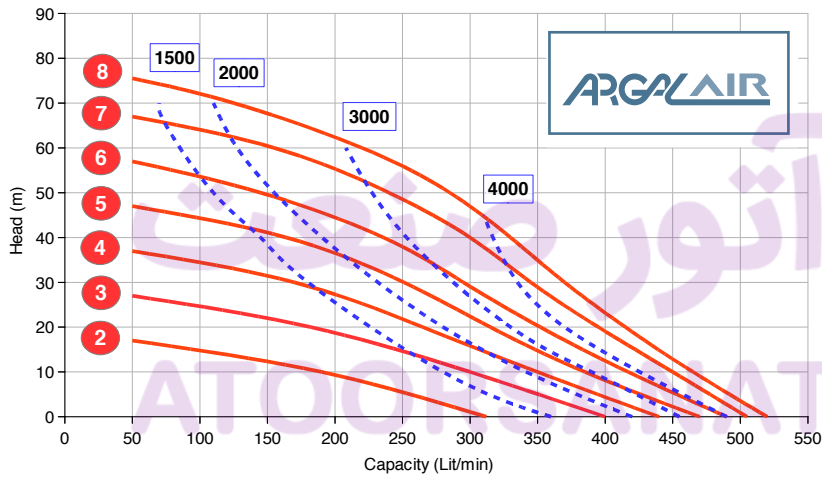

bar Air Pressure main supply **NI/min** Air consumption

TECHNICAL DATA	
Fluid connections	1½" BSP • NPT* • FLANGED* DN40
Air connection	¾" BSP
Max flow rate	500 l/m'
Max air pressure	8 bar
Max delivery head	80 mca
Max suction lift dry	5 mca
Max suction lift wet	9,8 mca
Max size solids	8,5 mm
Noise level	78 dB(A)
Max viscosity	50.000 cPs

DIMENSIONS (mm)	
PP	A 595 B 345 C 565
PVDF	A 595 B 345 C 565
ALU	A 595 B 345 C 560
AISI 316	A 582 B 345 C 570

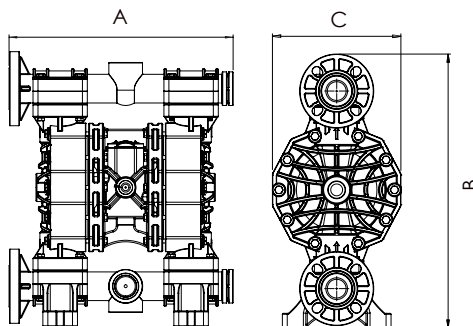

COMPOSITION	
Wetted parts	• PP • PVDF • ALU • AISI 316
Diaphragms	• HYTREL + PTFE • SANTOPRENE + PTFE • HYTREL • SANTOPRENE • EPDM • NBR
Valve Balls	• PTFE • AISI 316 • EPDM • NBR
Valve Seats	• PP • PVDF • ALU • AISI 316 • UPPE
Gaskets	• EPDM • VITON • NBR • PTFE

Connections scheme page 28

* Optional

ASTRA

DDA 200-650

ARGALAIR

آتور صنعت
ATOORSANAT



PVDF	+80°	-10°	41,5 Kg	+ 2,2 Kg	AISI 316	+80°	-10°	54,5 Kg	+ 2,2 Kg	PP	+60°	-5°	34,5 Kg	+ 2,2 Kg	Alu	+80°	-10°	38,5 Kg	+ 2,2 Kg
Pump Packaging				Pump Packaging				Pump Packaging				Pump Packaging							

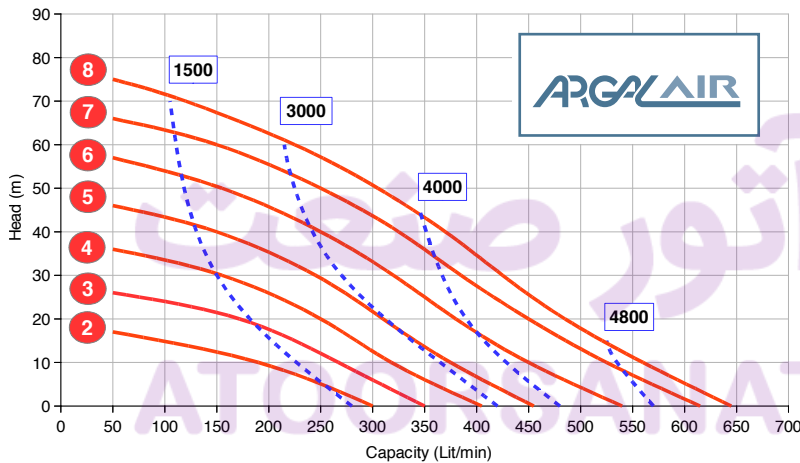

bar Air Pressure main supply NI/min Air consumption

TECHNICAL DATA	
Fluid connections	2" BSP • NPT* • FLANGED* DN50
Air connection	3/4" BSP
Max flow rate	650 l/m'
Max air pressure	8 bar
Max delivery head	80 mca
Max suction lift dry	5 mca
Max suction lift wet	9,8 mca
Max size solids	38,55 mm
Noise level	78 dB(A)
Max viscosity	50.000 cPs

DIMENSIONS (mm)	
PP	A 595 B 345 C 565
PVDF	A 595 B 345 C 565
ALU	A 595 B 345 C 560
AISI 316	A 487 B 345 C 599

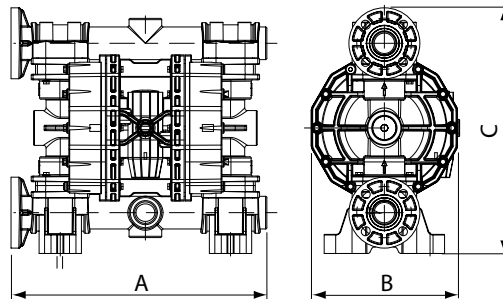

COMPOSITION	
Wetted parts	• PP • PVDF • ALU • AISI 316
Diaphragms	• HYTREL + PTFE • SANTOPRENE + PTFE • HYTREL • SANTOPRENE • EPDM • NBR
Valve Balls	• PTFE • AISI 316 • EPDM • NBR
Valve Seats	• PP • PVDF • ALU • AISI 316 • UPPE
Gaskets	• EPDM • VITON • NBR • PTFE

Connections scheme page 28

* Optional

ASTRA DRUM

Perfect for emptying barrels, drums, cans.



MAIN APPLICATIONS

- AUTOMOTIVE INDUSTRY
- CHEMICAL INDUSTRY
- FOOD INDUSTRY
- WASTE DISPOSAL TECHNOLOGY

PUMPS

- ASTRA COMPACT
- ASTRA

ASTRA GEMINI

Delivery and suction manifolds can be doubled in this configuration so that two products can simultaneously be pumped.



MAIN APPLICATIONS

- FLEXOGRAPHIC INDUSTRY
- PAINTING INDUSTRY
- PAPER PROCESSING
- PRINTING INDUSTRY
- WASTE WATER TECHNOLOGY

PUMPS

- ASTRA

ASTRA FREE

The fluid is carried by compressed air while an electric signal controls the speed. In this way, metering, measurement and other applications of the electric command can be majorly accurate. Versions "ASTRA FREE". It can be interconnected with a large range of devices to completely automatise the operation.

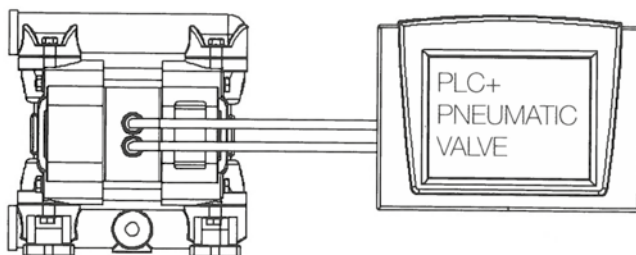
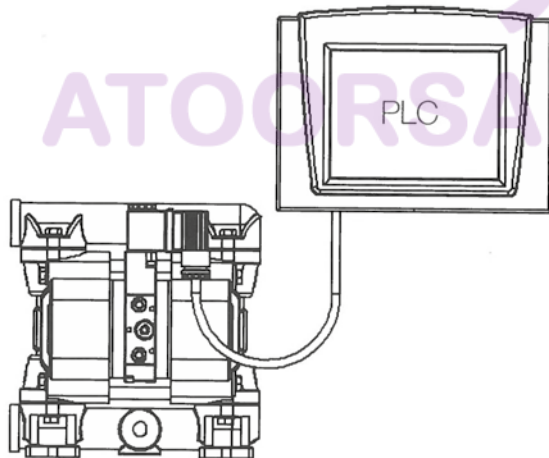

MAIN APPLICATIONS

- CHEMICAL INDUSTRY
- FLEXOGRAPHIC INDUSTRY
- PAINTING INDUSTRY
- PRINTING INDUSTRY
- WASTE WATER TECHNOLOGY

PUMPS

- ASTRA COMPACT
- ASTRA

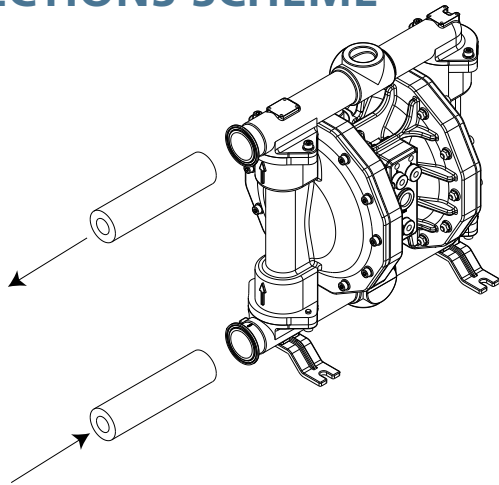

STANDARD CONNECTIONS 2 O

Maximise the pump flow rate

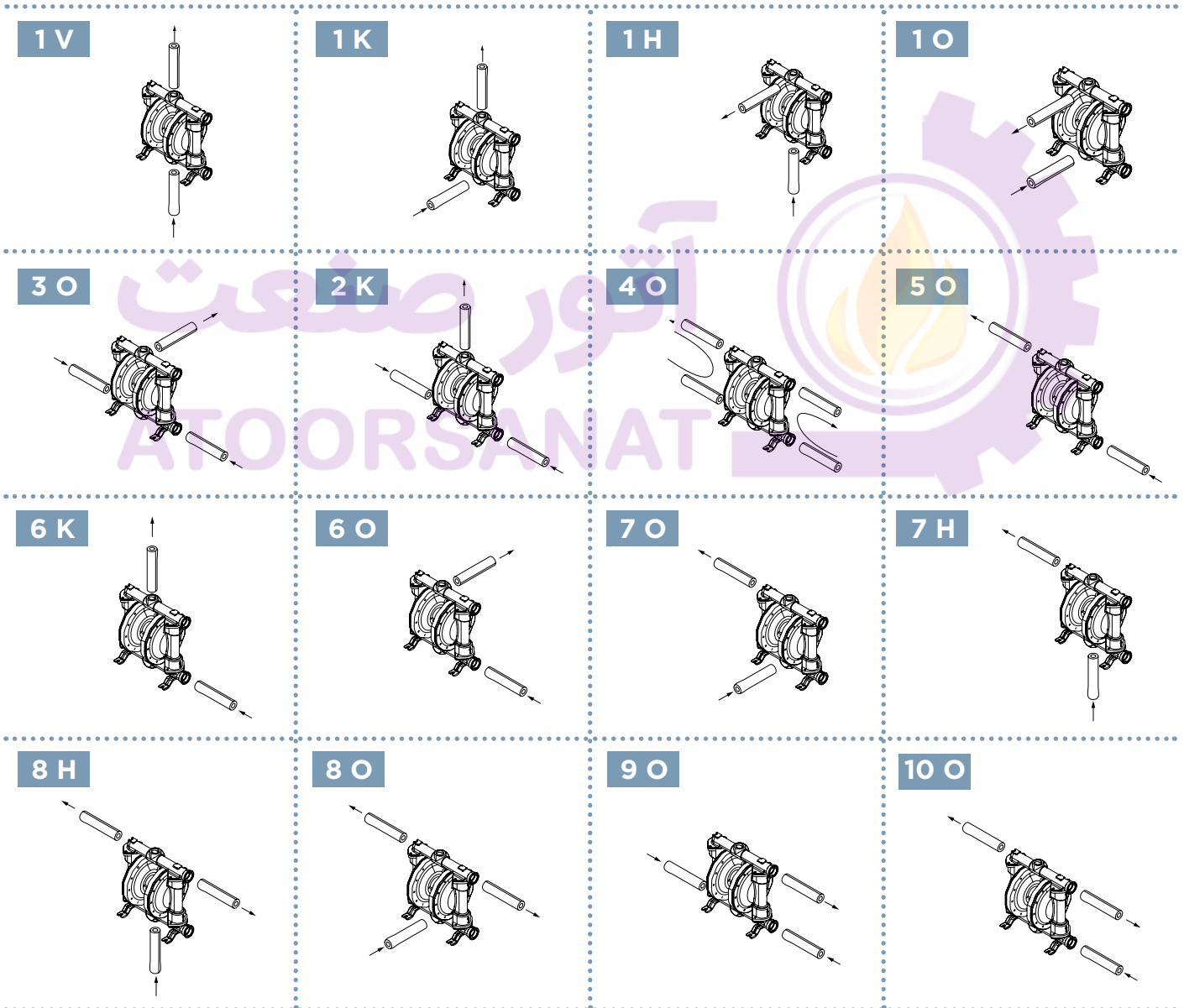

ASTRA FOOD

ASTRAFOOD range can be used for handling and pumping products from food industry and related ones. These pumps comply with **FDA recommendations**, with the parts in contact all the fluid made of **AISI 316 electro-polished** with **125 Ra** finish and PTFE, both certified for food usage.

FDA
COMPLIANT



FOOD INDUSTRY		COSMETIC PHARMACEUTICAL INDUSTRY		VARIOUS INDUSTRY	
Product	cP	Product	cP	Product	cP
Butter	50.000	Yoothpaste	5.000	Oil SAE70	18.000
Whipped acid cream	13.000	Gel	2.000	Paper pulp in water	15.000
Mayonnaise	6.000	Glycerine	1.400	Barbotine	2.000
Honey	1.500÷3.000	Shampoo	250	Grease lubr.	2.000
Marmalade	<1.000			Mineral oil	800
Tomato sauce	180			Oil SAE30	350
Yogurt	100			Varnish	300
Olive oil	100	PRODUCTS VISCOSITY			

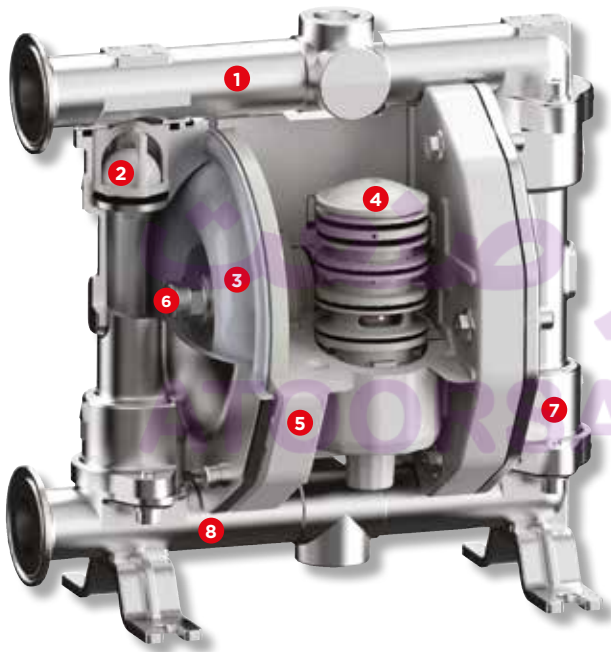

- 1 Delivery manifold
- 2 Ball valve
- 3 Diaphragm
- 4 Air Distributor
- 5 Central casing
- 6 Wetted washer
- 7 Pump casing
- 8 Suction manifold

to FDA regulation, wet parts of electro polished SUS 316 with surface finish to **125 Ra** (average **2,7 µm**) and PTFE, both certified for food applications.

All **ASTRAFOOD** pumps comply to ATEX, Zona 2, regulation and are adequate to operate in areas with atmosphere potentially explosive and, with the variant of the conductive executions, can operate also in areas classified as ATEX Zone 1.

These pumps are capable to pump fluids with very high viscosity and temperature up to **95°C**.

All other constructive and functional characteristics are equal to those of the ASTRA.

ASTRAFOOD "DFA" serie thanks to their characteristics and design can be applied for the transfer of fluids deployed in industries as food, the cosmetics, pharmaceuticals, or chemical additives, beverages, dairy, biotechnologies, medical appliances, paint and in all those applications were a quick release clamp connection is required or appreciated.

These pumps are usually used to transfer or to remove the products from the mixing contains or storage basins or to pack them in bottles or similar containers.

The air operated double diaphragm pumps **ASTRAFOOD** are constructed with materials compliant



DFA 125 - 250



DFA 38-18

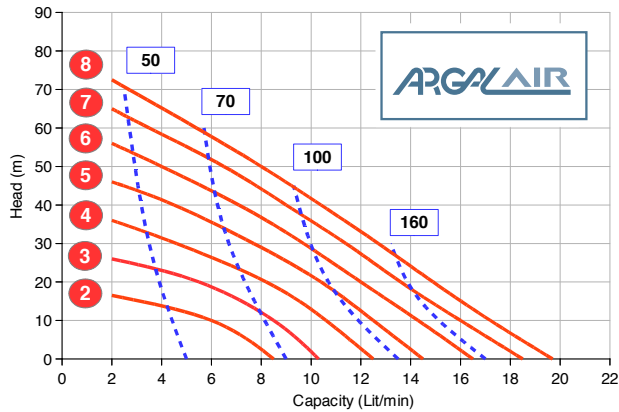

bar Air Pressure main supply **NI/min** Air consumption

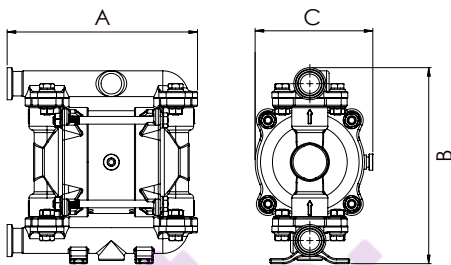

COMPOSITION (mm)	
AISI 316	A 148 B 92 C 153

TECHNICAL DATA

Fluid connections	• Tri-Clamp 1/2" • BSP • NPT
Air connection	6 mm
Max flow rate	18 l/m
Max air pressure	8 bar
Max viscosity	12.000 cPs

COMPOSITION

Wetted parts	• AISI 316 Polished
Diaphragms	• NBR+PTFE
Valve Balls	• PTFE • AISI 316
Valve Seats	• AISI 316
Gaskets	• PTFE

Connections scheme page 28

DFA 50-30

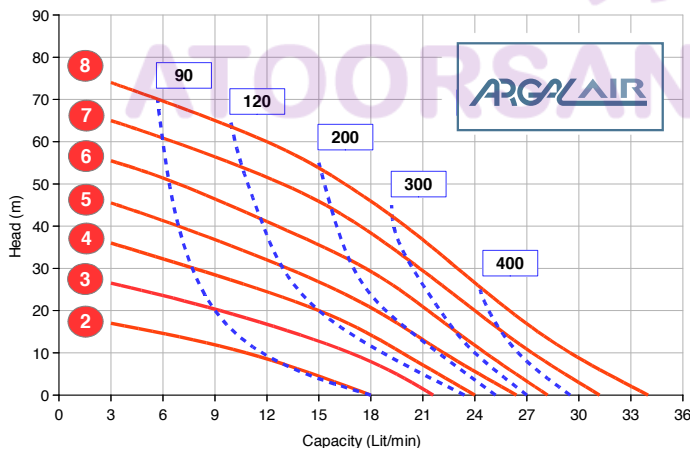

bar Air Pressure main supply **NI/min** Air consumption

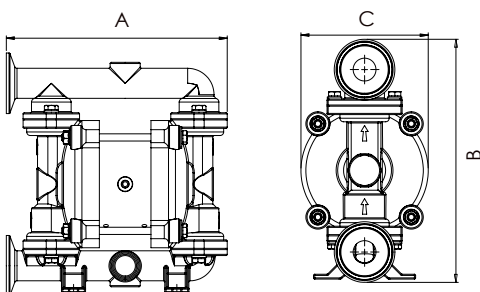

COMPOSITION (mm)	
AISI 316	A 184 B 106 C 203

TECHNICAL DATA

Fluid connections	• Tri-Clamp 1" • BSP • NPT
Air connection	6 mm
Max flow rate	30 l/m'
Max air pressure	8 bar
Max viscosity	15.000 cPs

COMPOSITION

Wetted parts	• AISI 316 Polished
Diaphragms	• HYTREL+PTFE
Valve Balls	• PTFE • AISI 316
Valve Seats	• AISI 316
Gaskets	• PTFE

Connections scheme page 28

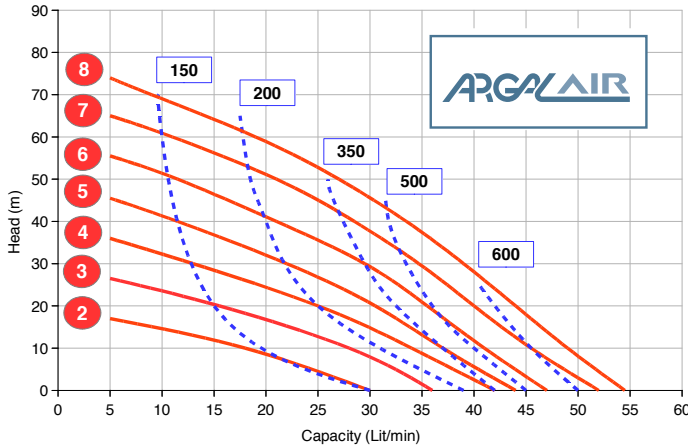

bar Air Pressure main supply **NI/min** Air consumption

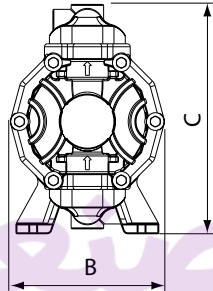
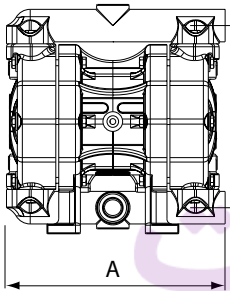

DIMENSIONS (mm)

AISI 316 **A 251 B 249 C 177**

TECHNICAL DATA	
Fluid connections	• Tri-Clamp 1" • BSP • NPT
Air connection	¼" BSP
Max flow rate	50 l/m'
Max air pressure	8 bar
Max viscosity	20.000 cPs

COMPOSITION	
Wetted parts	• AISI 316 Polished
Diaphragms	• HYTREL+PTFE
Valve Balls	• PTFE • AISI 316
Valve Seats	• AISI 316
Gaskets	• PTFE

Connections scheme page 28





DFA 75-100

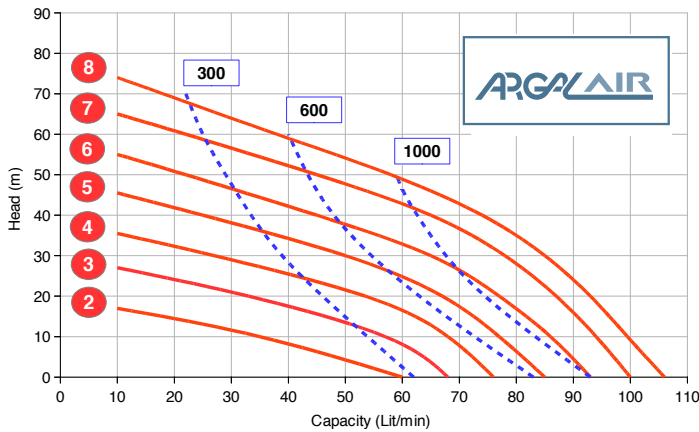

bar Air Pressure main supply **NI/min** Air consumption

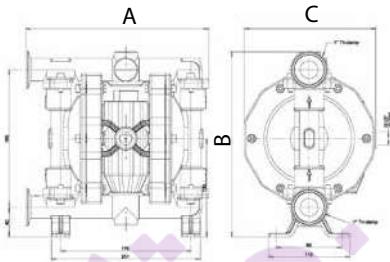

DIMENSIONS (mm)	
AISI 316	A 247 B 249 C 177

TECHNICAL DATA	
Fluid connections	• Tri-Clamp 1" • BSP*
Air connection	3/8" BSP
Max flow rate	100 l/m'
Max air pressure	8 bar
Max viscosity	25.000 cPs

COMPOSITION	
Wetted parts	• AISI 316 Polished
Diaphragms	• HYTREL+PTFE
Valve Balls	• PTFE • AISI 316
Valve Seats	• AISI 316
Gaskets	• PTFE

Connections scheme page 28

* Optional

DFA 125-250

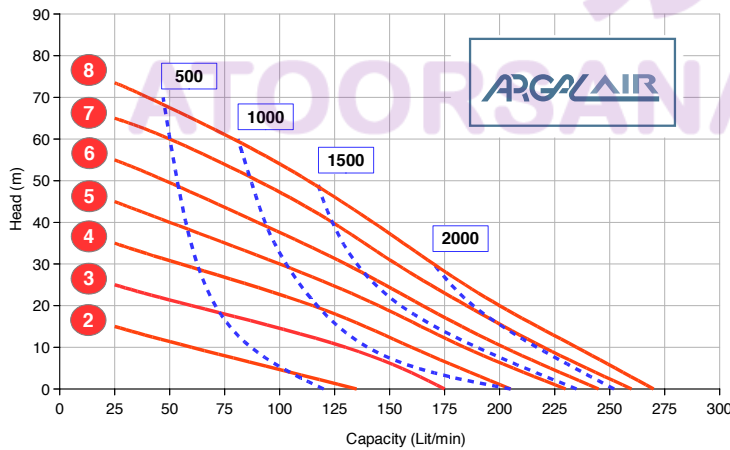

bar Air Pressure main supply **NI/min** Air consumption

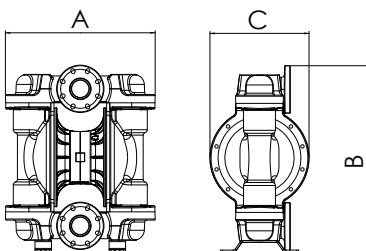

DIMENSIONS (mm)	
AISI 316	A 360 B 222 C 346

TECHNICAL DATA	
Fluid connections	• Tri-Clamp 1 1/2" • BSP*
Air connection	1/2" BSP
Max flow rate	250 l/m'
Max air pressure	8 bar
Max viscosity	35.000 cPs

COMPOSITION	
Wetted parts	• AISI 316 Polished
Diaphragms	• HYTREL+PTFE
Valve Balls	• PTFE • AISI 316
Valve Seats	• AISI 316
Gaskets	• PTFE

Connections scheme page 28

* Optional

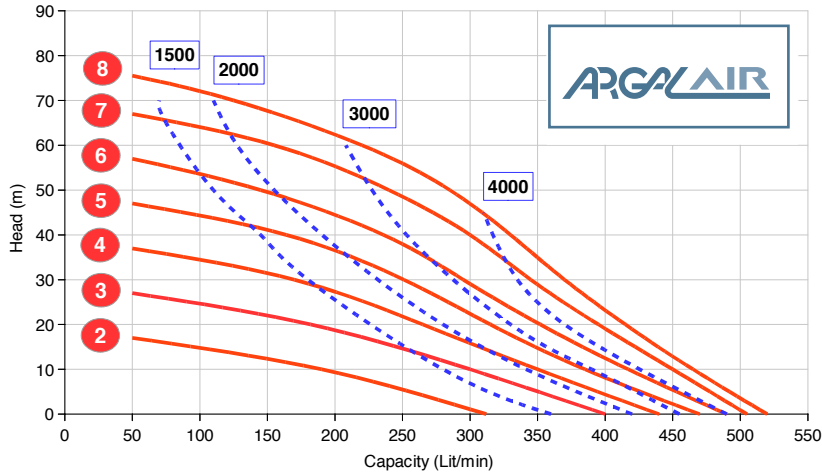

bar Air Pressure main supply **NI/min** Air consumption

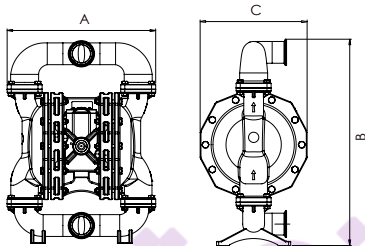

DIMENSIONS (mm)	
AISI 316	A 361 B 260 C 502

TECHNICAL DATA	
Fluid connections	• Tri-Clamp 2½"
Air connection	¾" BSP
Max flow rate	500 l/m'
Max air pressure	8 bar
Max viscosity	50.000 cPs

COMPOSITION	
Wetted parts	• AISI 316 Polished
Diaphragms	• NBR+PTFE
Valve Balls	• PTFE • AISI 316
Valve Seats	• AISI 316
Gaskets	• PTFE

Connections scheme page 28

* Optional

DFA 200-650

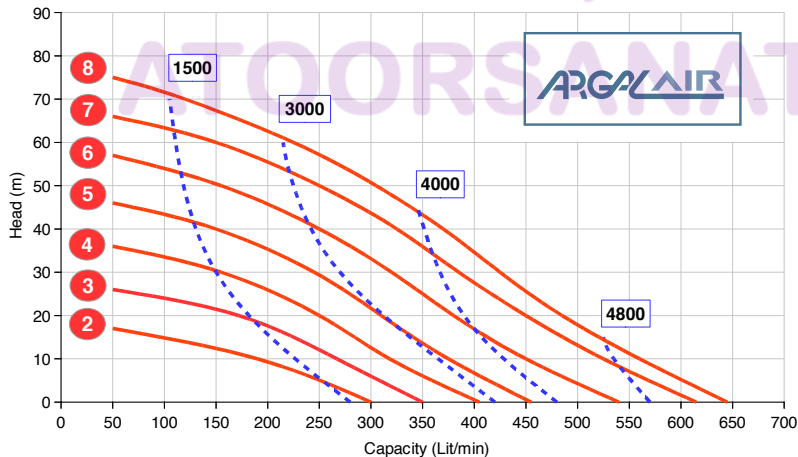

bar Air Pressure main supply **NI/min** Air consumption

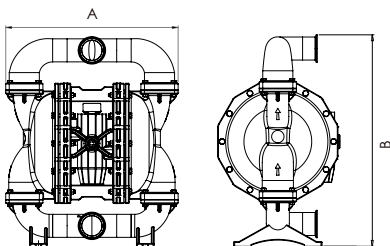

DIMENSIONS (mm)	
AISI 316	A 487 B 598

TECHNICAL DATA	
Fluid connections	• Tri-Clamp 2½" • BSP*
Air connection	¾" BSP
Max flow rate	650 l/m'
Max air pressure	8 bar
Max viscosity	50.000 cPs

COMPOSITION	
Wetted parts	• AISI 316 Polished
Diaphragms	• HYTREL+PTFE
Valve Balls	• PTFE • AISI 316
Valve Seats	• AISI 316
Gaskets	• PTFE

Connections scheme page 28

* Optional

MISTRAL AODD PUMPS

WITH AISI 316L CENTER BLOCK

AODD MISTRAL



Zone 1

MISTRAL range represents the safest and most efficient solution for heavy dangerous and even explosive applications but also for process applications. The entire construction of the body pumps and of the distributor is realised in AISI 316L (low carbon content) making the pumps extremely resistant to corrosion, robust and perfect for continuous 24/24 operation.



MAIN APPLICATIONS

- Off-Shore platforms
- Marine
- Chemical process
- Cleaning/Cement mixer sewage
- Mining



The significant advantages of the distribution system designed for the **MISTRAL**:

- **simple and maintenance free 5-component construction,**
- material of construction resistant to wear and chemicals for long lasting trouble free lifetime,
- affordable cost,
- High-shift speed and high-discharge speed of the exhaust air,
- low consumption as consequence of the fine tuned air quantity supplied to the diaphragms.

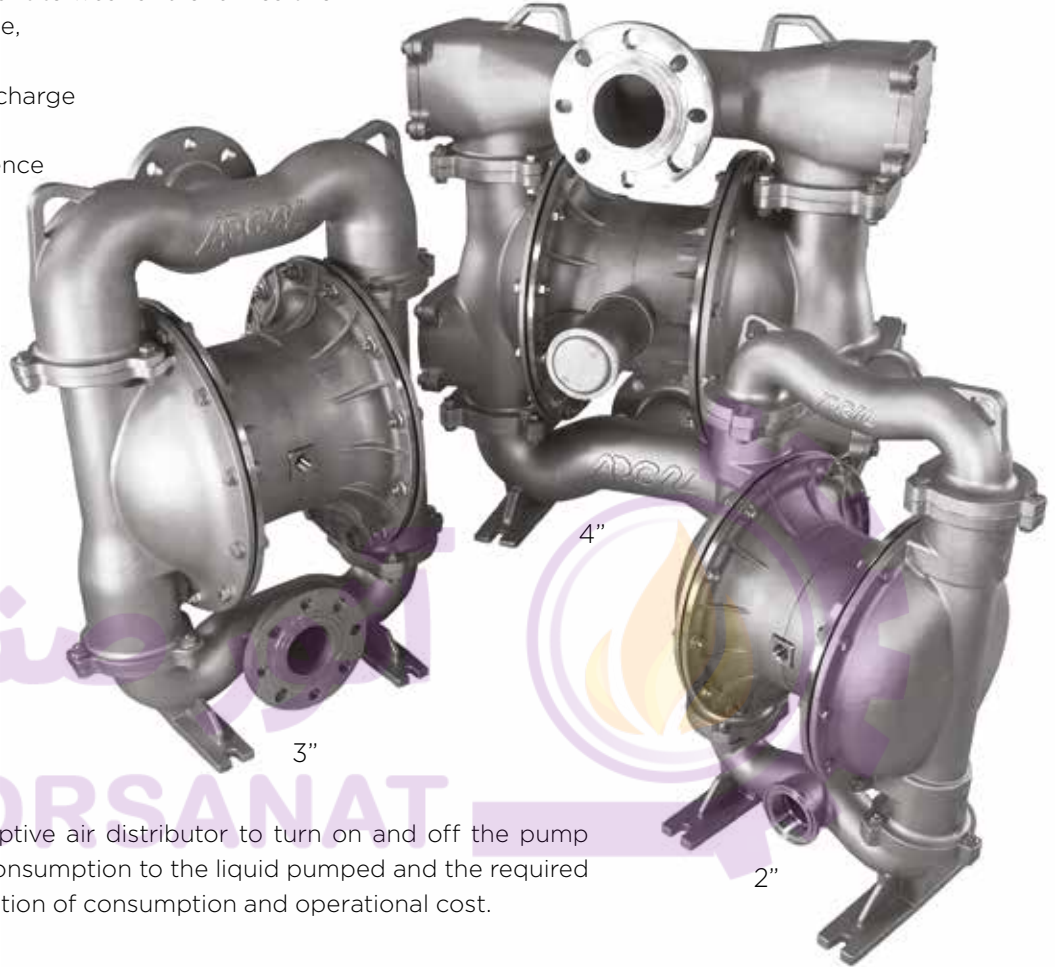

“PROGRESS” VALVE

Argal designed a special adaptive air distributor to turn on and off the pump and to fine tune the air flow consumption to the liquid pumped and the required performance with a real reduction of consumption and operational cost.

BR

AISI 316 L

Alu

DX



(PTFE diaphragms)



(NBR, EPDM, SANTOPRENE diaphragms)



The materials used, the switching speed and the distribution spool shift speed all highly **resist to the formation of ice** that detaches itself from the surface to get then ejected from the discharge tube. Possible remaining will never affect the pump operation.



MISTRAL

200 (2") - 300 (3") - 400 (4")

ARGALAIR

آتور صنعت
ATOORSANAT

TECHNICAL DATA	200 (2")	300 (3")	400 (4")
Maximum Capacity Litres/Minute	680	1100	1280
Materials of Pump Housings & Center Block	AISI 316L	AISI 316L	AISI 316L
Fluid Port (ISO-ANSI Flange) Intake & Discharge Connections	2" DN50	3" DN80	4" DN100
Air Inlet	1/2" female NPT	3/4" female NPT	3/4" female NPT
Air Exhaust (included silencer)	3/4" female NPT	1" female NPT	1" female NPT
Maximum Working Pressure	7 bar	7 bar	7 bar
Maximum Cycles per Minutes	140	96	96
Max. Discharge Volume/Cycles	3,7 litres	8,5 litres	8,5 litres
Maximum Solids Particle Size	9 mm	11 mm	13 mm
Suction Lift (dry)	6 m	6 m	4,5 m

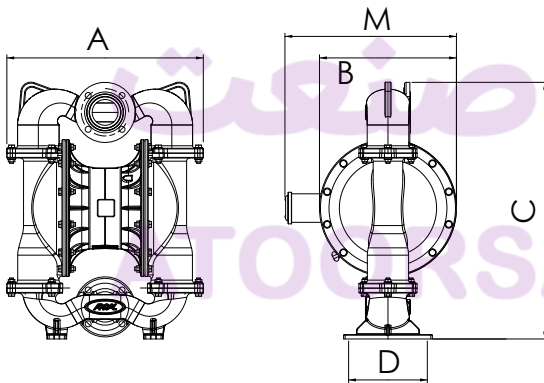

DIMENSIONS	200 (2")	300 (3")
A	440	624
B	340	435
C	707	815
D	220	250
M	460	570

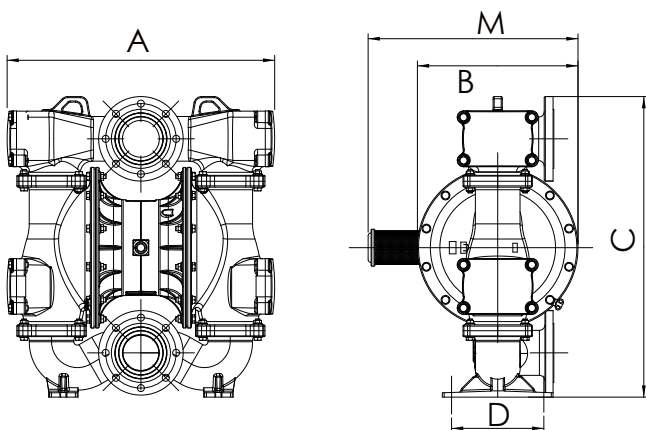

DIMENSIONS	400 (4")
A	725
B	435
C	815
D	235
M	570

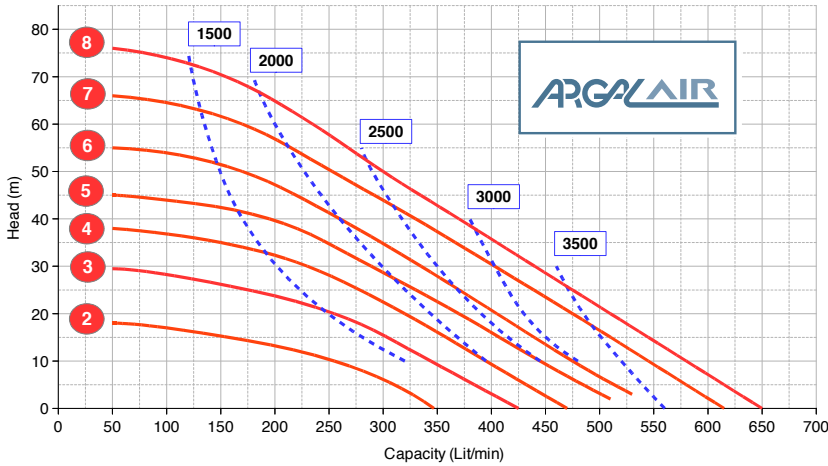

COMPOSITION MISTRAL 2"	
Wetted parts	• AISI 316L • DUPLEX • BRONZE
Diaphragms	• EPDM • NBR • HYTREL • SANTOPRENE • HYTREL +PTFE
Valve Balls	• EPDM • NBR • PTFE • AISI 316L
Valve Seats	• POLIURETANO • UPPE • PVDF • AISI 316L
Gaskets	• EPDM • NBR • FKM • FEP

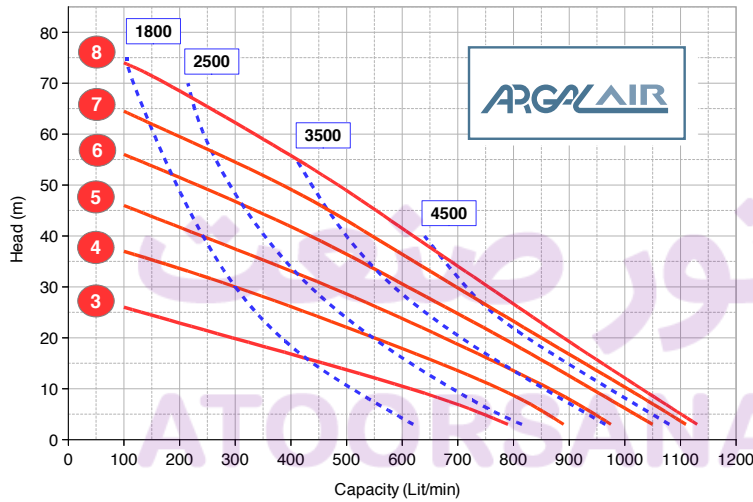

COMPOSITION MISTRAL 3"	
Wetted parts	• AISI 316L • DUPLEX • BRONZE
Diaphragms	• EPDM • NBR • EPDM+PTFE • NBR+PTFE
Valve Balls	• EPDM • NBR • PTFE • AISI 316L
Valve Seats	• POLIURETANO • UPPE • PVDF • AISI 316L
Gaskets	• EPDM • NBR • FKM • FEP

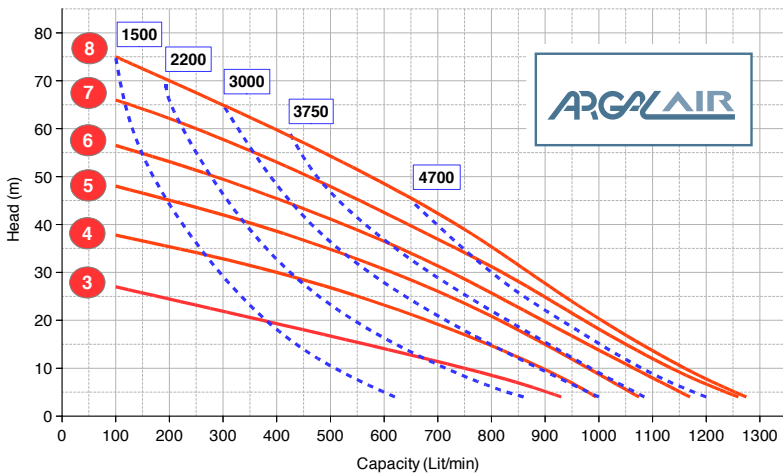

COMPOSITION MISTRAL 4"	
Wetted parts	• AISI 316L • DUPLEX • BRONZE
Diaphragms	• EPDM • NBR • EPDM+PTFE • NBR+PTFE
Valve Balls	• EPDM • NBR • PTFE • AISI 316L
Valve Seats	• POLIURETANO • UPPE • PVDF • AISI 316L
Gaskets	• EPDM • NBR • FKM • FEP

bar Air Pressure main supply NI/min Air consumption

AIRSATURN

"COMPOSITE MATERIALS
PNEUMATIC PUMPS".



Zone 2

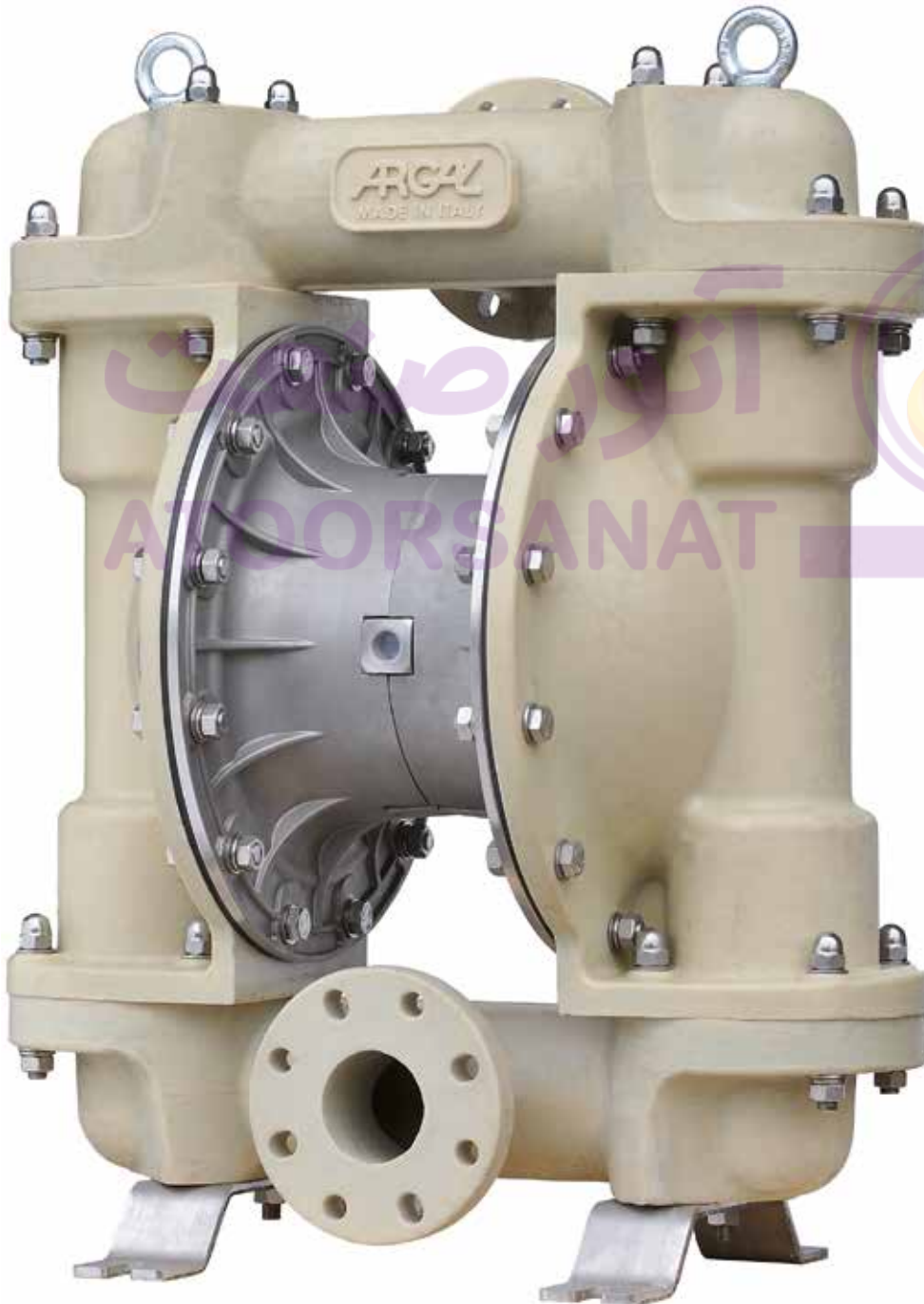

FRP

WORLD FIRST

Thanks to the experience of the pneumatic pumps ASTRA from size 1/4" to 2" and the know how acquired manufacturing the Fiberglass centrifugal pumps SATURN under his belt, Argal could design and propose first to market these new air pumps made of thermoset resins. The main functional characteristics and peculiarities of the air pumps and its main applications are widespread and generally known.

So far the market lacked a solid and effective proposal for pneumatic pumps of large sizes made of non-metallic materials.

Some competitors offer 3" pumps made of plastic with **the physical-and mechanical limits intrinsic to the nature of the thermoplastic resins** and to overcome these limitations resort to **metal alloys with in turn have limits themselves** (one overall the high cost but even the corrosion-abrasion resistance).

"The composite MADE ARGAL PUMPS, not suffering the limits mentioned above, are proposed as the solution of synthesis and/or alternative".

MAXIMUM CHEMICAL AND MECHANICAL RESISTANCE.

Are obtained deploying composite materials made of vinyl ester resins reinforced with long strand only glass fibres moulded with RTM technique in its factory located in Brescia.

Pumps and parts wet by the liquid pumped in particular have important prerogatives:

- high chemical resistance (the highest among resins, polyester);
- mechanical resistance comparable to some metal alloys;
- dimensional stability, characteristic of the thermosetting resins which during catalysis transform themselves irreversibly becoming insoluble and infusible;
- abrasion resistance and resistance to aging;
- resistance to low and high temperatures (from -35°C to + 115°C);
- lightness typical of composites which, because of differentiated modulus of elasticity for the various parts of the pump and with the minimum thickness of 20 mm exceed the hydrostatic tests from 20 to 50 bar;
- resistance to flame propagation in case of fire.



MATERIALS PROFILE Pump Casings

Pump casings of **AIRSATURN** are of the following types of FRP:

V1G standard vinyl ester resin for **general use**;
V1A mixture of vinyl ester resin for **abrasive liquids**;

V1C mixture of vinyl ester resin for **liquids with chlorine**;
V1F mixture of vinyl ester resin for **liquids with fluorine**.

AIRSATURN

300 (3") - 400 (4")

ARGAL AIR

آتور صنعت
ATOORSANAT



The significant advantages of the distribution system designed for the AIRSATURN:

- **simple and maintenance free 5-component construction,**
- material of construction resistant to wear and chemicals for long lasting trouble free lifetime,
- affordable cost,
- High-shift speed and high-discharge speed of the exhaust air,
- low consumption as consequence of the fine tuned air quantity supplied to the diaphragms.



"PROGRESS" VALVE

Argal designed a special adaptive air distributor to turn on and off the pump and to fine tune the air flow consumption to the liquid pumped and the required performance with a real reduction of consumption and operational cost.

FRP



(PTFE diaphragms)



(NBR, EPDM, SANTOPRENE diaphragms)



The materials used, the switching speed and the distribution spool shift speed all highly **resist to the formation of ice** that detaches itself from the surface to get then ejected from the discharge tube. Possible remaining will never affect the pump operation.



AIRSATURN

300 (3") - 400 (4")

TECHNICAL DATA	300 (3")	400 (4")
Maximum Capacity Litres/Minute	1100	1280
Materials of Pump Housings & Center Block	FRP + AISI 316L	FRP + AISI 316L
Fluid Port (ISO-ANSI Flange) Intake & Discharge Connections	3" DN80	4" DN100
Air Inlet	3/4" F NPT	3/4" F NPT
Air Exhaust (included silencer)	1" F NPT	1" F NPT
Maximum Working Pressure	7 bar	7 bar
Maximum Cycles per Minutes	96	96
Max. Discharge Volume/Cycles	8,5 litri	8,5 litri
Maximum Solids Particle Size	11 mm	13 mm
Suction Lift (dry)	6 m	4,5 m

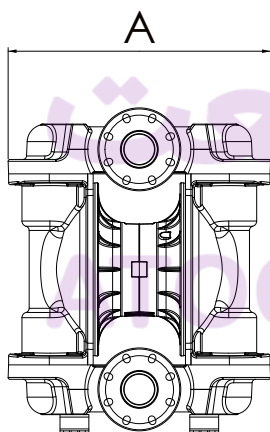

DIMENSIONI (mm)	300 (3")	400 (4")
A	662	728
B	436	482
C	803	904

Connections scheme 1 C - 1 O page 28

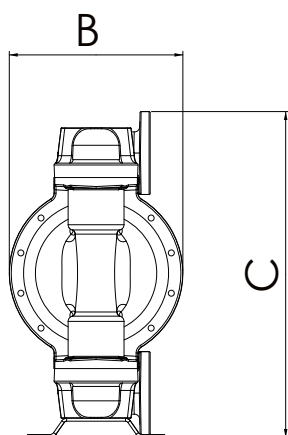

TEMPERATURE	
MATERIALI MEMBRANE	TEMP. °C MIN/MAX
EPDM	+100 -35
NBR	+80 -20
EPDM + PTFE	+120 -35
NBR + PTFE	+80 -20

AIRPISTON

The AIRPISTON piston pumps family addresses the problems inherent to metering products with high viscosity up to 1,000,000 cPs.

These pumps are **made combining synthetic materials for the body with stainless steel AISI 316** for most of the wet parts.

AIRPISTON range, complies with **the requirement of ATEX** Class 3: Zone 2 (Serie II 3/3GD IIB T 275°F). AIRPISTON pumps are offered in inline or submerged version:

- **In-line pumps**, meant for "pass through" installation with suction pipe and delivery pipe connected to the system.
- **Submerged pumps**, with casing submerged in the liquid and delivery pipe connected to the system.

MAIN

APPLICATIONS

- **Mechanics:** Lubricants and lubro-refrigerants
- **Energy:** Gas odorization
- **Ecology:** Coagulant, flocculent, deodorization
- **Surface Treatment:** Colorant liquids, varnish
- **Cosmetics:** Essences, pastes, lotions, soaps, shampoos
- **Textile:** Basic resins preparation and mix of additive.



Both versions share the pneumatic motor which is the most sophisticated and important part of the device and is responsible for:

- **Actuating the piston to the required stroke length;** adjustable by ergonomic handle command from 0 to 100%
- **controlling the piston speed** movement as well as the frequency drive **from a minimum of 3 pumping per minute to 100 pumping per minute;**
- regulating one of the two lengths without affecting the other (frequency/cycles);
- **accepting external inputs** to execute single stroke metering or **batch dosing;**
- generating outputs to **command external devices** for a total dosing control.

Motor is provided with control connexion.

Addition of add external pneumatic devices (e.s. pilot-operated valve), does not require additional piping.

APL IN-LINE PUMPS - HIGH VISCOSITY

APL pumps operate with viscosity up to **1,000,000 cPs**.

The volume of liquid delivered by each single pump stroke and its **frequency per minute** are controlled.

The pump **generates a signal** at the end of the **metering cycle** as integrated characteristic.

The frequency is controlled by **pneumatically operated unstable oscillator** or external pneumatic or electric devices (**remote control**).

ATOORSANAT

APS SUBMERGED PUMPS - VERY HIGH VISCOSITY

This version is deployed to pump liquids of high-level of viscosity.

The casing is immersed in the fluid to minimise risks of cavitation and consequent erosion and premature wear of parts which is the main cause of failure of pumps to address this service

The neat design of APS pumps simplifies installation for integrates:

- Suction valve integrated within the casing.
- Delivery valve integrated within the pumping piston.
- Sealed pumping piston.
- 2 spheres within its valves.

The motor actuates the piston assy by mean of a metallic stem hosted within the dual purpose metallic (or synthetic) tube.

The liquid pumped by the piston assy pass through the dual purpose pipe and is delivered from its hydraulic connection.

The length of the dual purpose tube can be customised to match as much as possible the required dive depth.



APL



APS



ACL

IN-LINE OR SUBMERGED METERING BASE PUMPS (ABL - ABS - ACL) ARE PERFECT FOR METERING HIGH AND VERY HIGH-LEVEL OF VISCOSITY.

The volume regulator control is integrated while the metering command is provided by an external unit.

The ABL and the ABS are realised in two different typologies: “In-line” (ABL) or “Submerged” (ABS)

ACL- The ACL realised “in-line” are ideal for metering high-viscosity fluids (<3000 cPs). Control devices can be assembled on to the ACL pump on pre set positions thanks to its parallelepiped shape. Liquid connections can be oriented in many positions.

All the BASE pumps models are in fact metering pumps that can regulate the dosed fluid volume. Though, they are not equipped with an autonomous control as the metering command is provided by an external unit (on ACL model, a working frequency control can be added for example). Pumps can be deployed in batteries (of 2 or more units) and a be run simultaneously with single command.



ABS



CDS

COMMAND DEVICES

- “Main” APS or APL piston metering pumps
- Frequency generator with pneumatic output
- Transducer with pneumatic output operated by the system cycle (where the pump is installed).

In **CDS system**, pumps have a flow rate equal or inferior to the main pump’s one.

CDS COMBINED METERING SYSTEM

Smartly combines one main metering pump with one minor metering pump to deliver a single modular device to precisely mix two products of different physical characteristics. It is a standard feature of main pump models APL and APS 2.

SPECIFIC APPLICATIONS:

MECHANICS:

Lubro-refrigerants metering
Automatic refill with lubro-refrigerants

ECOLOGY AND ENVIRONMENT:

Dilution and dosage of flocculent liquids, dilution and metering of deodorizers.

Requires the addition of static auto-lube system **SMX** if the products have various viscosity.

SMX STATIC BLENDER

This device is built in 2 lengths and is used for blending two products with different physical characteristics to obtain one homogeneous compound.

The cylindrical construction made with synthetic materials encases the calibrated internal casing of the blending element.

The two outputs are equipped with non return valves.

ACCESSORIES SHARED BY ALL AIRPISTON

AIRPISTON pumps share a list of accessories to match different scenarios and satisfy different requirements:

- External timer (to set time lapse between metering cycles from 0 to many minutes).
- Cycle counter (pre-settable).
- Cycle counter (to actuate dosing batch).
- Solenoid valve (for remote electric command).
- Transducer (to convert the "end of cycle" signal from pneumatic to electric).
- Static blender (to instantly meter and blend meter products).
- Combined metering system kit consisting of: APL pump support, SMX static blender, water main supply adaptor, ABS pumps connexions.

PISTON METERING PUMPS

AIRPISTON

ARGALAIR



AIRPISTON METERING PUMPS MAIN CHARACTERISTICS

MODEL	FLOW RATE l/h min-max	MAX volume per cycle in CC	MAX frequency (cycle per min')	MAX delivery pressure (bar)
ABL/ABS/ACL 1	0,003 - 1	0,18	100	30
ABL/ABS /ACL 4,5	0,013 - 4,5	0,75	100	30
ABL/ABS/ACL 12 APL/APS 12	0,036 - 12	2	100	30
ABL/ABS 27 APL/APS 27	0,08 - 27	4,5	100	30
ABL/ABS 54 APL/APS 54	0,16 - 54	9	100	30
ABL/ABS 75 APL/APS 75	0,22 - 75	12,5	100	30
ABL/ABS 120 APL/APS 120	0,36 - 120	20	100	30
APL/APS 160	0,80 - 160	45	60	16
APL/APS 320	1,60 - 320	90	60	16
APL/APS 450	2,20 - 450	125	60	16

ADJUSTABLE CYCLE VOLUME: from 10 to 100%
ADJUSTABLE FREQUENCY: from 3 to 60/100 CYCLE per MIN'
INLET PRESSURE: from 2 to 8 BAR

MATERIALS: MAIN CONFIGURATIONS (Custom layouts available on request).

VERSION	CASING	PUMPING PISTON	GASKET	DRUM/STEM
DL S N DL S D	POMc	AISI 316	NBR EPDM	AISI 316
WW U D WW U T	PP	CER	EPDM PTFE	PP/AISI 316
DF C V DF C T	PVDF	CER	FPM PTFE	PVDF/AISI 316
AL S V AL S T	ALU	AISI 316	FPM PTFE	AISI 316
SS S D SS S T	AISI 316	AISI 316	EPDM PTFE	AISI 316

AIRDRAIN series was designed to operate in wells. The main applications are reclaimed areas drainage, ground level control, supernatant and percolate from municipal solid waste collecting areas.

AIRDRAIN is composed of 4 models with different operating system:

- **BSD** BASIC STATIC DRAIN
- **ASD** AUTOMATIC STATIC DRAIN
- **ADD** AUTOMATIC DIAPHRAGM DRAIN
- **ABD** AUTOMATIC BELLOW DRAIN

BSD - BASIC STATIC DRAIN is the most reliable pump of AIRDRAIN series. The pump casing consisting of a hollow vessel is fitted with one intake and one evacuation liquid valve. An airline connects the pump casing with the pneumatic operating control unit located at the top of the well. Once submerged, the pump casing is flooded till filled up through the intake valve because of the liquid's hydrostatic pressure and the air contained inside is displaced through the airline connected to the control unit.

ASD - AUTOMATIC STATIC DRAIN is similar in operating principle to BSD pumps. ADS differ from BSD pumps for a n BSD pumps do not require the external pneumatic operating control unit. The replenishment and the evacuation phases of the BSD pumps are controlled by its internal air compressor control device assisted by a floating probe to detect the liquid level. ADS pumps evacuate exhausted air through a dedicated pipe. ADS pumps do not need the bathymetric probe to monitor the level of the liquid pumped for the function is delivered by the mentioned floating probe. BSD and ASD pump comply with the requirement of ATEX Class 3.

ADD - AUTOMATIC DIAPHRAGM DRAIN These automatic pumps do not require external controls. ADD model delivers the pumping effect by a flexible diaphragm coupled to suction and delivery valves. It can be supplied with liquid level detection to stop once the liquid is missing. The pump does not fail if run dry. This design is advantageous for the pump that can operate properly till the liquid is completely run out even if the pump is not entirely submerged. As an additional bonus, these pumps are extremely short which reduces the risk for the pump to be abandoned inside the well if it deforms.

ABD - AUTOMATIC BELLOW DRAIN is similar to ADD with the difference that the element responsible for delivering the liquid flow is not a flexible diaphragm but a bellow. Thanks to the reduced diameter of the bellow and the diameter of the diaphragm, the ABD pumps are compacter than ADD pumps hence easier to install into minor-size wells.



ADD and ABD pumps are special for they comply with the requirement of ATEX Class 2: zone 1, as such pumps can be safely operated into wells and ideal for extracting percolate from municipal solid waste collecting areas with biogas presence and consequent risk of explosion.

Options for all AIRDRAIN Pumps:

- Installation kit for wells (pressure reducer, suspension cable, air compressed and liquid pipes).
- Lamellar filter on the intake.
- Level control probe for liquid collection tanks, with min. max.
- Only for BSD pumps: level control bathymetric probe
- Only for ADD and ABD pumps: level control device

AIRDRAIN PUMPS MAIN CHARACTERISTICS

MODEL	PUMP DIAMETER mm	FLOW RATE l/h min-max	MAX volume per cycle in CC	MAX frequency (cycle per min')	MAX delivery pressure (bar)
BSD / ASD	63	6	0,18	10	8
BSD / ASD	90	20	0,75	10	8
ADD	125	18	2	150	8
ABD	70	10	4,5	100	8
ABD	90	18	9	100	8

MATERIALS: MAIN CONFIGURATIONS

VERSION	CASING	DISCHARGE VALVE	INTAKE VALVE	GASKET	DIAPHRAGM BELLOW
BSD / ASD WW	PP	PP	PP	FPM	-
BSD / ASD SS	AISI 316	PP	PP	FPM	-
ADD WW M	PP	PP	PP	FPM	SANTOPRENE®
ABD 70 SS T	AISI 316	PP	PP	FPM	PTFE
ABD 90 WW D	PP	PP	PP	EPDM	EPDM
ABD 90 SS T	AISI 316	PP	PP	FPM	PTFE

SANTOPRENE® is a registered trademarks of Exxon Mobil.

SELENE (DAMPENER)

The range of SELENE flow pulsation dampeners exploits a new technology which minimises the pulsation typical of the flow delivered by air operated double diaphragm pumps. All volumetric pumps as metering pumps with double diaphragm or plumber piston generate pulsations from their pumping alternative motion and hydraulic shocks potentially capable to damage the complete device.

The pulsation dampeners Selene are mounted on the line where the liquid is delivered and reduce drastically pulsation, liquid hammers and vibration of the pump.

The dampener needs its source of pressurised air supply.

Its use is advised when the hydraulic circuit the pump suffers peaks of pressure, thermal expansions, sudden starts add stops or fast valve shut offs of delivery valves.





SELENE dampeners are “active” and do not need tuning or pre loading for they are self adaptive; they can dampen the amplitude of the pulsations up to 90% of their max. amplitude.

Dampeners require a minimal maintenance and are available in the same construction materials of the liquid chambers and diaphragms for thermoplastic pumps and in stainless steel SUS 316 for the metallic versions. For aluminium made pumps the SELENE dampeners are constructed in PPS (Ryton®).

SELENE dampeners are available in ATEX compliant version and are adequate to operate in areas at risk of explosion areas classified as Atex Zone 1.



The major advantages of the Sylene dampener are:

- Stabilizing the flow generated by volumetric pumps
- Reducing significantly the vibrations
- Reducing liquid hammers
- Preventing potentially damaging pressure peaks
- Reducing significantly the noise of the system
- Protecting the appliances connected along the same hydraulic line
- Reducing the maintenance cost of the plant
- Increasing global productivity
- Is operating with liquids viscous or laden with solids.

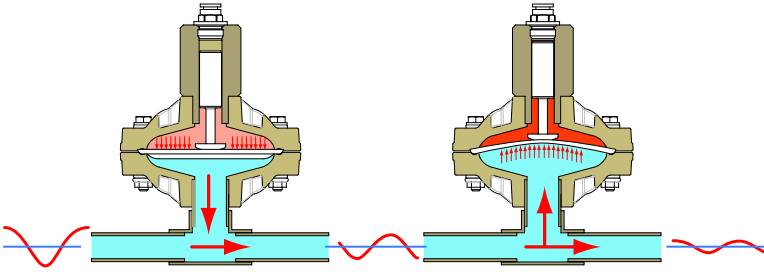

PDA 75 TECHNICAL DATA		MATERIALS	APPLICABILITY
Connections	<ul style="list-style-type: none"> • Threaded BSP • Threaded NPT • Flanged (1) 	<ul style="list-style-type: none"> • PP + Glass fibre • PP + Carbon fibre • PVDF + Carbon fibre • POMC + Carbon fibre • POMC • AISI 316 • AISI 316 Polished 	<ul style="list-style-type: none"> • DDA 25-09 • DDA 38-18 • DDA 50-30 • DDA 50-50
Inlet/Outlet	3/4"		
Air connection	ø 6 mm		
Air exhaust plug	1/4"		
Max pressure	8 bar		
Dimension	ø 120x125 mm		

PDA 100 TECHNICAL DATA		MATERIALS	APPLICABILITY
Connections	<ul style="list-style-type: none"> • Threaded BSP • Threaded NPT • Flanged (1) 	<ul style="list-style-type: none"> • PP + Glass fibre • PP + Carbon fibre • PVDF + Carbon fibre • POMC + Carbon fibre • POMC • AISI 316 • AISI 316 Polished 	<ul style="list-style-type: none"> • DDA 75-100 • DDA 100-100
Inlet/Outlet	1"		
Air connection	ø 8 mm		
Air exhaust plug	1/4"		
Max pressure	8 bar		
Dimension	ø 182x175 mm		

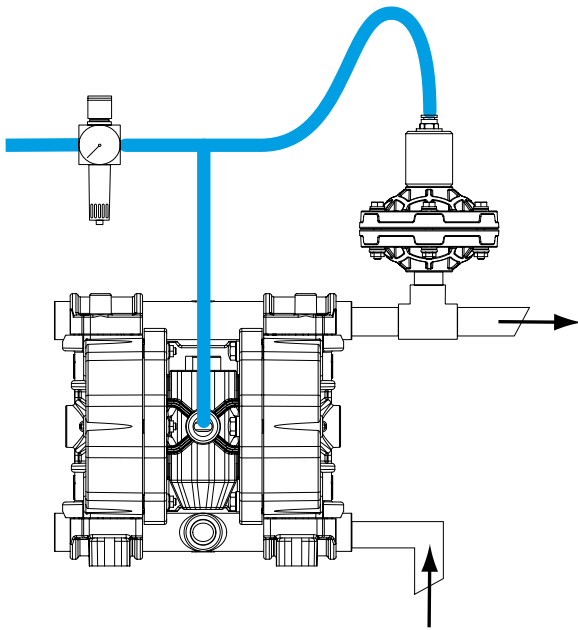

PDA 150 TECHNICAL DATA		MATERIALS	APPLICABILITY
Connections	<ul style="list-style-type: none"> • Threaded BSP • Threaded NPT • Flanged (1) 	<ul style="list-style-type: none"> • PP + Glass fibre • PP + Carbon fibre • PVDF + Carbon fibre • POMC + Carbon fibre • POMC • AISI 316 • AISI 316 Polished 	<ul style="list-style-type: none"> • DDA 100-160 • DDA 125-250
Inlet/Outlet	1 ½"		
Air connection	ø 10 mm		
Air exhaust plug	¼"		
Max pressure	8 bar		
Dimension	ø 231x252 mm		

PDA 200 TECHNICAL DATA		MATERIALS	APPLICABILITY
Connections	<ul style="list-style-type: none"> • Threaded BSP • Threaded NPT • Flanged (1) 	<ul style="list-style-type: none"> • PP + Glass fibre • PP + Carbon fibre • PVDF + Carbon fibre • ALLUMINIUM • AISI 316 • AISI 316 Polished 	<ul style="list-style-type: none"> • DDA 150-500 • DDA 200-650 • MISTRAL 200
Inlet/Outlet	2"		
Air connection	ø 12 mm		
Air exhaust plug	½"		
Max pressure	8 bar		
Dimension	ø 350x405 mm		

CYCLE-COUNTER

Delivers on/off switch signal at any pumping cycle. This signal can be used as an input for a remote cycle counter device; if coupled to the AODD pump, it may constitute a simple and effective dosing system.

COMPATIBILITY

- ASTRA COMPACT
- ASTRA
- MISTRAL
- AIRPISTON

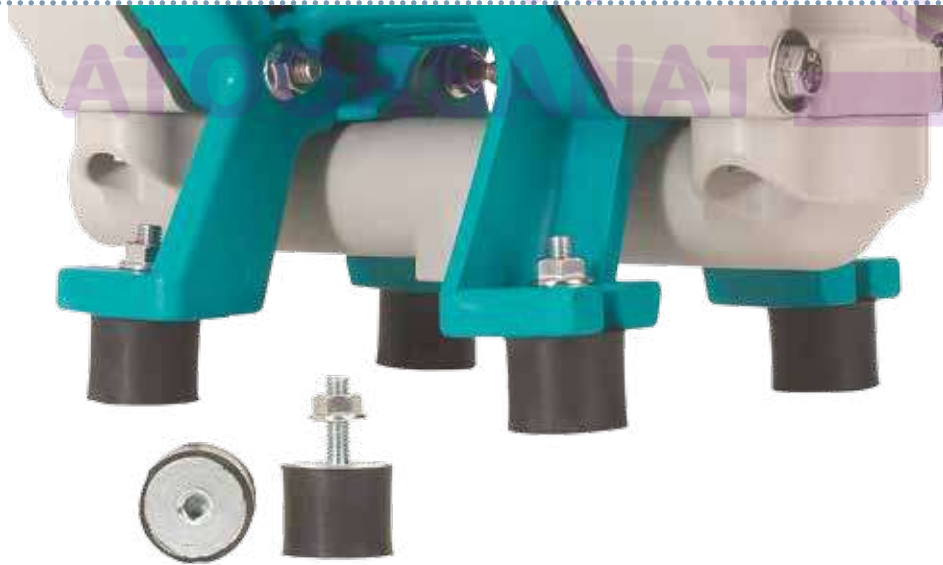

ANTI VIBRATION MOUNTINGS

Minimise the vibrations transmitted from pump to system.

- 1 Air supply input
- 2 Pump supply output
- 3 Start command
- 4 Stop command
- 5 Pump signal input
- 6 Modality selector Auto/Man.
- 7 Remote start command
- 8 Remote stop command
- 9 Light-activated output
- 10 Preselection impulse counter



آتور صنعت

ATOORSANAT



STROKE-COUNTER

Counts the number of strokes and is connected to a PCL or a counter to allow several control modes.



TROLLEY

Easy to apply on the installation site.

Find **ARGAL** in Apple **APPSTORE** and Google **PLAYSTORE** to get precious features:

- CATALOGS** all catalogues continually updated;
- CONVERTER** of the principal measure units;
- SETTINGS** to set up your pump through your smartphone or tablet



آتور صنعت
ATOORSANAT



DO YOU NEED HELP?

Just take a **PICTURE** of the pump to repair or to change. You'll get in touch with our custom care or sales office to have a quick answer.

آتور صنعت

ATOORSANAT



COPYRIGHT: ALL RIGHTS RESERVED

No part of this catalog may be reproduced or transmitted in any form or by any means, electronic or mechanical, including photocopy, recording or any information storage and retrieval system, without permission in writing from Argal Srl.

REGISTERED TRADEMARKS

Hytrel®, Keyflex® and Teflon® are registered trademarks of Dupont.
Santoprene®, is a registered trademarks of Exxon Mobil.

GRAPHIC PROJECT

Asterisko Soluzioni Creative - www.asterisko.org

MAG-DRIVE &
MECH-SEALED
CENTRIFUGAL
PUMPS

ARGAL AIR

AIR-METERING &
AODD PUMPS
PULSATION
DAMPENERS

VERTICAL SUMP
& SUBMERSIBLE
PUMPS



SELF-PRIMING
PUMPS

FILTRATION
SYSTEM

ARGAL srl

Via Labirinto, 159 - 25125 BRESCIA - (Italy)
Phone +39 030 3507011 - fax +39 030 3507077
info@argal.it - www.argalpumps.com

