

IE2 ≥ 7.5kW

ONLY FOR
EXTRA EU
MARKETS

ENERGY EFFICIENCY IE3 ≥ 7.5 kW

TECHNICAL DATA

Rotation speed: 1450 - 2900 1/min.

Operating range:

from 1 to 470 m³/h with head up to 143 metres.

Pumped liquid: clean, free of solids and abrasives, non-viscous, non-aggressive, non-crystallised and chemically neutral, with properties similar to water.

Pumped liquid temperature range: from -10°C to +140°C.

Maximum ambient temperature: +40 °C.

Maximum operating pressure:

16 bar - 1600 kPa (for DN 200 max 10 bar).

Flanging: PN 16 DIN 2533

PN 10 DIN 2532 for DN 200

Installation: normally in the horizontal position.

Special executions on requests: pumps for liquids other than water.

Packing (also externally powered).

Other voltages and/or frequencies.

APPLICATIONS

Standardised centrifugal single-stage pumps, designed for a wide range of applications, such as:

Water supply.

Hot water circulation for the heating system.

Circulation of cold water for air conditioning and refrigeration systems.

Transfer of liquids in agricultural, horticultural, and industrial environments.

Installation of pumping assemblies.

They can be coupled, using an elastic joint (standard or spacer), to a 2-pole or 4-pole electric motor, and installed on a formed metal sheet base in accordance with UNI EN 23661.

CONSTRUCTION FEATURES OF THE PUMP

Cast iron single stage spiral body complying with DIN-EN 733 (formerly DIN 24255), seal holder cover and cast iron motor support, flanges complying with DIN 2533 (DIN 2532 for DN 200). Cast iron impeller, closed and dynamically balanced, with compensation of the axial thrust through balancing holes, operation on interchangeable wear rings (on request). Stainless steel pump shaft supported by two permanently lubricated oversized ball bearings, housed inside an appropriate chamber in the support.

Standard seal device: standardised mechanical seal according to DIN 24960 in carbon/silicon carbide with EPDM OR rings.

Packing with lubricating hydraulic ring and stuffing box in two easily removable parts available on request.

MATERIALS

No.	PARTS	MATERIALS
1	PUMP BODY	CAST IRON 250 UNI ISO 185
4	IMPELLER	CAST IRON 200 UNI ISO 185
7A	PUMP SHAFT	AISI 420 STAINLESS STEEL UNI 6900/71
28	OR RING	VITON
36	SEAL HOLDING DISC	CAST IRON 250 UNI ISO 185
16	MECHANICAL SEAL	CARBON/SILICON CARBIDE
31	SEAL SPACER	AISI 304 STAINLESS STEEL UNI 6900/71

No.	PARTS	MATERIALS
58	SEAL BUSHING	AISI 420 STAINLESS STEEL UNI 6900/71
141	HYDRAULIC RING	AISI 304 STAINLESS STEEL UNI 6900/71
142	STUFFING BOX	RAMIE IMPREGNATED PTFE

STANDARD VERSION
WITH MECHANICAL SEAL

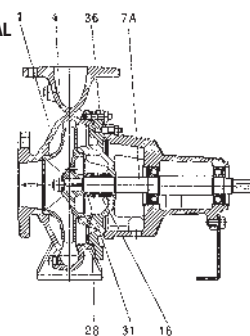

VERSION ON REQUEST
WITH PACKING

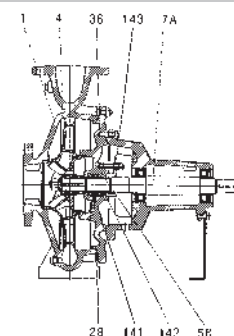

DENOMINATION INDEX

In the description of the bare shaft pump no mention is made of the coupling or motor data.

In the description of the pumps mounted on a base without a motor, the motor data are not mentioned.

The example given describes an NK 100-200 type pump with a cast iron 198 Ø impeller, with BAQE type mechanics, standard coupling and 4-poles 5,5 kW motor running on 380-415 V 50 Hz.

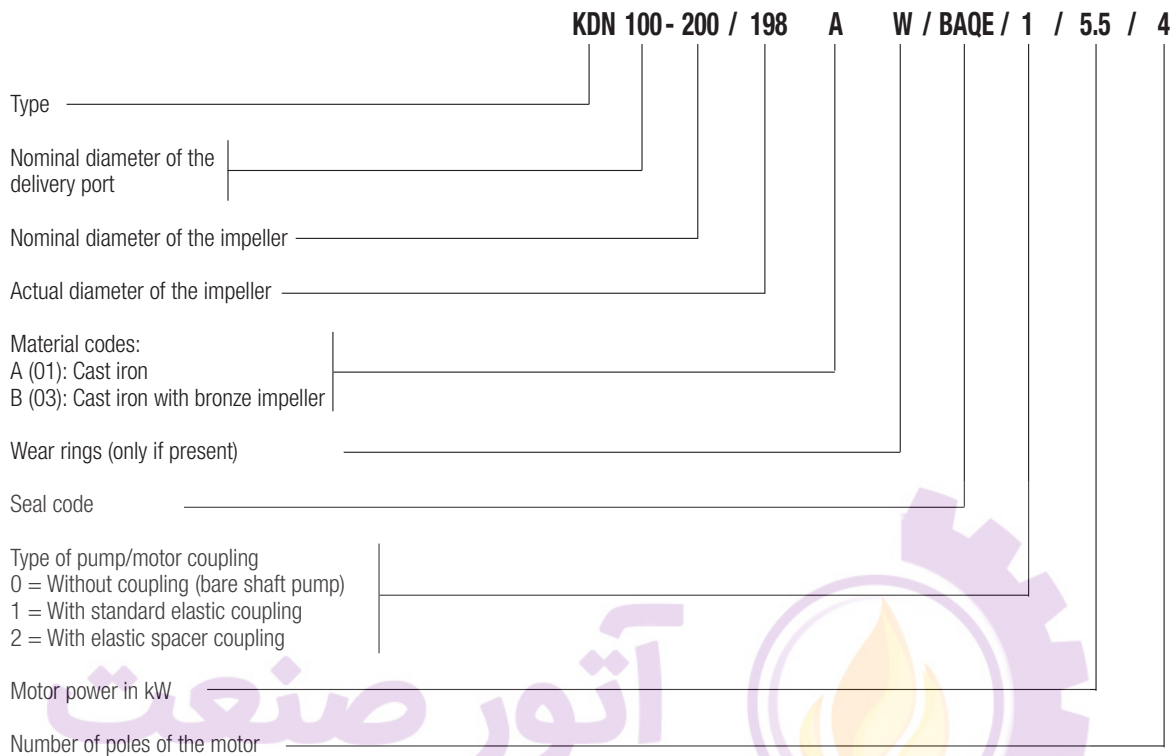

PUMP MATERIAL CODES

Component	VERSION	
	A (01) cast iron	B (03) cast iron with bronze impeller
Pump body	GG25	GG25
SEAL HOLDER DISC	GG25	GG25
Stuffing box	OT Cu 62 Si1	OT Cu 62 Si1
Impeller	GG25	GCuSn5Zn5Pb5 UNI 7013/8a-72
Wear rings*	GG20	GG20
Pump shaft	AISI 420 UNI 6900/71	
Shaft sleeve*	AISI 420 UNI 6900/71	

DESCRIPTION OF THE MECHANICAL SEAL

Position	Code	Description of the seal
1	A	O-ring seal with fixed guide
	B	Rubber bellows seal
	C	O-ring seal with spring guide
	D	O-ring seal balanced
	M	Rubber bellows seal
	X	Metal bellows seal
Position	Code	Materials
2 & 3	A	Impregnated carbon/metal
	B	Impregnated carbon/resin
	C	Other carbon types
	S	Chromium steel
	U	Tungsten carbide
	Q	Silicon carbide
	V	Aluminium oxide (ceramic)
	X	Other ceramic types
Position	Code	Materials
4	P	Nitrile rubber (NBR)
	S	Silicon rubber
	T	Teflon (PTFE)
	E	EPDM
	V	Viton
M	PTFE coated O-ring	
Position	Code	Materials
5	v	Reinforced

PACKING CODES

Position	Code	Description of the packing
1	S	Stuffing box type
Position	Code	Cooling
2	N	Stuffing box not cooled
	K	Stuffing box cooled
Position	Code	Sealing liquid
3	E	With internal liquid
	F	With external liquid
	O	Without hydraulic ring

* On request

** Only for packing or balanced mechanical seal.

PRODUCT CODE DESCRIPTION

NOMINAL DIAMETER OF THE IMPELLER	Cod.
125	1
160	2
200	3
250	4
315	5
125.1	K
160.1	L
200.1	M

PUMP TYPE	Cod.
KDN 32	1
KDN 40	2
KDN 50	3
KDN 65	4
KDN 80	5
KDN 100	6
KDN 125	7
KDN 150	8

IDENTIFICATION	Cod.
DAB PUMPS S.p.A.	D

	Cod.
DAB PUMPS S.p.A.	1

Cod.	PUMP/IMPELLER MATERIALS
1	A (01) = cast iron/cast iron
2	B (03) = cast iron/bronze
3	
4	
5	A (01) + Wr*
6	B (03) + Wr*
7	
8	

Cod.	SEAL DEVICE
1	BAQE
2	BAQE-RMG12
5	BQQV*
7	BAQV*
A	SNE*
B	SNO*
C	SNF*
G	BQQE*

* On request

Cod.	JOINT
0	Without joint
1	With standard elastic coupling
2	With elastic spacer coupling

* Bare shaft pump

Cod.	VOLTAGE	PO-LES
0	Without motor	
1	3 x 220-240/380-415 V 50 Hz(<0,75 kW) 3 x 220-277/380-480 V 60 Hz	2
2	3 x 380-480 V 60 Hz	2
3	3 x 220-240/380-415 V 50 Hz(<0,75 kW) 3 x 220-277/380-480 V 60 Hz	4
4	3 x 380-480 V 60 Hz	4
A	3 x 220-240/380-415 V 50 Hz - IE2	2
B	3 x 380-415 V 50 Hz - IE2	2
C	3 x 220-240/380-415 V 50 Hz - IE2	4
D	3 x 380-415 V 50 Hz - IE2	4
U	3 x 220-240/380-415 V 50 Hz - IE3	2
V	3 x 380-415 V 50 Hz - IE3	2
W	3 x 220-240/380-415 V 50 Hz - IE3	4
X	3 x 380-415 V 50 Hz - IE3	4

Product code

1 D 1 1 1 1 1 1 1

← Bare shaft pump → 0 0 0
 ← Pump with base without motor → 0
 ← Complete electric pump with base →

GENERAL DATA

Supplied with closed asynchronous type motor, external ventilation cooling, 2 or 4 poles.

Rotor running on ball bearings, largely oversized to ensure low noise and durability.

Electrical protection: in compliance with the EEC 89/336 ELECTROMAGNETIC COMPATIBILITY DIRECTIVE and subsequent amendments, the EEC 73/23 LOW VOLTAGE DIRECTIVE and subsequent amendments, as well as CEI 2-3 standards.

INSTRUCTIONS FOR THE IDENTIFICATION OF THE PUMP AND MOTOR REQUIRED.

1. On the general chart supplied, find the family pump that indicatively offers the required flow rate and head characteristics.

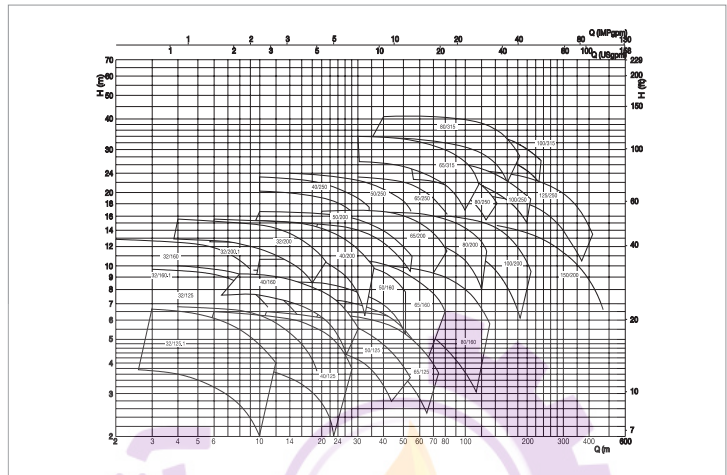

2. Look for the most appropriate characteristic on the characteristic curves for each family.

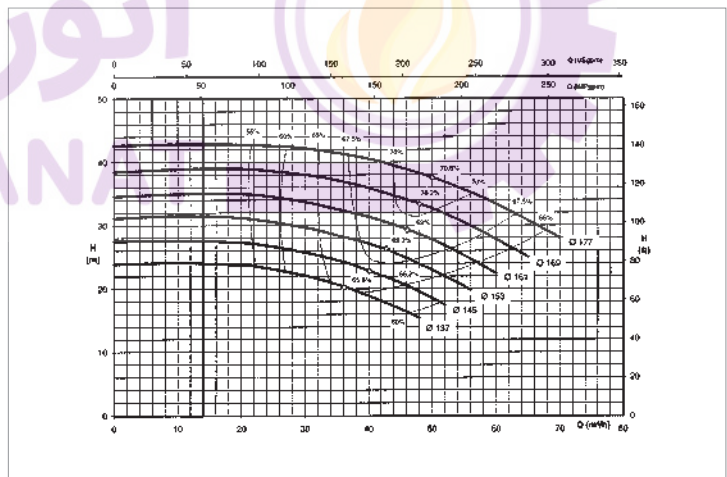

3. On the power chart, identify the power required by the pump in order to operate at the required level.

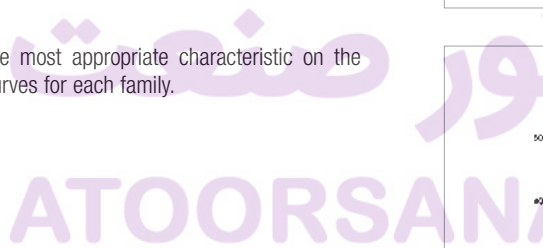
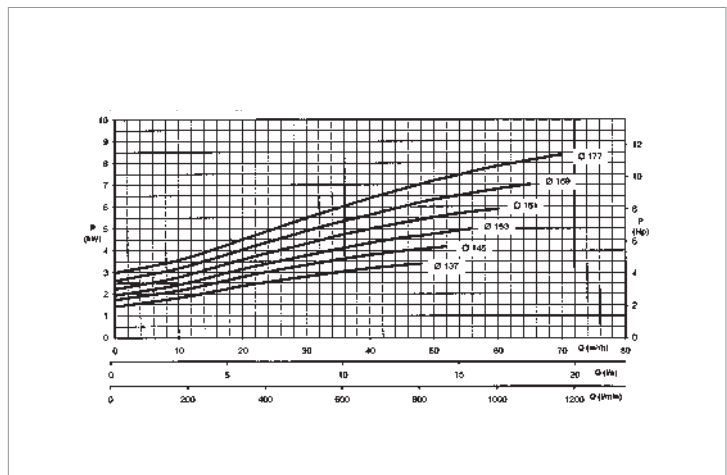

4. Due to the possibility of variations in the pumped liquid flow rate, which can cause an oscillation of the point of operation, a higher power absorption may occur. When selecting the motor, allow for the following safety margins:

Safety margin according to ISO 5199

REQUIRED PUMP SHAFT POWER (kW)	POWER OF THE MOTOR TO USE P2 (kW)
322	355
286	315
227	250
181	200
145	160
120	132
100	110
81	90
68	75
49	55
40	45
32.5	37
26	30
19	22
15.9	18.5
12.8	15
9.1	11
6.1	7.5
4.3	5.5
3.2	4
2.3	3
1.7	2.2
1.1	1.5
0.81	1.1
0.55	0.75
0.40	0.55
0.27	0.37
0.18	0.25

If the pump is to be used with liquids with fairly high specific weight and viscosity values, apply any required corrections to the power of the motor to be installed (check the suitability of the construction materials in contact with the liquid).

5. With the name of the pump and the power of the motor, look through the following technical data to find the name of the most suitable base (complete with motor, spacer coupling, and coupling cover).
6. The pump and base required will be delivered already assembled and aligned, although an alignment check is always required after installation (see INSTRUCTION MANUAL).

Ambient temperature

From -30 °C to +40 °C

Due to the low density, and therefore low cooling effect of the air, operation at an ambient temperature above 40 °C, or at an altitude exceeding 1000 m above sea level, requires a reduction of the rated motor load in accordance with this table.

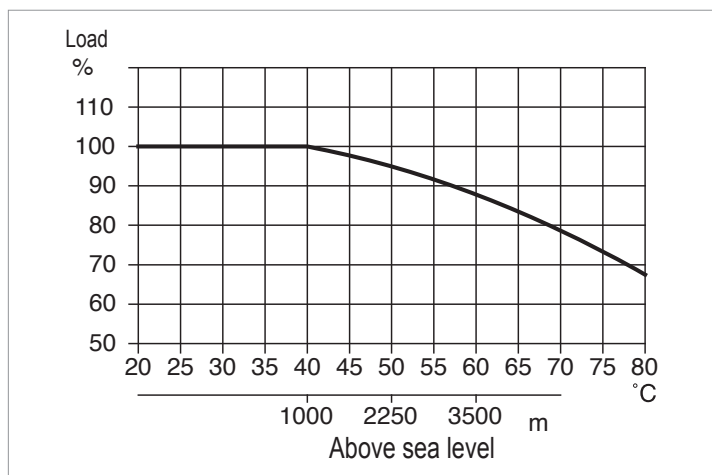

DIMENSIONS OF BARE SHAFT PUMPS

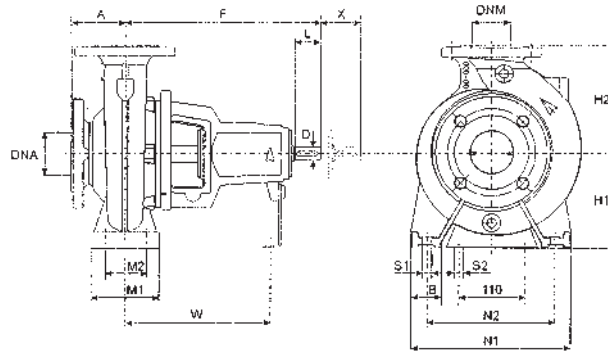

MODEL	η MAX 1450 min ⁻¹		η MAX 2900 min ⁻¹		FLANGE DIMENSIONS		PUMP DIMENSIONS				BASE DIMENSIONS					BOLT HOLES		SHAFT END		X	WEIGHT kg	
	Q m ³ /h	H m	Q m ³ /h	H m	DNA	DNM	A	F	H1	H2	B	M1	M2	N1	N2	W	S1	S2	D			L
KDN 32-125.1	10.5	5.5	20.9	22	50	32	80	360	112	140	50	100	70	190	140	260	M12	M12	24	50	100	37
KDN 32-125	13.6	5.8	28	22.8	50	32	80	360	112	140	50	100	70	190	140	260	M12	M12	24	50	100	36
KDN 32-160.1	8.7	8.3	17.5	33	50	32	80	360	132	160	50	100	70	240	190	260	M12	M12	24	50	100	38
KDN 32-160	15.9	8.6	31	34	50	32	80	360	132	160	50	100	70	240	190	260	M12	M12	24	50	100	38
KDN 32-200.1	8.5	11.4	18	45	50	32	80	360	160	180	50	100	70	240	190	260	M12	M12	24	50	100	46
KDN 32-200	17.7	13.2	35.5	52.5	50	32	80	360	160	180	50	100	70	240	190	260	M12	M12	24	50	100	46
KDN 40-125	21.8	5.6	46	21.5	65	40	80	360	112	140	50	100	70	210	160	260	M12	M12	24	50	100	39
KDN 40-160	25.8	9.2	50	37.2	65	40	80	360	132	160	50	100	70	240	190	260	M12	M12	24	50	100	41
KDN 40-200	29	12.6	57	51	65	40	100	360	160	180	50	100	70	265	212	260	M12	M12	24	50	100	49
KDN 40-250	31	19.1	62	77	65	40	100	360	180	225	65	125	95	320	250	260	M12	M12	24	50	100	57
KDN 50-125	41	5.4	83	21.5	65	50	100	360	132	160	50	100	70	240	190	260	M12	M12	24	50	100	42
KDN 50-160	43.3	9.3	87.5	37	65	50	100	360	160	180	50	100	70	265	212	260	M12	M12	24	50	100	44
KDN 50-200	41	14	81	56	65	50	100	360	160	200	50	100	70	265	212	260	M12	M12	24	50	100	51
KDN 50-250	49	19.1	100	76	65	50	100	360	180	225	65	125	95	320	250	260	M12	M12	24	50	100	59
KDN 65-125	57	5.2	114	21	80	65	100	360	160	180	65	125	95	280	212	260	M12	M12	24	50	100	46
KDN 65-160	61	8.6	121	34.5	80	65	100	360	160	200	65	125	95	280	212	260	M12	M12	24	50	100	47
KDN 65-200	62	14.8	123	59	80	65	100	360	180	225	65	125	95	320	250	260	M12	M12	24	50	140	66
KDN 65-250	65.4	20	129	81	80	65	100	470	200	250	80	160	120	360	280	340	M16	M12	32	80	140	93
KDN 65-315	84	31.5	-	-	80	65	125	470	225	280	80	160	120	400	315	340	M16	M12	32	80	140	112
KDN 80-160	101	8.1	195	33.5	100	80	125	360	180	225	65	125	95	320	250	260	M12	M12	24	50	140	55
KDN 80-200	101	14.4	200	57.5	100	80	125	470	180	250	65	125	95	345	280	340	M12	M12	32	80	140	84
KDN 80-250	103	23	215	88	100	80	125	470	200	280	80	160	120	400	315	340	M16	M12	32	80	140	104
KDN 80-315	136	35	-	-	100	80	125	470	250	315	80	160	120	400	315	340	M16	M12	32	80	140	122
KDN 100-200	163	13.4	315	53	125	100	125	470	200	280	80	160	120	360	280	340	M16	M12	32	80	140	96
KDN 100-250	159	21.8	313	87	125	100	140	470	225	280	80	160	120	400	315	340	M16	M12	32	80	140	111
KDN 100-315	187	34.1	-	-	125	100	140	470	250	315	80	160	120	400	315	340	M16	M12	32	80	140	126
KDN 125-250	289	20.5	-	-	150	125	140	470	250	355	80	160	120	400	315	340	M16	M12	32	80	140	135
KDN 150-200	378	10	-	-	200	150	160	470	280	400	100	200	150	550	450	340	M20	M12	32	80	140	178

FLANGE DIMENSIONS (mm)

	Nominal diameter (DN)								
	DIN 2533 PN 16								DIN 2533 PN 10
	32	40	50	65	80	100	125	150	200
D(32	40	50	65	80	100	125	150	200
D)	100	110	125	145	160	180	210	240	295
D[140	150	165	185	200	220	250	285	340
S	18	18	18	18	18	18	18	22	22
NO. OF HOLES	4	4	4	4	8	8	8	8	8

KDN - 4 POLE RANGE

STANDARDISED CENTRIFUGAL ELECTRIC PUMPS

PERFORMANCE RANGE

The performance curves are based on kinematic viscosity values = 1 mm²/s and density equal to 1000 kg/m³. Curve tolerance according to ISO 9906.

GRAPHIC SELECTION TABLE

= 1450 1/min

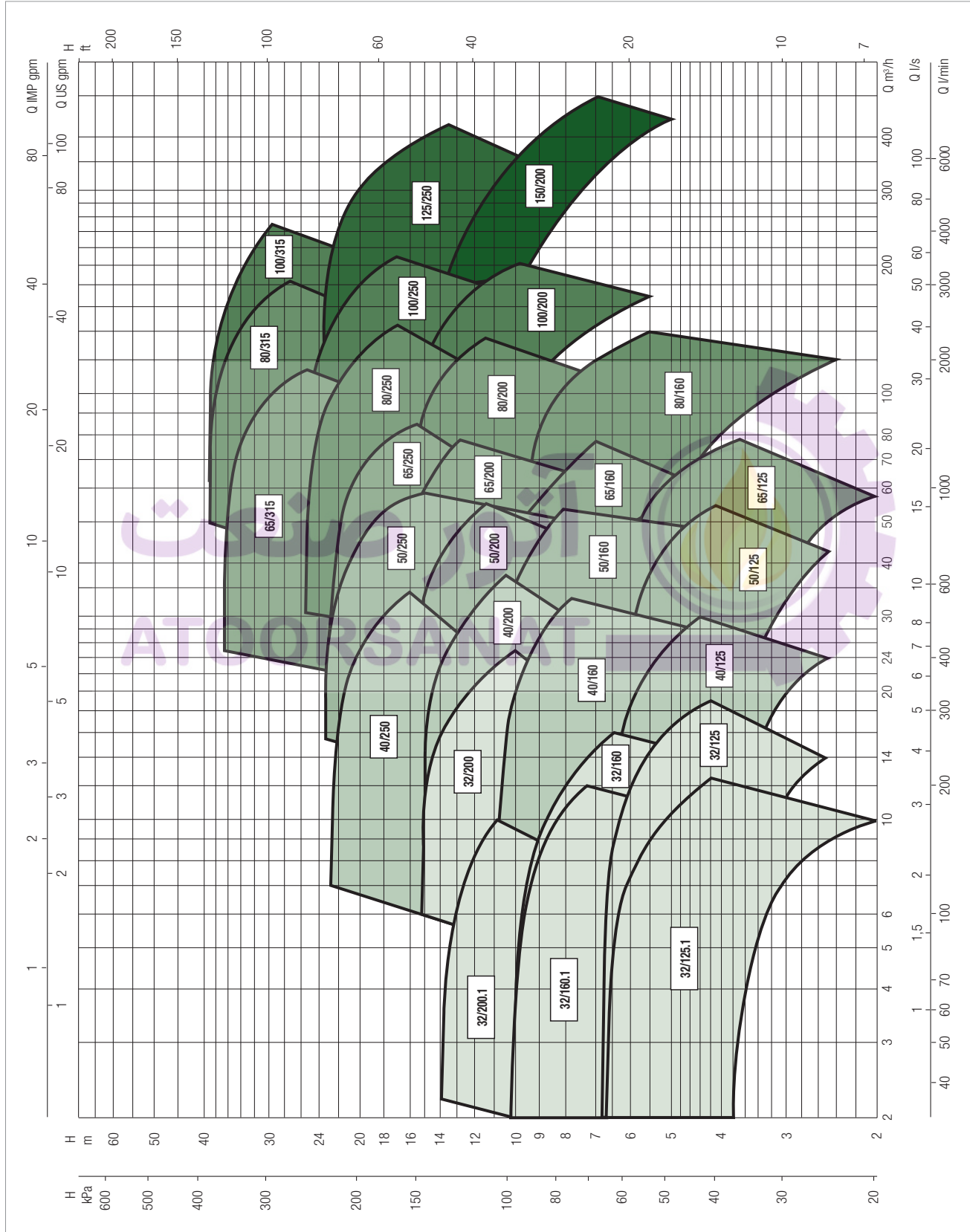

KDN - 4 POLES

STANDARDISED CENTRIFUGAL ELECTRIC PUMPS

SELECTION TABLE - KDN 32

MODEL	Q=m ³ /h	0	3	6	12	18	24
	Q=l/min	0	50	100	200	300	400
KDN 32-125.1/105		3.5	3.4	3.1			
KDN 32-125.1/110		3.9	3.8	3.5			
KDN 32-125.1/115		4.25	4.2	3.9			
KDN 32-125.1/120		4.7	4.6	4.3			
KDN 32-125.1/125		5.1	5.1	4.8			
KDN 32-125.1/130		5.6	5.6	5.3			
KDN 32-125.1/135		6.1	6	5.8	4.4		
KDN 32-125.1/140		6.6	6.6	6.4	5.1		
KDN 32-125/115		4.3		4.1	3.2		
KDN 32-125/120		4.75		4.6	3.75		
KDN 32-125/125		5.2		5.05	4.2		
KDN 32-125/130		5.7		5.5	4.8		
KDN 32-125/135		6.2		6	5.3	3.65	
KDN 32-125/142		6.9		6.75	6.15	4.5	
KDN 32-160.1/137		5.3	5.3	4.7			
KDN 32-160.1/145		6.2	6.1	5			
KDN 32-160.1/153		7	7	6.6			
KDN 32-160.1/161		8	7.9	7.6			
KDN 32-160.1/169		8.9	8.9	8.6	5.5		
KDN 32-160.1/177		9	9.8	9.5	6.6		
KDN 32-160/137		5.9		5.6	4.4		
KDN 32-160/145		6.7		6.5	5.3		
KDN 32-160/153		7.6		7.4	6.25		
KDN 32-160/161		8.5		8.25	7.25		
KDN 32-160/169		9.5		9.3	8.4	6.6	
KDN 32-160/177		10.5		10.4	9.6	7.8	
KDN 32-200.1/170		8.6	8.5	7.2			
KDN 32-200.1/180		9.8	9.8	9			
KDN 32-200.1/190		11.3	11.1	10.5			
KDN 32-200.1/200		12.8	12.7	11.7	8.3		
KDN 32-200.1/207		13.8	13.8	13	8.9		
KDN 32-200/170		8.6		8.2	6.7		
KDN 32-200/180		9.9		9.6	8.2		
KDN 32-200/190		11.2		10.9	9.7	7	
KDN 32-200/200		12.6		12.3	11.1	8.7	
KDN 32-200/210		14.3		14	13.1	10.7	
KDN 32-200/219		15.7		15.4	14.8	13	9.8

TABELLA DI SELEZIONE - KDN 40

MODEL	Q=m ³ /h	0	6	12	18	24	30	36
	Q=l/min	0	100	200	300	400	500	600
KDN 40-125/115	H (m)	4.2	4.1	3.8	3.2	2.4		
KDN 40-125/120		4.6	4.5	4.2	3.7	2.9		
KDN 40-125/125		5.1	4.9	4.7	4.1	3.3		
KDN 40-125/130		5.5	5.4	5.2	4.7	3.9		
KDN 40-125/135		6	5.9	5.8	5.3	4.6		
KDN 40-125/142		6.7	6.6	6.5	6	5.3	4.1	
KDN 40-160/137		5.9	5.8	5.8	5	3.7		
KDN 40-160/145		6.7	6.6	6.5	6	4.8		
KDN 40-160/153		7.6	7.6	7.5	7	6.8		
KDN 40-160/161		8.6	8.5	8.4	8	7.1	5.6	
KDN 40-160/169		9.6	9.5	9.5	9.1	8.3	7	
KDN 40-160/177		10.7	10.7	10.6	10.2	9.5	8.3	
KDN 40-200/170		8.4	8.4	8.2	7.4	5.7		
KDN 40-200/180		9.7	9.7	9.4	8.8	7.2		
KDN 40-200/190		10.9	10.8	10.7	10.2	8.8	6.8	
KDN 40-200/200		12.2	12.1	12	11.7	10.4	8.6	
KDN 40-200/210		13.6	13.5	13.5	13.2	12.1	10.6	
KDN 40-200/219		15	15	15	14.7	13.8	12.4	10.4
KDN 40-250/220		15.8		15.6	14.8	13.6	12	
KDN 40-250/230		17.4		17.2	16.5	15.3	13.7	
KDN 40-250/240	19.1		19	18.2	17	15.5		
KDN 40-250/250	20.7		20.6	20	18.9	17.5		
KDN 40-250/260	22.7		22.6	22.1	21	19.5		

KDN - 4 POLES

STANDARDISED CENTRIFUGAL ELECTRIC PUMPS

SELECTION TABLE - KDN 50

MODEL	Q=m ³ /h	0	12	18	24	30	36	42	48	54
	Q=l/min	0	200	300	400	500	600	700	800	900
KDN 50-125/115	H (m)	4.2	4.1	3.9	3.6	3.3	2.9	2.3		
KDN 50-125/120		4.6	4.4	4.3	4	3.7	3.3	2.8		
KDN 50-125/125		5	4.9	4.7	4.5	4.2	3.7	3.3		
KDN 50-125/130		5.6	5.4	5.2	5	4.7	4.2	3.8	3.2	
KDN 50-125/135		6	5.8	5.7	5.5	5.2	4.8	4.3	3.8	
KDN 50-125/139		6.3	6.2	6.1	5.9	5.6	5.2	4.8	4.2	
KDN 50-125/144		6.7	6.7	6.6	6.4	6.2	5.8	5.3	4.8	4.1
KDN 50-160/137		6	6	5.9	5.6	5.2	4.8			
KDN 50-160/145		6.8	6.7	6.7	6.5	6.2	5.8			
KDN 50-160/153		7.6	7.6	7.5	7.4	7.2	6.7			
KDN 50-160/161		8.4	8.4	8.3	8.2	8.1	7.7			
KDN 50-160/169		9.4	9.3	9.2	9.2	9.1	8.8			
KDN 50-160/177		10.4	10.3	10.3	10.2	10.1	9.95			
KDN 50-200/170		9.5	9.3	9.2	8.8	8	6.85			
KDN 50-200/180		10.6	10.6	10.5	10.1	9.5	8.6	7.3		
KDN 50-200/190		11.8	11.7	11.6	11.4	10.8	10.1	8.9		
KDN 50-200/200		13.1	13	13	12.8	12.3	11.6	10.6	9.4	
KDN 50-200/210		14.6	14.6	14.5	14.4	13.9	13.2	12.2	11	
KDN 50-200/219		16	16	16	15.9	15.4	14.2	13.8	12.7	11.4
KDN 50-250/220		15.9	15.7	15.6	15.4	14.9	13.8	12.4	10.5	xxx
KDN 50-250/230	17.4	17.3	17.2	17	16.5	15.5	14.2	12.6	10.3	
KDN 50-250/240	19	19	19	18.8	18.2	17.4	16.2	14.7	12.4	
KDN 50-250/250	20.8	20.8	20.7	20.6	20.1	19.2	18.1	17	14.8	
KDN 50-250/263	23	23	22.9	22.8	22.5	21.7	20.6	19.4	17.5	

SELECTION TABLE - KDN 65

MODEL	Q=m ³ /h	0	18	24	30	36	42	48	54	60	66	72	78	84	90	102	114
	Q=l/min	0	300	400	500	600	700	800	900	1000	1100	1200	1300	1400	1500	1700	1900
KDN 65-125/120/110		3.75		3.5	3.3	3.2	2.9	2.7	2.3	1.9							
KDN 65-125/120		4.25		3.9	3.8	3.6	3.3	3.1	2.7	2.3							
KDN 65-125/125		4.7		4.4	4.25	4.1	3.8	3.6	3.25	2.8							
KDN 65-125/130		5.1		4.9	4.75	4.6	4.3	4.1	3.8	3.3	2.8						
KDN 65-125/135		5.6		5.4	5.3	5.2	4.9	4.7	4.3	3.9	3.5	3					
KDN 65-125/140		6		5.9	5.8	5.7	5.5	5.2	4.9	4.5	4.1	3.6					
KDN 65-125/144		6.4		6.35	6.25	6.2	5.9	5.7	5.4	5	4.65	4.2	3.7				
KDN 65-160/137		5.8		5.7	5.4	5.2	4.75	4.3	3.7								
KDN 65-160/145		6.5		6.5	6.3	6	5.7	5.3	4.75	4.1							
KDN 65-160/153		7.3		7.2	7.2	6.9	6.7	6.3	5.8	5.25							
KDN 65-160/161		8.2		8.1	8.1	7.9	7.7	7.3	6.85	6.3	5.8						
KDN 65-160/169		9.1		9.1	9	8.9	8.7	8.4	8	7.6	7.1	6.4					
KDN 65-160/177		10		10	9.9	9.8	9.7	9.45	9.1	8.7	8.2	7.5					
KDN 65-200/170		9.3	9.3	9.2	9.2	9	8.5	7.9	7.1	6.3							
KDN 65-200/180	H (m)	10.4	10.4	10.4	10.3	10.2	10	9.5	8.8	8.1							
KDN 65-200/190		12.1	12	12	12	11.9	11.5	11.1	10.5	9.8	8.8						
KDN 65-200/200		13.3	13.3	13.3	13.2	13.1	13	12.8	12.3	11.6	10.8						
KDN 65-200/210		14.8	14.7	14.7	14.7	14.6	14.6	14.3	13.8	13.4	12.7	12					
KDN 65-200/219		16.2	16.2	16.2	16.1	16	15.9	15.8	15.4	15	14.4	13.5	12.7				
KDN 65-250/220		15.8		15.8	15.5	15.1	14.5	14	13.2	12	10.7						
KDN 65-250/230		17.4		17.4	17.2	16.8	16.3	15.7	15	14.1	12.7	11.4					
KDN 65-250/240		19		19	18.9	18.5	18.1	17.5	16.8	16	14.7	13.6					
KDN 65-250/250		20.7		20.7	20.6	20.4	20	19.5	18.8	18	17	15.9	14.5				
KDN 65-250/263		23.2		23	23	22.9	22.5	22.2	21.6	20.8	19.8	18.6	17.4	16			
KDN 65-315/260		22.3		22.2	22.1	22	21.5	21	20.5	20	19.2	18.4	17	16	15		
KDN 65-315/275		25.1		25.1	25	24.8	24.6	24.1	23.5	23	22.5	21.5	20.5	19.4	18.1		
KDN 65-315/290		28.2		28.2	28.1	28	27.8	27.3	27	26.5	25.5	25	24	23.1	22	19.5	
KDN 65-315/305		31.7		31.5	31.4	31.4	31.3	31.2	30.8	30.4	29.6	29	28	27.2	26.1	23.5	
KDN 65-315/320		35.7		35.4	35.3	35.2	35.1	35	34.8	34.5	33.8	33.5	32.5	31.5	30.8	28	24.8

KDN - 4 POLES

STANDARDISED CENTRIFUGAL ELECTRIC PUMPS

SELECTION TABLE - KDN 80

MODEL	Q=m ³ /h	0	42	48	54	60	66	72	78	84	90	102	114	120	150	180
	Q=l/min	0	700	800	900	1000	1100	1200	1300	1400	1500	1700	1900	2000	2500	3000
KDN 80-160/147/127	H (m)	5.7	5.4	5.25	5.05	4.8	4.6	4.35	4.15	3.85	3.6	3.1	2.5	2.2		
KDN 80-160/153/136		6.4	6.2	6.05	5.85	5.7	5.4	5.15	4.8	4.65	4.4	3.85	3.3	3		
KDN 80-160/153		7.3	7.1	6.9	6.7	6.5	6.3	6	5.75	5.4	5.2	4.55	3.9	3.6		
KDN 80-160/161		8.2	8	7.9	7.75	7.5	7.3	7.05	6.8	6.5	6.25	5.6	4.9	4.6		
KDN 80-160/169		9.1	9	8.85	8.7	8.6	8.35	8.1	7.85	7.6	7.3	6.75	6	5.7		
KDN 80-160/177		10	9.9	9.85	9.8	9.7	9.5	9.3	9.1	8.85	8.7	8.1	7.25	6.9		
KDN 80-200/170		9.2	9.1	9	8.7	8.5	8.2	7.8	7.5	7.1	6.7	5.6				
KDN 80-200/180		10.3	10.2	10.2	10	9.9	9.6	9.2	9	8.6	8.2	7.2				
KDN 80-200/190		11.4	11.4	11.3	11.2	11.1	11	10.7	10.5	10.1	9.8	8.7	6.8			
KDN 80-200/200		12.7	12.6	12.6	12.6	12.5	12.4	12.3	12	11.6	11.4	10.5	9.4	8.8		
KDN 80-200/210		14.1	14	14	14	13.9	13.8	13.7	13.6	13.3	13.1	12.1	11.2	10.6		
KDN 80-200/222		15.9	15.9	15.8	15.7	15.6	15.6	15.5	15.4	15.3	15	14.3	13.4	12.8		
KDN 80-250/220		16	15.9	15.8	15.7	15.6	15.5	15.2	14.9	14.5	13.9	12.8				
KDN 80-250/230		17.3	17.3	17.2	17.1	17	16.9	16.8	16.5	16	15.5	14.3	12.4			
KDN 80-250/240		19	19	19	18.9	18.8	18.7	18.6	18.4	18	17.6	16.6	15.3	14.6		
KDN 80-250/250		20.8	20.7	20.7	20.7	20.6	20.5	20.4	20.3	19.9	19.6	18.6	17.4	16.8		
KDN 80-250/260		22.6	22.5	22.5	22.4	22.3	22.2	22.1	22	21.8	21.4	20.6	19.6	19	15.1	
KDN 80-250/270		24.5	24.4	24.4	24.4	24.3	24.2	24.1	24	23.7	23.3	22.4	21.4	20.7	16.3	
KDN 80-315/275		24.8		24.8	24.8	24.7	24.6	24.5	24.4	24.3	24	23	21.4	20.5		
KDN 80-315/290		27.8		27.8	27.8	27.7	27.7	27.6	27.6	27.5	27.4	26.5	25	24.6	19.1	
KDN 80-315/305	31.4		31.4	31.3	31.2	31.2	31.2	31.2	31.2	30.9	30	29	28.5	24		
KDN 80-315/320	34.8		34.7	34.6	34.6	34.5	34.4	34.3	34	33.9	33.8	33.2	32.8	28.8		
KDN 80-315/334	38.3		38.2	38.2	38.2	38.2	38.2	38.1	38	37.9	37.6	37	36.9	33.1	28	

SELECTION TABLE - KDN 100

MODEL	Q=m ³ /h	0	60	66	72	78	84	90	102	114	120	150	180	210	240
	Q=l/min	0	1000	1100	1200	1300	1400	1500	1700	1900	2000	2500	3000	3500	4000
KDN 100-200/180	H (m)	10.1	10.1	10.1	10	9.9	9.7	9.5	9.1	8.5	8.3	7	5.4		
KDN 100-200/190		11.6	11.5	11.4	11.3	11.2	11.1	11	10.5	10.1	10	8.6	7		
KDN 100-200/200		12.9	12.8	12.8	12.8	12.7	12.6	12.5	12.2	11.8	11.6	10.4	8.8		
KDN 100-200/210		14.3	14.2	14.2	14.2	14.2	14.1	14	13.8	13.5	13.3	12.3	10.7	9	
KDN 100-200/219		16	15.7	15.7	15.6	15.6	15.5	15.5	15.3	15.1	15	14	12.5	10.8	
KDN 100-250/220		15.2	14.9	14.9	14.9	14.8	14.7	14.6	14.3	13.7	13.4	11.4			
KDN 100-250/230		16.9	16.7	16.7	16.6	16.5	16.4	16.3	16.1	15.7	15.3	13.6	11.1		
KDN 100-250/240		18.5	18.3	18.3	18.3	18.2	18.1	18	17.9	17.6	17.4	15.7	13.3		
KDN 100-250/250		20.1	20	20	19.9	19.8	19.7	19.6	19.5	19.4	19.2	17.6	15.4		
KDN 100-250/260		22.3	22.1	22.1	22.1	22	21.9	21.8	21.7	21.5	21.4	19.8	17.7	15.1	
KDN 100-250/270		24.3	24.3	24.3	24.3	24.3	24.3	24.2	24.1	23.7	23.5	22.1	20.1	17.3	
KDN 100-315/275		25.1	25	25	25	24.9	24.8	24.7	24.6	24.4	24	22	19		
KDN 100-315/290		28	27.9	27.9	27.9	27.9	27.8	27.7	27.6	27.5	27	25.5	23		
KDN 100-315/305		31.3	31.1	31.1	31.1	31	30.9	30.8	30.7	30.6	30.5	29	27	24	
KDN 100-315/320		34.5	34.4	34.4	34.4	34.4	34.4	34.3	34.2	34.1	34	33	31	28.1	
KDN 100-315/334		38.2	38.2	38.1	38.1	38.1	38	38	37.7	37.5	37.3	36.5	34.8	32	28.8

SELECTION TABLE - KDN 125

MODEL	Q=m ³ /h	0	102	114	120	150	180	210	240	270	300	330	360	390	420
	Q=l/min	0	1700	1900	2000	2500	3000	3500	4000	4500	5000	5500	6000	6500	7000
KDN 125-250/220	H (m)	15	14.9	14.9	14.8	14.5	14	13	11.8	10.5	9.2				
KDN 125-250/230		16.6	16.6	16.6	16.5	16.3	15.6	14.8	13.8	12.5	12.3	9.5			
KDN 125-250/240		18.2	18.1	18.1	18.1	18	17.7	16.8	15.8	14.5	13.3	11.6	10.1		
KDN 125-250/250		19.9	19.8	19.8	19.7	19.6	19.4	18.7	17.8	16.6	15.5	14	12.3		
KDN 125-250/260		21.7	21.7	21.6	21.5	21.4	21.3	20.6	19.9	18	17.7	16.3	14.6	13	
KDN 125-250/269		23.9	23.9	23.9	23.8	23.6	23.2	22.7	22.1	22.2	20.2	19	17.5	15.6	14

SELECTION TABLE - KDN 150

MODEL	Q=m ³ /h	0	102	114	120	150	180	210	240	270	300	330	360	390	420
	Q=l/min	0	1700	1900	2000	2500	3000	3500	4000	4500	5000	5500	6000	6500	7000
KDN 150-200/210/170	H (m)	8.9	8.9	8.9	8.8	8.7	8.6	8.3	7.9	7.4	6.8	6.2	5.4	4.5	
KDN 150-200/218/182		10.4	10.4	10.4	10.3	10.2	9.9	9.5	9.1	8.6	8.1	7.4	6.6	5.8	
KDN 150-200/218/200		11.4	11.4	11.4	11.4	11.2	10.9	10.6	10.1	9.7	9.2	8.5	7.8	6.9	5.9
KDN 150-200/218		12.9	12.7	12.7	12.6	12.4	12.1	11.7	11.2	10.7	10.2	9.6	8.8	8	7.1
KDN 150-200/224		13.8	13.6	13.6	13.5	13.3	13	12.6	12.2	11.7	11.2	10.6	9.9	9.2	8.2

KDN 32-125.1 - 4 POLES - STANDARDISED CENTRIFUGAL ELECTRIC PUMPS FOR AIR CONDITIONING, REFRIGERATION, IRRIGATION, DECANTING, PRESSURISATION SYSTEMS, AND INDUSTRIAL APPLICATIONS

Pumped liquid temperature range: from -10 °C to +140 °C - Maximum ambient temperature: +40°C

= 1450 1/min

CENTRIFUGAL PUMPS

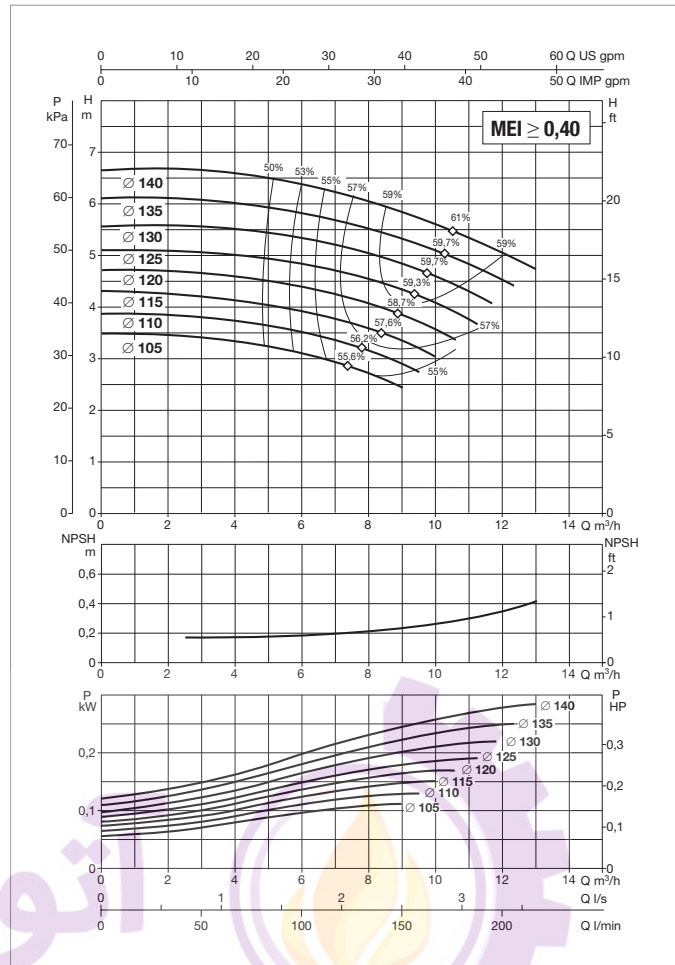
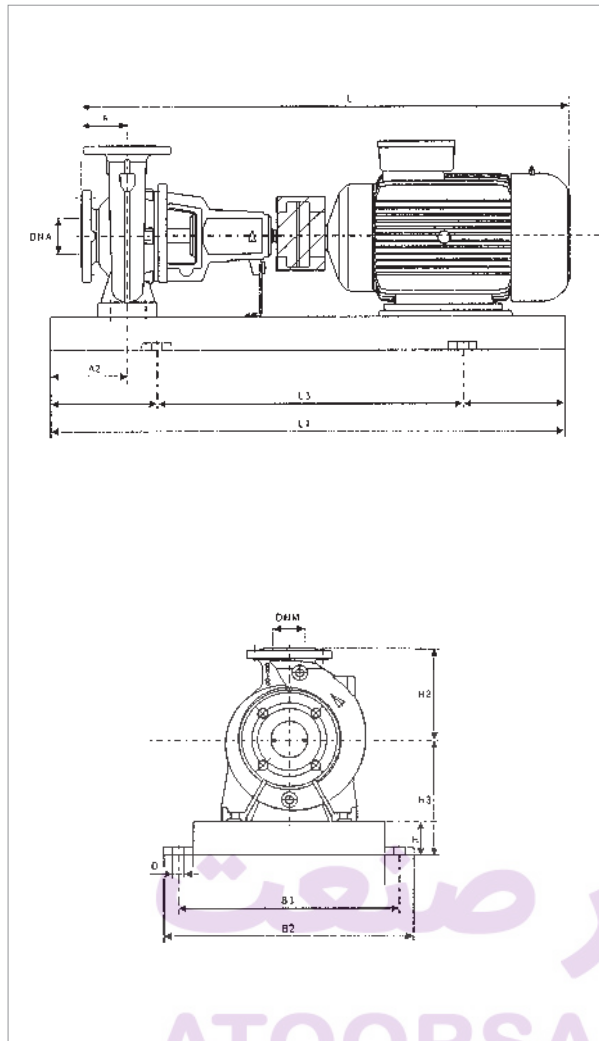

See hydraulic efficiency details on page 291.

The performance curves are based on kinematic viscosity values = 1 mm²/s and density equal to 1000 kg/m³. Curve tolerance according to ISO 9906.

MODEL	ELECTRICAL DATA			
	POWER (kW) 4 POLES	MOTOR SIZE	POWER INPUT 50 Hz	In A
KDN 32-125.1	0.37	MEC 71	3 x 230 - 400 V ~	1.7/0.975
	0.55	MEC 80	3 x 230 - 400 V ~	2.6/1.5

MODEL	POWER (kW)	UNIT DIMENSIONS (mm)										FLANGE DIMENSIONS (mm)		STANDARD COUPLING		SPACER COUPLING		REF.
		A	A2	H2	H	H3	L1	L3	B2	B3	D	DNA	DNM	L	WEIGHT kg	L	WEIGHT kg	
KDN 32-125.1	0.37	80	60	140	65	177	800	540	360	320	19	50	32	730	81	830	86	2
	0.55	80	60	140	65	177	800	540	360	320	19	50	32	730	83	830	88	2

Dimension and electrical data based on sizing definition following the instructions on page 96.

KDN 32-125 - 4 POLES - STANDARDISED CENTRIFUGAL ELECTRIC PUMPS FOR AIR CONDITIONING, REFRIGERATION, IRRIGATION, DECANTING, PRESSURISATION SYSTEMS, AND INDUSTRIAL APPLICATIONS

Pumped liquid temperature range: from -10 °C to +140 °C - Maximum ambient temperature: +40°C

= 1450 1/min

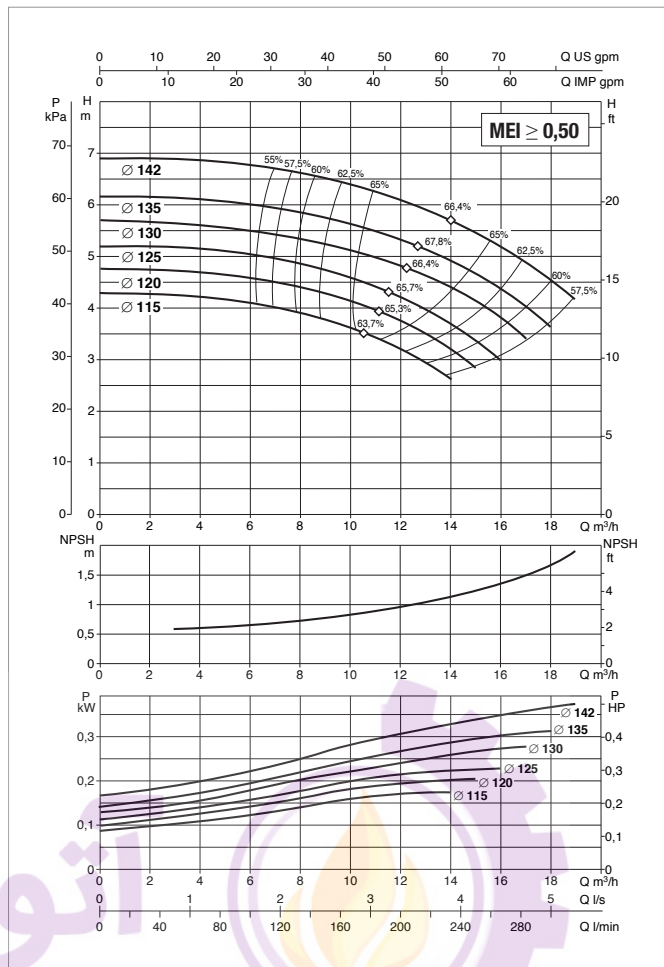
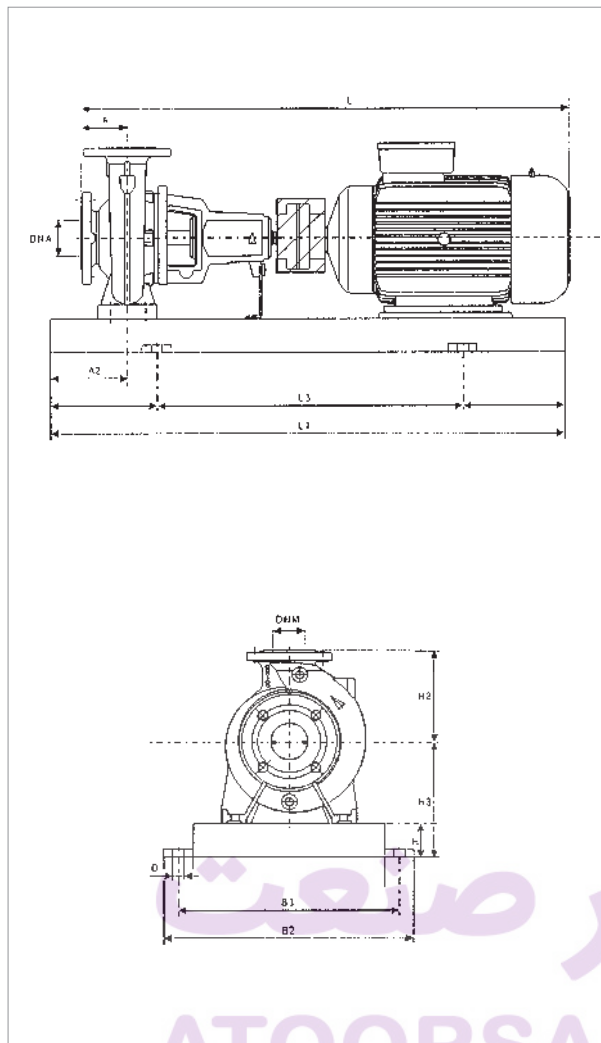

See hydraulic efficiency details on page 291.

The performance curves are based on kinematic viscosity values = 1 mm²/s and density equal to 1000 kg/m³. Curve tolerance according to ISO 9906.

MODEL	ELECTRICAL DATA					
	POWER (kW)	MOTOR SIZE	POWER INPUT 50 Hz	In A		MOTOR TYPE
	4 POLES			-	IE2	
KDN 32-125	0.37	MEC 71	3 x 230 - 400 V ~	1.7/0.975	-	-
	0.55	MEC 80	3 x 230 - 400 V ~	2.6/1.5	-	-
	0.75	MEC 80	3 x 230 - 400 V ~	-	3.57/2.06	IE2

MODEL	POWER (kW)	UNIT DIMENSIONS (mm)										FLANGE DIMENSIONS (mm)		STANDARD COUPLING				SPACER COUPLING				REF.
		A	A2	H2	H	H3	L1	L3	B2	B3	D	DNA	DNM	-		IE2		-		IE2		
		L	WEIGHT kg	L	WEIGHT kg	L	WEIGHT kg	L	WEIGHT kg	L	WEIGHT kg	L	WEIGHT kg									
KDN 32-125	0.37	80	60	140	65	177	800	540	360	320	19	50	32	730	81	-	-	830	86	-	-	2
	0.55	80	60	140	65	177	800	540	360	320	19	50	32	730	83	-	-	830	88	-	-	2
	0.75	80	60	140	65	177	800	540	360	320	19	50	32	-	-	730	84	-	-	830	89	2

Dimension and electrical data based on sizing definition following the instructions on page 96.

KDN 32-160.1 - 4 POLES - STANDARDISED CENTRIFUGAL ELECTRIC PUMPS FOR AIR CONDITIONING, REFRIGERATION, IRRIGATION, DECANTING, PRESSURISATION SYSTEMS, AND INDUSTRIAL APPLICATIONS

Pumped liquid temperature range: from -10 °C to +140 °C - Maximum ambient temperature: +40°C

= 1450 1/min

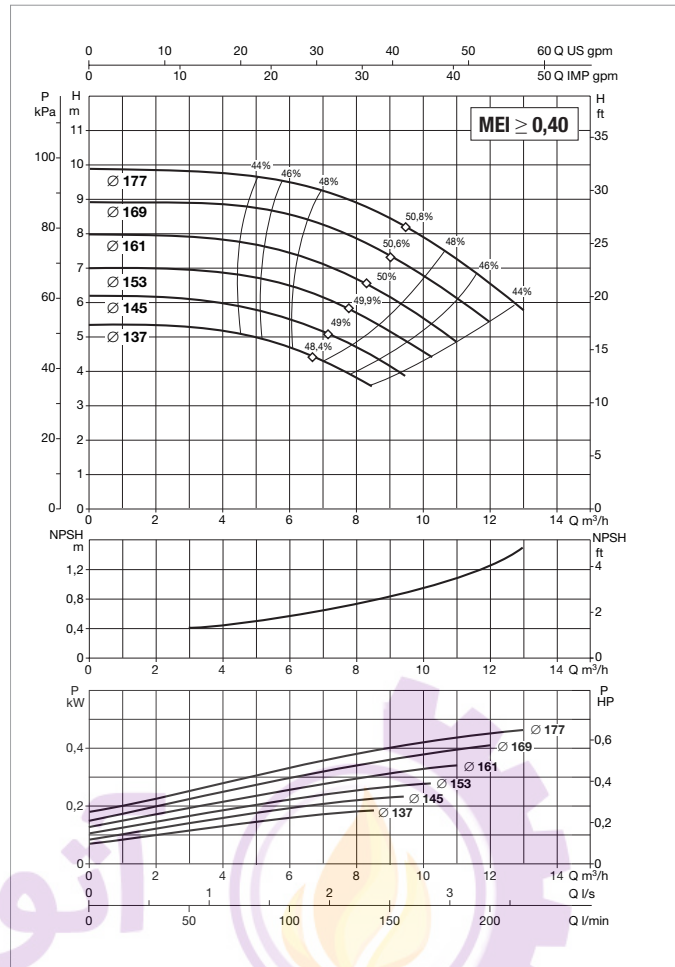
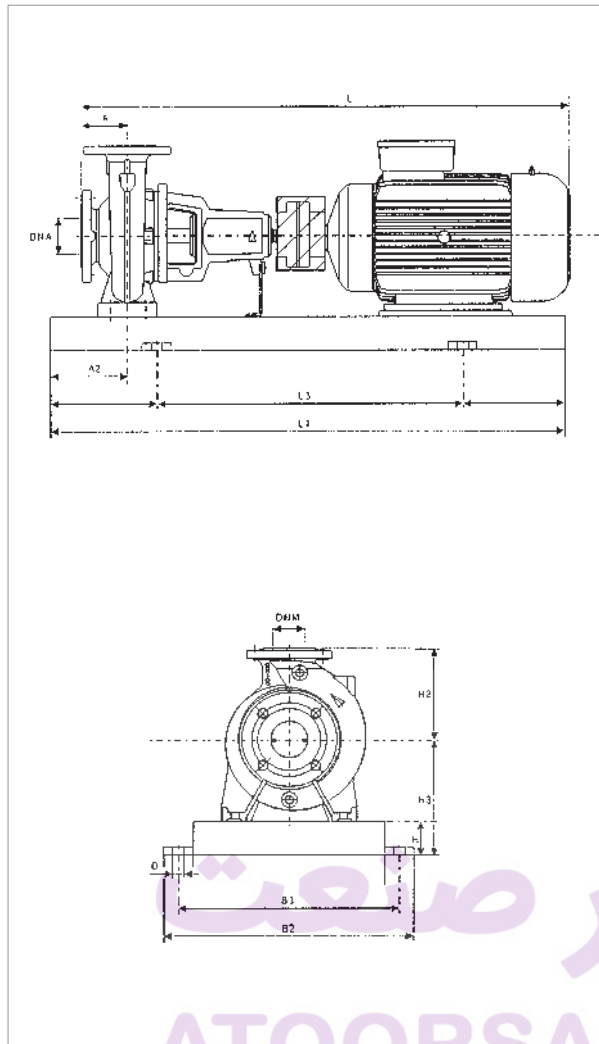

See hydraulic efficiency details on page 291.

The performance curves are based on kinematic viscosity values = 1 mm²/s and density equal to 1000 kg/m³. Curve tolerance according to ISO 9906.

MODEL	ELECTRICAL DATA					
	POWER (kW)	MOTOR SIZE	POWER INPUT 50 Hz	In A		MOTOR TYPE
	4 POLES			-	IE2	
KDN 32-160.1	0.37	MEC 71	3 x 230 - 400 V ~	1.7/0.975	-	-
	0.55	MEC 80	3 x 230 - 400 V ~	2.6/1.5	-	-
	0.75	MEC 80	3 x 230 - 400 V ~	-	3.57/2.07	IE2

MODEL	POWER (kW)	UNIT DIMENSIONS (mm)										FLANGE DIMENSIONS (mm)		STANDARD COUPLING				SPACER COUPLING				REF.
		A	A2	H2	H	H3	L1	L3	B2	B3	D	DNA	DNM	-		IE2		-		IE2		
		L	WEIGHT kg	L	WEIGHT kg	L	WEIGHT kg	L	WEIGHT kg	L	WEIGHT kg	L	WEIGHT kg	L	WEIGHT kg	L	WEIGHT kg	L	WEIGHT kg			
KDN 32-160.1	0.37	80	60	160	65	197	800	540	360	320	19	50	32	730	83	-	-	830	88	-	-	2
	0.55	80	60	160	65	197	800	540	360	320	19	50	32	730	86	-	-	830	91	-	-	2
	0.75	80	60	160	65	197	800	540	360	320	19	50	32	-	-	730	86	-	-	830	91	2

Dimension and electrical data based on sizing definition following the instructions on page 96.

KDN 32-160 - 4 POLES - STANDARDISED CENTRIFUGAL ELECTRIC PUMPS FOR AIR CONDITIONING, REFRIGERATION, IRRIGATION, DECANTING, PRESSURISATION SYSTEMS, AND INDUSTRIAL APPLICATIONS

Pumped liquid temperature range: from -10 °C to +140 °C - Maximum ambient temperature: +40°C

= 1450 1/min

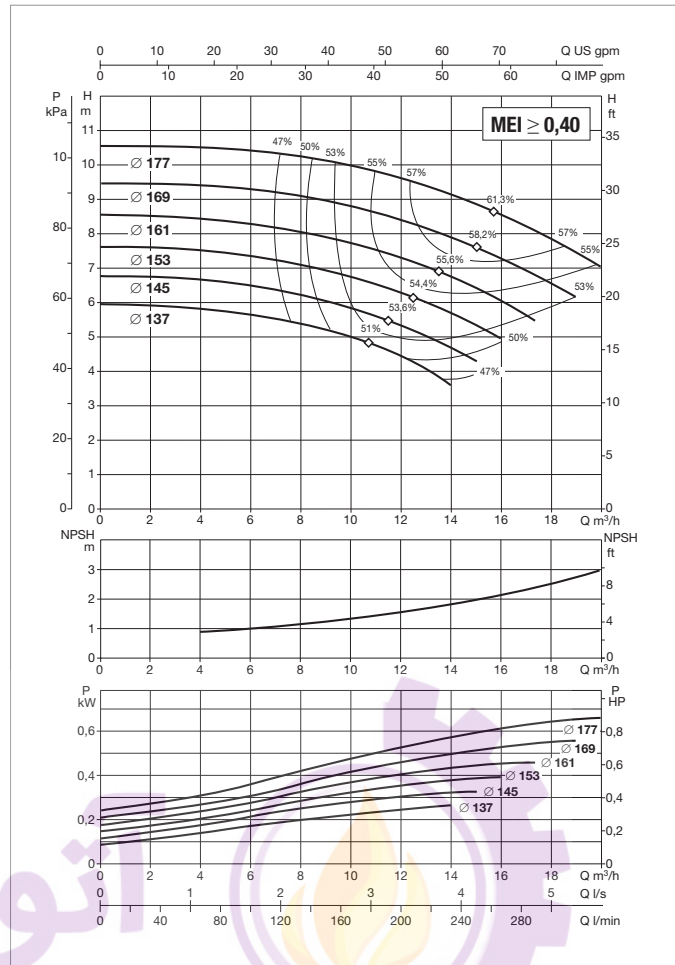
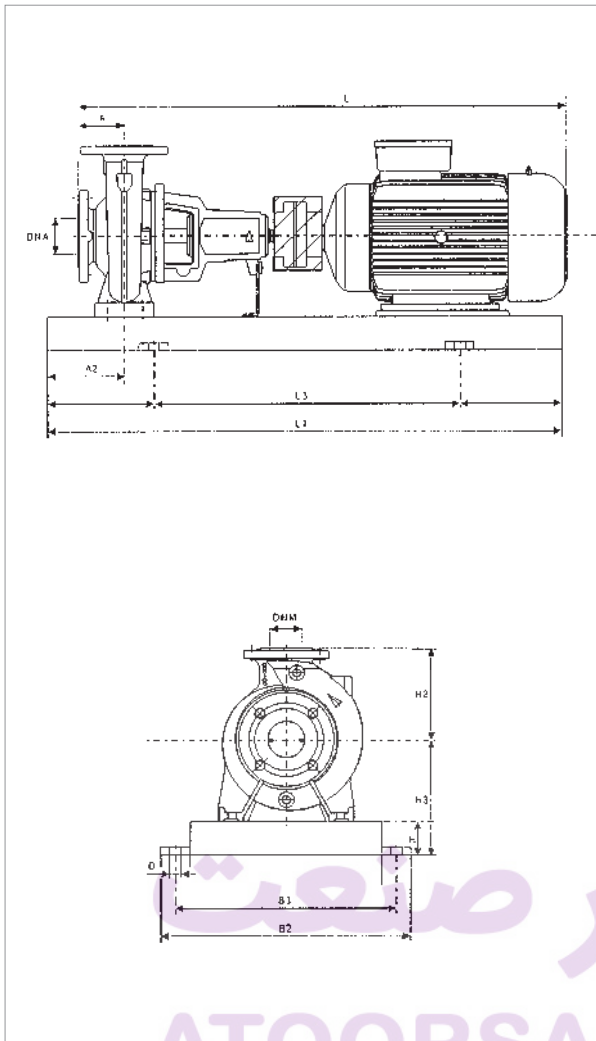

See hydraulic efficiency details on page 291.

The performance curves are based on kinematic viscosity values = 1 mm²/s and density equal to 1000 kg/m³. Curve tolerance according to ISO 9906.

MODEL	ELECTRICAL DATA					
	POWER (kW)	MOTOR SIZE	POWER INPUT 50 Hz	In A		MOTOR TYPE
	4 POLES			-	IE2	
KDN 32-160	0.37	MEC 71	3 x 230 - 400 V ~	1.7/0.975	-	-
	0.55	MEC 80	3 x 230 - 400 V ~	2.6/1.5	-	-
	0.75	MEC 80	3 x 230 - 400 V ~	-	3.57/2.07	IE2
	1.1	MEC 90S	3 x 230 - 400 V ~	-	4.68/2.7	IE2

MODEL	POWER (kW)	UNIT DIMENSIONS (mm)										FLANGE DIMENSIONS (mm)		STANDARD COUPLING				SPACER COUPLING				REF.
		A	A2	H2	H	H3	L1	L3	B2	B3	D	DNA	DNM	-		IE2		-		IE2		
														L	WEIGHT kg	L	WEIGHT kg	L	WEIGHT kg	L	WEIGHT kg	
KDN 32-160	0.37	80	60	160	65	197	800	540	360	320	19	50	32	730	83	-	-	830	88	-	-	2
	0.55	80	60	160	65	197	800	540	360	320	19	50	32	730	85	-	-	830	90	-	-	2
	0.75	80	60	160	65	197	800	540	360	320	19	50	32	-	-	730	86	-	-	830	91	2
	1.1	80	60	160	65	197	800	540	360	320	19	50	32	-	-	790	88	-	-	890	93	2

Dimension and electrical data based on sizing definition following the instructions on page 96.

KDN 32-200.1 - 4 POLES - STANDARDISED CENTRIFUGAL ELECTRIC PUMPS FOR AIR CONDITIONING, REFRIGERATION, IRRIGATION, DECANTING, PRESSURISATION SYSTEMS, AND INDUSTRIAL APPLICATIONS

Pumped liquid temperature range: from -10 °C to +140 °C - Maximum ambient temperature: +40°C

= 1450 1/min

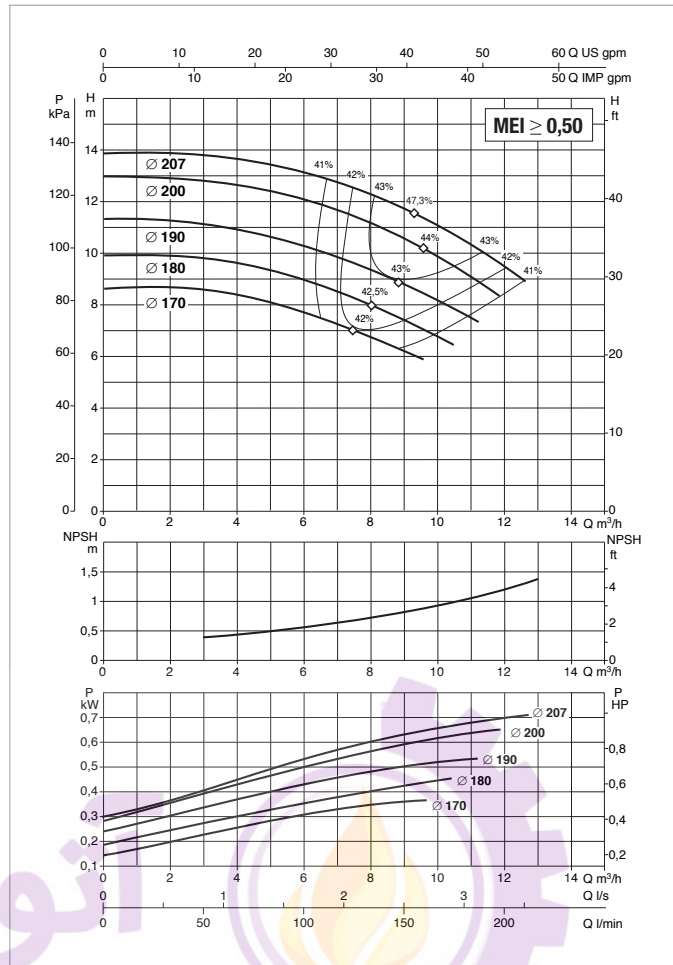
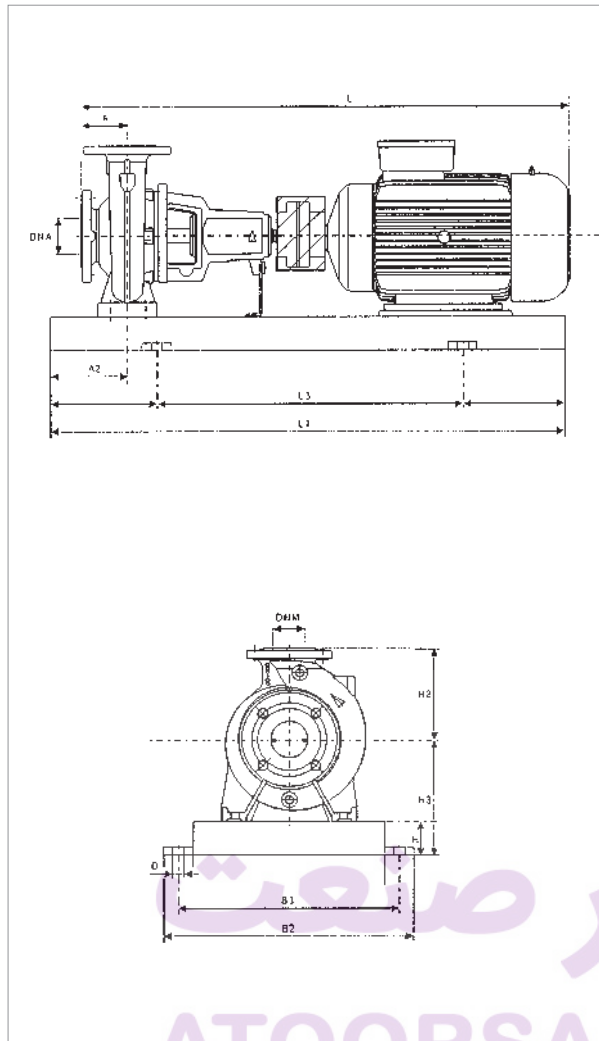

See hydraulic efficiency details on page 291.

The performance curves are based on kinematic viscosity values = 1 mm²/s and density equal to 1000 kg/m³. Curve tolerance according to ISO 9906.

MODEL	ELECTRICAL DATA					
	POWER (kW)	MOTOR SIZE	POWER INPUT 50 Hz	In A		MOTOR TYPE
	4 POLES			-	IE2	
KDN 32-200.1	0.37	MEC 71	3 x 230 - 400 V ~	1.7/0.975	-	-
	0.55	MEC 80	3 x 230 - 400 V ~	2.6/1.5	-	-
	0.75	MEC 80	3 x 230 - 400 V ~	-	3.57/2.09	IE2
	1.1	MEC 90S	3 x 230 - 400 V ~	-	4.68/2.7	IE2

MODEL	POWER (kW)	UNIT DIMENSIONS (mm)											FLANGE DIMENSIONS (mm)		STANDARD COUPLING				SPACER COUPLING				REF.
		A	A2	H2	H	H3	L1	L3	B2	B3	D	DNA	DNM	-		IE2		-		IE2			
		L	WEIGHT kg	L	WEIGHT kg	L	WEIGHT kg	L	WEIGHT kg	L	WEIGHT kg												
KDN 32-200.1	0.37	80	60	180	65	225	800	540	360	320	19	50	32	730	87	-	-	830	92	-	-	2	
	0.55	80	60	180	65	225	800	540	360	320	19	50	32	730	89	-	-	830	94	-	-	2	
	0.75	80	60	180	65	225	800	540	360	320	19	50	32	-	-	730	101	-	-	830	106	2	
	1.1	80	60	180	65	225	800	540	360	320	19	50	32	-	-	790	106	-	-	890	111	2	

Dimension and electrical data based on sizing definition following the instructions on page 96.

KDN 32-200 - 4 POLES - STANDARDISED CENTRIFUGAL ELECTRIC PUMPS FOR AIR CONDITIONING, REFRIGERATION, IRRIGATION, DECANTING, PRESSURISATION SYSTEMS, AND INDUSTRIAL APPLICATIONS

Pumped liquid temperature range: from -10 °C to +140 °C - Maximum ambient temperature: +40°C

= 1450 1/min

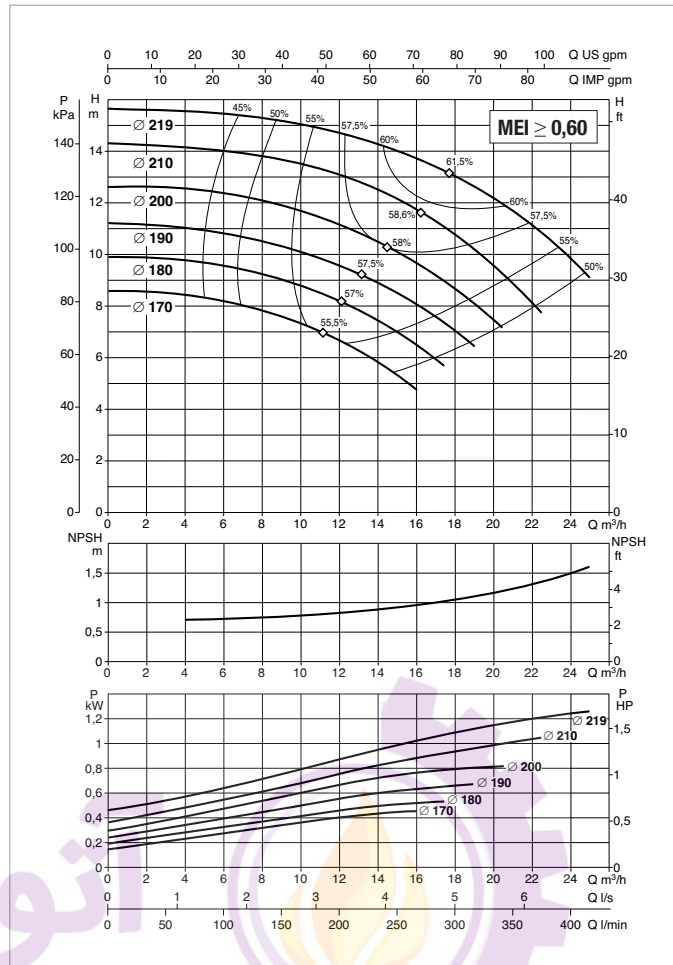
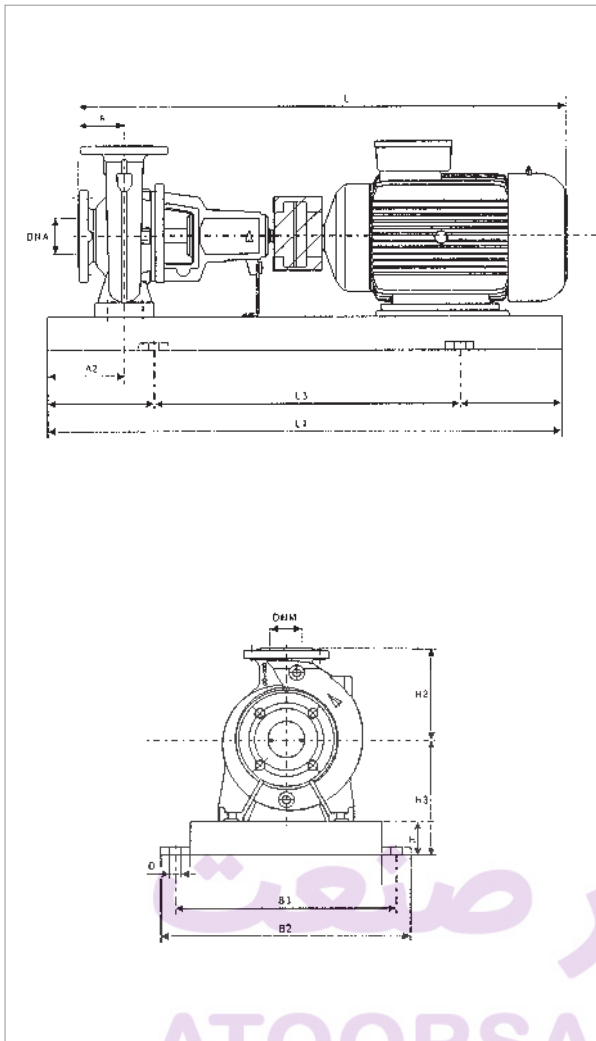

See hydraulic efficiency details on page 291.

The performance curves are based on kinematic viscosity values = 1 mm²/s and density equal to 1000 kg/m³. Curve tolerance according to ISO 9906.

MODEL	ELECTRICAL DATA					
	POWER (kW) 4 POLES	MOTOR SIZE	POWER INPUT 50 Hz	In A		MOTOR TYPE
				-	IE2	
KDN 32-200	0.37	MEC 71	3 x 230 - 400 V ~	1.7/0.975	-	-
	0.55	MEC 80	3 x 230 - 400 V ~	2.6/1.5	-	-
	0.75	MEC 80	3 x 230 - 400 V ~	-	3.57/2.08	IE2
	1.1	MEC 90S	3 x 230 - 400 V ~	-	4.68/2.8	IE2
	1.5	MEC 90L	3 x 230 - 400 V ~	-	6.24/3.6	IE2
	2.2	MEC 100L	3 x 230 - 400 V ~	-	8.75/5.05	IE2

MODEL	POWER (kW)	UNIT DIMENSIONS (mm)										FLANGE DIMENSIONS (mm)		STANDARD COUPLING				SPACER COUPLING				REF.
		A	A2	H2	H	H3	L1	L3	B2	B3	D	DNA	DNM	-		IE2		-		IE2		
		L	WEIGHT kg	L	WEIGHT kg	L	WEIGHT kg	L	WEIGHT kg	L	WEIGHT kg	L	WEIGHT kg									
KDN 32-200	0.37	80	60	180	65	225	800	540	360	320	19	50	32	730	87	-	-	830	92	-	-	2
	0.55	80	60	180	65	225	800	540	360	320	19	50	32	730	89	-	-	830	94	-	-	2
	0.75	80	60	180	65	225	800	540	360	320	19	50	32	-	-	730	90	-	-	830	95	2
	1.1	80	60	180	65	225	800	540	360	320	19	50	32	-	-	790	101	-	-	890	106	2
	1.5	80	60	180	65	225	900	600	390	350	19	50	32	-	-	830	101	-	-	930	106	3
	2.2	80	60	180	65	225	900	600	390	350	19	50	32	-	-	830	102	-	-	930	107	3

Dimension and electrical data based on sizing definition following the instructions on page 96.

KDN 40-125 - 4 POLES - STANDARDISED CENTRIFUGAL ELECTRIC PUMPS FOR AIR CONDITIONING, REFRIGERATION, IRRIGATION, DECANTING, PRESSURISATION SYSTEMS, AND INDUSTRIAL APPLICATIONS

Pumped liquid temperature range: from -10 °C to +140 °C - Maximum ambient temperature: +40°C

= 1450 1/min

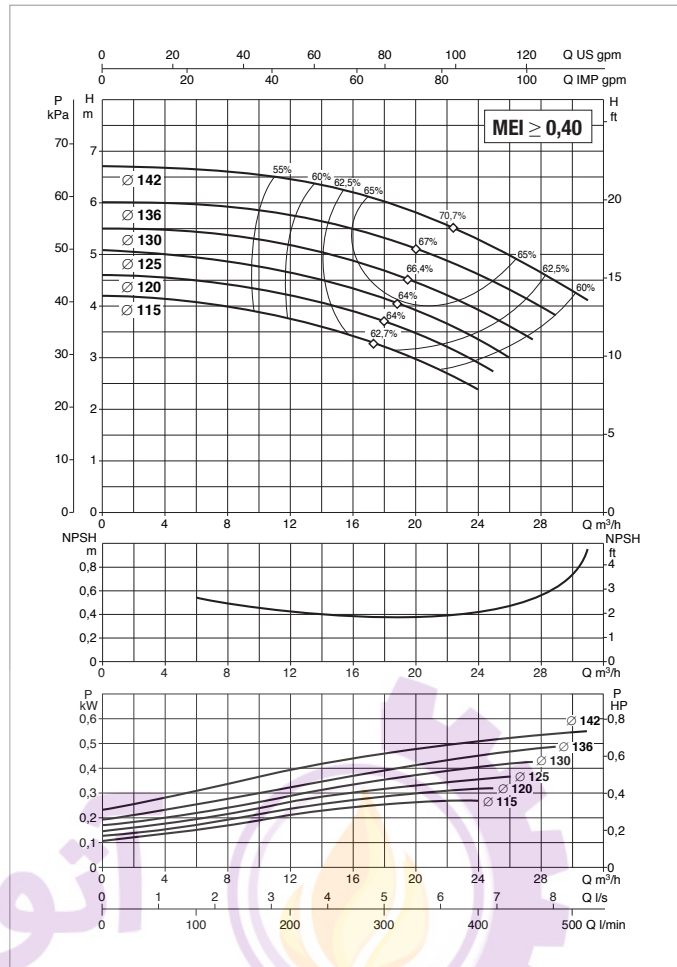
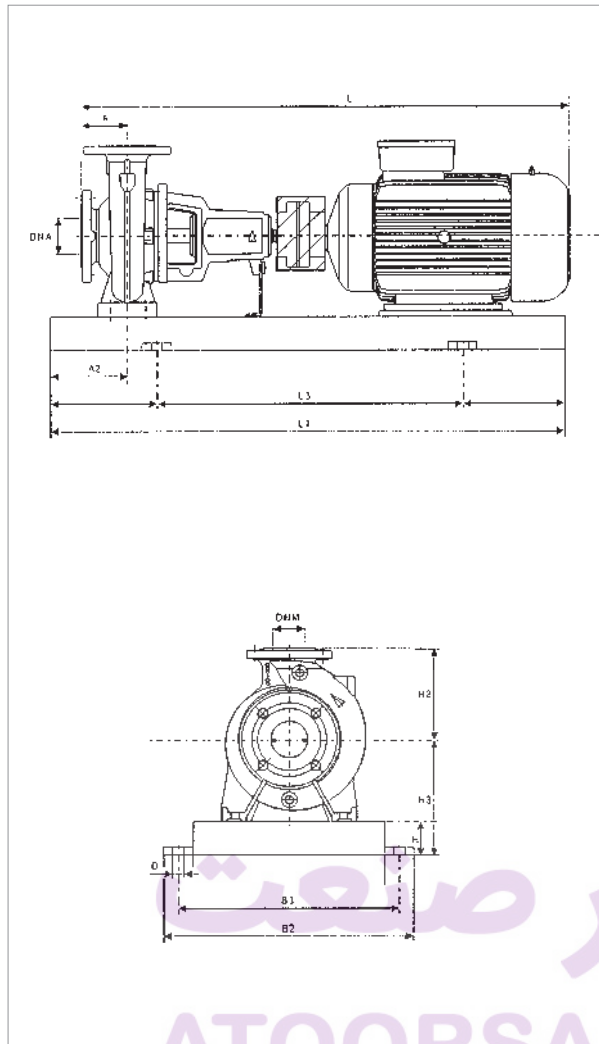

See hydraulic efficiency details on page 291.

The performance curves are based on kinematic viscosity values = 1 mm²/s and density equal to 1000 kg/m³. Curve tolerance according to ISO 9906.

MODEL	ELECTRICAL DATA					
	POWER (kW)	MOTOR SIZE	POWER INPUT 50 Hz	In A		MOTOR TYPE
	4 POLES			-	IE2	
KDN 40-125	0.37	MEC 71	3 x 230 - 400 V ~	1.7/0.975	-	-
	0.55	MEC 80	3 x 230 - 400 V ~	2.6/1.5	-	-
	0.75	MEC 80	3 x 230 - 400 V ~	-	3.57/2.10	IE2
	1.1	MEC 90S	3 x 230 - 400 V ~	-	4.68/2.9	IE2

MODEL	POWER (kW)	UNIT DIMENSIONS (mm)										FLANGE DIMENSIONS (mm)		STANDARD COUPLING				SPACER COUPLING				REF.
		A	A2	H2	H	H3	L1	L3	B2	B3	D	DNA	DNM	-		IE2		-		IE2		
		L	WEIGHT kg	L	WEIGHT kg	L	WEIGHT kg	L	WEIGHT kg													
KDN 40-125	0.37	80	60	140	65	177	800	540	360	320	19	65	40	730	81	-	-	830	86	-	-	2
	0.55	80	60	140	65	177	800	540	360	320	19	65	40	730	83	-	-	830	88	-	-	2
	0.75	80	60	140	65	177	800	540	360	320	19	65	40	-	-	730	84	-	-	830	89	2
	1.1	80	60	140	65	177	800	540	360	320	19	65	40	-	-	790	86	-	-	890	81	3

Dimension and electrical data based on sizing definition following the instructions on page 96.

KDN 40-160 - 4 POLES - STANDARDISED CENTRIFUGAL ELECTRIC PUMPS FOR AIR CONDITIONING, REFRIGERATION, IRRIGATION, DECANTING, PRESSURISATION SYSTEMS, AND INDUSTRIAL APPLICATIONS

Pumped liquid temperature range: from -10 °C to +140 °C - Maximum ambient temperature: +40°C

= 1450 1/min

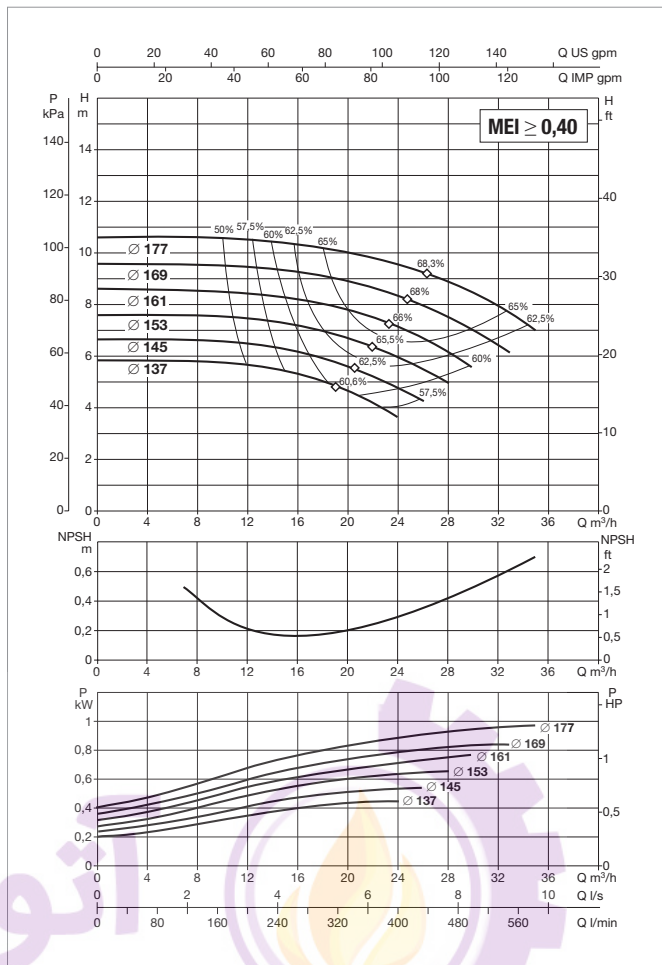
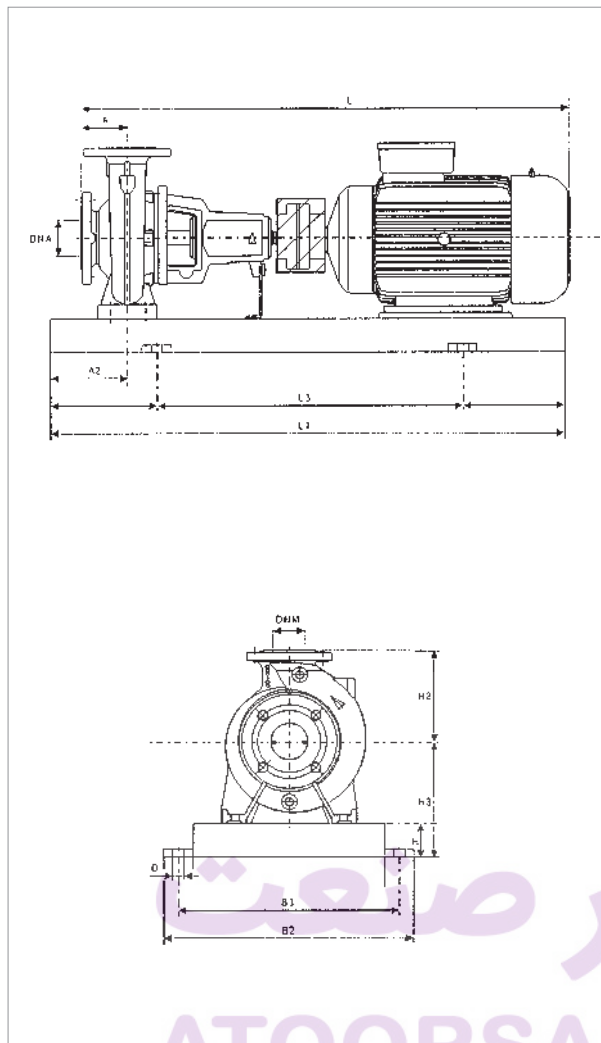

See hydraulic efficiency details on page 291.

The performance curves are based on kinematic viscosity values = 1 mm²/s and density equal to 1000 kg/m³. Curve tolerance according to ISO 9906.

MODEL	ELECTRICAL DATA					
	POWER (kW)	MOTOR SIZE	POWER INPUT 50 Hz	In A		MOTOR TYPE
	4 POLES			-	IE2	
KDN 40-160	0.37	MEC 71	3 x 230 - 400 V ~	1.7/0.975	-	-
	0.55	MEC 80	3 x 230 - 400 V ~	2.6/1.5	-	-
	0.75	MEC 80	3 x 230 - 400 V ~	-	3.57/2.11	IE2
	1.1	MEC 90S	3 x 230 - 400 V ~	-	4.68/2.10	IE2
	1.5	MEC 90L	3 x 230 - 400 V ~	-	6.24/3.7	IE2

MODEL	POWER (kW)	UNIT DIMENSIONS (mm)										FLANGE DIMENSIONS (mm)		STANDARD COUPLING				SPACER COUPLING				REF.
		A	A2	H2	H	H3	L1	L3	B2	B3	D	DNA	DNM	-		IE2		-		IE2		
		L	WEIGHT kg	L	WEIGHT kg	L	WEIGHT kg	L	WEIGHT kg	L	WEIGHT kg											
KDN 40-160	0.37	80	60	160	65	197	800	540	360	320	19	65	40	730	85	-	-	830	90	-	-	2
	0.55	80	60	160	65	197	800	540	360	320	19	65	40	730	89	-	-	830	94	-	-	2
	0.75	80	60	160	65	197	800	540	360	320	19	65	40	-	-	730	89	-	-	830	94	2
	1.1	80	60	160	65	197	800	540	360	320	19	65	40	-	-	790	91	-	-	890	96	2
	1.5	80	60	160	65	197	900	600	390	350	19	65	40	-	-	830	101	-	-	930	106	3

Dimension and electrical data based on sizing definition following the instructions on page 96.

KDN 40-200 - 4 POLES - STANDARDISED CENTRIFUGAL ELECTRIC PUMPS FOR AIR CONDITIONING, REFRIGERATION, IRRIGATION, DECANTING, PRESSURISATION SYSTEMS, AND INDUSTRIAL APPLICATIONS

Pumped liquid temperature range: from -10 °C to +140 °C - Maximum ambient temperature: +40°C

= 1450 1/min

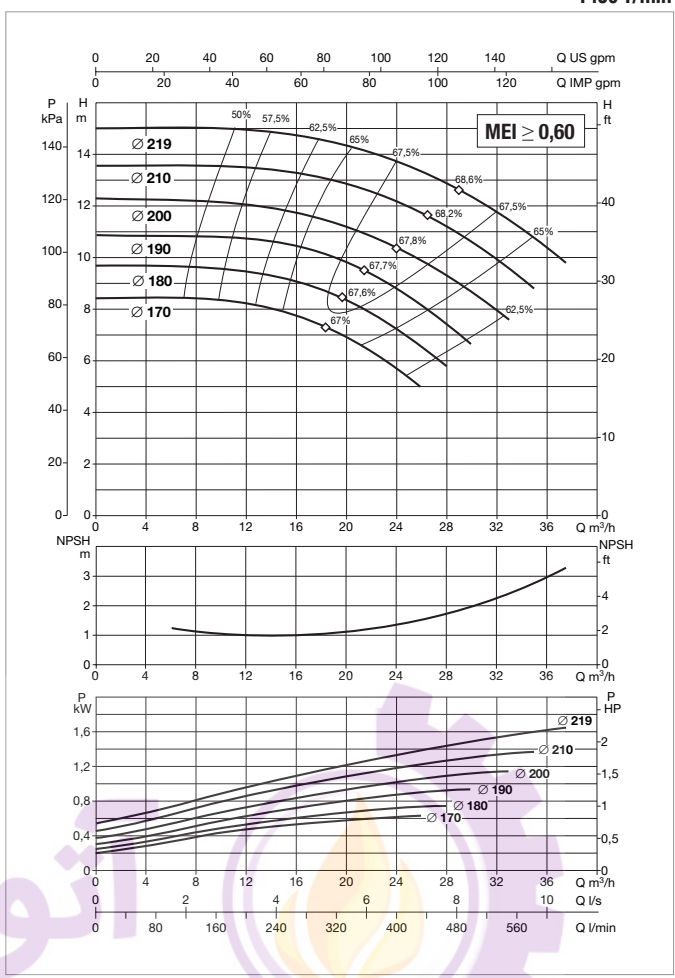
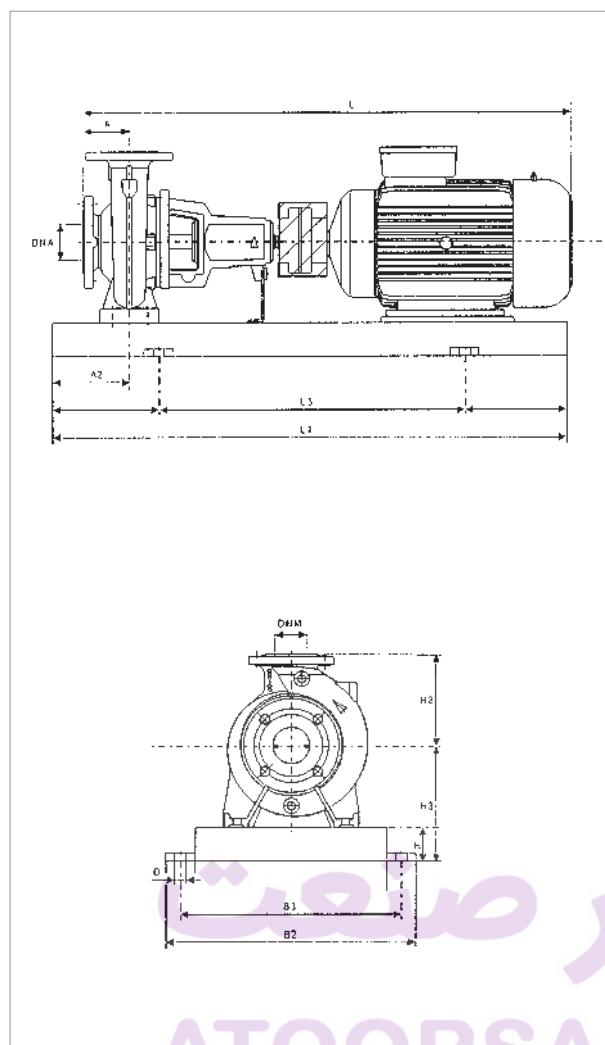

See hydraulic efficiency details on page 291.

The performance curves are based on kinematic viscosity values = 1 mm²/s and density equal to 1000 kg/m³. Curve tolerance according to ISO 9906.

MODEL	ELECTRICAL DATA					
	POWER (kW)	MOTOR SIZE	POWER INPUT 50 Hz	In A		MOTOR TYPE
	4 POLES			-	IE2	
KDN 40-200	0.55	MEC 80	3 x 230 - 400 V ~	2.6/1.5	-	-
	0.75	MEC 80	3 x 230 - 400 V ~	-	3.57/2.12	IE2
	1.1	MEC 90S	3 x 230 - 400 V ~	-	4.68/2.11	IE2
	1.5	MEC 90L	3 x 230 - 400 V ~	-	6.24/3.8	IE2
	2.2	MEC 100L	3 x 230 - 400 V ~	-	8.75/5.06	IE2
	3	MEC 100L	3 x 400 V - Δ	-	6.25	IE2

MODEL	POWER (kW)	UNIT DIMENSIONS (mm)										FLANGE DIMENSIONS (mm)		STANDARD COUPLING				SPACER COUPLING				REF.
		A	A2	H2	H	H3	L1	L3	B2	B3	D	DNA	DNM	-		IE2		-		IE2		
		L	WEIGHT kg	L	WEIGHT kg	L	WEIGHT kg	L	WEIGHT kg	L	WEIGHT kg	L	WEIGHT kg	L	WEIGHT kg	L	WEIGHT kg	L	WEIGHT kg			
KDN 40-200	0.55	100	60	180	65	225	900	600	390	350	19	65	40	750	98	-	-	850	103	-	-	3
	0.75	100	60	180	65	225	900	600	390	350	19	65	40	-	-	750	98	-	-	850	103	3
	1.1	100	60	180	65	225	900	600	390	350	19	65	40	-	-	810	101	-	-	910	106	3
	1.5	100	60	180	65	225	900	600	390	350	19	65	40	-	-	850	105	-	-	950	110	3
	2.2	100	60	180	65	225	900	600	390	350	19	65	40	-	-	850	111	-	-	950	116	3
	3	100	60	180	65	225	900	600	390	350	19	65	40	-	-	850	118	-	-	950	123	3

Dimension and electrical data based on sizing definition following the instructions on page 96.

KDN 40-250 - 4 POLES - STANDARDISED CENTRIFUGAL ELECTRIC PUMPS FOR AIR CONDITIONING, REFRIGERATION, IRRIGATION, DECANTING, PRESSURISATION SYSTEMS, AND INDUSTRIAL APPLICATIONS

Pumped liquid temperature range: from -10 °C to +140 °C - Maximum ambient temperature: +40°C

= 1450 1/min

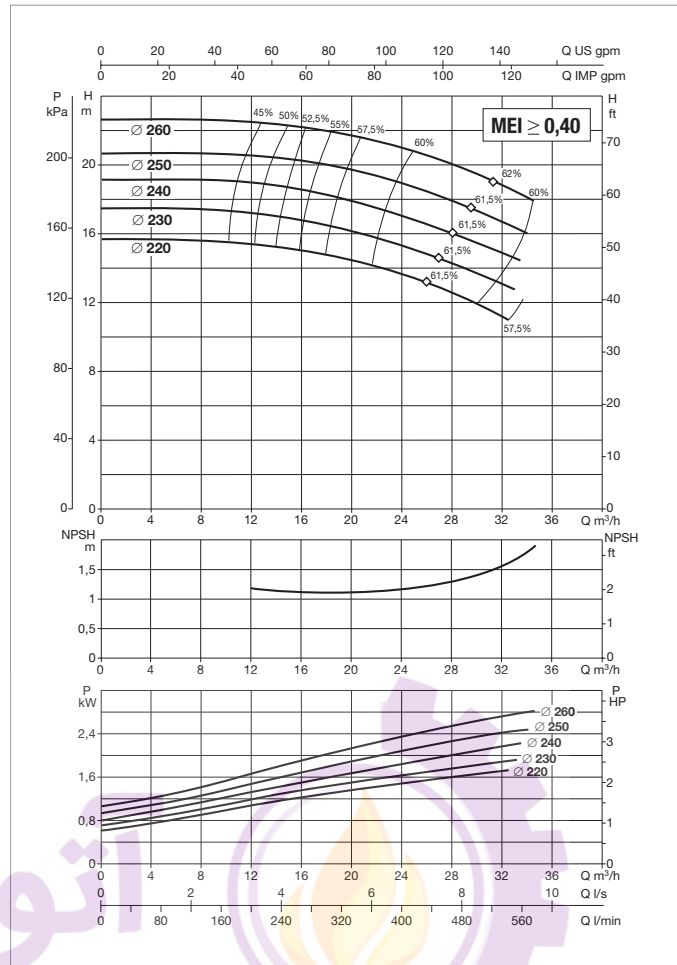
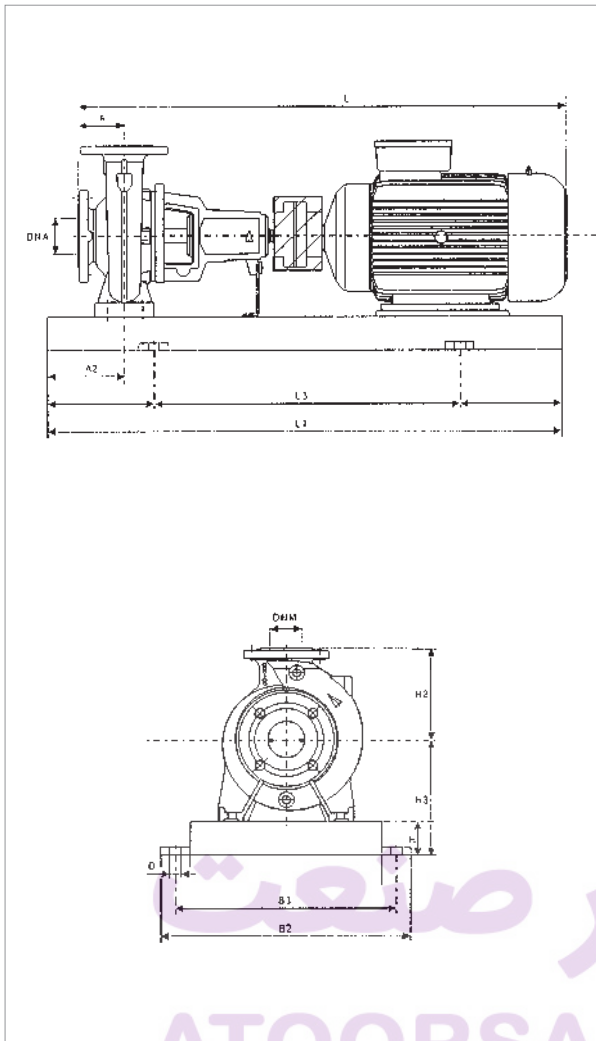

See hydraulic efficiency details on page 291.

The performance curves are based on kinematic viscosity values = 1 mm²/s and density equal to 1000 kg/m³. Curve tolerance according to ISO 9906.

MODEL	ELECTRICAL DATA					
	POWER (kW) 4 POLES	MOTOR SIZE	POWER INPUT 50 Hz	In A		MOTOR TYPE
				IE2	IE3	
KDN 40-250	1.5	MEC 90L	3 x 230 - 400 V ~	6.24/3.9	-	IE2
	2.2	MEC 100L	3 x 230 - 400 V ~	8.75/5.07	-	IE2
	3	MEC 100L	3 x 400 V - Δ	6.25	-	IE2
	4	MEC 112M	3 x 400 V - Δ	7.95	-	IE2

MODEL	POWER (kW)	UNIT DIMENSIONS (mm)										FLANGE DIMENSIONS (mm)		STANDARD COUPLING				SPACER COUPLING				REF.
		A	A2	H2	H	H3	L1	L3	B2	B3	D	DNA	DNM	IE2		IE3		IE2		IE3		
														L	WEIGHT kg	L	WEIGHT kg	L	WEIGHT kg	L	WEIGHT kg	
KDN 40-250	1.5	100	75	225	80	260	1000	660	450	400	24	65	40	850	125	-	-	950	130	-	-	4
	2.2	100	75	225	80	260	1000	660	450	400	24	65	40	850	129	-	-	950	134	-	-	4
	3	100	75	225	80	260	1000	660	450	400	24	65	40	850	149	-	-	950	154	-	-	4
	4	100	75	225	80	260	1000	660	450	400	24	65	40	935	200	-	-	1035	205	-	-	4

Dimension and electrical data based on sizing definition following the instructions on page 96.

KDN 50-125 - 4 POLES - STANDARDISED CENTRIFUGAL ELECTRIC PUMPS FOR AIR CONDITIONING, REFRIGERATION, IRRIGATION, DECANTING, PRESSURISATION SYSTEMS, AND INDUSTRIAL APPLICATIONS

Pumped liquid temperature range: from -10 °C to +140 °C - Maximum ambient temperature: +40°C

= 1450 1/min

CENTRIFUGAL PUMPS

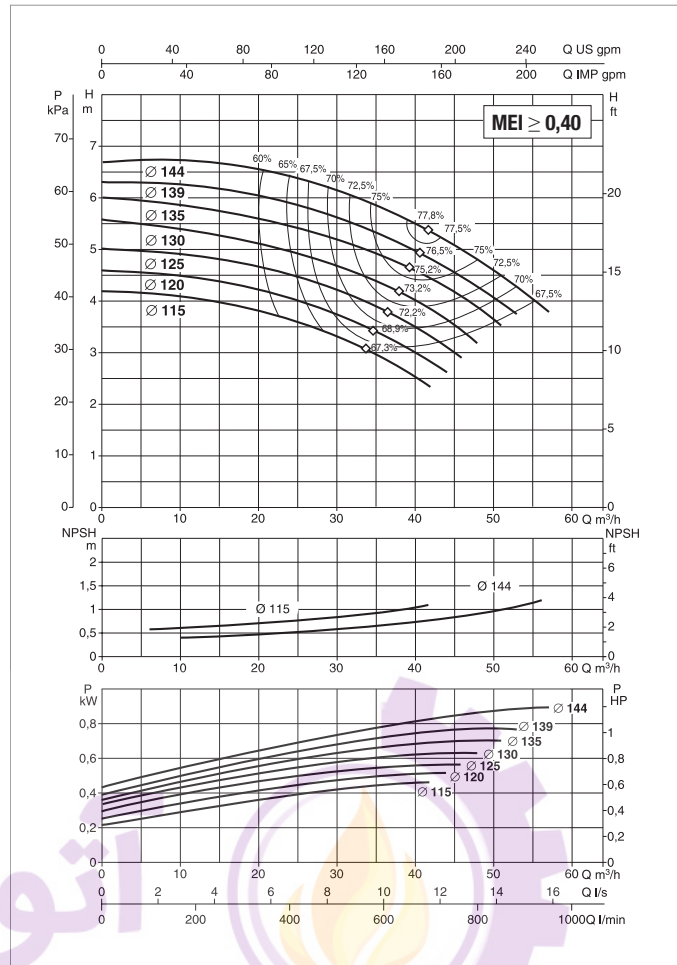
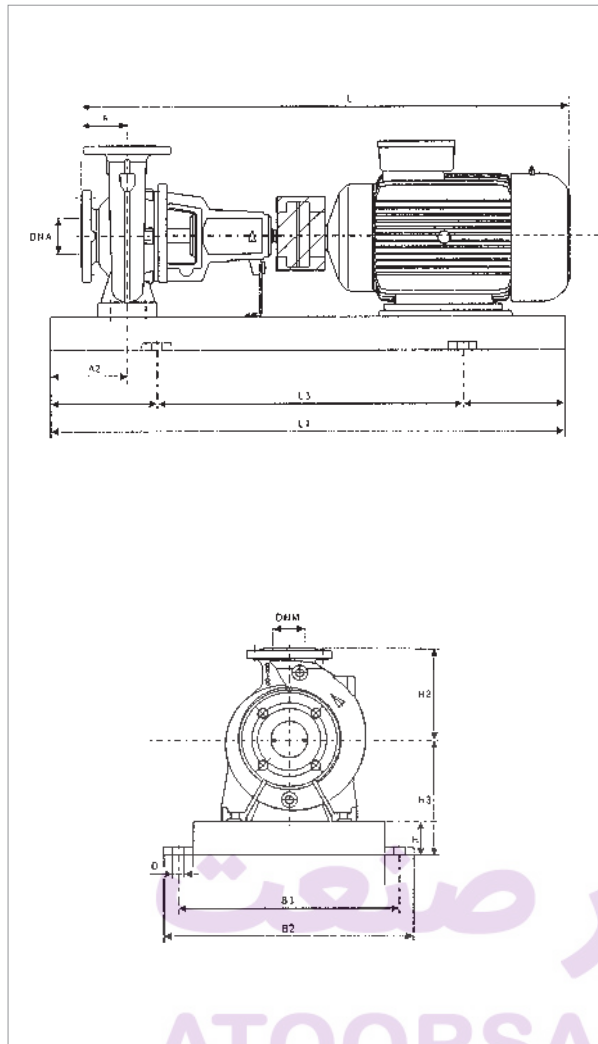

See hydraulic efficiency details on page 291.

The performance curves are based on kinematic viscosity values = 1 mm²/s and density equal to 1000 kg/m³. Curve tolerance according to ISO 9906.

MODEL	ELECTRICAL DATA					
	POWER (kW)	MOTOR SIZE	POWER INPUT 50 Hz	In A		MOTOR TYPE
	4 POLES			-	IE2	
KDN 50-125	0.37	MEC 71	3 x 230 - 400 V ~	1.7/0.975	-	-
	0.55	MEC 80	3 x 230 - 400 V ~	2.6/1.5	-	-
	0.75	MEC 80	3 x 230 - 400 V ~	-	3.57/2.13	IE2
	1.1	MEC 90S	3 x 230 - 400 V ~	-	4.68/2.12	IE2
	1.5	MEC 90L	3 x 230 - 400 V ~	-	6.24/3.10	IE2

MODEL	POWER (kW)	UNIT DIMENSIONS (mm)										FLANGE DIMENSIONS (mm)		STANDARD COUPLING				SPACER COUPLING				REF.
		A	A2	H2	H	H3	L1	L3	B2	B3	D	DNA	DNM	-		IE2		-		IE2		
		L	WEIGHT kg	L	WEIGHT kg	L	WEIGHT kg	L	WEIGHT kg													
KDN 50-125	0.37	100	60	160	65	197	800	540	360	320	19	65	50	750	87	-	-	850	92	-	-	2
	0.55	100	60	160	65	197	800	540	360	320	19	65	50	750	90	-	-	850	95	-	-	2
	0.75	100	60	160	65	197	800	540	360	320	19	65	50	-	-	750	91	-	-	850	96	2
	1.1	100	60	160	65	197	800	540	360	320	19	65	50	-	-	810	93	-	-	910	98	2
	1.5	100	60	160	65	197	900	600	390	350	19	65	50	-	-	850	101	-	-	950	106	3

Dimension and electrical data based on sizing definition following the instructions on page 96.

KDN 50-160 - 4 POLES - STANDARDISED CENTRIFUGAL ELECTRIC PUMPS FOR AIR CONDITIONING, REFRIGERATION, IRRIGATION, DECANTING, PRESSURISATION SYSTEMS, AND INDUSTRIAL APPLICATIONS

Pumped liquid temperature range: from -10 °C to +140 °C - Maximum ambient temperature: +40°C

= 1450 1/min

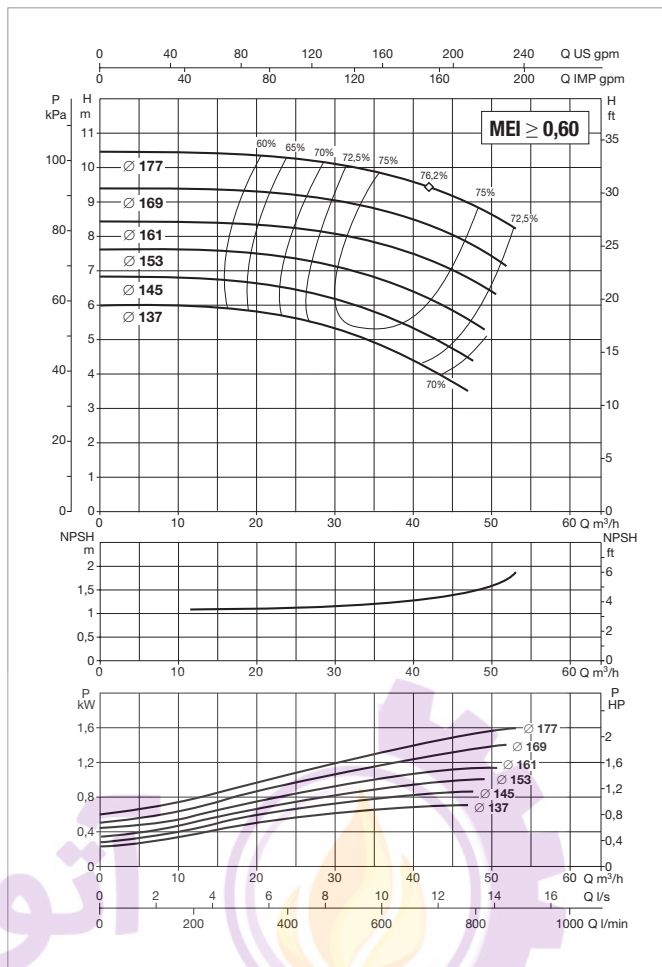
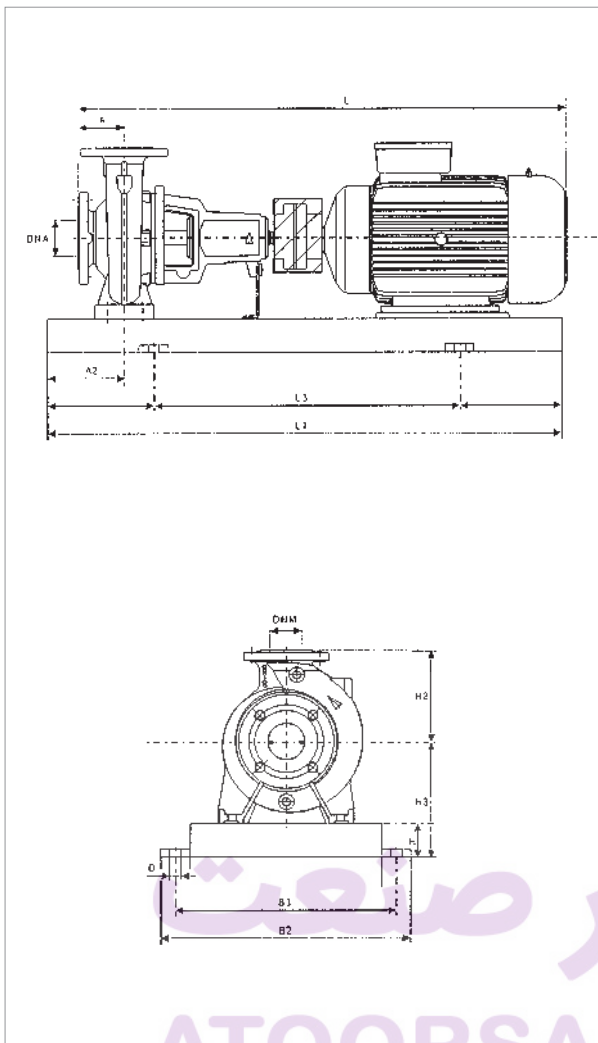

See hydraulic efficiency details on page 291.

The performance curves are based on kinematic viscosity values = 1 mm²/s and density equal to 1000 kg/m³. Curve tolerance according to ISO 9906.

MODEL	ELECTRICAL DATA					
	POWER (kW)	MOTOR SIZE	POWER INPUT 50 Hz	In A		MOTOR TYPE
	4 POLES			-	IE2	
KDN 50-160	0.55	MEC 80	3 x 230 - 400 V ~	2.6/1.5	-	-
	0.75	MEC 80	3 x 230 - 400 V ~	-	3.57/2.14	IE2
	1.1	MEC 90S	3 x 230 - 400 V ~	-	4.68/2.13	IE2
	1.5	MEC 90L	3 x 230 - 400 V ~	-	6.24/3.11	IE2
	2.2	MEC 100L	3 x 230 - 400 V ~	-	8.75/5.08	IE2
	3	MEC 100L	3 x 400 V - Δ	-	6.25	IE2

MODEL	POWER (kW)	UNIT DIMENSIONS (mm)										FLANGE DIMENSIONS (mm)		STANDARD COUPLING				SPACER COUPLING				REF.
		A	A2	H2	H	H3	L1	L3	B2	B3	D	DNA	DNM	-		IE2		-		IE2		
		L	WEIGHT kg	L	WEIGHT kg	L	WEIGHT kg	L	WEIGHT kg	L	WEIGHT kg	L	WEIGHT kg	L	WEIGHT kg	L	WEIGHT kg	L	WEIGHT kg			
KDN 50-160	0.55	100	60	180	65	225	900	600	390	350	19	65	50	750	97	-	-	850	102	-	-	3
	0.75	100	60	180	65	225	900	600	390	350	19	65	50	-	-	750	98	-	-	850	103	3
	1.1	100	60	180	65	225	900	600	390	350	19	65	50	-	-	810	100	-	-	910	105	3
	1.5	100	60	180	65	225	900	600	390	350	19	65	50	-	-	850	103	-	-	950	108	3
	2.2	100	60	180	65	225	900	600	390	350	19	65	50	-	-	850	107	-	-	950	112	3
	3	100	60	180	65	225	900	600	390	350	19	65	50	-	-	850	110	-	-	950	115	3

Dimension and electrical data based on sizing definition following the instructions on page 96.

KDN 50-200 - 4 POLES - STANDARDISED CENTRIFUGAL ELECTRIC PUMPS FOR AIR CONDITIONING, REFRIGERATION, IRRIGATION, DECANTING, PRESSURISATION SYSTEMS, AND INDUSTRIAL APPLICATIONS

Pumped liquid temperature range: from -10 °C to +140 °C - Maximum ambient temperature: +40°C

= 1450 1/min

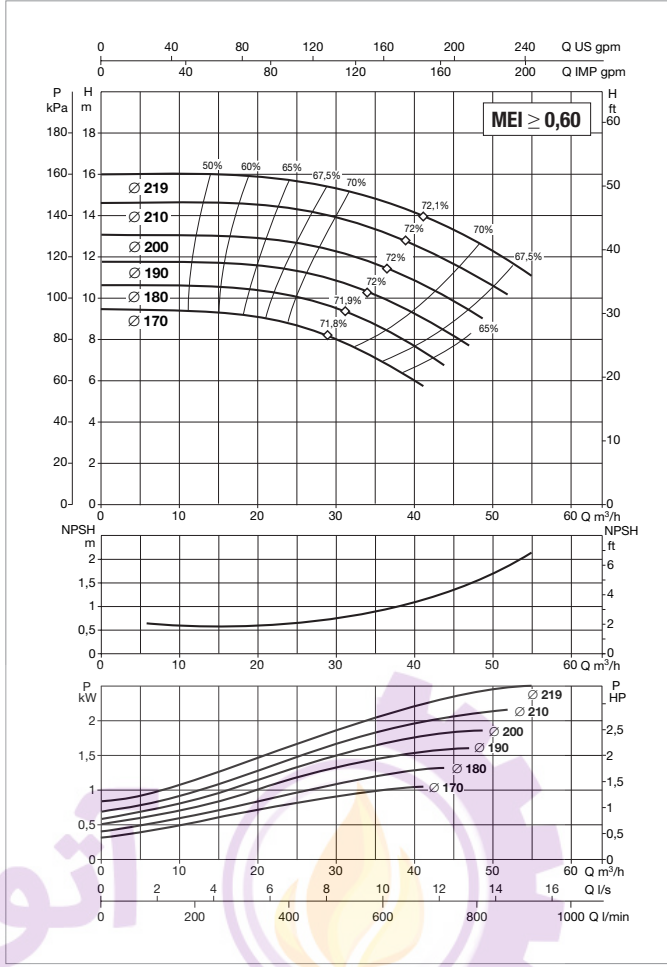
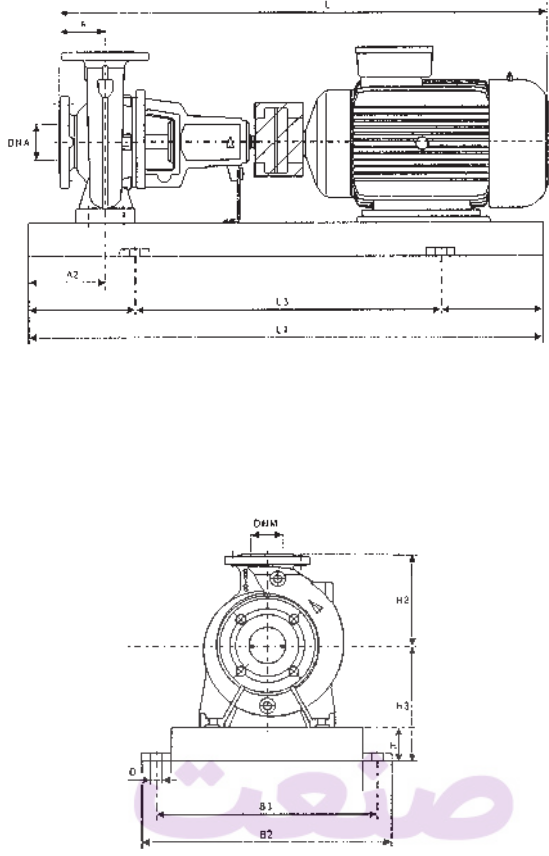

See hydraulic efficiency details on page 291.

The performance curves are based on kinematic viscosity values = 1 mm²/s and density equal to 1000 kg/m³. Curve tolerance according to ISO 9906.

MODEL	ELECTRICAL DATA					
	POWER (kW) 4 POLES	MOTOR SIZE	POWER INPUT 50 Hz	In A		MOTOR TYPE
				IE2	IE3	
KDN 50-200	0.75	MEC 80	3 x 230 - 400 V ~	3.57/2.15	-	IE2
	1.1	MEC 90S	3 x 230 - 400 V ~	4.68/2.14	-	IE2
	1.5	MEC 90L	3 x 230 - 400 V ~	6.24/3.12	-	IE2
	2.2	MEC 100L	3 x 230 - 400 V ~	8.75/5.09	-	IE2
	3	MEC 100L	3 x 400 V - Δ	6.25	-	IE2
	4	MEC 112M	3 x 400 V - Δ	7.95	-	IE2

MODEL	POWER (kW)	UNIT DIMENSIONS (mm)										FLANGE DIMENSIONS (mm)		STANDARD COUPLING				SPACER COUPLING				REF.
		A	A2	H2	H	H3	L1	L3	B2	B3	D	DNA	DNM	IE2		IE3		IE2		IE3		
														L	WEIGHT kg	L	WEIGHT kg	L	WEIGHT kg	L	WEIGHT kg	
KDN 50-200	0.75	100	60	200	65	225	900	600	390	350	19	65	50	750	104	-	-	850	109	-	-	3
	1.1	100	60	200	65	225	900	600	390	350	19	65	50	810	107	-	-	910	112	-	-	3
	1.5	100	60	200	65	225	900	600	390	350	19	65	50	850	114	-	-	950	119	-	-	3
	2.2	100	60	200	65	225	900	600	390	350	19	65	50	850	123	-	-	950	128	-	-	3
	3	100	60	200	65	225	900	600	390	350	19	65	50	850	122	-	-	950	127	-	-	3
	4	100	60	200	65	225	900	600	390	350	19	65	50	935	122	-	-	1035	127	-	-	3

Dimension and electrical data based on sizing definition following the instructions on page 96.

KDN 50-250 - 4 POLES - STANDARDISED CENTRIFUGAL ELECTRIC PUMPS FOR AIR CONDITIONING, REFRIGERATION, IRRIGATION, DECANTING, PRESSURISATION SYSTEMS, AND INDUSTRIAL APPLICATIONS

Pumped liquid temperature range: from -10 °C to +140 °C - Maximum ambient temperature: +40°C

= 1450 1/min

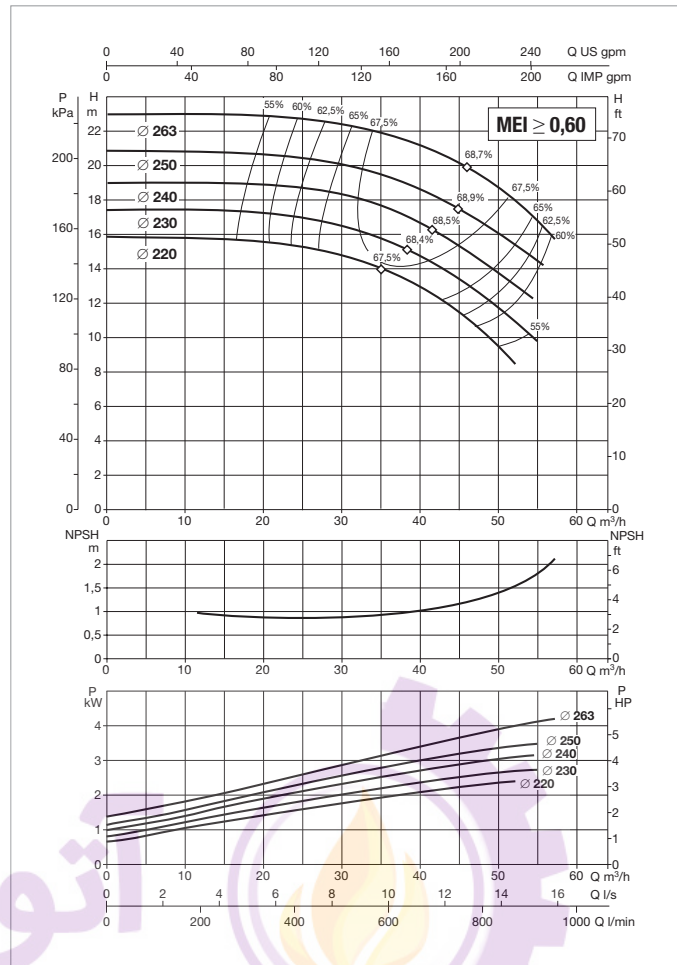
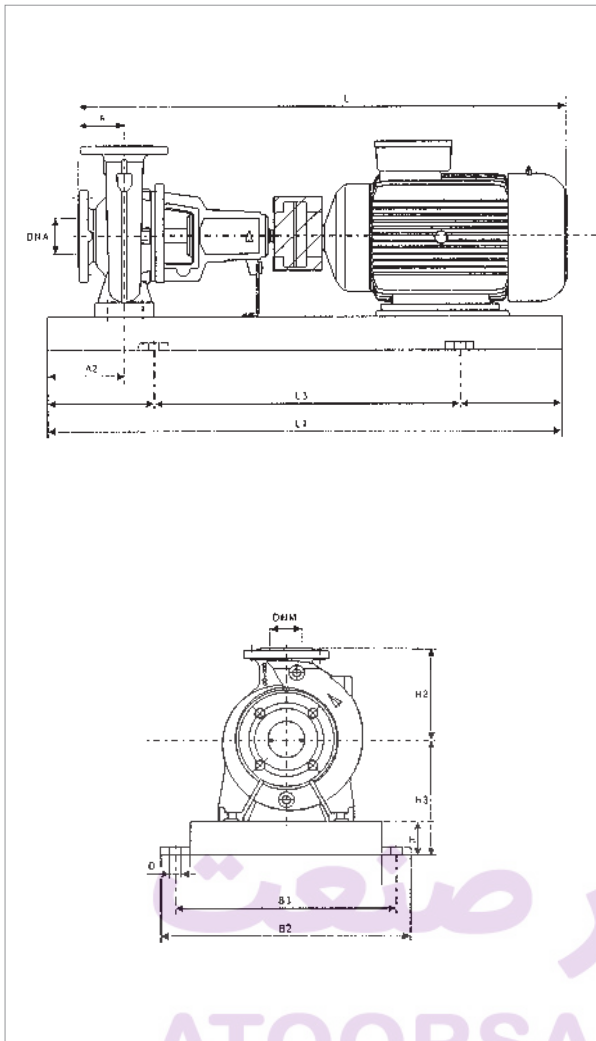

See hydraulic efficiency details on page 291.

The performance curves are based on kinematic viscosity values = 1 mm²/s and density equal to 1000 kg/m³. Curve tolerance according to ISO 9906.

MODEL	ELECTRICAL DATA					
	POWER (kW)	MOTOR SIZE	POWER INPUT 50 Hz	In A		MOTOR TYPE
	4 POLES			IE2	IE3	
KDN 50-250	2.2	MEC 100L	3 x 230 - 400 V ~	8.75/5.11	-	IE2
	3	MEC 100L	3 x 400 V - Δ	6.25	-	IE2
	4	MEC 112M	3 x 400 V - Δ	7.95	-	IE2
	5.5	MEC 132S	3 x 400 V - Δ	10.6	-	IE2

MODEL	POWER (kW)	UNIT DIMENSIONS (mm)										FLANGE DIMENSIONS (mm)		STANDARD COUPLING				SPACER COUPLING				REF.
		A	A2	H2	H	H3	L1	L3	B2	B3	D	DNA	DNM	IE2		IE3		IE2		IE3		
		L	WEIGHT kg	L	WEIGHT kg	L	WEIGHT kg	L	WEIGHT kg	L	WEIGHT kg											
KDN 50-250	2.2	100	75	225	80	260	1000	660	450	400	24	65	50	850	135	-	-	950	140	-	-	4
	3	100	75	225	80	260	1000	660	450	400	24	65	50	850	138	-	-	950	143	-	-	4
	4	100	75	225	80	260	1000	660	450	400	24	65	50	935	165	-	-	1035	170	-	-	4
	5.5	100	75	225	80	260	1120	740	490	440	24	65	50	935	173	-	-	1035	178	-	-	5

Dimension and electrical data based on sizing definition following the instructions on page 96.

KDN 65-125 - 4 POLES - STANDARDISED CENTRIFUGAL ELECTRIC PUMPS FOR AIR CONDITIONING, REFRIGERATION, IRRIGATION, DECANTING, PRESSURISATION SYSTEMS, AND INDUSTRIAL APPLICATIONS

Pumped liquid temperature range: from -10 °C to +140 °C - Maximum ambient temperature: +40°C

= 1450 1/min

CENTRIFUGAL PUMPS

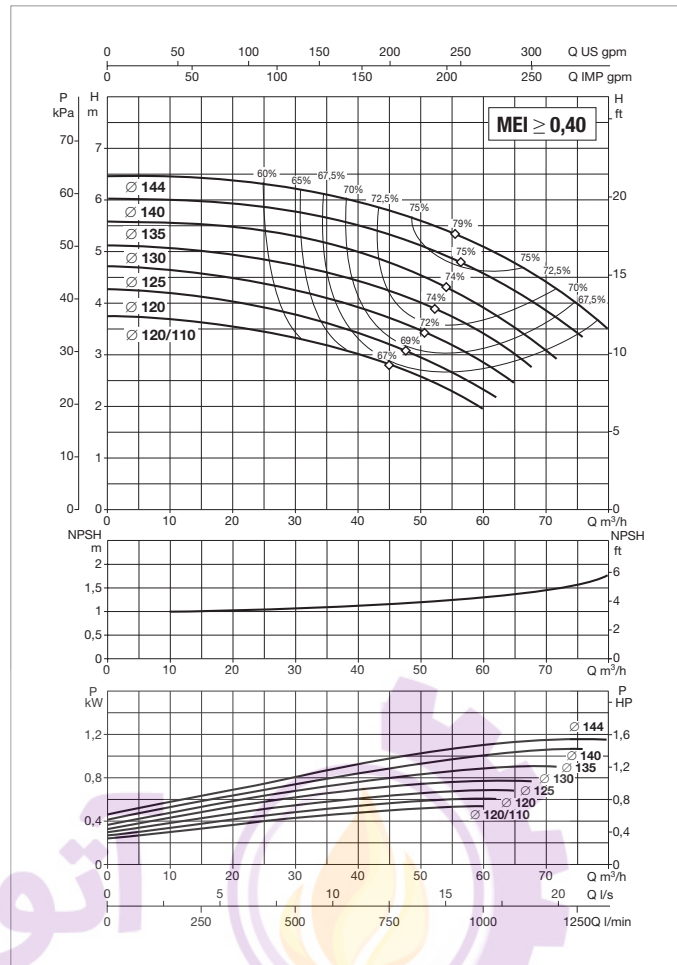
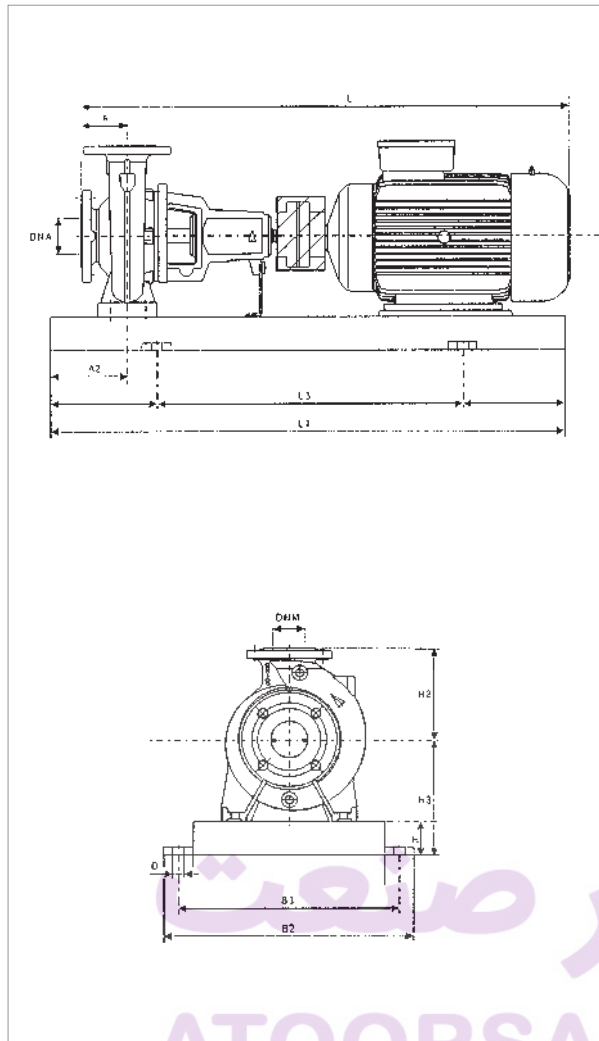

See hydraulic efficiency details on page 291.

The performance curves are based on kinematic viscosity values = 1 mm²/s and density equal to 1000 kg/m³. Curve tolerance according to ISO 9906.

MODEL	ELECTRICAL DATA					
	POWER (kW) 4 POLES	MOTOR SIZE	POWER INPUT 50 Hz	In A		MOTOR TYPE
				-	IE2	
KDN 65-125	0.37	MEC 71	3 x 230 - 400 V ~	1.7/0.975	-	-
	0.55	MEC 80	3 x 230 - 400 V ~	-	2.6/1.5	IE2
	0.75	MEC 80	3 x 230 - 400 V ~	-	3.57/2.16	IE2
	1.1	MEC 90S	3 x 230 - 400 V ~	-	4.68/2.15	IE2
	1.5	MEC 90L	3 x 230 - 400 V ~	-	6.24/3.13	IE2
	2.2	MEC 100L	3 x 230 - 400 V ~	-	8.75/5.12	IE2

MODEL	POWER (kW)	UNIT DIMENSIONS (mm)										FLANGE DIMENSIONS (mm)		STANDARD COUPLING				SPACER COUPLING				REF.
		A	A2	H2	H	H3	L1	L3	B2	B3	D	DNA	DNM	-		IE2		-		IE2		
														L	WEIGHT kg	L	WEIGHT kg	L	WEIGHT kg	L	WEIGHT kg	
KDN 65-125	0.37	100	60	180	65	225	900	600	390	350	19	80	50	714	94	-	-	814	99	-	-	3
	0.55	100	60	180	65	225	900	600	390	350	19	80	50	-	-	757	97	-	-	857	102	3
	0.75	100	60	180	65	225	900	600	390	350	19	80	50	-	-	750	98	-	-	850	103	3
	1.1	100	60	180	65	225	900	600	390	350	19	80	50	-	-	810	100	-	-	910	105	3
	1.5	100	60	180	65	225	900	600	390	350	19	80	50	-	-	850	103	-	-	950	108	3
	2.2	100	60	180	65	225	900	600	390	350	19	80	50	-	-	850	107	-	-	950	112	3

Dimension and electrical data based on sizing definition following the instructions on page 96.

KDN 65-160 - 4 POLES - STANDARDISED CENTRIFUGAL ELECTRIC PUMPS FOR AIR CONDITIONING, REFRIGERATION, IRRIGATION, DECANTING, PRESSURISATION SYSTEMS, AND INDUSTRIAL APPLICATIONS

Pumped liquid temperature range: from -10 °C to +140 °C - Maximum ambient temperature: +40°C

= 1450 1/min

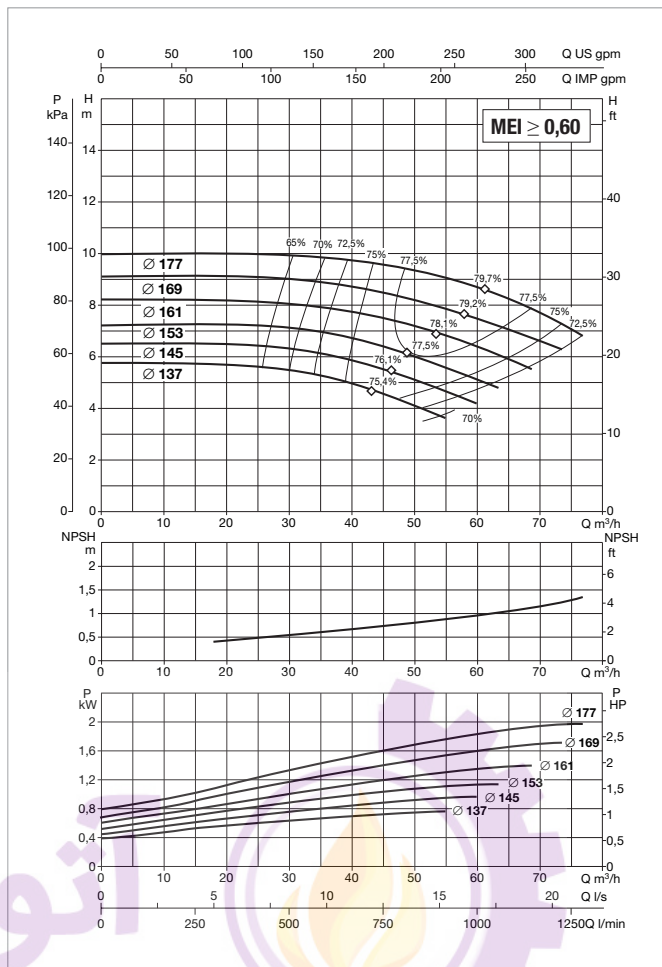
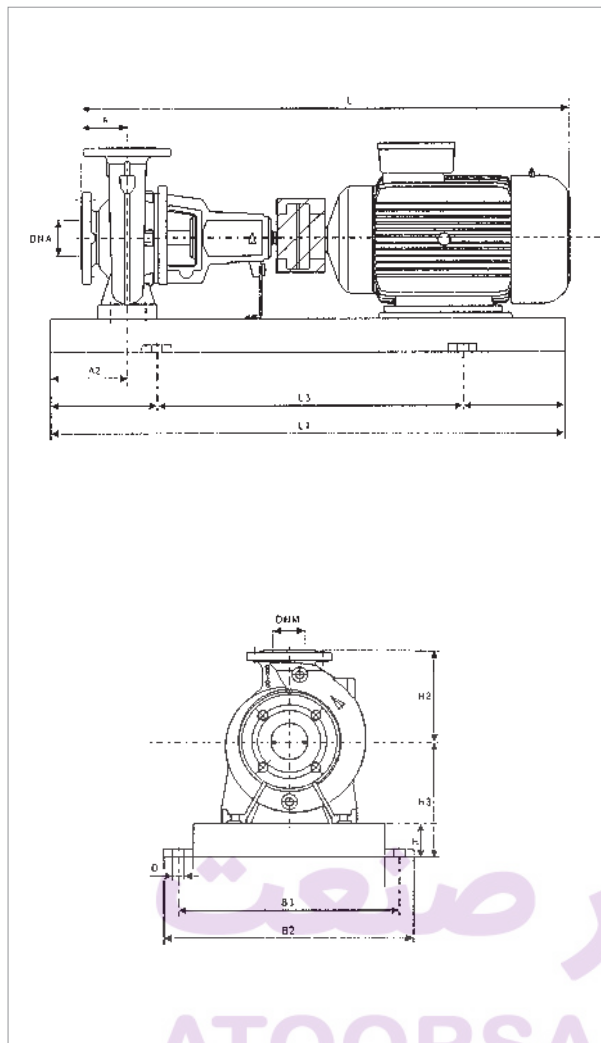

See hydraulic efficiency details on page 291.

The performance curves are based on kinematic viscosity values = 1 mm²/s and density equal to 1000 kg/m³. Curve tolerance according to ISO 9906.

MODEL	ELECTRICAL DATA					
	POWER (kW)	MOTOR SIZE	POWER INPUT 50 Hz	In A		MOTOR TYPE
	4 POLES			IE2	IE3	
KDN 65-160	0.75	MEC 80	3 x 230 - 400 V ~	3.57/2.17	-	IE2
	1.1	MEC 90S	3 x 230 - 400 V ~	4.68/2.17	-	IE2
	1.5	MEC 90L	3 x 230 - 400 V ~	6.24/3.14	-	IE2
	2.2	MEC 100L	3 x 230 - 400 V ~	8.75/5.13	-	IE2
	3	MEC 100L	3 x 400 V - Δ	6.25	-	IE2

MODEL	POWER (kW)	UNIT DIMENSIONS (mm)										FLANGE DIMENSIONS (mm)		STANDARD COUPLING				SPACER COUPLING				REF.
		A	A2	H2	H	H3	L1	L3	B2	B3	D	DNA	DNM	IE2		IE3		IE2		IE3		
														L	WEIGHT kg	L	WEIGHT kg	L	WEIGHT kg	L	WEIGHT kg	
KDN 65-160	0.75	100	60	200	65	225	900	600	390	350	19	80	65	750	101	-	-	850	106	-	-	3
	1.1	100	60	200	65	225	900	600	390	350	19	80	65	810	103	-	-	910	108	-	-	3
	1.5	100	60	200	65	225	900	600	390	350	19	80	65	850	114	-	-	950	119	-	-	3
	2.2	100	60	200	65	225	900	600	390	350	19	80	65	850	114	-	-	950	119	-	-	3
	3	100	60	200	65	225	900	600	390	350	19	80	65	850	148	-	-	950	153	-	-	3

Dimension and electrical data based on sizing definition following the instructions on page 96.

KDN 65-200 - 4 POLES - STANDARDISED CENTRIFUGAL ELECTRIC PUMPS FOR AIR CONDITIONING, REFRIGERATION, IRRIGATION, DECANTING, PRESSURISATION SYSTEMS, AND INDUSTRIAL APPLICATIONS

Pumped liquid temperature range: from -10 °C to +140 °C - Maximum ambient temperature: +40°C

= 1450 1/min

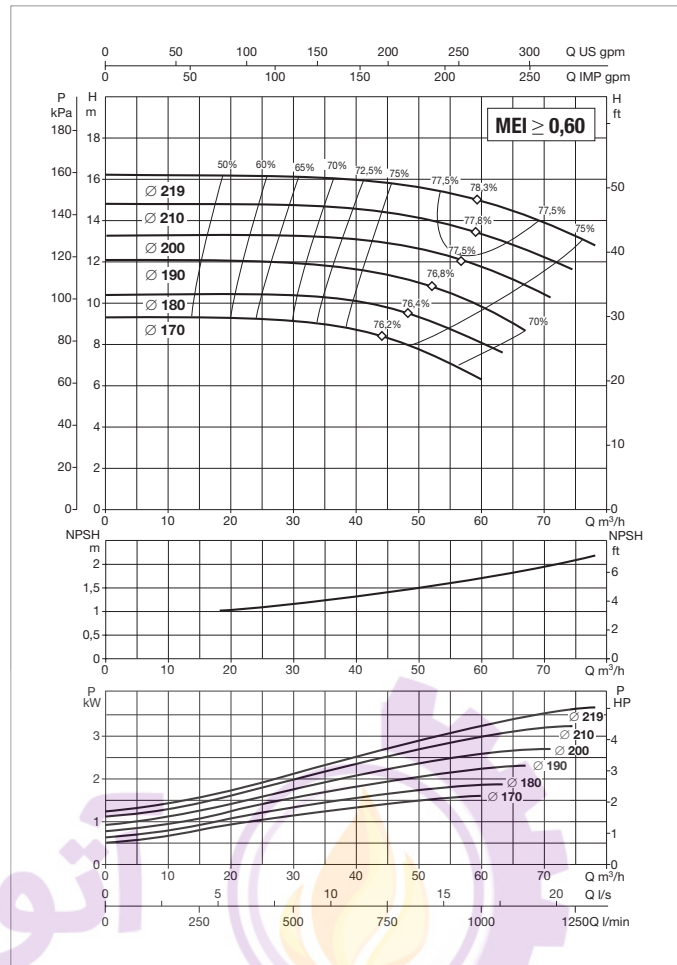
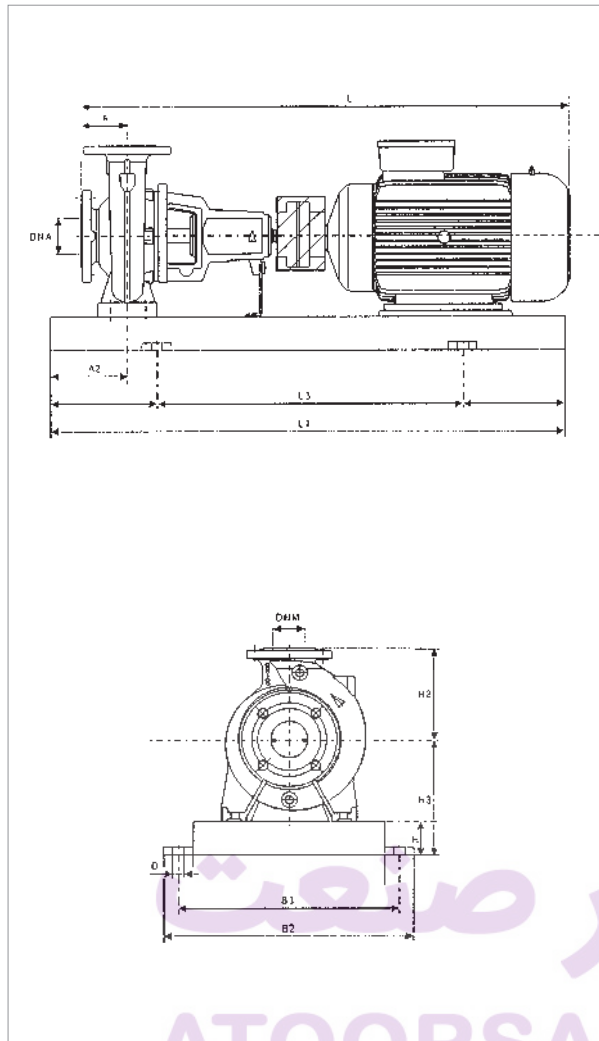

See hydraulic efficiency details on page 291.

The performance curves are based on kinematic viscosity values = 1 mm²/s and density equal to 1000 kg/m³. Curve tolerance according to ISO 9906.

MODEL	ELECTRICAL DATA					
	POWER (kW) 4 POLES	MOTOR SIZE	POWER INPUT 50 Hz	In A		MOTOR TYPE
				IE2	IE3	
KDN 65-200	1.1	MEC 90S	3 x 230 - 400 V ~	4.68/2.18	-	IE2
	1.5	MEC 90L	3 x 230 - 400 V ~	6.24/3.15	-	IE2
	2.2	MEC 100L	3 x 230 - 400 V ~	8.75/5.14	-	IE2
	3	MEC 100L	3 x 400 V - Δ	6.25	-	IE2
	4	MEC 112M	3 x 400 V - Δ	7.95	-	IE2
	5.5	MEC 132S	3 x 400 V - Δ	10.6	-	IE2

MODEL	POWER (kW)	UNIT DIMENSIONS (mm)									FLANGE DIMENSIONS (mm)		STANDARD COUPLING				SPACER COUPLING				REF.	
		A	A2	H2	H	H3	L1	L3	B2	B3	D	DNA	DNM	IE2		IE3		IE2		IE3		
														L	WEIGHT kg	L	WEIGHT kg	L	WEIGHT kg	L		WEIGHT kg
KDN 65-200	1.1	100	75	225	80	260	1000	660	450	400	24	80	65	810	141	-	-	950	146	-	-	4
	1.5	100	75	225	80	260	1000	660	450	400	24	80	65	850	143	-	-	990	148	-	-	4
	2.2	100	75	225	80	260	1120	740	490	440	24	80	65	850	147	-	-	990	152	-	-	5
	3	100	75	225	80	260	1120	740	490	440	24	80	65	850	150	-	-	990	155	-	-	5
	4	100	75	225	80	260	1120	740	490	440	24	80	65	935	150	-	-	1075	155	-	-	5
	5.5	100	75	225	80	260	1120	740	490	440	24	80	65	935	200	-	-	1075	205	-	-	5

Dimension and electrical data based on sizing definition following the instructions on page 96.

KDN 65-250 - 4 POLES - STANDARDISED CENTRIFUGAL ELECTRIC PUMPS FOR AIR CONDITIONING, REFRIGERATION, IRRIGATION, DECANTING, PRESSURISATION SYSTEMS, AND INDUSTRIAL APPLICATIONS

Pumped liquid temperature range: from -10 °C to +140 °C - Maximum ambient temperature: +40°C

= 1450 1/min

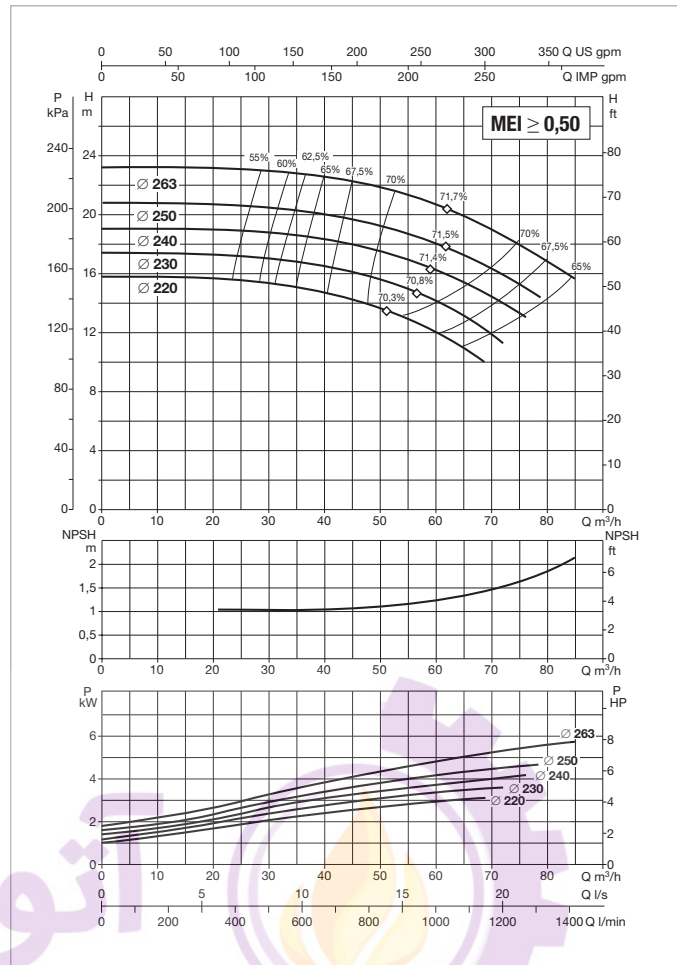
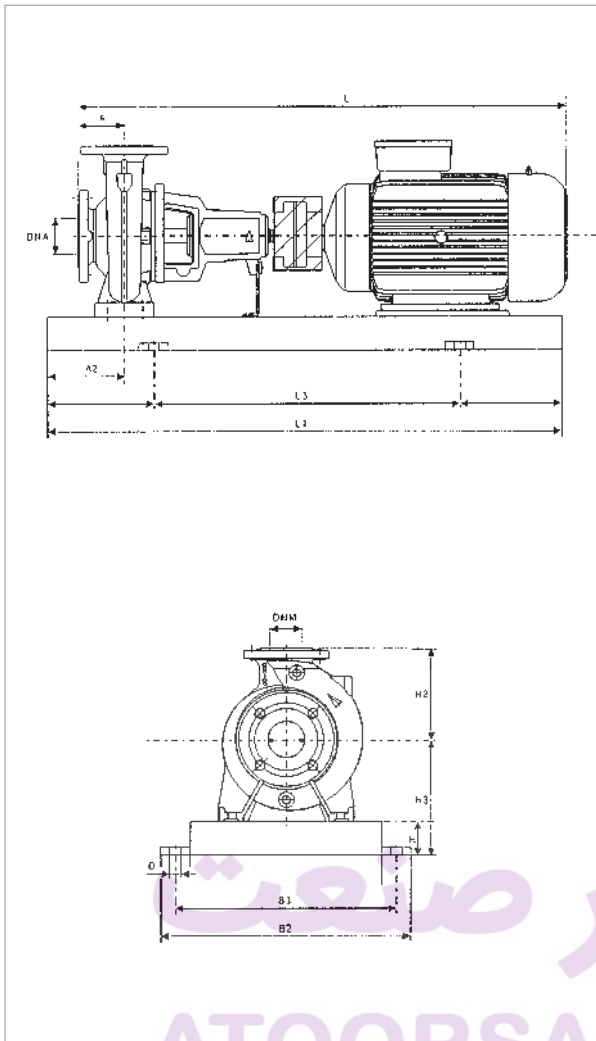

See hydraulic efficiency details on page 291.

The performance curves are based on kinematic viscosity values = 1 mm²/s and density equal to 1000 kg/m³. Curve tolerance according to ISO 9906.

MODEL	ELECTRICAL DATA					
	POWER (kW)	MOTOR SIZE	POWER INPUT 50 Hz	In A		MOTOR TYPE
	4 POLES			IE2	IE3	
KDN 65-250	3	MEC 100L	3 x 400 V - Δ	6.25	-	IE2
	4	MEC 112M	3 x 400 V - Δ	7.95	-	IE2
	5.5	MEC 132S	3 x 400 V - Δ	10.6	-	IE2
	7.5	MEC 132M	3 x 400 V - Δ	14.2	14.6	IE2 / IE3
	11	MEC 160M	3 x 400 V - Δ	21.6	20.5	IE2 / IE3

MODEL	POWER (kW)	UNIT DIMENSIONS (mm)										FLANGE DIMENSIONS (mm)		STANDARD COUPLING				SPACER COUPLING				REF.
		A	A2	H2	H	H3	L1	L3	B2	B3	D	DNA	DNM	IE2		IE3		IE2		IE3		
		L	WEIGHT kg	L	WEIGHT kg	L	WEIGHT kg	L	WEIGHT kg	L	WEIGHT kg											
KDN 65-250	3	100	90	250	80	280	1120	740	490	440	24	80	65	960	178	-	-	1100	186	-	-	5
	4	100	90	250	80	280	1120	740	490	440	24	80	65	1045	185	-	-	1185	193	-	-	5
	5.5	100	90	250	80	280	1120	740	490	440	24	80	65	1045	201	-	-	1185	209	-	-	5
	7.5	100	90	250	80	280	1120	740	490	440	24	80	65	1085	257	1092	238	1225	265	1232	246	6
	11	100	90	250	80	280	1250	840	540	490	24	80	65	1190	257	1190	277	1330	265	1330	285	6

Dimension and electrical data based on sizing definition following the instructions on page 96.

KDN 65-315 - 4 POLES - STANDARDISED CENTRIFUGAL ELECTRIC PUMPS FOR AIR CONDITIONING, REFRIGERATION, IRRIGATION, DECANTING, PRESSURISATION SYSTEMS, AND INDUSTRIAL APPLICATIONS

Pumped liquid temperature range: from -10 °C to +140 °C - Maximum ambient temperature: +40°C

= 1450 1/min

CENTRIFUGAL PUMPS

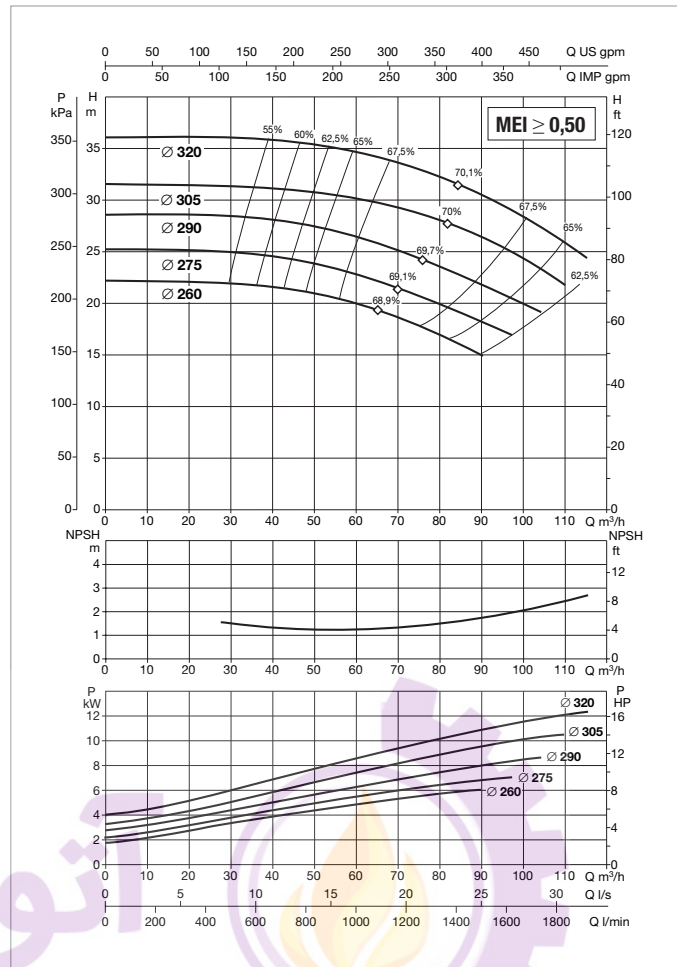
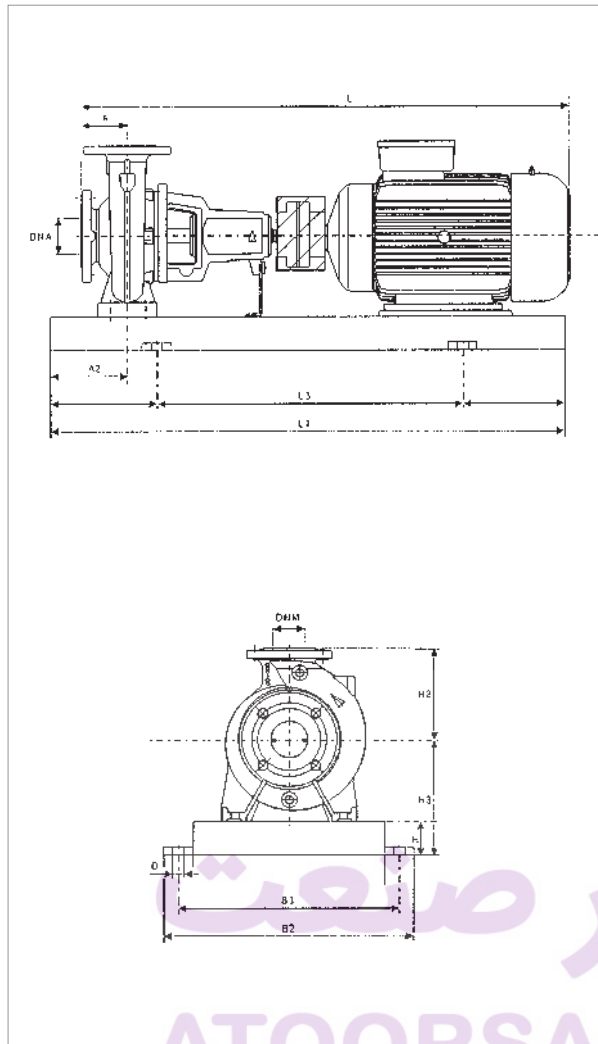

See hydraulic efficiency details on page 291.

The performance curves are based on kinematic viscosity values = 1 mm²/s and density equal to 1000 kg/m³. Curve tolerance according to ISO 9906.

MODEL	ELECTRICAL DATA					
	POWER (kW)	MOTOR SIZE	POWER INPUT 50 Hz	In A		MOTOR TYPE
	4 POLES			IE2	IE3	
KDN 65-315	5.5	MEC 132S	3 x 400 V - Δ	10.6	-	IE2
	7.5	MEC 132M	3 x 400 V - Δ	14.2	14.6	IE2 / IE3
	11	MEC 160M	3 x 400 V - Δ	21.6	20.5	IE2 / IE3
	15	MEC 160L	3 x 400 V - Δ	29	28	IE2 / IE3
	18.5	MEC 180M	3 x 400 V - Δ	33	34	IE2 / IE3

MODEL	POWER (kW)	UNIT DIMENSIONS (mm)										FLANGE DIMENSIONS (mm)		STANDARD COUPLING				SPACER COUPLING				REF.
		A	A2	H2	H	H3	L1	L3	B2	B3	D	DNA	DNM	IE2		IE3		IE2		IE3		
		L	WEIGHT kg	L	WEIGHT kg	L	WEIGHT kg	L	WEIGHT kg	L	WEIGHT kg	L	WEIGHT kg	L	WEIGHT kg	L	WEIGHT kg	L	WEIGHT kg			
KDN 65-315	5.5	125	90	280	80	305	1250	840	540	490	24	80	65	1070	259	-	-	1210	267	-	-	6
	7.5	125	90	280	80	305	1250	840	540	490	24	80	65	1110	292	1117	273	1250	300	1257	281	6
	11	125	90	280	80	305	1250	840	540	490	24	80	65	1215	297	1215	271	1355	305	1355	279	6
	15	125	90	280	100	325	1400	940	610	550	28	80	65	1220	297	1258	272	1360	305	1398	280	7
	18.5	125	90	280	100	325	1400	940	610	550	28	80	65	1290	322	1290	291	1430	330	1430	299	7

Dimension and electrical data based on sizing definition following the instructions on page 96.

KDN 80-160 - 4 POLES - STANDARDISED CENTRIFUGAL ELECTRIC PUMPS FOR AIR CONDITIONING, REFRIGERATION, IRRIGATION, DECANTING, PRESSURISATION SYSTEMS, AND INDUSTRIAL APPLICATIONS

Pumped liquid temperature range: from -10 °C to +140 °C - Maximum ambient temperature: +40°C

= 1450 1/min

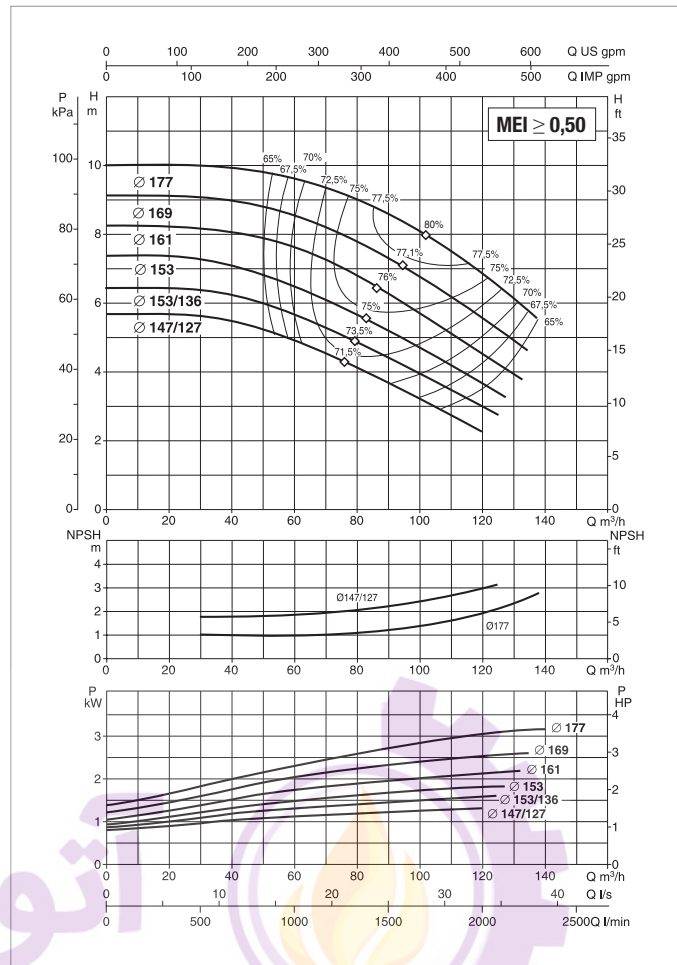
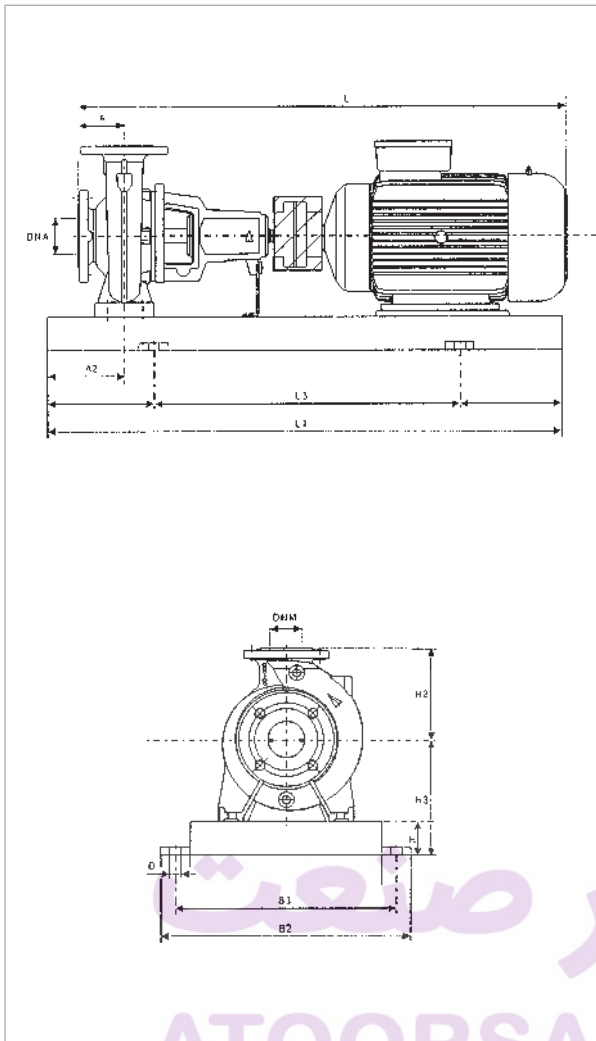

See hydraulic efficiency details on page 291.

The performance curves are based on kinematic viscosity values = 1 mm²/s and density equal to 1000 kg/m³. Curve tolerance according to ISO 9906.

MODEL	ELECTRICAL DATA					
	POWER (kW)	MOTOR SIZE	POWER INPUT 50 Hz	In A		MOTOR TYPE
	4 POLES			IE2	IE3	
KDN 80-160	1.1	MEC 90S	3 x 230 - 400 V ~	4.68/2.19	-	IE2
	1.5	MEC 90L	3 x 230 - 400 V ~	6.24/3.16	-	IE2
	2.2	MEC 100L	3 x 230 - 400 V ~	8.75/5.15	-	IE2
	3	MEC 100L	3 x 400 V - Δ	6.25	-	IE2
	4	MEC 112M	3 x 400 V - Δ	7.95	-	IE2
	5.5	MEC 132S	3 x 400 V - Δ	10.6	-	IE2

MODEL	POWER (kW)	UNIT DIMENSIONS (mm)										FLANGE DIMENSIONS (mm)		STANDARD COUPLING				SPACER COUPLING				REF.
		A	A2	H2	H	H3	L1	L3	B2	B3	D	DNA	DNM	IE2		IE3		IE2		IE3		
		L	WEIGHT kg	L	WEIGHT kg	L	WEIGHT kg	L	WEIGHT kg	L	WEIGHT kg	L	WEIGHT kg	L	WEIGHT kg	L	WEIGHT kg	L	WEIGHT kg			
KDN 80-160	1.1	125	75	225	80	260	1000	660	450	400	24	100	80	835	125	-	-	975	133	-	-	4
	1.5	125	75	225	80	260	1000	660	450	400	24	100	80	875	127	-	-	1015	135	-	-	4
	2.2	125	75	225	80	260	1000	660	450	400	24	100	80	875	139	-	-	1015	147	-	-	4
	3	125	75	225	80	260	1000	660	450	400	24	100	80	875	138	-	-	1015	146	-	-	4
	4	125	75	225	80	260	1000	660	450	400	24	100	80	960	138	-	-	1100	146	-	-	4
	5.5	125	75	225	80	260	1120	740	490	440	24	100	80	960	163	-	-	1100	171	-	-	5

Dimension and electrical data based on sizing definition following the instructions on page 96.

KDN 80-200 - 4 POLES - STANDARDISED CENTRIFUGAL ELECTRIC PUMPS FOR AIR CONDITIONING, REFRIGERATION, IRRIGATION, DECANTING, PRESSURISATION SYSTEMS, AND INDUSTRIAL APPLICATIONS

Pumped liquid temperature range: from -10 °C to +140 °C - Maximum ambient temperature: +40°C

= 1450 1/min

CENTRIFUGAL PUMPS

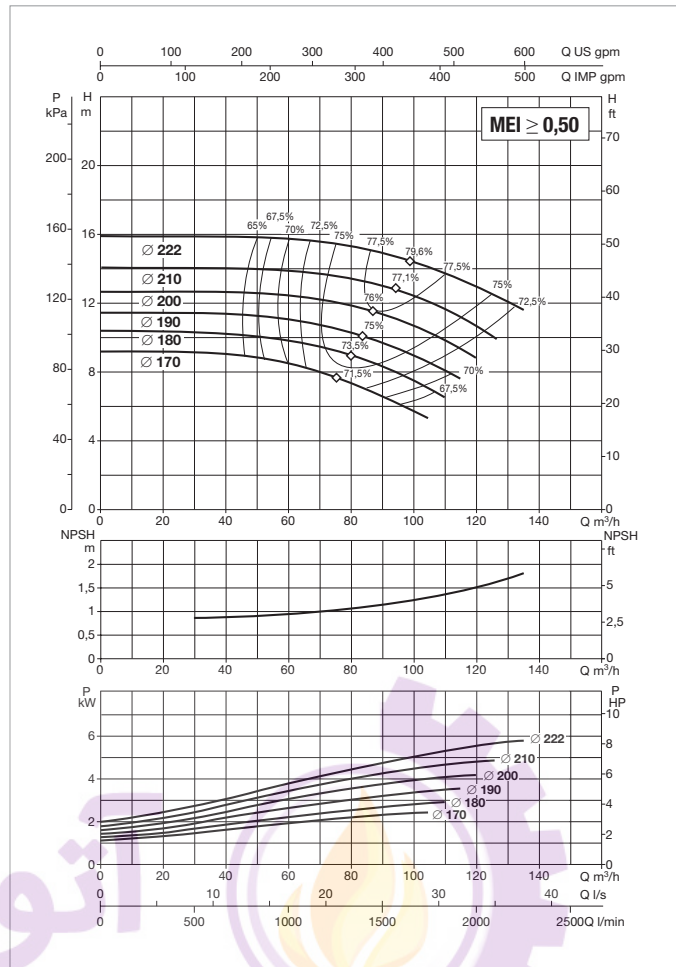
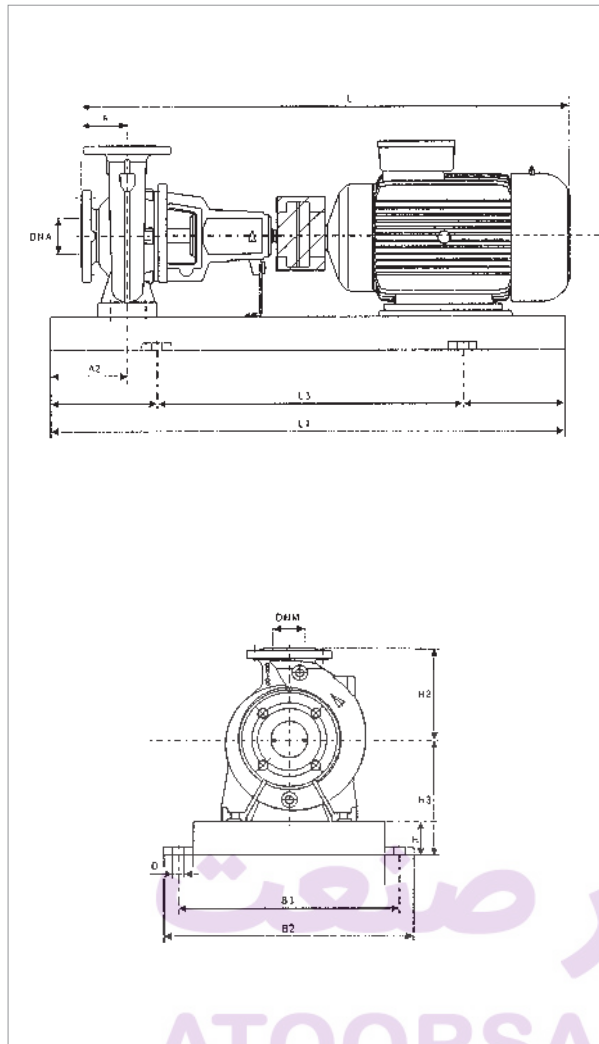

See hydraulic efficiency details on page 291.

The performance curves are based on kinematic viscosity values = 1 mm²/s and density equal to 1000 kg/m³. Curve tolerance according to ISO 9906.

MODEL	ELECTRICAL DATA					
	POWER (kW)	MOTOR SIZE	POWER INPUT 50 Hz	In A		MOTOR TYPE
	4 POLES			IE2	IE3	
KDN 80-200	1.5	MEC 90L	3 x 230 - 400 V ~	6.24/3.17	-	IE2
	2.2	MEC 100L	3 x 230 - 400 V ~	8.75/5.16	-	IE2
	3	MEC 100L	3 x 400 V - Δ	6.25	-	IE2
	4	MEC 112M	3 x 400 V - Δ	7.95	-	IE2
	5.5	MEC 132S	3 x 400 V - Δ	10.6	-	IE2
	7.5	MEC 132M	3 x 400 V - Δ	14.2	14.6	IE2 / IE3
	11	MEC 160M	3 x 400 V - Δ	21.6	20.5	IE2 / IE3

MODEL	POWER (kW)	UNIT DIMENSIONS (mm)										FLANGE DIMENSIONS (mm)		STANDARD COUPLING				SPACER COUPLING				REF.
		A	A2	H2	H	H3	L1	L3	B2	B3	D	DNA	DNM	IE2		IE3		IE2		IE3		
		L	WEIGHT kg	L	WEIGHT kg	L	WEIGHT kg	L	WEIGHT kg	L	WEIGHT kg											
KDN 80-200	1.5	125	75	250	80	260	1120	740	490	440	24	100	80	985	161	-	-	1125	169	-	-	5
	2.2	125	75	250	80	260	1120	740	490	440	24	100	80	985	166	-	-	1125	174	-	-	5
	3	125	75	250	80	260	1120	740	490	440	24	100	80	985	168	-	-	1125	176	-	-	5
	4	125	75	250	80	260	1120	740	490	440	24	100	80	1070	188	-	-	1210	196	-	-	5
	5.5	125	75	250	80	260	1120	740	490	440	24	100	80	1070	188	-	-	1210	196	-	-	5
	7.5	125	75	250	80	260	1120	740	490	440	24	100	80	1110	188	1117	169	1250	196	1257	177	5
	11	125	75	250	80	260	1250	840	540	490	24	100	80	1215	197	1215	171	1355	205	1355	179	6

Dimension and electrical data based on sizing definition following the instructions on page 96.

KDN 80-250 - 4 POLES - STANDARDISED CENTRIFUGAL ELECTRIC PUMPS FOR AIR CONDITIONING, REFRIGERATION, IRRIGATION, DECANTING, PRESSURISATION SYSTEMS, AND INDUSTRIAL APPLICATIONS

Pumped liquid temperature range: from -10 °C to +140 °C - Maximum ambient temperature: +40°C

= 1450 1/min

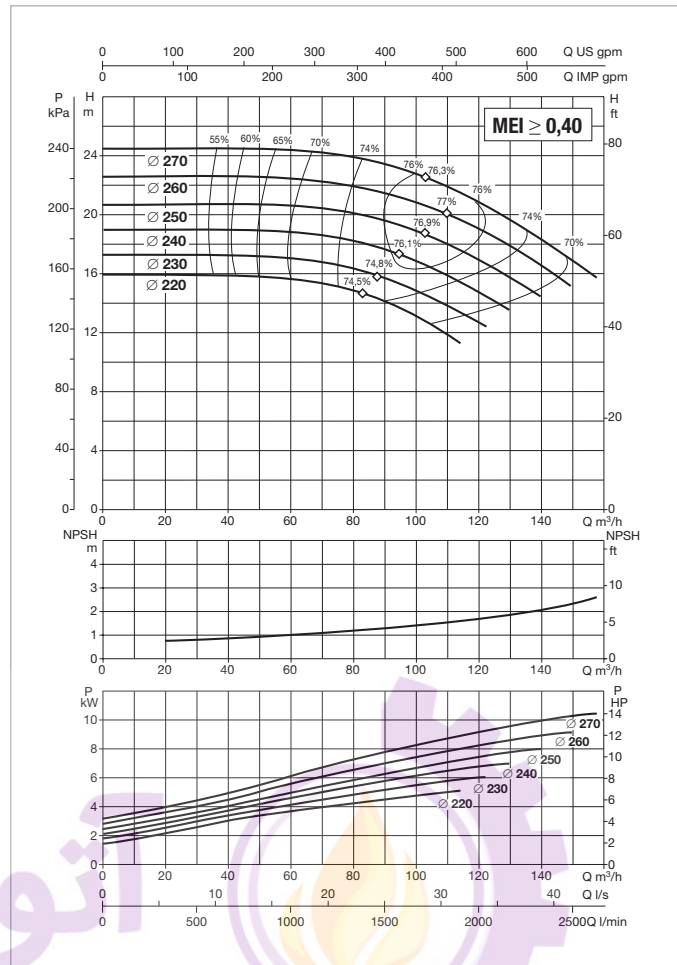
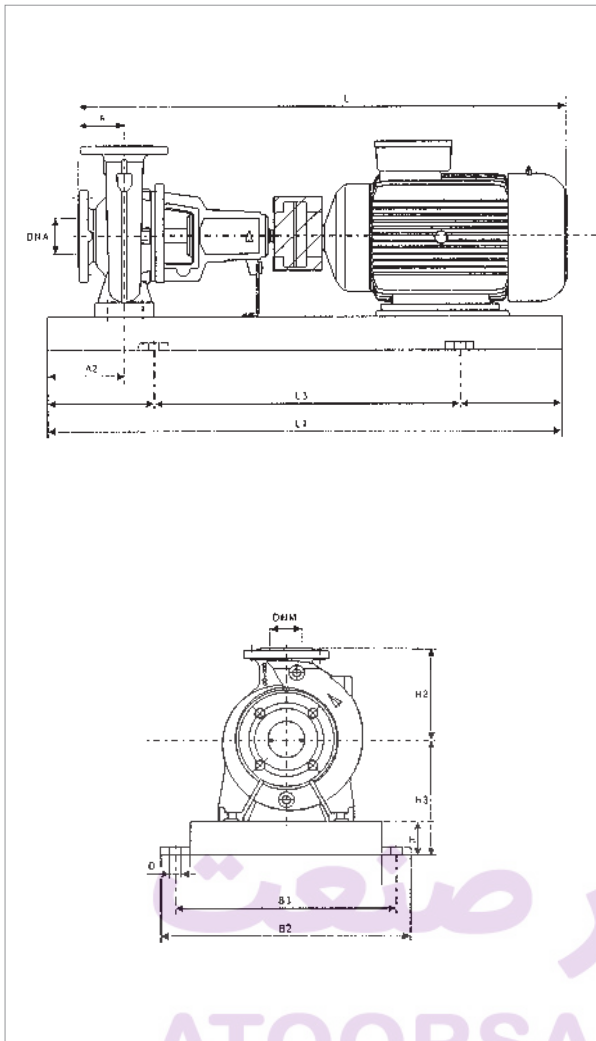

See hydraulic efficiency details on page 291.

The performance curves are based on kinematic viscosity values = 1 mm²/s and density equal to 1000 kg/m³. Curve tolerance according to ISO 9906.

MODEL	ELECTRICAL DATA					
	POWER (kW)	MOTOR SIZE	POWER INPUT 50 Hz	In A		MOTOR TYPE
	4 POLES			IE2	IE3	
KDN 80-250	4	MEC 112M	3 x 400 V - Δ	7.95	-	IE2
	5.5	MEC 132S	3 x 400 V - Δ	10.6	-	IE2
	7.5	MEC 132M	3 x 400 V - Δ	14.2	14.6	IE2 / IE3
	11	MEC 160M	3 x 400 V - Δ	21.6	20.5	IE2 / IE3
	15	MEC 160L	3 x 400 V - Δ	29	28	IE2 / IE3

MODEL	POWER (kW)	UNIT DIMENSIONS (mm)										FLANGE DIMENSIONS (mm)		STANDARD COUPLING				SPACER COUPLING				REF.
		A	A2	H2	H	H3	L1	L3	B2	B3	D	DNA	DNM	IE2		IE3		IE2		IE3		
		L	WEIGHT kg	L	WEIGHT kg	L	WEIGHT kg	L	WEIGHT kg	L	WEIGHT kg											
KDN 80-250	4	125	90	280	80	280	1250	840	540	490	24	100	80	1070	219	-	-	1210	227	-	-	6
	5.5	125	90	280	80	280	1250	840	540	490	24	100	80	1070	219	-	-	1210	227	-	-	6
	7.5	125	90	280	80	280	1250	840	540	490	24	100	80	1110	219	1117	200	1250	227	1257	208	6
	11	125	90	280	80	280	1250	840	540	490	24	100	80	1215	258	1215	232	1355	266	1355	240	6
	15	125	90	280	80	280	1250	840	540	490	24	100	80	1220	277	1258	252	1360	285	1398	260	6

Dimension and electrical data based on sizing definition following the instructions on page 96.

KDN 80-315 - 4 POLES - STANDARDISED CENTRIFUGAL ELECTRIC PUMPS FOR AIR CONDITIONING, REFRIGERATION, IRRIGATION, DECANTING, PRESSURISATION SYSTEMS, AND INDUSTRIAL APPLICATIONS

Pumped liquid temperature range: from -10 °C to +140 °C - Maximum ambient temperature: +40°C

= 1450 1/min

CENTRIFUGAL PUMPS

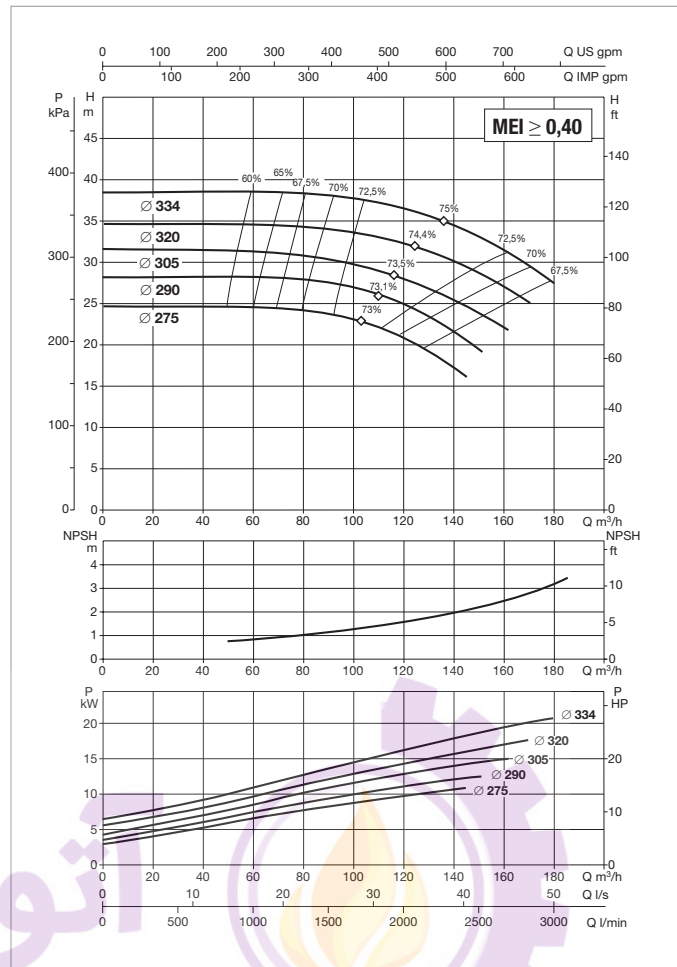
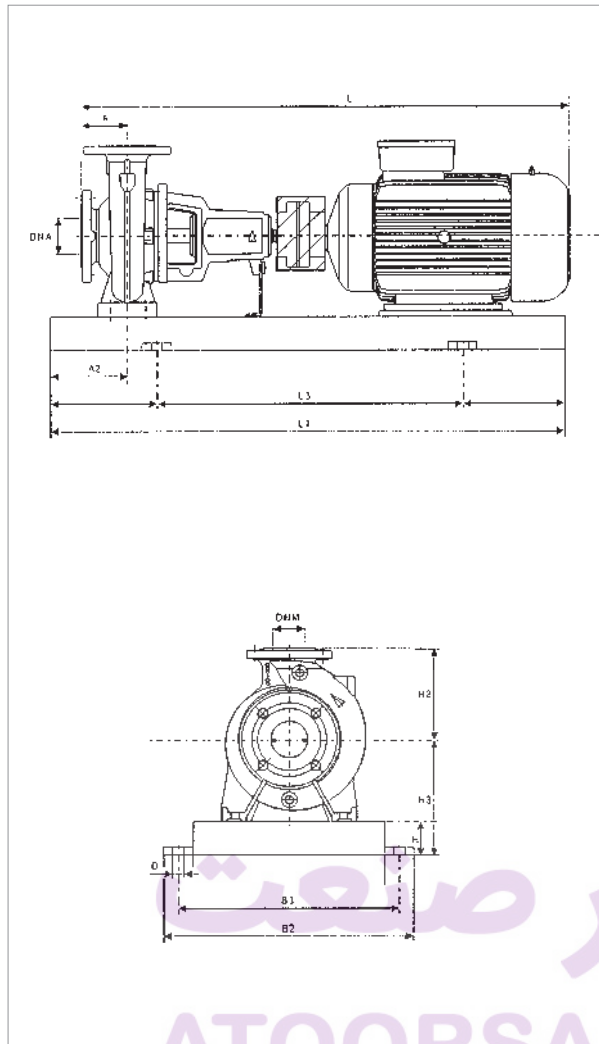

See hydraulic efficiency details on page 291.

The performance curves are based on kinematic viscosity values = 1 mm²/s and density equal to 1000 kg/m³. Curve tolerance according to ISO 9906.

MODEL	ELECTRICAL DATA					
	POWER (kW)	MOTOR SIZE	POWER INPUT 50 Hz	In A		MOTOR TYPE
	4 POLES			IE2	IE3	
KDN 80-315	7.5	MEC 132M	3 x 400 V - Δ	14.2	14.6	IE2 / IE3
	11	MEC 160M	3 x 400 V - Δ	21.6	20.5	IE2 / IE3
	15	MEC 160L	3 x 400 V - Δ	29	28	IE2 / IE3
	18.5	MEC 180M	3 x 400 V - Δ	33	34	IE2 / IE3
	22	MEC 180L	3 x 400 V - Δ	40	40.5	IE2 / IE3
	30	MEC 200L	3 x 400 V - Δ	53.5	53.5	IE2 / IE3

MODEL	POWER (kW)	UNIT DIMENSIONS (mm)									FLANGE DIMENSIONS (mm)		STANDARD COUPLING				SPACER COUPLING				REF.	
		A	A2	H2	H	H3	L1	L3	B2	B3	D	DNA	DNM	IE2		IE3		IE2		IE3		
		L	WEIGHT kg	L	WEIGHT kg	L	WEIGHT kg	L	WEIGHT kg	L	WEIGHT kg	L	WEIGHT kg	L	WEIGHT kg	L	WEIGHT kg	L	WEIGHT kg			
KDN 80-315	7.5	125	90	315	80	330	1250	840	540	490	24	100	80	1110	390	1117	371	1250	398	1257	379	6
	11	125	90	315	80	330	1250	840	540	490	24	100	80	1215	390	1215	364	1355	398	1355	372	6
	15	125	90	315	100	350	1400	940	610	550	28	100	80	1220	390	1258	365	1360	398	1398	373	7
	18.5	125	90	315	100	350	1400	940	610	550	28	100	80	1290	409	1290	378	1430	417	1430	386	7
	22	125	90	315	100	350	1400	940	610	550	28	100	80	1328	348	1328	318	1468	356	1468	326	7
	30	125	90	315	100	350	1400	940	610	550	28	100	80	1370	384	1380	384	1510	392	1520	392	7

Dimension and electrical data based on sizing definition following the instructions on page 96.

KDN 100-200 - 4 POLES - STANDARDISED CENTRIFUGAL ELECTRIC PUMPS FOR AIR CONDITIONING, REFRIGERATION, IRRIGATION, DECANTING, PRESSURISATION SYSTEMS, AND INDUSTRIAL APPLICATIONS

Pumped liquid temperature range: from -10 °C to +140 °C - Maximum ambient temperature: +40°C

= 1450 1/min

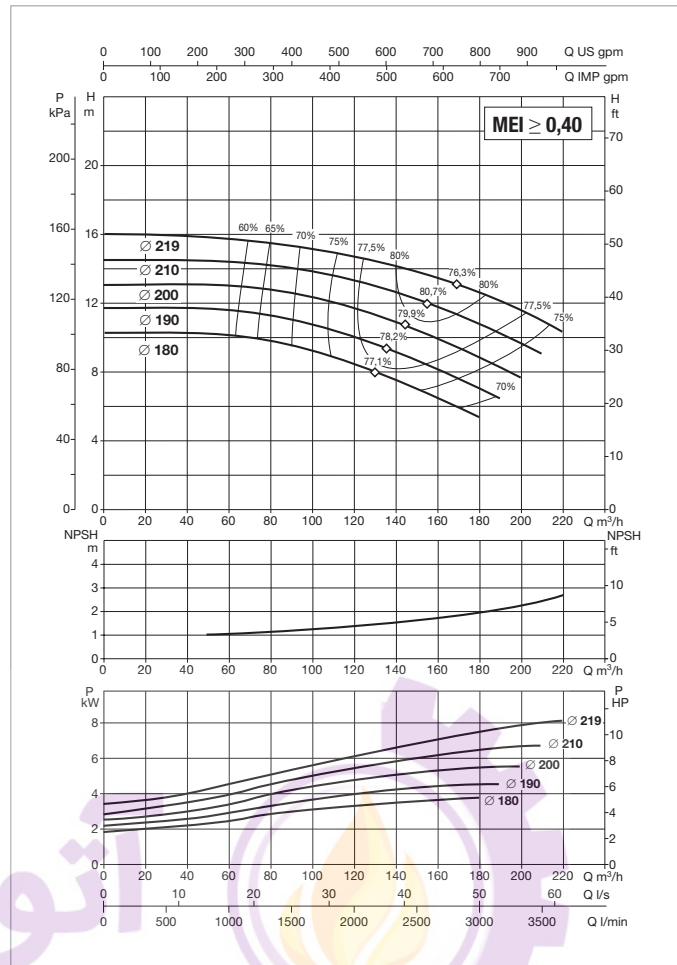
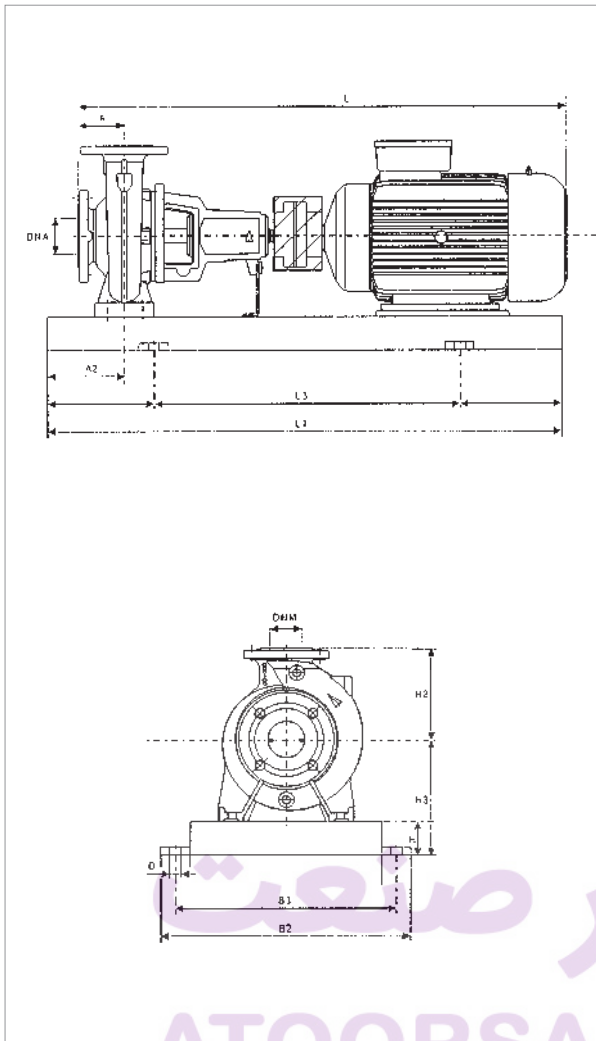

See hydraulic efficiency details on page 291.

The performance curves are based on kinematic viscosity values = 1 mm²/s and density equal to 1000 kg/m³. Curve tolerance according to ISO 9906.

MODEL	ELECTRICAL DATA					
	POWER (kW)	MOTOR SIZE	POWER INPUT 50 Hz	In A		MOTOR TYPE
	4 POLES			IE2	IE3	
KDN 100-200	3	MEC 100L	3 x 400 V - Δ	6.25	-	IE2
	4	MEC 112M	3 x 400 V - Δ	7.95	-	IE2
	5.5	MEC 132S	3 x 400 V - Δ	10.6	-	IE2
	7.5	MEC 132M	3 x 400 V - Δ	14.2	14.6	IE2 / IE3
	11	MEC 160M	3 x 400 V - Δ	21.6	20.5	IE2 / IE3
	15	MEC 160L	3 x 400 V - Δ	29	28	IE2 / IE3

MODEL	POWER (kW)	UNIT DIMENSIONS (mm)										FLANGE DIMENSIONS (mm)		STANDARD COUPLING				SPACER COUPLING				REF.
		A	A2	H2	H	H3	L1	L3	B2	B3	D	DNA	DNM	IE2		IE3		IE2		IE3		
		L	WEIGHT kg	L	WEIGHT kg	L	WEIGHT kg	L	WEIGHT kg	L	WEIGHT kg	L	WEIGHT kg	L	WEIGHT kg	L	WEIGHT kg	L	WEIGHT kg			
KDN 100-200	3	125	90	280	80	280	1120	740	490	440	24	125	100	985	181	-	-	1125	189	-	-	5
	4	100	90	280	80	280	1120	740	490	440	24	125	100	1070	188	-	-	1210	196	-	-	5
	5.5	100	90	280	80	280	1120	740	490	440	24	125	100	1070	214	-	-	1210	222	-	-	5
	7.5	100	90	280	80	280	1120	740	490	440	24	125	100	1110	209	1117	190	1250	217	1257	198	5
	11	100	90	280	80	280	1250	840	540	490	24	125	100	1215	307	1215	281	1355	315	1355	289	6
	15	100	90	280	80	280	1250	840	540	490	24	125	100	1220	380	1258	355	1360	388	1398	363	6

Dimension and electrical data based on sizing definition following the instructions on page 96.

KDN 100-250 - 4 POLES - STANDARDISED CENTRIFUGAL ELECTRIC PUMPS FOR AIR CONDITIONING, REFRIGERATION, IRRIGATION, DECANTING, PRESSURISATION SYSTEMS, AND INDUSTRIAL APPLICATIONS

Pumped liquid temperature range: from -10 °C to +140 °C - Maximum ambient temperature: +40°C

= 1450 1/min

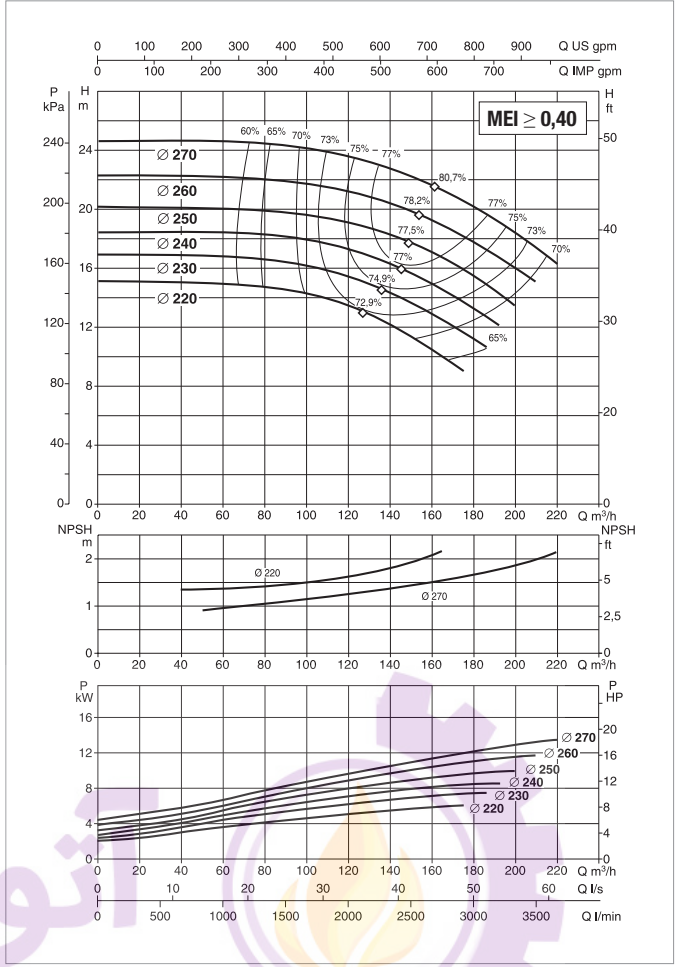
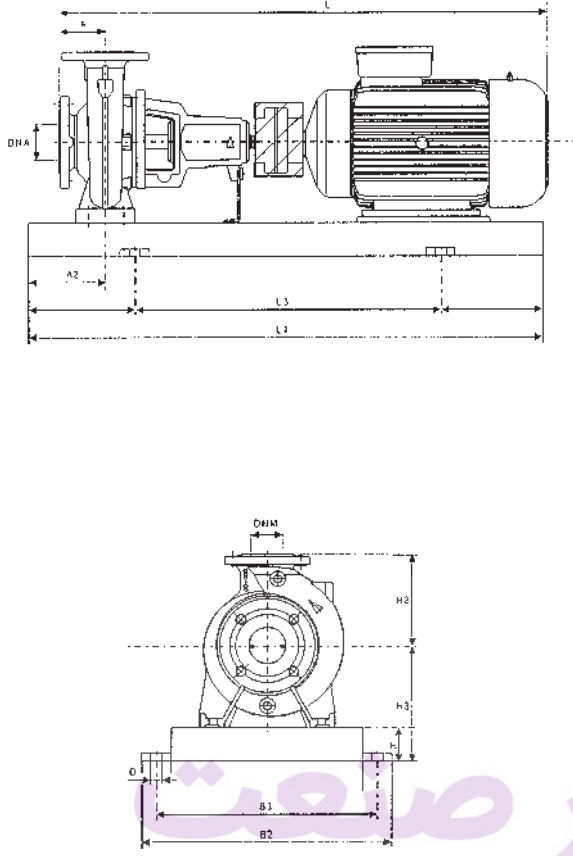

See hydraulic efficiency details on page 291.

The performance curves are based on kinematic viscosity values = 1 mm²/s and density equal to 1000 kg/m³. Curve tolerance according to ISO 9906.

MODEL	ELECTRICAL DATA					
	POWER (kW)	MOTOR SIZE	POWER INPUT 50 Hz	In A		MOTOR TYPE
	4 POLES			IE2	IE3	
KDN 100-250	5.5	MEC 132S	3 x 400 V - Δ	10.6	-	IE2
	7.5	MEC 132M	3 x 400 V - Δ	14.2	14.6	IE2 / IE3
	11	MEC 160M	3 x 400 V - Δ	21.6	20.5	IE2 / IE3
	15	MEC 160L	3 x 400 V - Δ	29	28	IE2 / IE3
	18.5	MEC 180M	3 x 400 V - Δ	33	34	IE2 / IE3

MODEL	POWER (kW)	UNIT DIMENSIONS (mm)											FLANGE DIMENSIONS (mm)		STANDARD COUPLING				SPACER COUPLING				REF.
		A	A2	H2	H	H3	L1	L3	B2	B3	D	DNA	DNM	IE2		IE3		IE2		IE3			
		L	WEIGHT kg	L	WEIGHT kg	L	WEIGHT kg	L	WEIGHT kg														
KDN 100-250	5.5	140	90	280	80	305	1250	840	540	490	24	125	100	1085	241	-	-	1225	249	-	-	6	
	7.5	140	90	280	80	305	1250	840	540	490	24	125	100	1125	250	1132	231	1265	258	1272	239	6	
	11	140	90	280	80	305	1250	840	540	490	24	125	100	1230	292	1230	266	1370	300	1370	274	6	
	15	140	90	280	100	325	1400	940	610	550	28	125	100	1235	300	1273	275	1375	308	1413	283	7	
	18.5	140	90	280	100	325	1400	940	610	550	28	125	100	1305	578	1305	547	1445	586	1445	555	7	

Dimension and electrical data based on sizing definition following the instructions on page 96.

KDN 100-315 - 4 POLES - STANDARDISED CENTRIFUGAL ELECTRIC PUMPS FOR AIR CONDITIONING, REFRIGERATION, IRRIGATION, DECANTING, PRESSURISATION SYSTEMS, AND INDUSTRIAL APPLICATIONS

Pumped liquid temperature range: from -10 °C to +140 °C - Maximum ambient temperature: +40°C

= 1450 1/min

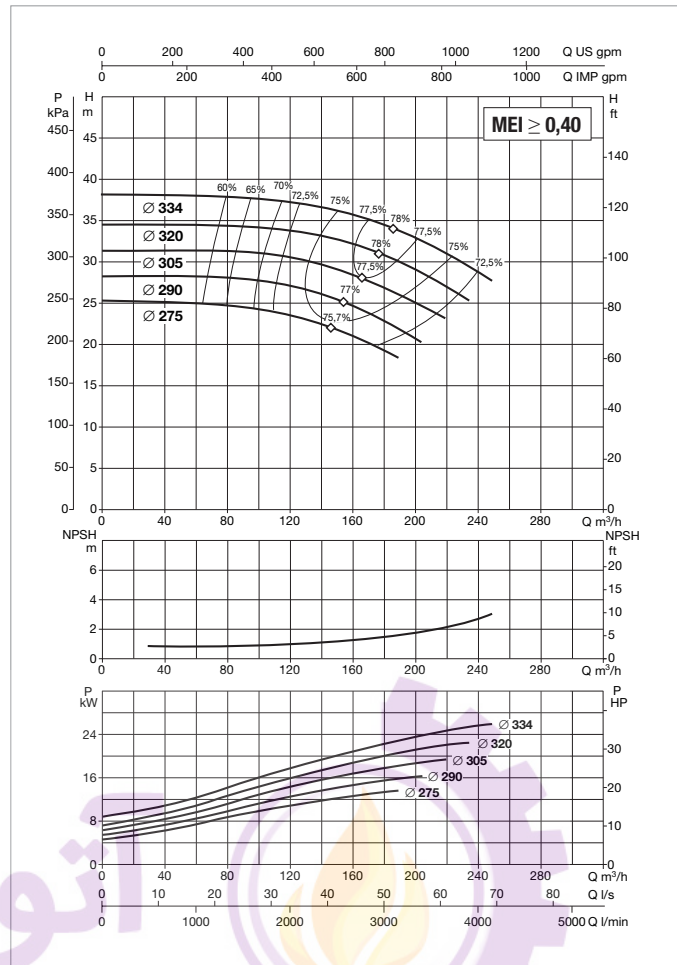
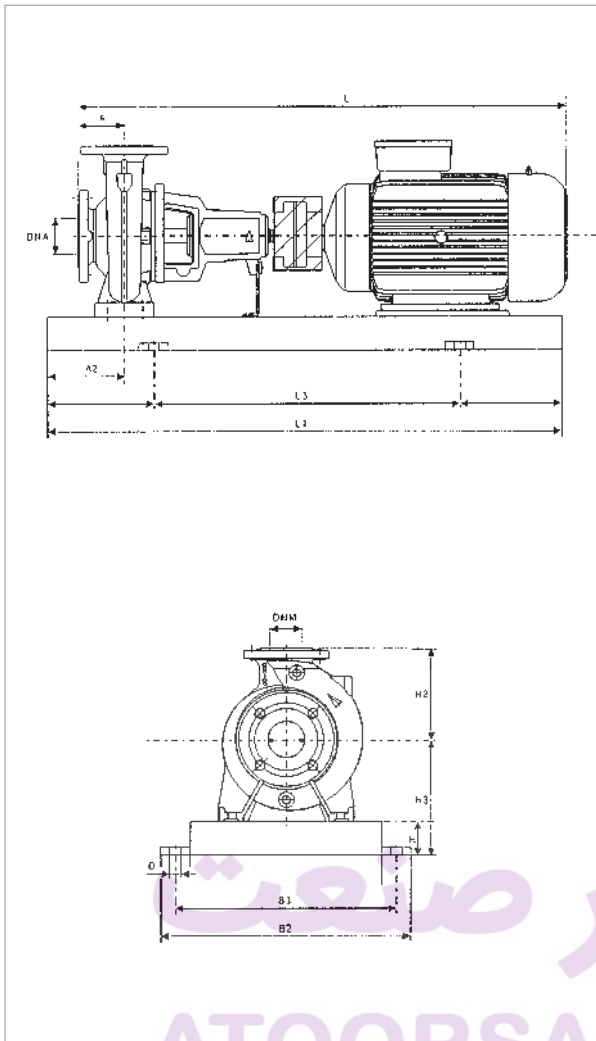

See hydraulic efficiency details on page 291.

The performance curves are based on kinematic viscosity values = 1 mm²/s and density equal to 1000 kg/m³. Curve tolerance according to ISO 9906.

MODEL	ELECTRICAL DATA					
	POWER (kW) 4 POLES	MOTOR SIZE	POWER INPUT 50 Hz	In A		MOTOR TYPE
				IE2	IE3	
KDN 100-315	11	MEC 160M	3 x 400 V - Δ	21.6	20.5	IE2 / IE3
	15	MEC 160L	3 x 400 V - Δ	29	28	IE2 / IE3
	18.5	MEC 180M	3 x 400 V - Δ	33	34	IE2 / IE3
	22	MEC 180L	3 x 400 V - Δ	40	40.5	IE2 / IE3
	30	MEC 200L	3 x 400 V - Δ	53.5	53.5	IE2 / IE3
	37	MEC 225S	3 x 400 V - Δ	66.5	65	IE2 / IE3

MODEL	POWER (kW)	UNIT DIMENSIONS (mm)										FLANGE DIMENSIONS (mm)		STANDARD COUPLING				SPACER COUPLING				REF.
		A	A2	H2	H	H3	L1	L3	B2	B3	D	DNA	DNM	IE2		IE3		IE2		IE3		
		L	WEIGHT kg	L	WEIGHT kg	L	WEIGHT kg	L	WEIGHT kg	L	WEIGHT kg	L	WEIGHT kg	L	WEIGHT kg	L	WEIGHT kg	L	WEIGHT kg			
KDN 100-315	11	140	90	315	80	330	1250	840	540	490	24	125	100	1230	313	1230	287	1370	321	1370	295	6
	15	140	90	315	100	350	1400	940	610	550	28	125	100	1325	300	1273	275	1375	308	1413	283	7
	18.5	140	90	315	100	350	1400	940	610	550	28	125	100	1305	346	1305	315	1445	354	1445	323	7
	22	140	90	315	100	350	1400	940	610	550	28	125	100	1343	372	1343	342	1483	380	1483	350	7
	30	140	90	315	100	350	1400	940	610	550	28	125	100	1385	458	1395	458	1525	466	1535	466	7
	37	140	90	315	100	350	1400	940	610	550	28	125	100	1430	518	1440	524	1570	526	1580	532	7

Dimension and electrical data based on sizing definition following the instructions on page 96.

KDN 125-250 - 4 POLES - STANDARDISED CENTRIFUGAL ELECTRIC PUMPS FOR AIR CONDITIONING, REFRIGERATION, IRRIGATION, DECANTING, PRESSURISATION SYSTEMS, AND INDUSTRIAL APPLICATIONS

Pumped liquid temperature range: from -10 °C to +140 °C - Maximum ambient temperature: +40°C

= 1450 1/min

CENTRIFUGAL PUMPS

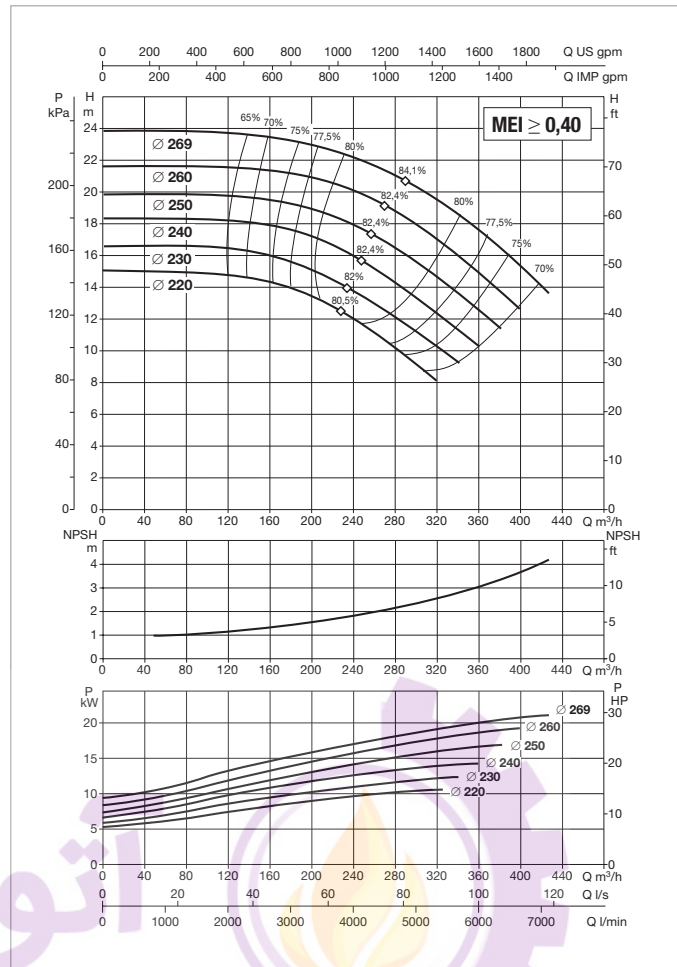
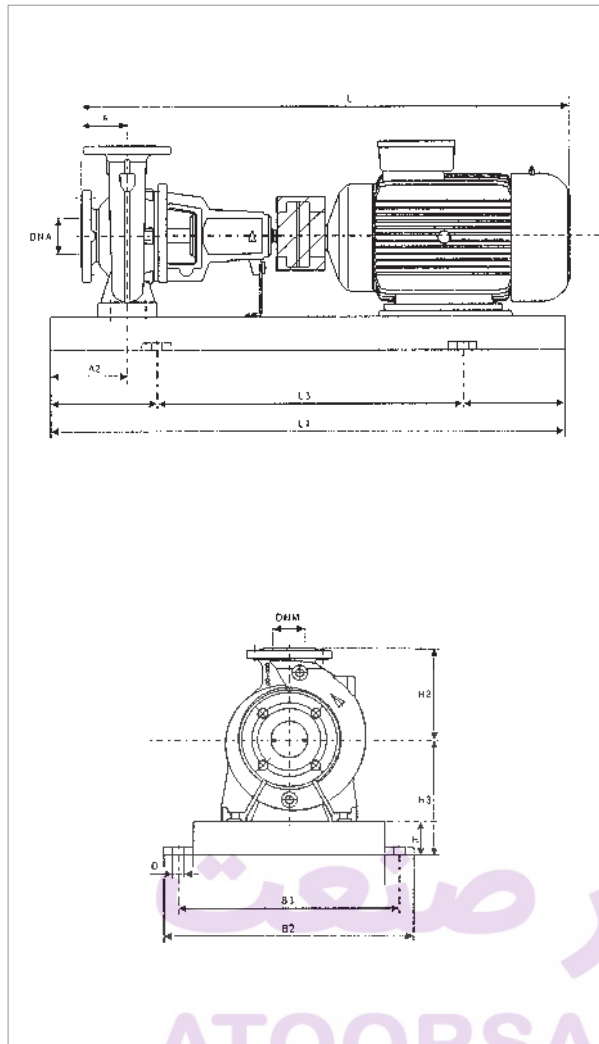

See hydraulic efficiency details on page 291.

The performance curves are based on kinematic viscosity values = 1 mm²/s and density equal to 1000 kg/m³. Curve tolerance according to ISO 9906.

MODEL	ELECTRICAL DATA					
	POWER (kW) 4 POLES	MOTOR SIZE	POWER INPUT 50 Hz	In A		MOTOR TYPE
				IE2	IE3	
KDN 125-250	7.5	MEC 132M	3 x 400 V - Δ	14.2	14.6	IE2 / IE3
	11	MEC 160M	3 x 400 V - Δ	21.6	20.5	IE2 / IE3
	15	MEC 160L	3 x 400 V - Δ	29	28	IE2 / IE3
	18.5	MEC 180M	3 x 400 V - Δ	33	34	IE2 / IE3
	22	MEC 180L	3 x 400 V - Δ	40	40.5	IE2 / IE3
	30	MEC 200L	3 x 400 V - Δ	53.5	53.5	IE2 / IE3

MODEL	POWER (kW)	UNIT DIMENSIONS (mm)									FLANGE DIMENSIONS (mm)		STANDARD COUPLING				SPACER COUPLING				REF.	
		A	A2	H2	H	H3	L1	L3	B2	B3	D	DNA	DNM	IE2		IE3		IE2		IE3		
		L	WEIGHT kg	L	WEIGHT kg	L	WEIGHT kg	L	WEIGHT kg	L	WEIGHT kg	L	WEIGHT kg	L	WEIGHT kg	L	WEIGHT kg	L	WEIGHT kg			
KDN 125-250	7.5	140	90	355	80	330	1250	840	540	490	24	150	125	1125	310	1132	291	1265	318	1272	299	6
	11	140	90	355	80	330	1250	840	540	490	24	150	125	1230	328	1230	302	1370	336	1370	310	6
	15	140	90	355	100	350	1400	940	610	550	28	150	125	1235	416	1273	391	1375	424	1413	399	7
	18.5	140	90	355	100	350	1400	940	610	550	28	150	125	1305	422	1305	391	1445	430	1445	399	7
	22	140	90	355	100	350	1400	940	610	550	28	150	125	1343	463	1343	433	1483	471	1483	441	7
	30	140	90	355	100	350	1400	940	610	550	28	150	125	1385	511	1395	511	1525	519	1535	519	7

Dimension and electrical data based on sizing definition following the instructions on page 96.

KDN 150-200 - 4 POLES - STANDARDISED CENTRIFUGAL ELECTRIC PUMPS FOR AIR CONDITIONING, REFRIGERATION, IRRIGATION, DECANTING, PRESSURISATION SYSTEMS, AND INDUSTRIAL APPLICATIONS

Pumped liquid temperature range: from -10 °C to +140 °C - Maximum ambient temperature: +40°C

= 1450 1/min

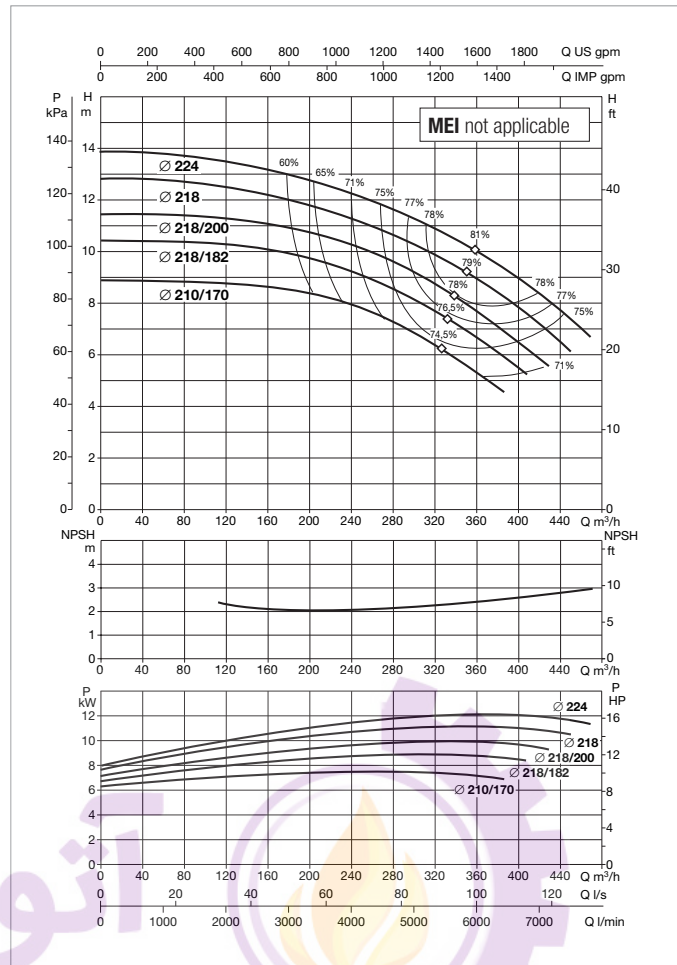
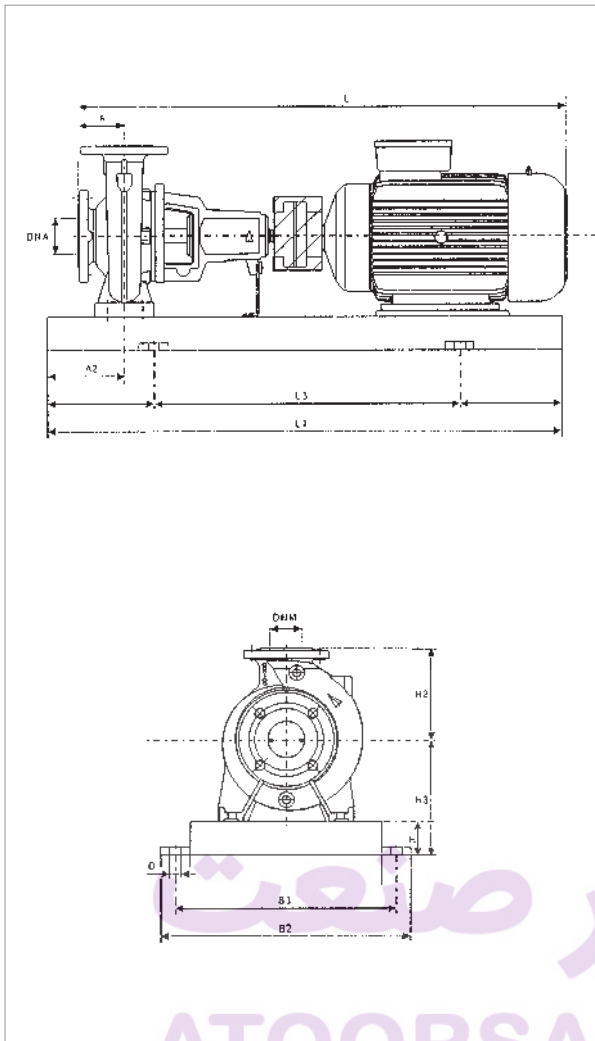

See hydraulic efficiency details on page 291.

The performance curves are based on kinematic viscosity values = 1 mm²/s and density equal to 1000 kg/m³. Curve tolerance according to ISO 9906.

MODEL	ELECTRICAL DATA					
	POWER (kW)	MOTOR SIZE	POWER INPUT 50 Hz	In A		MOTOR TYPE
	4 POLES			IE2	IE3	
KDN 150-200	5.5	MEC 132S	3 x 400 V - Δ	10.6	-	IE2
	7.5	MEC 132M	3 x 400 V - Δ	14.2	14.6	IE2 / IE3
	11	MEC 160M	3 x 400 V - Δ	21.6	20.5	IE2 / IE3
	15	MEC 160L	3 x 400 V - Δ	29	28	IE2 / IE3
	18.5	MEC 180M	3 x 400 V - Δ	33	34	IE2 / IE3

MODEL	POWER (kW)	UNIT DIMENSIONS (mm)									FLANGE DIMENSIONS (mm)		STANDARD COUPLING				SPACER COUPLING				REF.	
		A	A2	H2	H	H3	L1	L3	B2	B3	D	DNA	DNM	IE2		IE3		IE2		IE3		
		L	WEIGHT kg	L	WEIGHT kg	L	WEIGHT kg	L	WEIGHT kg	L	WEIGHT kg	L	WEIGHT kg	L	WEIGHT kg	L	WEIGHT kg	L	WEIGHT kg			
KDN 150-200	5.5	160	110	400	100	380	1800	1200	730	670	28	200	150	1105	454	-	-	1245	462	-	-	9
	7.5	160	110	400	100	380	1800	1200	730	670	28	200	150	1145	470	1152	451	1285	478	1292	459	9
	11	160	110	400	100	380	1800	1200	730	670	28	200	150	1250	481	1250	455	1390	489	1390	463	9
	15	160	110	400	100	380	1800	1200	730	670	28	200	150	1255	501	1293	476	1395	509	1433	484	9
	18.5	160	110	400	100	380	1800	1200	730	670	28	200	150	1325	535	1325	504	1465	543	1465	512	9

Dimension and electrical data based on sizing definition following the instructions on page 96.

KDN - 4 POLES

STANDARDISED CENTRIFUGAL ELECTRIC PUMPS

IE2 STANDARD MOTOR ELECTRIC DATA

=1450 1/min

MOTOR TYPE	P2 NOMINAL kW	SPEED rpm	YIELD %	POWER FACTOR COS φ	POWER INPUT 50 Hz	In A		Start-up current Ia/In	Start-up torque Ma/Mn	Maximum torque M/k/Mn	POLES
						230	400				
MEC 71	0.25	1400	60.00	0.710	3 x 230/400	1.60	0.90	2.88	2.15	2.26	4
MEC 71	0.37	1340	67.00	0.780	3 x 230/400	1.70	0.98	4.75	2.84	2.64	4
MEC 80	0.55	1410	71.00	0.720	3 x 230/400	2.60	1.50	5.33	2.78	2.89	4
MEC 80	0.75	1430	79.80	0.795	3 x 230/400	3.57	2.06	6.65	3.58	3.54	4
MEC 90S	1.10	1440	82.20	0.723	3 x 230/400	4.68	2.70	7.27	3.43	3.47	4
MEC 90L	1.50	1430	82.56	0.732	3 x 230/400	6.24	3.60	6.67	3.39	3.30	4
MEC 100L	2.20	1450	83.38	0.756	3 x 230/400	8.75	5.05	8.40	3.45	3.75	4

MOTOR TYPE	P2 NOMINAL kW	SPEED rpm	YIELD %	POWER FACTOR COS φ	POWER INPUT 50 Hz	In A		Start-up current Ia/In	Start-up torque Ma/Mn	Maximum torque M/k/Mn	POLES
						400	690				
MEC 100L	3.00	1440	86.72	0.800	3 x 400 Δ	6.25	3.61	6.91	2.70	3.11	4
MEC 112M	4.00	1450	87.19	0.832	3 x 400 Δ	7.95	4.59	8.72	3.17	3.53	4
MEC 132S	5.50	1460	88.78	0.851	3 x 400 Δ	10.60	6.15	7.97	2.37	3.13	4
MEC 132M	7.50	1460	89.81	0.849	3 x 400 Δ	14.20	8.20	8.70	2.62	3.07	4
MEC 160M	11.00	1470	90.44	0.818	3 x 400 Δ	21.60	12.47	8.32	2.70	2.95	4
MEC 160L	15.00	1470	90.48	0.834	3 x 400 Δ	29.00	16.74	8.16	2.58	2.96	4
MEC 180M	18.50	1470	92.00	0.873	3 x 400 Δ	33.00	19.05	7.66	2.93	3.23	4
MEC 180L	22.00	1470	92.31	0.862	3 x 400 Δ	40.00	23.09	7.86	2.63	3.19	4
MEC 200L	30.00	1480	92.80	0.874	3 x 400 Δ	53.31	30.78	8.72	3.17	3.53	4
MEC 225S	37.00	1480	93.22	0.865	3 x 400 Δ	66.50	38.39	6.74	2.13	2.86	4
MEC 225M	45.00	1480	93.09	0.881	3 x 400 Δ	79.50	45.90	7.53	2.34	2.92	4
MEC 250M	55.00	1490	94.22	0.843	3 x 400 Δ	98.00	56.58	8.47	2.82	3.36	4
MEC 280S	75.00	1480	94.48	0.876	3 x 400 Δ	132.00	76.50	8.69	2.96	3.56	4
MEC 280M	90.00	1480	94.78	0.895	3 x 400 Δ	154.00	89.00	9.49	3.42	3.80	4
MEC 315S	110.00	1490	94.70	0.877	3 x 400 Δ	195.00	112.59	7.14	2.51	3.44	4
MEC 315M	132.00	1490	94.80	0.879	3 x 400 Δ	235.00	135.68	7.08	2.55	3.39	4
MEC 315L	160.00	1490	95.00	0.877	3 x 400 Δ	285.00	164.55	7.18	2.67	3.40	4
MEC 315L	200.00	1490	95.10	0.874	3 x 400 Δ	350.00	202.08	7.25	2.77	3.41	4
MEC355M	250.00	1490	96.01	0.88	3 x 400 Δ	425.00	246.40	7.27	2.42	3.50	4
MEC355L	315.00	1490	95.98	0.88	3 x 400 Δ	538.00	311.88	8.08	2.46	3.83	4

KDN - 4 POLES

STANDARDISED CENTRIFUGAL ELECTRIC PUMPS

IE3 STANDARD MOTOR ELECTRIC DATA

=1450 1/min

MOTOR TYPE	P2 NOMINAL kW	SPEED rpm	YIELD %	POWER FACTOR COS φ	POWER INPUT 50 Hz	In A		Start-up current Ia/In	Start-up torque Ma/Mn	Maximum torque M/k/Mn	POLES
						400	690				
MEC 132M	7.50	1460	90.40	0.820	3 x 400 Δ	14.60	8.44	8.50	2.70	3.20	4
MEC 160M	11.00	1470	91.40	0.850	3 x 400 Δ	20.50	11.85	8.40	2.90	3.10	4
MEC 160L	15.00	1470	92.10	0.850	3 x 400 Δ	28.00	16.18	8.30	2.90	3.00	4
MEC 180M	18.50	1470	92.60	0.850	3 x 400 Δ	34.00	19.65	7.90	2.40	3.00	4
MEC 180L	22.00	1470	92.90	0.850	3 x 400 Δ	40.50	23.41	8.30	2.60	3.10	4
MEC 200L	30.00	1470	93.60	0.870	3 x 400 Δ	53.50	30.92	8.60	2.80	3.40	4
MEC 225S	37.00	1480	93.90	0.880	3 x 400 Δ	65.00	37.57	7.50	2.20	2.60	4
MEC 225M	45.00	1480	94.20	0.880	3 x 400 Δ	78.50	45.38	8.00	2.50	2.80	4
MEC 250M	55.00	1480	94.60	0.870	3 x 400 Δ	96.00	55.49	8.10	2.40	2.80	4
MEC 280S	75.00	1490	95.00	0.880	3 x 400 Δ	130.00	75.14	7.40	2.20	2.90	4
MEC 280M	90.00	1490	95.20	0.880	3 x 400 Δ	156.00	90.17	6.80	2.10	2.60	4
MEC 315S	110.00	1490	95.40	0.860	3 x 400 Δ	190.00	109.83	6.90	2.20	3.00	4
MEC 315M	132.00	1490	95.60	0.860	3 x 400 Δ	230.00	132.95	6.90	2.30	3.00	4
MEC 315L	160.00	1490	95.80	0.870	3 x 400 Δ	275.00	158.96	6.90	2.30	2.90	4
MEC 315L	200.00	1490	96.00	0.880	3 x 400 Δ	340.00	196.53	6.70	2.30	2.80	4
MEC 355M	250.00	1490	96.00	0.890	3 x 400 Δ	420.00	242.77	7.70	2.60	2.70	4
MEC 355L	315.00	1490	96.00	0.890	3 x 400 Δ	530.00	306.36	7.80	2.80	2.70	4

KDN - 2 POLE RANGE

STANDARDISED CENTRIFUGAL ELECTRIC PUMPS

PERFORMANCE RANGE

The performance curves are based on kinematic viscosity values = 1 mm²/s and density equal to 1000 kg/m³. Curve tolerance according to ISO 9906.

GRAPHIC SELECTION TABLE

= 2900 1/min

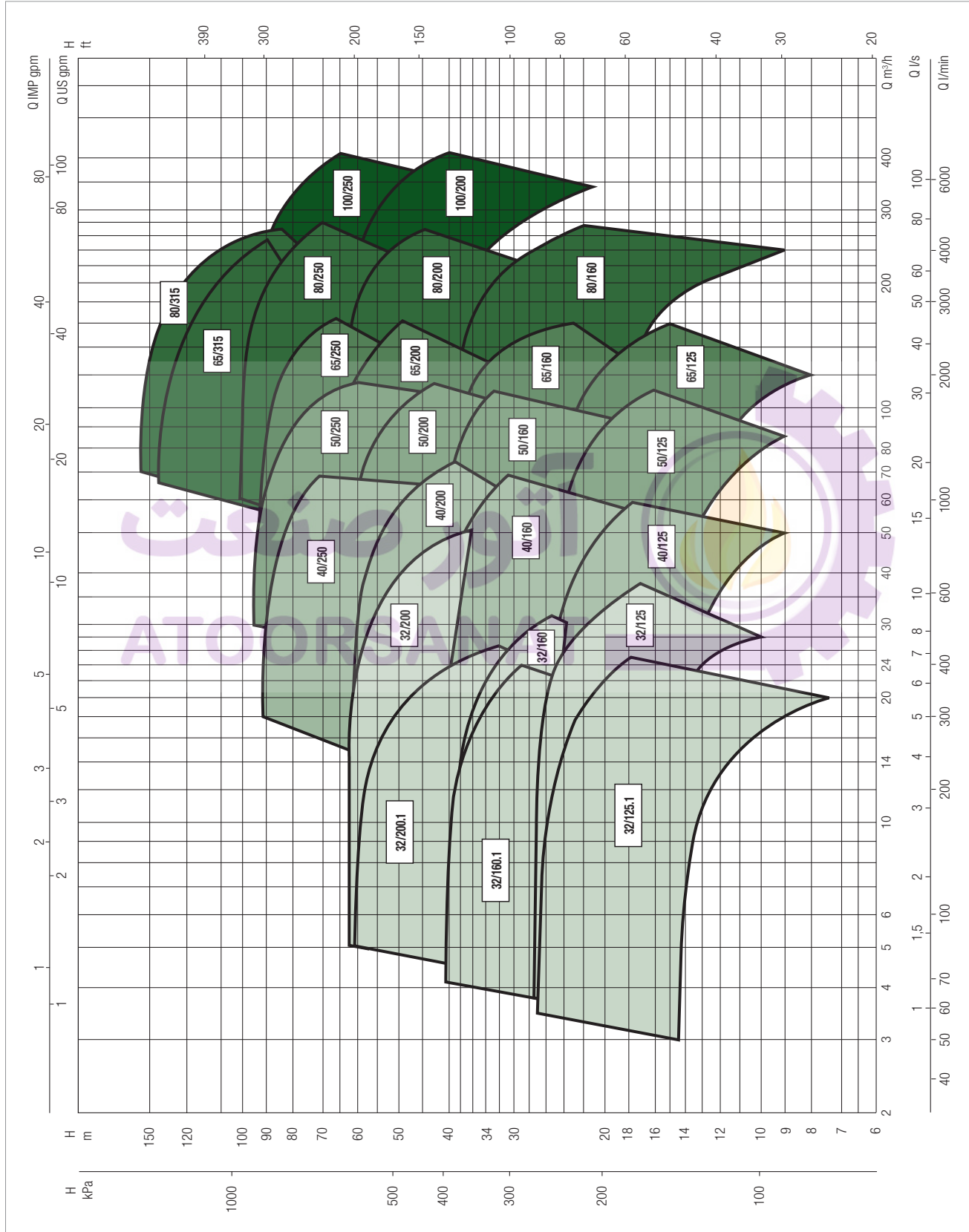

SELECTION TABLE - KDN 32

MODEL	Q=m ³ /h	0	6	12	18	24	30	36	42	48
	Q=l/min	0	100	200	300	400	500	600	700	800
KDN 32-125.1/105		13.8	13.6	12.3	9.7					
KDN 32-125.1/110		15.5	15.2	13.9	11.5					
KDN 32-125.1/115		17.1	16.8	15.5	13.2					
KDN 32-125.1/120		18.8	18.5	17.3	15.1					
KDN 32-125.1/125		20.5	20.3	19.1	17					
KDN 32-125.1/130		22.3	22.2	21.3	19					
KDN 32-125.1/135		24.4	24.1	23.3	21.1	17.8				
KDN 32-125.1/140		26.5	26.4	25.6	23.4	20.1				
KDN 32-125/115		17.3		16.5	15.1	12.9				
KDN 32-125/120		19		18.2	17	14.9	11.1			
KDN 32-125/125		20.9		20.1	18.9	16.9	13.5			
KDN 32-125/130		22.9		22	21	19.1	16.2			
KDN 32-125/135		24.9		24	22.1	21.5	18.5	14.7		
KDN 32-125/142		27.8		27	26.1	24.5	21.7	18		
KDN 32-160.1/137		21.5	21.2	19.3						
KDN 32-160.1/145		24.7	24.5	22.3	16.5					
KDN 32-160.1/153		28.3	28	26	20.5					
KDN 32-160.1/161		32	31.8	30	25					
KDN 32-160.1/169		36	35.7	34.4	29.5					
KDN 32-160.1/177		39.5	39.3	38.2	34.5	26				
KDN 32-160/137		23.7		22.6	20.7	17.6				
KDN 32-160/145		27		25.8	23.9	21.2	16.9			
KDN 32-160/153		30.4		29.5	27.7	25.8	21.2			
KDN 32-160/161		34		33	31.7	29.1	25.5			
KDN 32-160/169		38		37.3	36	33.6	35.7	26.5		
KDN 32-160/177		41.8		41.5	40.5	38.4	35.3	31.4		
KDN 32-200.1/170		34.3	34.2	31.9	23.5					
KDN 32-200.1/180		39.4	39.2	36.7	30					
KDN 32-200.1/190		45.3	44.7	41.5	35.5					
KDN 32-200.1/200		51.5	51	47.3	41	35				
KDN 32-200.1/207		55.3	55	51.8	46.4	37				
KDN 32-200/170		34		33	31	27	21			
KDN 32-200/180		39		38.5	36.5	32.5	28			
KDN 32-200/190		45		43.5	42	39	34	28.5		
KDN 32-200/200		51		49	48	45	40.5	35		
KDN 32-200/210		57		56	55	52.5	48.5	43	36	
KDN 32-200/219		63		62	61	59	56.5	52.5	46.5	39.5

H
(m)

KDN - 2 POLES

STANDARDISED CENTRIFUGAL ELECTRIC PUMPS

SELECTION TABLE - KDN 40

MODEL	Q=m ³ /h	0	6	12	18	24	30	36	42	48	54	60	66	72
	Q=l/min	0	100	200	300	400	500	600	700	800	900	1000	1100	1200
KDN 40-125/115	H (m)	16.8		13.3	15.6	15	14.3	13.2	12.6	9.8				
KDN 40-125/120		18.5		18	17.5	17	16	15	13.5	11.8				
KDN 40-125/125		20.4		20	19.5	19	18	16.7	15.3	13.5				
KDN 40-125/130		22		21.8	21.5	21	20	19	17.5	15.7	14			
KDN 40-125/135		24.1		24	23.9	23.4	22.5	21.5	20	18.3	16.4			
KDN 40-125/142		26.8		26.6	26.4	26	25.3	24.4	23	21.4	19.4	17		
KDN 40-160/137		23.9			23.8	23	22	20.5	18	15				
KDN 40-160/145		27.5			27.4	27	25.7	24.2	22.1	19.5				
KDN 40-160/153		31.1			31	30.5	29.5	28	26.5	24	21			
KDN 40-160/161		34.5			34.5	34.4	33.7	32.3	30.5	28.5	25.8	22.5		
KDN 40-160/169		38.4			38.4	38.2	38	37	35	33.5	31	28		
KDN 40-160/177		42.6			42.5	42.4	42	41.5	40	38.5	35	33	30	
KDN 40-200/170		33.6			33	32.6	32	30	26.5	22.5				
KDN 40-200/180		38.8			38.5	38	37	35	32.5	29	25			
KDN 40-200/190		43.4			43.1	43	42.7	41	38	35	31.5	27		
KDN 40-200/200		48.7			48.4	48.2	47.5	46.5	44	41.5	38.5	34.5		
KDN 40-200/210		54.3			54.1	54	53.6	53	51	48.5	46	42.5	38	
KDN 40-200/219		60			59.8	59.7	59.4	59	57	55	52.5	49.5	46	40
KDN 40-250/220		63.1			62.8	62.5	61	59	57	55	52	48		
KDN 40-250/230		69.5			69.3	68.5	67.8	66	63.5	61	58	55	51	
KDN 40-250/240		76.3			76	75.8	75	73	70.5	68	65	62	58.5	
KDN 40-250/250		82.8			82.5	82	81.8	80	78	75.5	72.5	69	66	
KDN 40-250/260		91			90.5	90	89.5	88.5	86.5	84	81	78	74	

SELECTION TABLE - KDN 50

MODEL	Q=m ³ /h	0	6	12	18	24	30	36	42	48	54	60	66	72	78	84	90	102	114		
	Q=l/min	0	100	200	300	400	500	600	700	800	900	1000	1100	1200	1300	1400	1500	1700	1900		
KDN 50-125/115	H (m)	17.1					15.9	15.5	15	14.3	13.6	13	12.2	11.5	10.4	9					
KDN 50-125/120		18.2					17.5	17	16.5	16	15.3	14.7	14	13.2	12	11.2	10				
KDN 50-125/125		19.8					19.4	19	18.5	17.9	17.4	16.6	16	15.1	14	13	11.8				
KDN 50-125/130		21.5					21.1	20.8	20.5	19.8	19.2	18.5	17.8	17	16.5	15.2	14				
KDN 50-125/135		23.2					23	22.6	22.3	21.8	21.2	20.6	19.9	19.3	18.4	17.5	16.3	13.7			
KDN 50-125/139		24.7					24.5	24.3	24	23.5	23	22.4	21.6	20.8	20	19.2	18	15.5			
KDN 50-125/144		25.9					26.5	26.4	26.1	25.6	25.1	24.5	24	23.2	22.3	21.5	20.5	17.8	15		
KDN 50-160/137		24.2					23.8	23.7	23.5	22.5	22	21	20.3	19	18	16.8	15				
KDN 50-160/145		27.2					27	26.9	26.6	26.4	25.5	25	23.8	23	21.5	20.5	19				
KDN 50-160/153		30.3					30.3	30.2	30	29.9	29.5	28.5	27.7	26.5	25.5	24.5	23				
KDN 50-160/161		33.8					33.7	33.7	33.6	33.6	33.3	32.5	31.8	31	29.8	28.5	27.5				
KDN 50-160/169		37.7					37.7	37.5	37.5	37.4	37	36.2	35.7	35.5	34.2	33	31.5	29			
KDN 50-160/177		41.6					41.5	41.5	41.3	41.2	41	40.6	40.5	39.5	38.8	38	36.7	33.5			
KDN 50-200/170		37.9					37	36.8	36.4	35	34	32	30	27	25						
KDN 50-200/180		42.5					42	41.7	41.4	40.5	39.5	38	36	34	32	29					
KDN 50-200/190		47.2					46.8	46.6	46	45.7	44.5	43.5	42	40	38	35.5	33				
KDN 50-200/200		52.4					52.2	52	18	51.5	50.5	49	47.5	46	44.5	42	40				
KDN 50-200/210		58.4					58.4	58.2	58	57.5	56.5	55.5	54	52.5	51	49	46.5	41.5			
KDN 50-200/219		64					64	64	64	63.5	62.5	61.5	60	58.5	57	55	53	48.5			
KDN 50-250/220		63.7					63.3	63.1	63	62	61	59	57.5	55	53	50	46.5	36			
KDN 50-250/230		69.6					69.3	69	68.8	68.5	68	66	64	62	60	57	54	45			
KDN 50-250/240		76					75.8	75.5	75.3	75	74.5	73	71.5	69	67	65	62	55			
KDN 50-250/250		83.2					83	82.9	82.8	83.5	82	80.5	78.5	77	75	72.5	70	64			
KDN 50-250/263		92.1					92	91.8	91.6	91.5	91.3	89.9	88.5	86.5	84.5	82.5	80	75	61		

KDN - 2 POLES

STANDARDISED CENTRIFUGAL ELECTRIC PUMPS

SELECTION TABLE - KDN 65

MODEL	Q=m ³ /h	0	48	54	60	66	72	78	84	90	102	114	120	150	180	210	240
	Q=l/min	0	800	900	1000	1100	1200	1300	1400	1500	1700	1900	2000	2500	3000	3500	4000
KDN 65-125/120/110	H (m)	16	14.4	14	13.6	13.1	12.8	12.2	11.9	11.4	10.2	8.7	8				
KDN 65-125/120		17.8	16	15.6	15.3	14.9	14.4	13.9	13.4	13	11.5	10.3	9.4				
KDN 65-125/125		19.4	17.8	17.5	17.1	16.8	16.4	16	15.4	15	13.5	12.2	11.4				
KDN 65-125/130		21	19.6	19.5	19.1	18.9	18.5	18	17.5	17	15.7	14.2	13.2				
KDN 65-125/135		22.6	21.8	21.5	21.3	21	20.5	20.1	19.6	19.2	18	16.5	15.6				
KDN 65-125/140		24	23.6	23.5	23.4	23	22.8	22.3	22	21.4	20.3	18.9	18	13.8			
KDN 65-125/144		25.6	25.5	25.4	25.2	25	24.6	24.3	24	23.4	22.5	21.1	20.2	16			
KDN 65-160/137		23.1	22.4	22	21.7	21.3	20.5	19.7	19	18	16						
KDN 65-160/145		26.2	25.7	25.5	25	24.6	24	23.5	22.7	22	20	17.8	16.5				
KDN 65-160/153		29.1	28.8	28.5	28.6	28.5	28	27.5	26.6	26	24	22	21				
KDN 65-160/161		32.6	32.5	32.4	32.3	32	31.7	31.3	30.5	30	28.5	26.5	25.5				
KDN 65-160/169		36.4	36.3	36.2	36.1	36	35.7	35.3	34.7	34	32.7	31	30				
KDN 65-160/177		40.1	39.9	39.8	39.7	40	39.8	39.5	39	38.5	37.2	35.5	34.7	28.5			
KDN 65-200/170		37.2	36.8	36.7	36.6	36.5	36	35	34	32.5	30	27	25				
KDN 65-200/180		41.7	41.4	41.3	41.2	41.1	41	40.5	40	39	36.5	34	32				
KDN 65-200/190		48.3	48.2	48.1	48	47.9	47.5	47	41	45	43	40.5	39				
KDN 65-200/200		53.2	53.1	52.9	52.8	52.7	52.5	52.3	52	51.8	50	48	46.5				
KDN 65-200/210		59.2	59.1	59	58.9	58.8	58.7	58.5	58.2	58	56.5	54.5	53.5				
KDN 65-200/219		64.9	64.9	64.8	64.5	64.3	64.1	64	63.8	62.5	62.4	61	60	52.5			
KDN 65-250/220		63.2	62.8	62.5	62	61	60	59.5	58	57	54	50.5	48				
KDN 65-250/230		69.5	69.5	69	68.5	68	67	66	65	64	63	58.5	56.5				
KDN 65-250/240		76	75.7	75.5	75	75	74	73	72	71	69	66	64				
KDN 65-250/250		83	82.3	82.3	82.2	82	81.5	81	80	79	76.5	73.5	72	60			
KDN 65-250/263		92.6	91.8	91.8	91.7	91.5	91.5	91	90	89.5	87.5	85	83	72.5			
KDN 65-315/260		92.8				92.7	91.9	90.9	89.7	88.5	85.5	81.9	79.9	67.8			
KDN 65-315/275		105				104.5	103.9	103.1	102.1	101.1	98.5	95.5	93.8	83.3	69.5		
KDN 65-315/290		117.1				117.0	116.5	115.9	115.1	114.3	112.2	109.7	108.3	99.4	87.6		
KDN 65-315/305		130				129.6	129.2	128.7	128.0	127.3	125.5	123.2	121.9	113.8	103.0	89.6	
KDN 65-315/320		143				142.9	142.6	142.1	141.6	140.9	139.3	137.3	136.2	128.9	119.1	106.8	92.0

SELECTION TABLE - KDN 80

MODEL	Q=m ³ /h	0	90	102	114	120	150	180	210	240	270	300
	Q=l/min	0	1500	1700	1900	2000	2500	3000	3500	4000	4500	5000
KDN 80-160/147/127	H (m)	23	21.5	207	20	19.5	17	14.5	11.8	8.8		
KDN 80-160/153/136		25.6	24.5	23.8	23	22.5	20.2	17.5	15	11.8		
KDN 80-160/153		29.3	28	27.3	26.5	26	23.5	20.7	16.5	14.5		
KDN 80-160/161		32.8	32	31.5	30.5	30	27.8	25	21.5	18.5		
KDN 80-160/169		36.5	35.7	35.2	34.5	34.2	32	29.5	26.5	22.6	18.5	
KDN 80-160/177		40	39.5	39.2	38.7	38.5	37	34.8	31.8	27.8	23	
KDN 80-200/170		36.6	35.7	35.5	34.5	34	31	27	21.5			
KDN 80-200/180		41	40.6	40.5	40	39.5	37	33	27.5			
KDN 80-200/190		45.7	45.4	45	44.5	44	42	29	34			
KDN 80-200/200		50.8	50.4	50.2	50	49.6	49	46.5	41	35		
KDN 80-200/210		56.3	55.9	55.8	55.7	55.6	54.8	52	48	43		
KDN 80-200/222		63.6	63.4	63.3	63.2	63.1	63	60	56.5	51.5	45	
KDN 80-250/220		62.6	62.5	62.4	62	61.8	60	55.5	49			
KDN 80-250/230		68.3	68.2	68.1	68	67.9	67	63	57	50		
KDN 80-250/240		75.5	75.4	75.3	75.2	75	74.5	71	65.5	58.5		
KDN 80-250/250		82.5	82.3	82	81.9	81.7	82	78.5	74	67.5	60.5	
KDN 80-250/260		90	89.7	89.6	86.5	89.3	89	86.5	82	77	70	61.5
KDN 80-250/270		97.9	97.8	97.5	91.3	97	96.5	94	89	84	77	69
KDN 80-315/275		101	101	100.8	100.8	100.7	100.1	97.6	92	82.7	73.5	
KDN 80-315/290		114	113.9	113.8	113.8	113.7	112	109.8	106.6	99.3	92.5	80.1

SELECTION TABLE - KDN 100

MODEL	Q=m ³ /h	0	150	180	210	240	270	300	330	360	390	420
	Q=l/min	0	2500	3000	3500	4000	4500	4500	5500	6000	6500	7000
KDN 100-200/180	H (m)	40.4	40	38	36	33	30.5	28	25			
KDN 100-200/190		46.5	45	44	42	39	37	34.5	31	28		
KDN 100-200/200		51.5	51	50	48.5	46	44	42	39	35	31.5	
KDN 100-200/210		57.5	57	56	55	53	51	49	46	43	39	36
KDN 100-200/219		64	62.5	62	61	60	58	56	53	50	47	43
KDN 100-250/220		61.1	60	59.5	57	54	50.5	46.5	42			
KDN 100-250/230		67.4	66.9	66.5	64	61	58	54	49	44		
KDN 100-250/240		73.5	72.9	71	70.5	69	66	63	58.5	53		
KDN 100-250/250		79.7	79.5	79	78.8	77	74	71	67	62.5		
KDN 100-250/260		88.6	88.2	88.1	88	86	83	79.5	76	71.5	66	

KDN 32-125.1 - 2 POLES - STANDARDISED CENTRIFUGAL ELECTRIC PUMPS FOR AIR CONDITIONING, REFRIGERATION, IRRIGATION, DECANTING, PRESSURISATION SYSTEMS, AND INDUSTRIAL APPLICATIONS

Pumped liquid temperature range: from -10 °C to +140 °C - Maximum ambient temperature: +40°C

= 2900 1/min

CENTRIFUGAL PUMPS

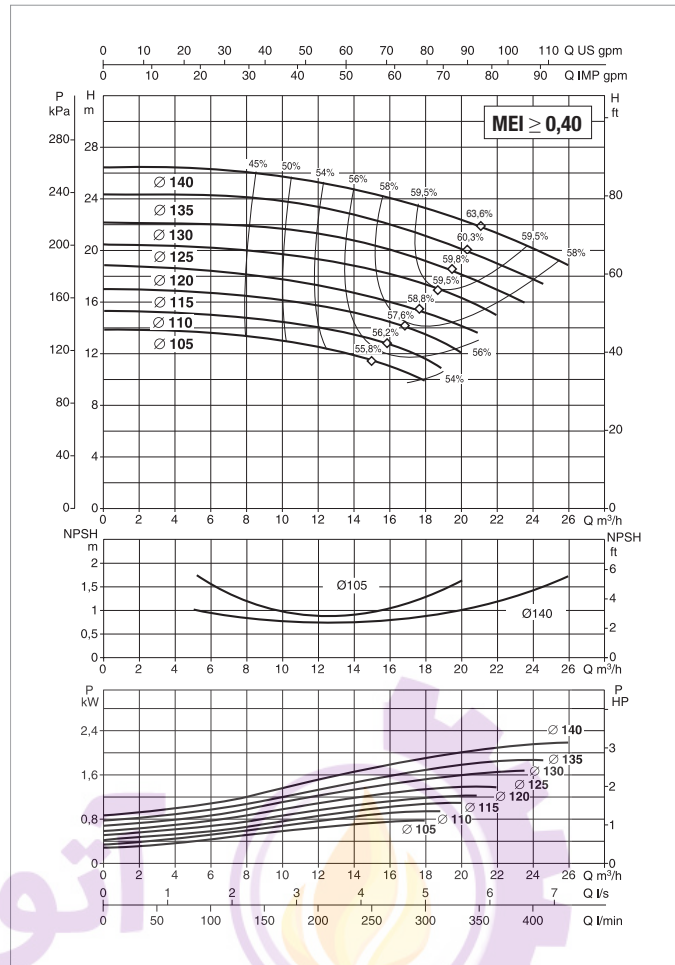
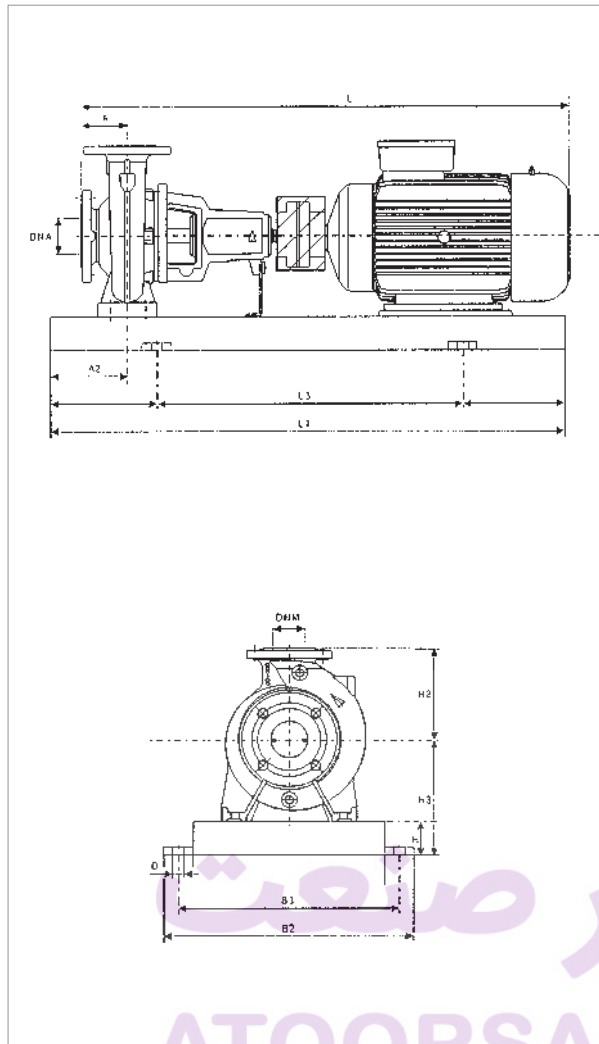

See hydraulic efficiency details on page 291.

The performance curves are based on kinematic viscosity values = 1 mm²/s and density equal to 1000 kg/m³. Curve tolerance according to ISO 9906.

MODEL	ELECTRICAL DATA					
	POWER (kW) 2 POLES	MOTOR SIZE	POWER INPUT 50 Hz	In A		MOTOR TYPE
				IE2	IE3	
KDN 32-125.1	0.75	MEC 80	3 x 230 - 400 V ~	2.81/1.62	-	IE2
	1.1	MEC 80	3 x 230 - 400 V ~	4.07/2.36	-	IE2
	1.5	MEC 90S	3 x 230 - 400 V ~	5.80/3.35	-	IE2
	2.2	MEC 90L	3 x 230 - 400 V ~	8.23/4.75	-	IE2
	3	MEC 100L	3 - 400 V - Δ	5.85	-	IE2
	4	MEC 112M	3 - 400 V - Δ	8.05	-	IE2

MODEL	POWER (kW)	UNIT DIMENSIONS (mm)										FLANGE DIMENSIONS (mm)		STANDARD COUPLING				SPACER COUPLING				REF.
		A	A2	H2	H	H3	L1	L3	B2	B3	D	DNA	DNM	IE2		IE3		IE2		IE3		
		L	WEIGHT kg	L	WEIGHT kg	L	WEIGHT kg	L	WEIGHT kg	L	WEIGHT kg	L	WEIGHT kg	L	WEIGHT kg	L	WEIGHT kg	L	WEIGHT kg			
KDN 32-125.1	0.75	80	60	140	65	177	800	540	360	320	19	50	32	740	85	-	-	840	90	-	-	2
	1.1	80	60	140	65	177	800	540	360	320	19	50	32	740	86	-	-	840	91	-	-	2
	1.5	80	60	140	65	177	800	540	360	320	19	50	32	765	93	-	-	865	98	-	-	3
	2.2	80	60	140	65	177	900	600	390	350	19	50	32	790	100	-	-	890	105	-	-	3
	3	80	60	140	65	177	900	600	390	350	19	50	32	830	102	-	-	930	107	-	-	3
	4	80	60	140	65	177	900	600	390	350	19	50	32	845	102	-	-	945	107	-	-	3

Dimension and electrical data based on sizing definition following the instructions on page 96.

KDN 32-125 - 2 POLES - STANDARDISED CENTRIFUGAL ELECTRIC PUMPS FOR AIR CONDITIONING, REFRIGERATION, IRRIGATION, DECANTING, PRESSURISATION SYSTEMS, AND INDUSTRIAL APPLICATIONS

Pumped liquid temperature range: from -10 °C to +140 °C - Maximum ambient temperature: +40°C

= 2900 1/min

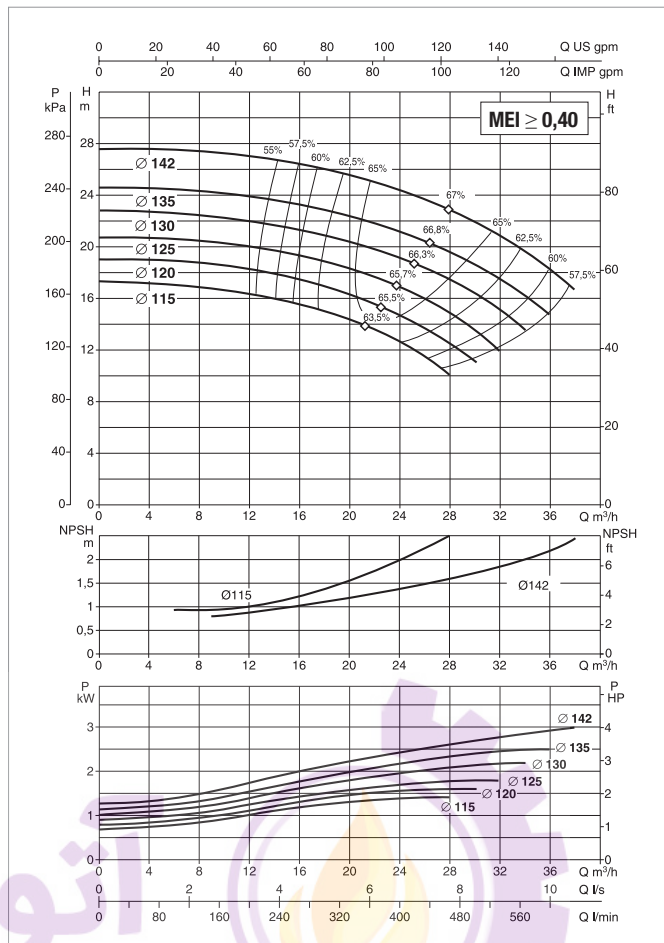
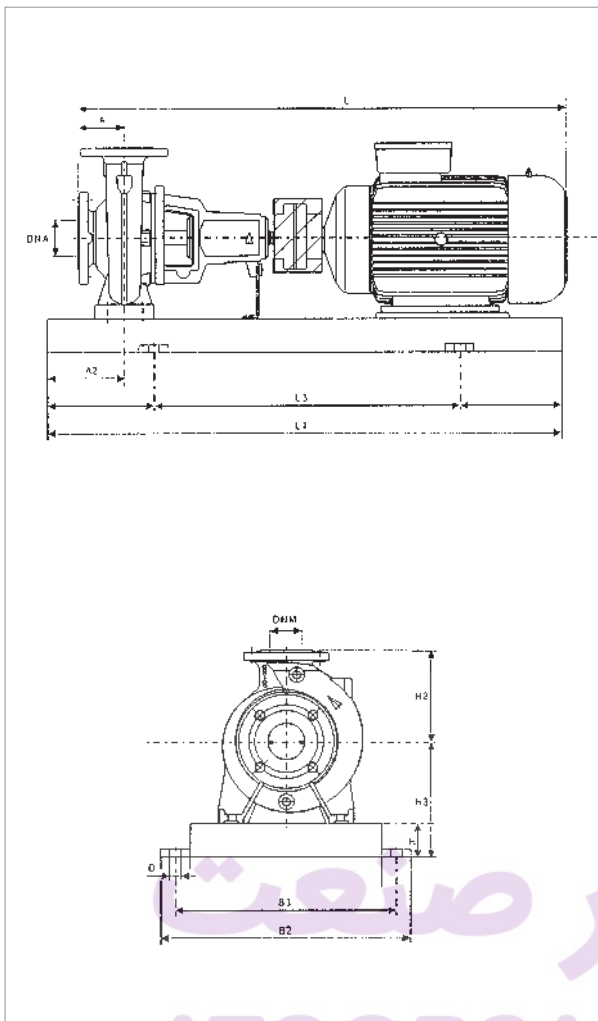

See hydraulic efficiency details on page 291.

The performance curves are based on kinematic viscosity values = 1 mm²/s and density equal to 1000 kg/m³. Curve tolerance according to ISO 9906.

آتور صنعت
ATOORSANAT

MODEL	ELECTRICAL DATA					
	POWER (kW)	MOTOR SIZE	POWER INPUT 50 Hz	In A		MOTOR TYPE
	2 POLES			IE2	IE3	
KDN 32-125	1.1	MEC 80	3 x 230 - 400 V ~	4.07/2.36	-	IE2
	1.5	MEC 90S	3 x 230 - 400 V ~	5.80/3.35	-	IE2
	2.2	MEC 90L	3 x 230 - 400 V ~	8.23/4.75	-	IE2
	3	MEC 100L	3 - 400 V - Δ	5.85	-	IE2
	4	MEC 112M	3 - 400 V - Δ	8.05	-	IE2

MODEL	POWER (kW)	UNIT DIMENSIONS (mm)										FLANGE DIMENSIONS (mm)		STANDARD COUPLING				SPACER COUPLING				REF.
		A	A2	H2	H	H3	L1	L3	B2	B3	D	DNA	DNM	IE2		IE3		IE2		IE3		
		L	WEIGHT kg	L	WEIGHT kg	L	WEIGHT kg	L	WEIGHT kg	L	WEIGHT kg	L	WEIGHT kg	L	WEIGHT kg	L	WEIGHT kg	L	WEIGHT kg			
KDN 32-125	1.1	80	60	140	65	177	800	540	360	320	19	50	32	740	85	-	-	840	90	-	-	2
	1.5	80	60	140	65	177	800	540	360	320	19	50	32	765	86	-	-	865	91	-	-	2
	2.2	80	60	140	65	177	900	600	390	350	19	50	32	790	93	-	-	890	98	-	-	3
	3	80	60	140	65	177	900	600	390	350	19	50	32	830	96.3	-	-	930	101.3	-	-	3
	4	80	60	140	65	177	900	600	390	350	19	50	32	845	117	-	-	945	122	-	-	3

Dimension and electrical data based on sizing definition following the instructions on page 96.

KDN 32-160.1 - 2 POLES - STANDARDISED CENTRIFUGAL ELECTRIC PUMPS FOR AIR CONDITIONING, REFRIGERATION, IRRIGATION, DECANTING, PRESSURISATION SYSTEMS, AND INDUSTRIAL APPLICATIONS

Pumped liquid temperature range: from -10 °C to +140 °C - Maximum ambient temperature: +40°C

= 2900 1/min

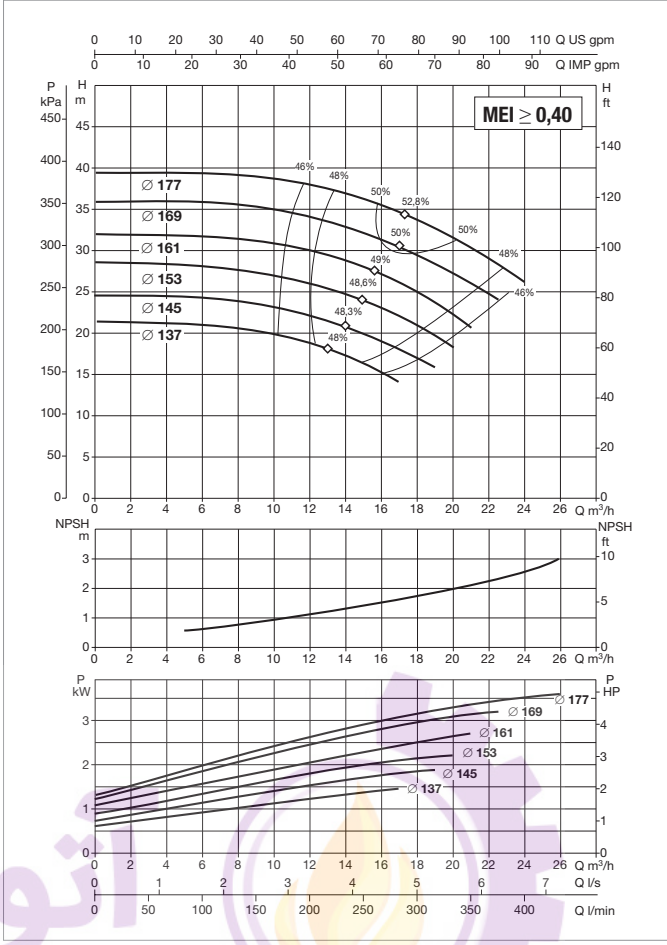
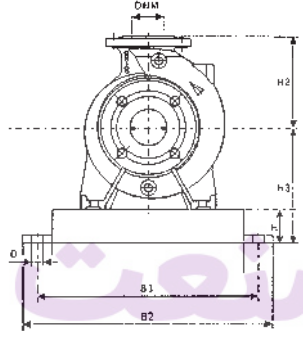
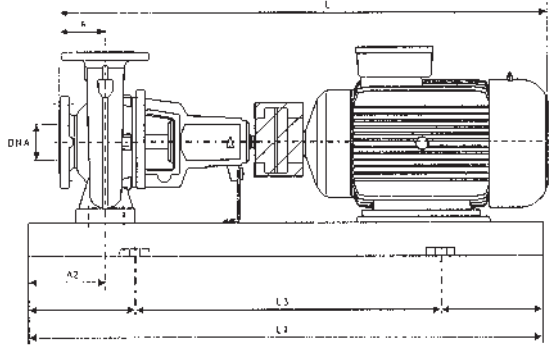

See hydraulic efficiency details on page 291.

The performance curves are based on kinematic viscosity values = 1 mm²/s and density equal to 1000 kg/m³. Curve tolerance according to ISO 9906.

MODEL	ELECTRICAL DATA					
	POWER (kW)	SIZE MOTOR	POWER INPUT 50 Hz	In A		TYPE MOTOR
	2 POLES			IE2	IE3	
KDN 32-160.1	1.1	MEC 80	3 x 230 - 400 V ~	4.07/2.36	-	IE2
	1.5	MEC 90S	3 x 230 - 400 V ~	5.80/3.35	-	IE2
	2.2	MEC 90L	3 x 230 - 400 V ~	8.23/4.75	-	IE2
	3	MEC 100L	3 - 400 V - Δ	5.85	-	IE2
	4	MEC 112M	3 - 400 V - Δ	8.05	-	IE2
	5.5	MEC 132S	3 - 400 V - Δ	10.4	-	IE2

MODEL	POWER (kW)	UNIT DIMENSIONS (mm)										FLANGE DIMENSIONS (mm)		STANDARD COUPLING				SPACER COUPLING				REF.
		A	A2	H2	H	H3	L1	L3	B2	B3	D	DNA	DNM	IE2		IE3		IE2		IE3		
		L	WEIGHT kg	L	WEIGHT kg	L	WEIGHT kg	L	WEIGHT kg	L	WEIGHT kg	L	WEIGHT kg	L	WEIGHT kg	L	WEIGHT kg	L	WEIGHT kg			
KDN 32-160.1	1.5	80	60	160	65	197	800	540	360	320	19	50	32	740	91	-	-	840	96	-	-	2
	1.5	80	60	160	65	197	800	540	360	320	19	50	32	765	94	-	-	865	99	-	-	2
	2.2	80	60	160	65	197	900	600	390	350	19	50	32	790	102	-	-	890	107	-	-	3
	3	80	60	160	65	197	900	600	390	350	19	50	32	830	102	-	-	930	107	-	-	3
	4	80	60	160	65	197	900	600	390	350	19	50	32	845	104	-	-	945	109	-	-	3
	5.5	80	60	160	80	212	1000	660	450	400	24	50	32	915	136	-	-	1015	141	-	-	4

Dimension and electrical data based on sizing definition following the instructions on page 96.



KDN 32-160 - 2 POLES - STANDARDISED CENTRIFUGAL ELECTRIC PUMPS FOR AIR CONDITIONING, REFRIGERATION, IRRIGATION, DECANTING, PRESSURISATION SYSTEMS, AND INDUSTRIAL APPLICATIONS

Pumped liquid temperature range: from -10 °C to +140 °C - Maximum ambient temperature: +40°C

= 2900 1/min

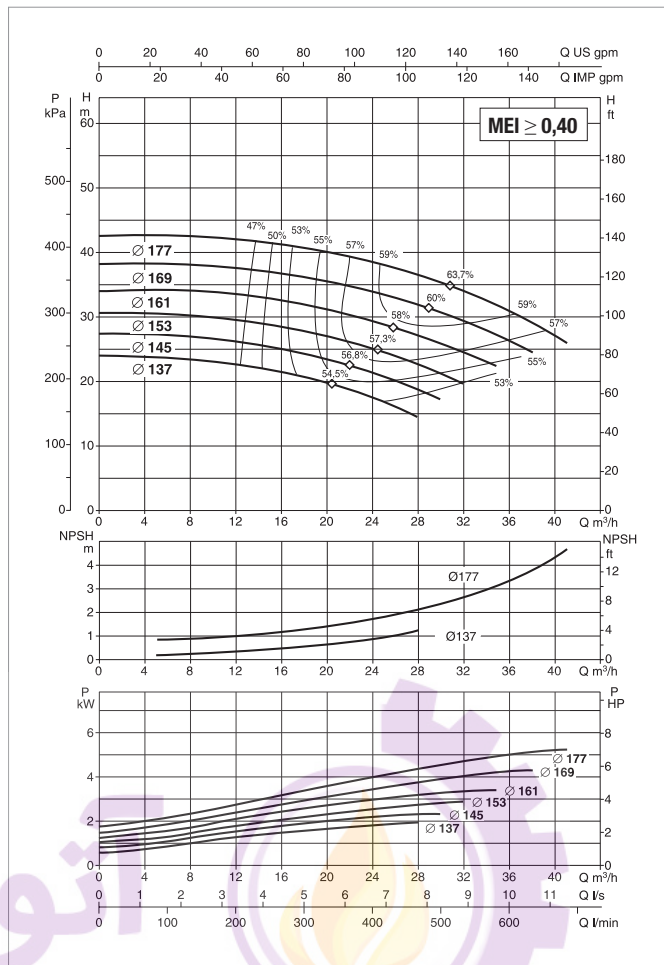
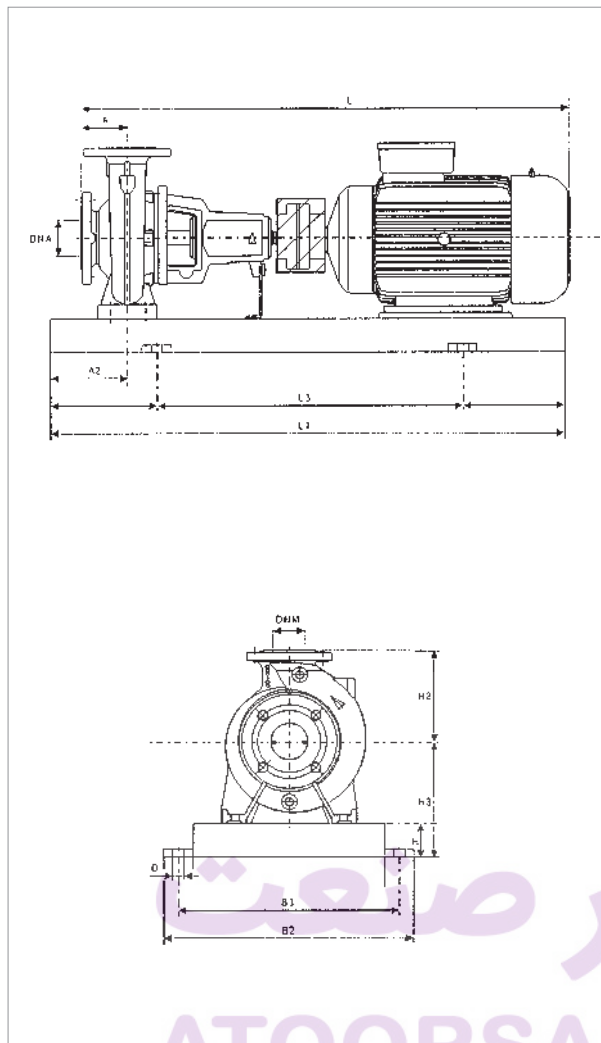

See hydraulic efficiency details on page 291.

The performance curves are based on kinematic viscosity values = 1 mm²/s and density equal to 1000 kg/m³. Curve tolerance according to ISO 9906.

MODEL	ELECTRICAL DATA					
	POWER (kW) 2 POLES	MOTOR SIZE	POWER INPUT 50 Hz	In A		MOTOR TYPE
				IE2	IE3	
KDN 32-160	2.2	MEC 90L	3 x 230 - 400 V ~	8.23/4.75	-	IE2
	3	MEC 100L	3 x 400 V - Δ	5.85	-	IE2
	4	MEC 112M	3 x 400 V - Δ	8.05	-	IE2
	5.5	MEC 132S	3 x 400 V - Δ	10.4	-	IE2
	7.5	MEC 132S	3 x 400 V - Δ	14	13.4	IE2 / IE3

MODEL	POWER (kW)	UNIT DIMENSIONS (mm)										FLANGE DIMENSIONS (mm)		STANDARD COUPLING				SPACER COUPLING				REF.
		A	A2	H2	H	H3	L1	L3	B2	B3	D	DNA	DNM	IE2		IE3		IE2		IE3		
														L	WEIGHT kg	L	WEIGHT kg	L	WEIGHT kg	L	WEIGHT kg	
KDN 32-160	2.2	80	60	160	65	197	900	600	390	350	19	50	32	790	92	-	-	97	100	-	-	3
	3	80	60	160	65	197	900	600	390	350	19	50	32	830	102	-	-	107	107	-	-	3
	4	80	60	160	65	197	900	600	390	350	19	50	32	845	104	-	-	109	109	-	-	3
	5.5	80	60	160	80	212	1000	660	450	400	24	50	32	915	136	-	-	141	141	-	-	4
	7.5	80	60	160	80	212	1000	660	450	400	24	50	32	915	139	925	113	1015	144	1025	118	4

Dimension and electrical data based on sizing definition following the instructions on page 96.

KDN 32-200.1 - 2 POLES - STANDARDISED CENTRIFUGAL ELECTRIC PUMPS FOR AIR CONDITIONING, REFRIGERATION, IRRIGATION, DECANTING, PRESSURISATION SYSTEMS, AND INDUSTRIAL APPLICATIONS

Pumped liquid temperature range: from -10 °C to +140 °C - Maximum ambient temperature: +40°C

= 2900 1/min

CENTRIFUGAL PUMPS

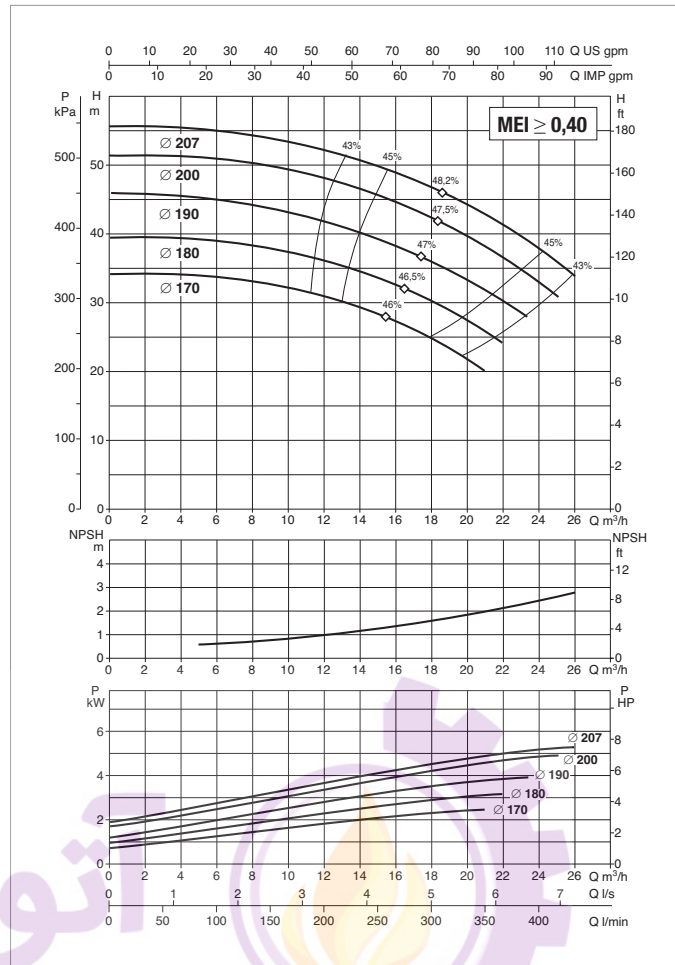
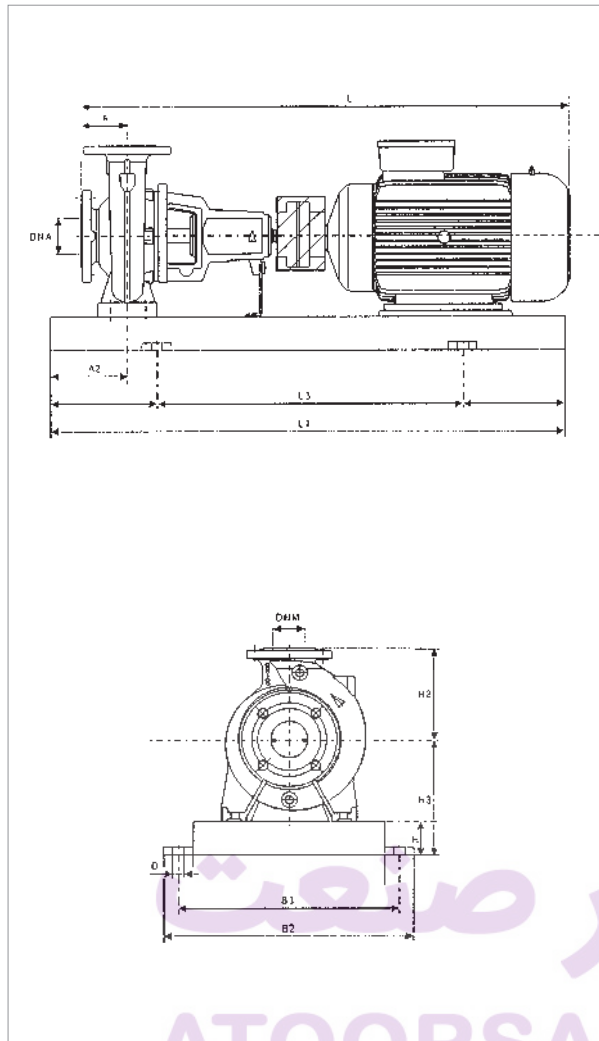

See hydraulic efficiency details on page 291.

The performance curves are based on kinematic viscosity values = 1 mm²/s and density equal to 1000 kg/m³. Curve tolerance according to ISO 9906.

MODEL	ELECTRICAL DATA					
	POWER (kW)	MOTOR SIZE	POWER INPUT 50 Hz	In A		MOTOR TYPE
				IE2	IE3	
KDN 32-200.1	2.2	MEC 90L	3 x 230 - 400 V ~	8.23/4.75	-	IE2
	3	MEC 100L	3 x 400 V - Δ	5.85	-	IE2
	4	MEC 112M	3 x 400 V - Δ	8.05	-	IE2
	5.5	MEC 132S	3 x 400 V - Δ	10.4	-	IE2
	7.5	MEC 132S	3 x 400 V - Δ	14	13.4	IE2 / IE3

MODEL	POWER (kW)	UNIT DIMENSIONS (mm)										FLANGE DIMENSIONS (mm)		STANDARD COUPLING				SPACER COUPLING				REF.
		A	A2	H2	H	H3	L1	L3	B2	B3	D	DNA	DNM	IE2		IE3		IE2		IE3		
														L	WEIGHT kg	L	WEIGHT kg	L	WEIGHT kg	L	WEIGHT kg	
KDN 32-200.1	2.2	80	60	180	65	225	900	600	390	350	19	50	32	790	108	-	-	890	113	-	-	3
	3	80	60	180	65	225	900	600	390	350	19	50	32	830	140	-	-	930	145	-	-	3
	4	80	60	180	65	225	900	600	390	350	19	50	32	845	143	-	-	945	148	-	-	3
	5.5	80	60	180	80	240	1000	660	450	400	24	50	32	915	143	-	-	1015	148	-	-	4
	7.5	80	60	180	80	240	1000	660	450	400	24	50	32	915	166	925	140	1015	171	1025	145	4

Dimension and electrical data based on sizing definition following the instructions on page 96.

KDN 32-200 - 2 POLES - STANDARDISED CENTRIFUGAL ELECTRIC PUMPS FOR AIR CONDITIONING, REFRIGERATION, IRRIGATION, DECANTING, PRESSURISATION SYSTEMS, AND INDUSTRIAL APPLICATIONS

Pumped liquid temperature range: from -10 °C to +140 °C - Maximum ambient temperature: +40°C

= 2900 1/min

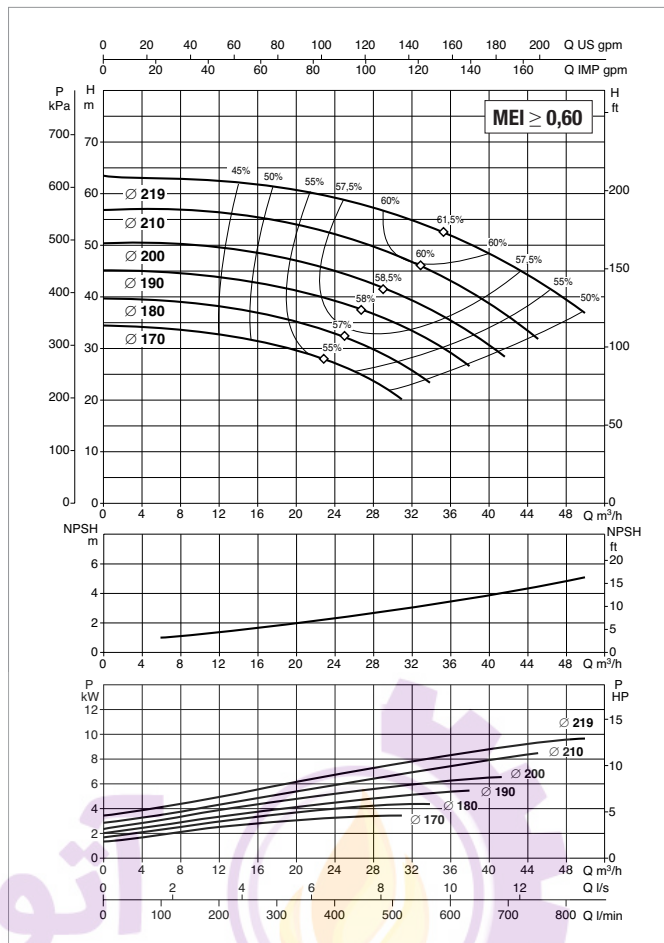
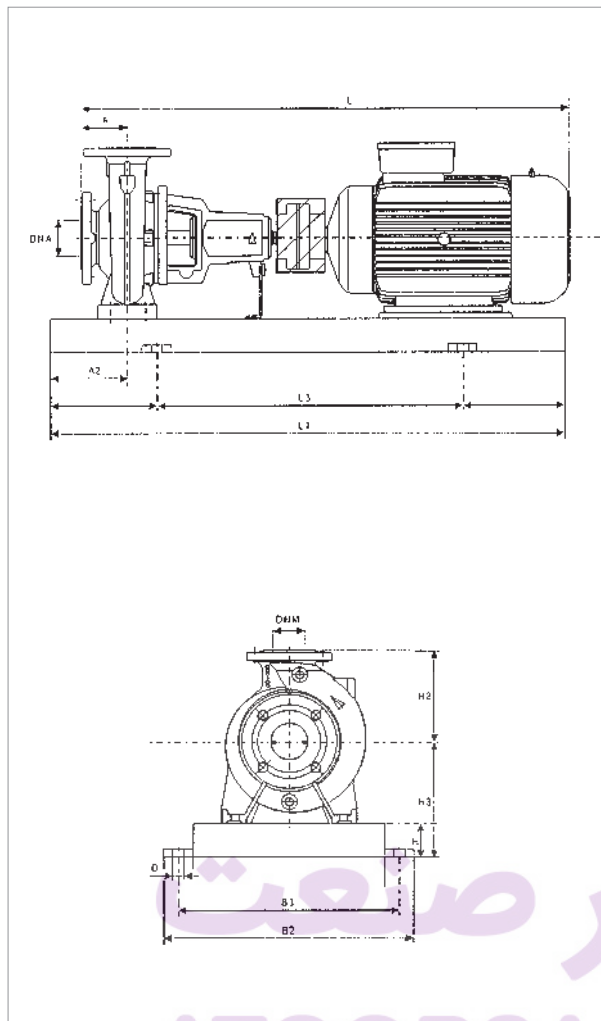

See hydraulic efficiency details on page 291.

The performance curves are based on kinematic viscosity values = 1 mm²/s and density equal to 1000 kg/m³. Curve tolerance according to ISO 9906.

MODEL	ELECTRICAL DATA					
	POWER (kW)	MOTOR SIZE	POWER INPUT 50 Hz	In A		MOTOR TYPE
	2 POLES			IE2	IE3	
KDN 32-200	3	MEC 100L	3 x 400 V - Δ	5.85	-	IE3
	4	MEC 112M	3 x 400 V - Δ	8.05	-	IE3
	5.5	MEC 132S	3 x 400 V - Δ	10.4	-	IE3
	7.5	MEC 132S	3 x 400 V - Δ	14	13.4	IE2 / IE3
	11	MEC 160M	3 x 400 V - Δ	20.2	19.4	IE2 / IE3
	15	MEC 160M	3 x 400 V - Δ	27	26.5	IE2 / IE3

MODEL	POWER (kW)	UNIT DIMENSIONS (mm)										FLANGE DIMENSIONS (mm)		STANDARD COUPLING		SPACER COUPLING				REF.		
		A	A2	H2	H	H3	L1	L3	B2	B3	D	DNA	DNM	IE2		IE3		IE2			IE3	
		L	WEIGHT kg	L	WEIGHT kg	L	WEIGHT kg	L	WEIGHT kg	L	WEIGHT kg	L	WEIGHT kg	L	WEIGHT kg	L	WEIGHT kg	L	WEIGHT kg			
KDN 32-200	3	80	60	180	65	225	900	600	390	350	19	50	32	830	103	-	-	930	108	-	-	3
	4	80	60	180	65	225	900	600	390	350	19	50	32	845	104	-	-	945	109	-	-	3
	5.5	80	60	180	80	240	1000	660	450	400	24	50	32	915	143	-	-	1015	148	-	-	4
	7.5	80	60	180	80	240	1000	660	450	400	24	50	32	915	177	925	151	1015	182	1025	156	4
	11	80	60	180	80	240	1120	740	490	440	24	50	32	1060	237	1060	214	1160	242	1160	219	5
	15	80	60	180	80	240	1120	740	490	440	24	50	32	1060	248	1060	221	1160	253	1160	226	5

Dimension and electrical data based on sizing definition following the instructions on page 96.

KDN 40-125 - 2 POLES - STANDARDISED CENTRIFUGAL ELECTRIC PUMPS FOR AIR CONDITIONING, REFRIGERATION, IRRIGATION, DECANTING, PRESSURISATION SYSTEMS, AND INDUSTRIAL APPLICATIONS

Pumped liquid temperature range: from -10 °C to +140 °C - Maximum ambient temperature: +40°C

= 2900 1/min

CENTRIFUGAL PUMPS

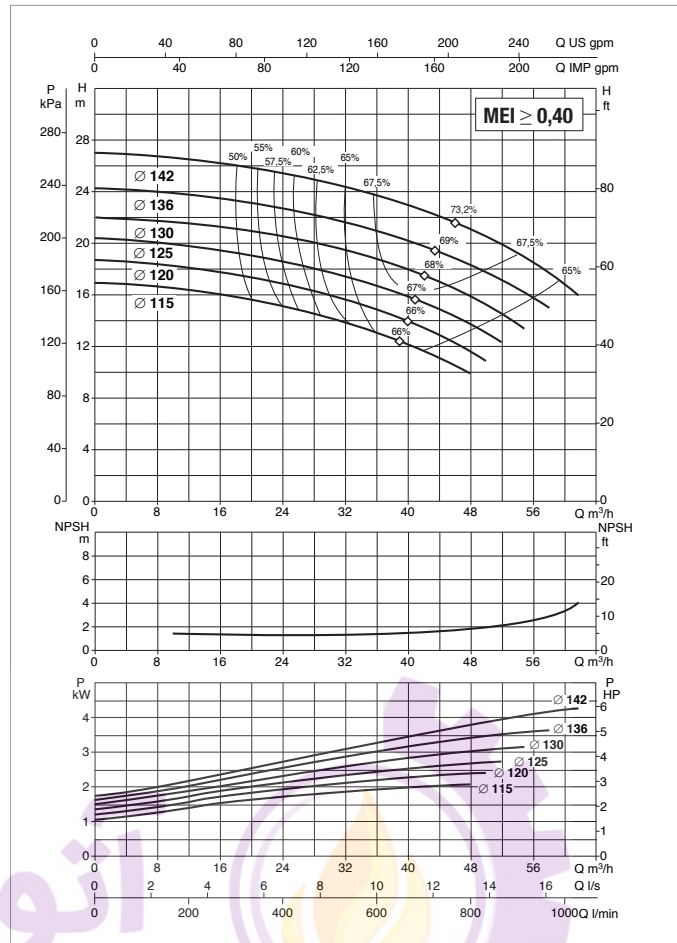
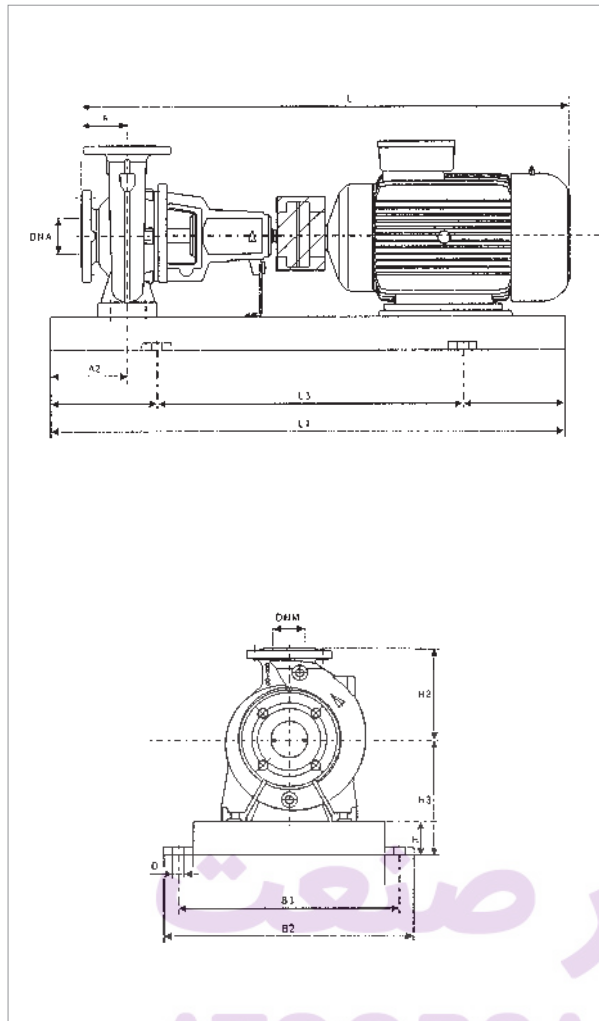

See hydraulic efficiency details on page 291.

The performance curves are based on kinematic viscosity values = 1 mm²/s and density equal to 1000 kg/m³. Curve tolerance according to ISO 9906.

MODEL	ELECTRICAL DATA					
	POWER (kW) 2 POLES	MOTOR SIZE	POWER INPUT 50 Hz	In A		MOTOR TYPE
				IE2	IE3	
KDN 40-125	1.5	MEC 90S	3 x 230 - 400 V ~	5.80/3.35	-	IE2
	2.2	MEC 90L	3 x 230 - 400 V ~	8.23/4.75	-	IE2
	3	MEC 100L	3 x 400 V - Δ	5.85	-	IE2
	4	MEC 112M	3 x 400 V - Δ	8.05	-	IE2
	5.5	MEC 132S	3 x 400 V - Δ	10.4	-	IE2
	7.5	MEC 132S	3 x 400 V - Δ	14	13.4	IE2 / IE3

MODEL	POWER (kW)	UNIT DIMENSIONS (mm)										FLANGE DIMENSIONS (mm)		STANDARD COUPLING				SPACER COUPLING				REF.
		A	A2	H2	H	H3	L1	L3	B2	B3	D	DNA	DNM	IE2		IE3		IE2		IE3		
		L	WEIGHT kg	L	WEIGHT kg	L	WEIGHT kg	L	WEIGHT kg	L	WEIGHT kg	L	WEIGHT kg	L	WEIGHT kg	L	WEIGHT kg	L	WEIGHT kg			
KDN 40-125	1.5	80	60	140	65	177	800	540	360	320	19	65	40	765	86	-	-	865	91	-	-	2
	2.2	80	60	140	65	177	900	600	390	350	19	65	40	790	91	-	-	890	96	-	-	3
	3	80	60	140	65	177	900	600	390	350	19	65	40	830	91	-	-	930	96	-	-	3
	4	80	60	140	65	177	900	600	390	350	19	65	40	845	102	-	-	945	107	-	-	3
	5.5	80	60	140	80	212	1000	660	450	400	24	65	40	915	134	-	-	1015	139	-	-	4
	7.5	80	60	140	80	212	1000	600	450	400	24	65	40	915	137	925	111	1015	142	1025	116	4

Dimension and electrical data based on sizing definition following the instructions on page 96.

KDN 40-160 - 2 POLES - STANDARDISED CENTRIFUGAL ELECTRIC PUMPS FOR AIR CONDITIONING, REFRIGERATION, IRRIGATION, DECANTING, PRESSURISATION SYSTEMS, AND INDUSTRIAL APPLICATIONS

Pumped liquid temperature range: from -10 °C to +140 °C - Maximum ambient temperature: +40°C

= 2900 1/min

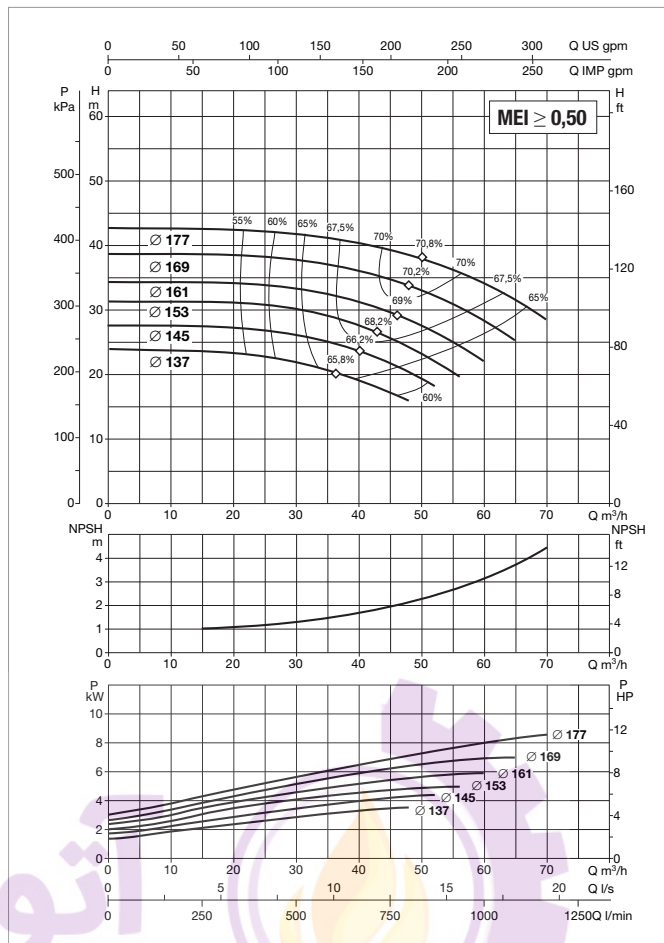
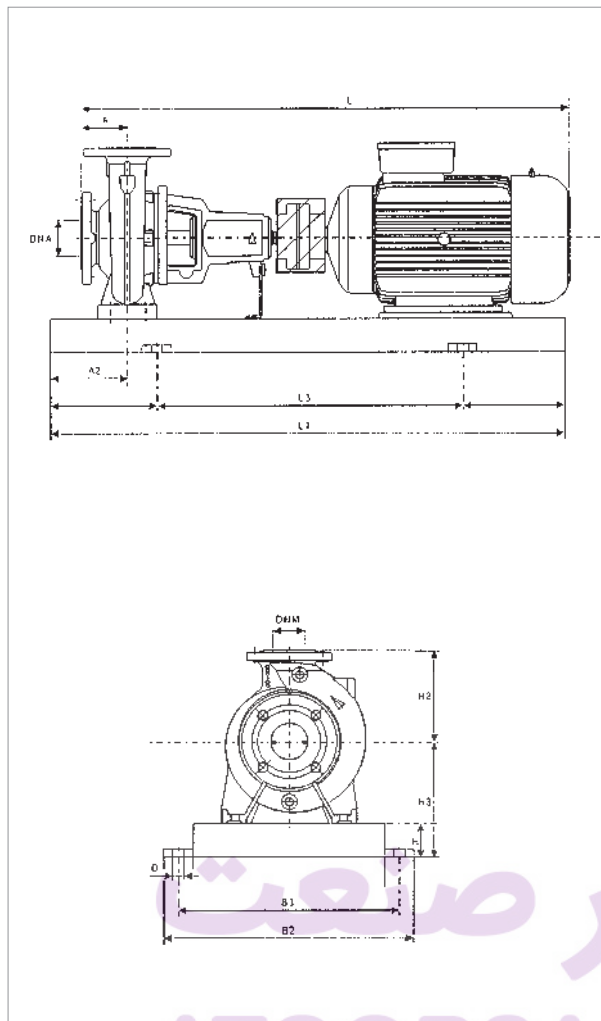

See hydraulic efficiency details on page 291.

The performance curves are based on kinematic viscosity values = 1 mm²/s and density equal to 1000 kg/m³. Curve tolerance according to ISO 9906.

MODEL	ELECTRICAL DATA					
	POWER (kW) 2 POLES	MOTOR SIZE	POWER INPUT 50 Hz	In A		MOTOR TYPE
				IE2	IE3	
KDN 40-160	3	MEC 100L	3 x 400 V - Δ	5.85	-	IE2
	4	MEC 112M	3 x 400 V - Δ	8.05	-	IE2
	5.5	MEC 132S	3 x 400 V - Δ	10.4	-	IE2
	7.5	MEC 132S	3 x 400 V - Δ	14	13.4	IE2 / IE3
	11	MEC 160M	3 x 400 V - Δ	20.2	19.4	IE2 / IE3
	15	MEC 160M	3 x 400 V - Δ	27	26.5	IE2 / IE3

MODEL	POWER (kW)	UNIT DIMENSIONS (mm)										FLANGE DIMENSIONS (mm)		STANDARD COUPLING				SPACER COUPLING				REF.
		A	A2	H2	H	H3	L1	L3	B2	B3	D	DNA	DNM	IE2		IE3		IE2		IE3		
		L	WEIGHT kg	L	WEIGHT kg	L	WEIGHT kg	L	WEIGHT kg	L	WEIGHT kg	L	WEIGHT kg	L	WEIGHT kg	L	WEIGHT kg	L	WEIGHT kg			
KDN 40-160	3	80	60	160	65	197	900	600	390	350	19	65	40	826	102	-	-	930	107	-	-	3
	4	80	60	160	65	197	900	600	390	350	19	65	40	846	104	-	-	945	109	-	-	3
	5.5	80	60	160	80	212	1000	660	450	400	24	65	40	959	160	-	-	1015	165	-	-	4
	7.5	80	60	160	80	212	1000	660	450	400	24	65	40	915	165	925	139	1015	170	1025	144	4
	11	80	60	160	80	240	1120	740	490	440	24	65	40	1060	173	1060	150	1160	178	1160	155	5
	15	80	60	160	80	240	1120	740	490	440	24	65	40	1060	173	1060	146	1160	178	1160	151	5

Dimension and electrical data based on sizing definition following the instructions on page 96.

KDN 40-200 - 2 POLES - STANDARDISED CENTRIFUGAL ELECTRIC PUMPS FOR AIR CONDITIONING, REFRIGERATION, IRRIGATION, DECANTING, PRESSURISATION SYSTEMS, AND INDUSTRIAL APPLICATIONS

Pumped liquid temperature range: from -10 °C to +140 °C - Maximum ambient temperature: +40°C

= 2900 1/min

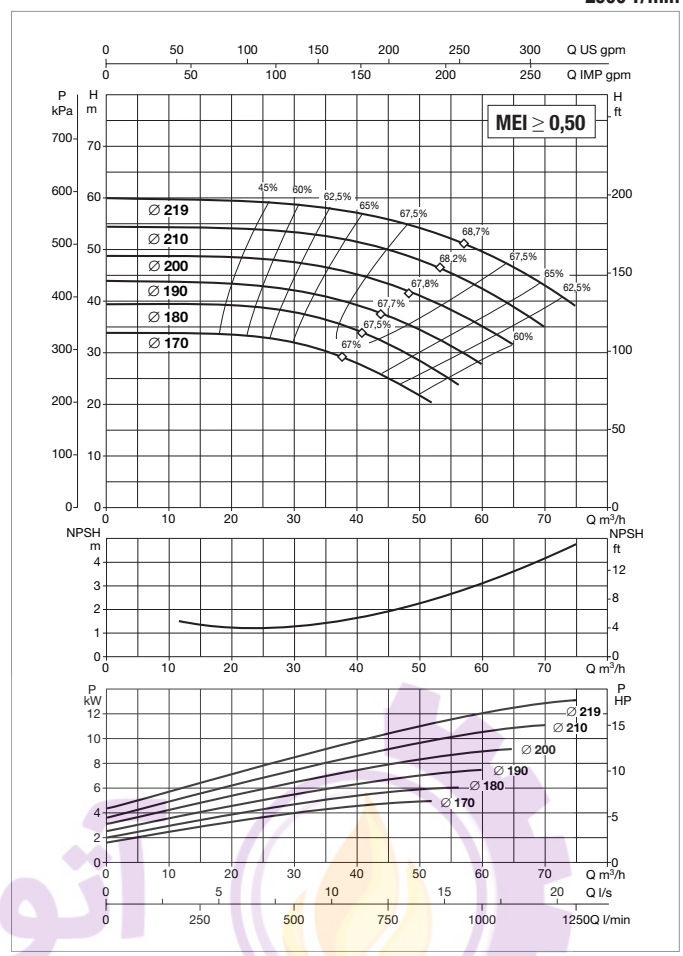
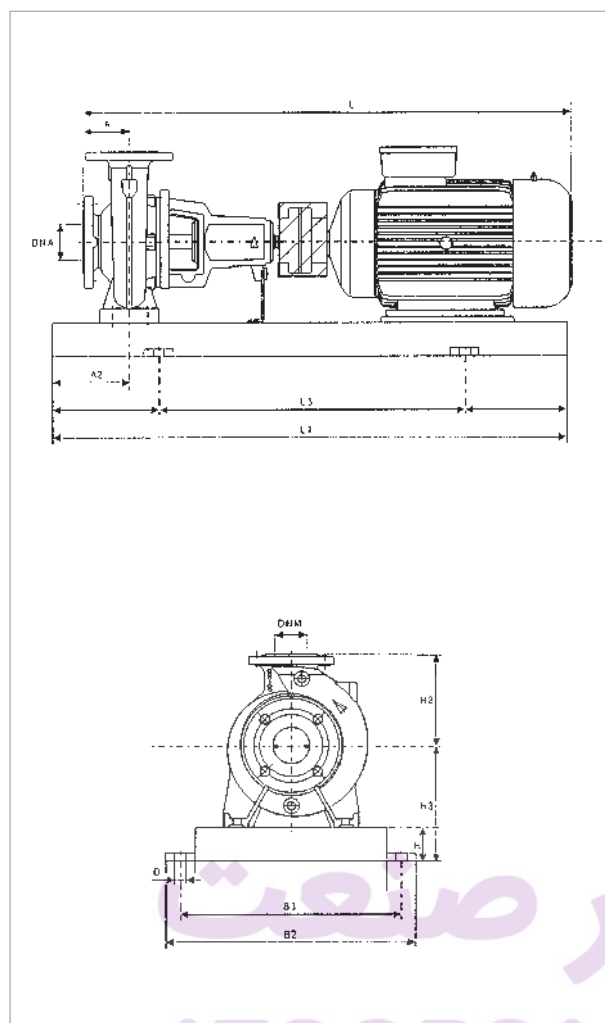

See hydraulic efficiency details on page 291.

The performance curves are based on kinematic viscosity values = 1 mm²/s and density equal to 1000 kg/m³. Curve tolerance according to ISO 9906.

MODEL	ELECTRICAL DATA					
	POWER (kW) 2 POLES	MOTOR SIZE	POWER INPUT 50 Hz	In A		MOTOR TYPE
				IE2	IE3	
KDN 40-200	4	MEC 112M	3 x 400 V - Δ	8.05	-	IE2
	5.5	MEC 132S	3 x 400 V - Δ	10.4	-	IE2
	7.5	MEC 132S	3 x 400 V - Δ	14	13.4	IE2 / IE3
	11	MEC 160M	3 x 400 V - Δ	20.2	19.4	IE2 / IE3
	15	MEC 160M	3 x 400 V - Δ	27	26.5	IE2 / IE3
	18.5	MEC 160L	3 x 400 V - Δ	33	32	IE2 / IE3

MODEL	POWER (kW)	UNIT DIMENSIONS (mm)										FLANGE DIMENSIONS (mm)		STANDARD COUPLING				SPACER COUPLING				REF.
		A	A2	H2	H	H3	L1	L3	B2	B3	D	DNA	DNM	IE2		IE3		IE2		IE3		
		L	WEIGHT kg	L	WEIGHT kg	L	WEIGHT kg	L	WEIGHT kg	L	WEIGHT kg	L	WEIGHT kg	L	WEIGHT kg	L	WEIGHT kg	L	WEIGHT kg			
KDN 40-200	4	100	60	180	65	225	900	600	390	350	19	65	40	865	135	-	-	965	140	-	-	3
	5.5	100	60	180	80	240	1000	660	450	400	24	65	40	935	146	-	-	1035	151	-	-	4
	7.5	100	60	180	80	240	1000	660	450	400	24	65	40	935	147	945	121	1035	152	1045	126	4
	11	100	60	180	80	240	1120	740	490	440	24	65	40	1080	221	1080	198	1180	226	1180	203	5
	15	100	60	180	80	240	1120	740	490	440	24	65	40	1080	231	1080	204	1180	236	1180	209	5
	18.5	100	60	180	80	240	1120	740	490	440	24	65	40	1135	231	1123	199	1235	236	1223	204	5

Dimension and electrical data based on sizing definition following the instructions on page 96.



KDN 40-250 - 2 POLES - STANDARDISED CENTRIFUGAL ELECTRIC PUMPS FOR AIR CONDITIONING, REFRIGERATION, IRRIGATION, DECANTING, PRESSURISATION SYSTEMS, AND INDUSTRIAL APPLICATIONS

Pumped liquid temperature range: from -10 °C to +140 °C - Maximum ambient temperature: +40°C

= 2900 1/min

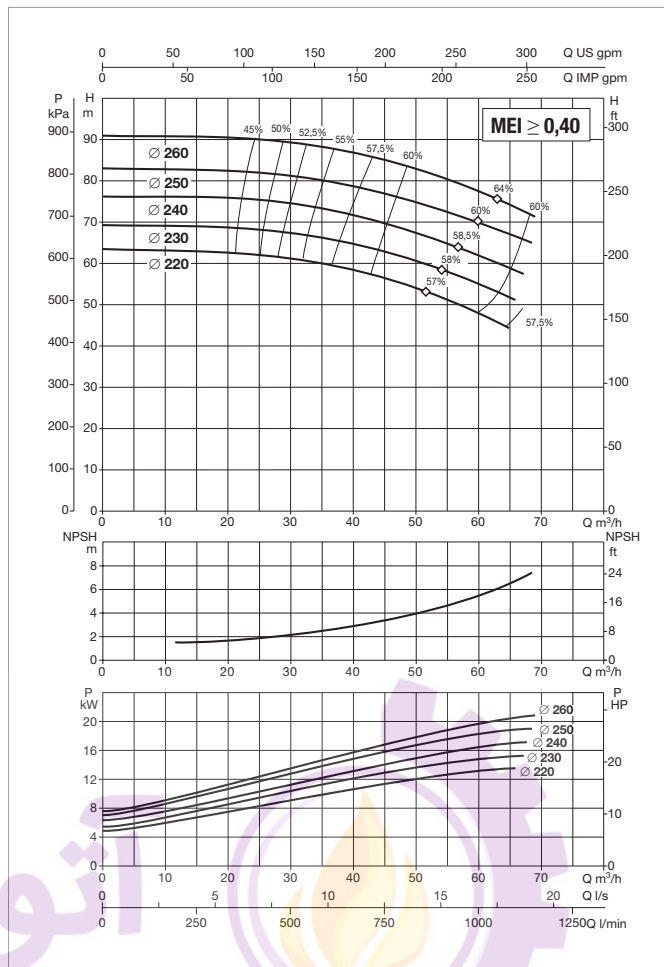
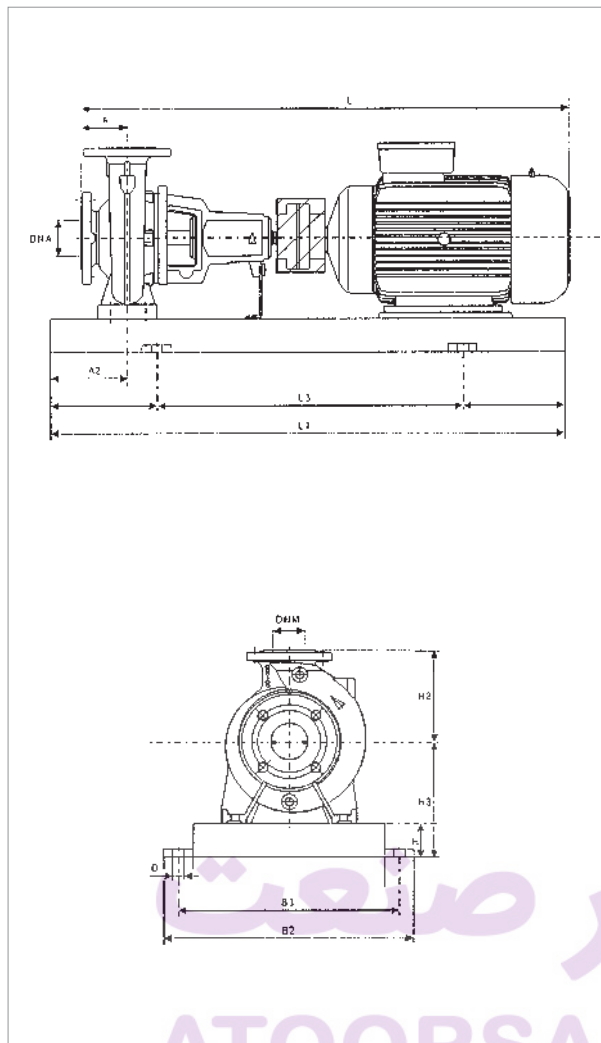

See hydraulic efficiency details on page 291.

The performance curves are based on kinematic viscosity values = 1 mm²/s and density equal to 1000 kg/m³. Curve tolerance according to ISO 9906.

MODEL	ELECTRICAL DATA					
	POWER (kW) 2 POLES	MOTOR SIZE	POWER INPUT 50 Hz	In A		MOTOR TYPE
				IE2	IE3	
KDN 40-250	11	MEC 160M	3 x 400 V - Δ	20.2	19.4	IE2 / IE3
	15	MEC 160M	3 x 400 V - Δ	27	26.5	IE2 / IE3
	18.5	MEC 160L	3 x 400 V - Δ	33	32	IE2 / IE3
	22	MEC 180M	3 x 400 V - Δ	39.5	38	IE2 / IE3
	30	MEC 200L	3 x 400 V - Δ	52	52	IE2 / IE3

MODEL	POWER (kW)	UNIT DIMENSIONS (mm)										FLANGE DIMENSIONS (mm)		STANDARD COUPLING				SPACER COUPLING				REF.
		A	A2	H2	H	H3	L1	L3	B2	B3	D	DNA	DNM	IE2		IE3		IE2		IE3		
														L	WEIGHT kg	L	WEIGHT kg	L	WEIGHT kg	L	WEIGHT kg	
KDN 40-250	11	100	75	225	80	260	1250	840	540	490	24	65	40	1080	236	1080	213	1180	241	1180	218	6
	15	100	75	225	80	260	1250	840	540	490	24	65	40	1080	278	1080	251	1180	283	1180	256	6
	18.5	100	75	225	80	260	1250	840	540	490	24	65	40	1135	298	1123	266	1235	303	1223	271	6
	22	100	75	225	80	260	1250	840	540	490	24	65	40	1155	320	1155	278	1255	325	1255	283	6
	30	100	75	225	100	300	1400	940	610	550	28	65	40	1235	320	1245	332	1335	325	1345	337	7

Dimension and electrical data based on sizing definition following the instructions on page 96.

KDN 50-125 - 2 POLES - STANDARDISED CENTRIFUGAL ELECTRIC PUMPS FOR AIR CONDITIONING, REFRIGERATION, IRRIGATION, DECANTING, PRESSURISATION SYSTEMS, AND INDUSTRIAL APPLICATIONS

Pumped liquid temperature range: from -10 °C to +140 °C - Maximum ambient temperature: +40°C

= 2900 1/min

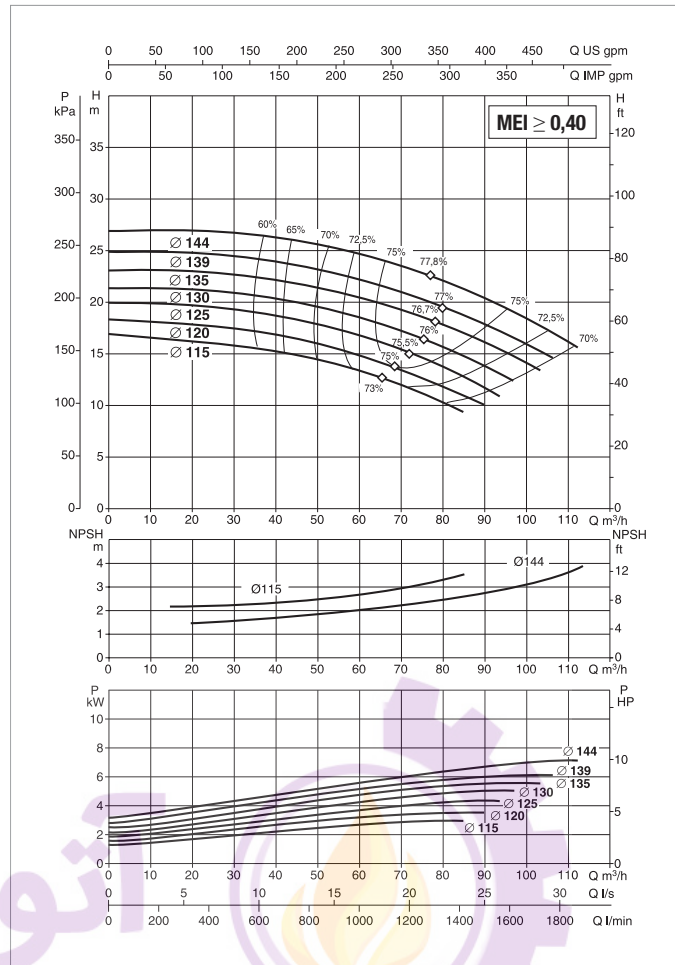
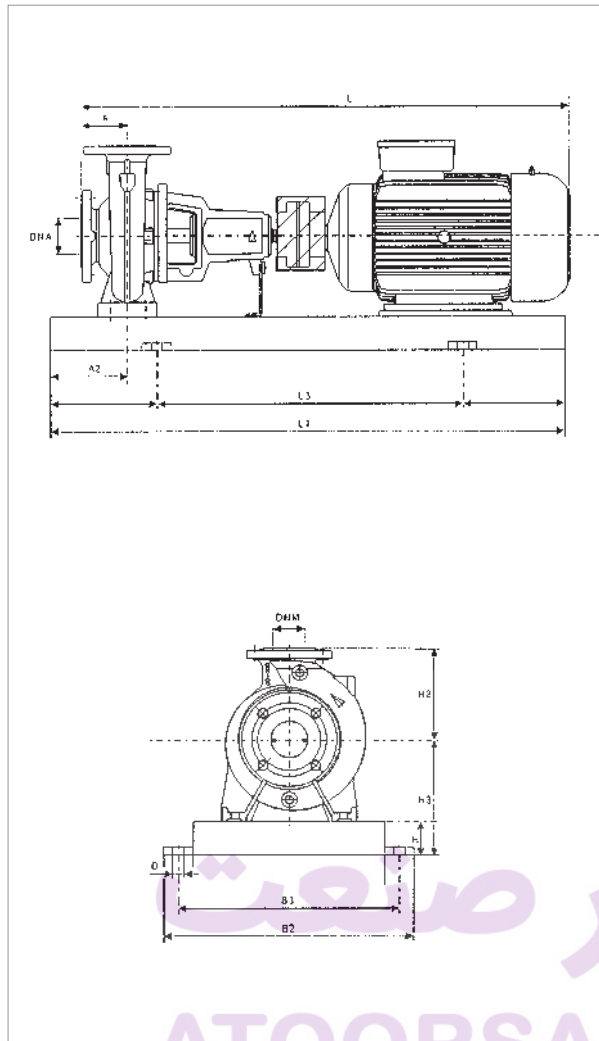

See hydraulic efficiency details on page 291.

The performance curves are based on kinematic viscosity values = 1 mm²/s and density equal to 1000 kg/m³. Curve tolerance according to ISO 9906.

MODEL	ELECTRICAL DATA					
	POWER (kW) 2 POLES	MOTOR SIZE	POWER INPUT 50 Hz	In A		MOTOR TYPE
				IE2	IE3	
KDN 50-125	3	MEC 100L	3 x 400 V - Δ	5.85	-	IE2
	4	MEC 112M	3 x 400 V - Δ	8.05	-	IE2
	5.5	MEC 132S	3 x 400 V - Δ	10.4	-	IE2
	7.5	MEC 132S	3 x 400 V - Δ	14	13.4	IE2 / IE3
	11	MEC 160M	3 x 400 V - Δ	20.2	19.4	IE2 / IE3

MODEL	POWER (kW)	UNIT DIMENSIONS (mm)										FLANGE DIMENSIONS (mm)		STANDARD COUPLING				SPACER COUPLING				REF.
		A	A2	H2	H	H3	L1	L3	B2	B3	D	DNA	DNM	IE2		IE3		IE2		IE3		
		L	WEIGHT kg	L	WEIGHT kg	L	WEIGHT kg	L	WEIGHT kg	L	WEIGHT kg											
KDN 50-125	3	100	60	160	65	197	900	600	390	350	19	65	50	850	105	-	-	950	110	-	-	3
	4	100	60	160	65	197	900	600	390	350	19	65	50	865	109	-	-	965	114	-	-	3
	5.5	100	60	160	80	212	1000	660	450	400	24	65	50	935	143	-	-	1035	148	-	-	4
	7.5	100	60	160	80	212	1000	660	450	400	24	65	50	935	143	945	117	1035	148	1045	122	4
	11	100	60	160	80	240	1120	740	490	400	24	65	50	1080	143	1080	120	1180	148	1180	125	5

Dimension and electrical data based on sizing definition following the instructions on page 96.

KDN 50-160 - 2 POLES - STANDARDISED CENTRIFUGAL ELECTRIC PUMPS FOR AIR CONDITIONING, REFRIGERATION, IRRIGATION, DECANTING, PRESSURISATION SYSTEMS, AND INDUSTRIAL APPLICATIONS

Pumped liquid temperature range: from -10 °C to +140 °C - Maximum ambient temperature: +40°C

= 2900 1/min

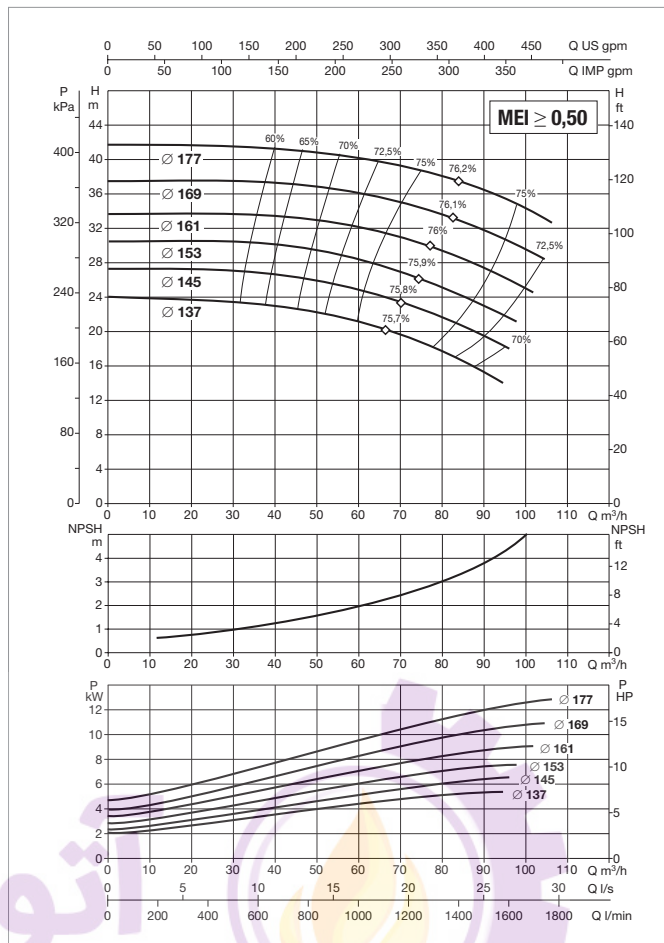
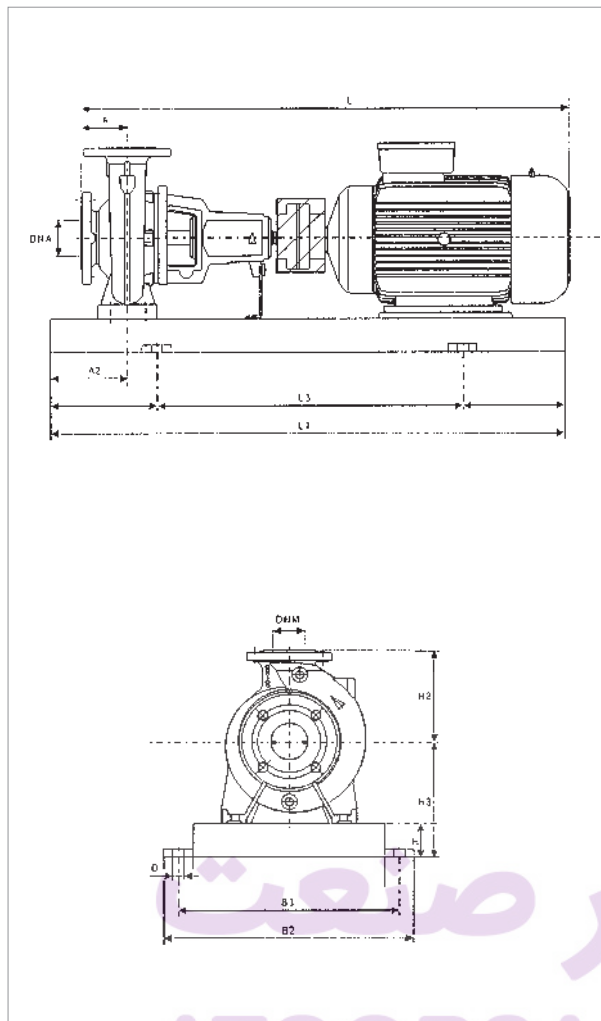

See hydraulic efficiency details on page 291.

The performance curves are based on kinematic viscosity values = 1 mm²/s and density equal to 1000 kg/m³. Curve tolerance according to ISO 9906.

MODEL	ELECTRICAL DATA					
	POWER (kW)	MOTOR SIZE	POWER INPUT 50 Hz	In A		MOTOR TYPE
	2 POLES			IE2	IE2	
KDN 50-160	4	MEC 112M	3 x 400 V - Δ	8.05	-	IE2
	5.5	MEC 132S	3 x 400 V - Δ	10.4	-	IE2
	7.5	MEC 132S	3 x 400 V - Δ	14	13.4	IE2 / IE3
	11	MEC 160M	3 x 400 V - Δ	20.2	19.4	IE2 / IE3
	15	MEC 160M	3 x 400 V - Δ	27	26.5	IE2 / IE3
	18.5	MEC 160L	3 x 400 V - Δ	33	32	IE2 / IE3

MODEL	POWER (kW)	UNIT DIMENSIONS (mm)										FLANGE DIMENSIONS (mm)		STANDARD COUPLING				SPACER COUPLING				REF.
		A	A2	H2	H	H3	L1	L3	B2	B3	D	DNA	DNM	IE2		IE3		IE2		IE3		
		L	WEIGHT kg	L	WEIGHT kg	L	WEIGHT kg	L	WEIGHT kg	L	WEIGHT kg	L	WEIGHT kg	L	WEIGHT kg	L	WEIGHT kg	L	WEIGHT kg			
KDN 50-160	4	100	60	180	65	225	900	600	390	350	19	65	50	865	132	-	-	965	137	-	-	3
	5.5	100	60	180	80	240	1000	660	450	400	24	65	50	935	143	-	-	1035	148	-	-	4
	7.5	100	60	180	80	240	1000	660	450	400	24	65	50	935	177	945	151	1035	182	1045	156	4
	11	100	60	180	80	240	1120	740	490	440	24	65	50	1080	188	1080	165	1180	193	1180	170	5
	15	100	60	180	80	240	1120	740	490	440	24	65	50	1080	200	1080	173	1180	205	1180	178	5
	18.5	100	60	180	80	240	1120	740	490	440	24	65	50	1135	202	1123	170	1235	207	1223	175	5

Dimension and electrical data based on sizing definition following the instructions on page 96.

KDN 50-200 - 2 POLES - STANDARDISED CENTRIFUGAL ELECTRIC PUMPS FOR AIR CONDITIONING, REFRIGERATION, IRRIGATION, DECANTING, PRESSURISATION SYSTEMS, AND INDUSTRIAL APPLICATIONS

Pumped liquid temperature range: from -10 °C to +140 °C - Maximum ambient temperature: +40°C

= 2900 1/min

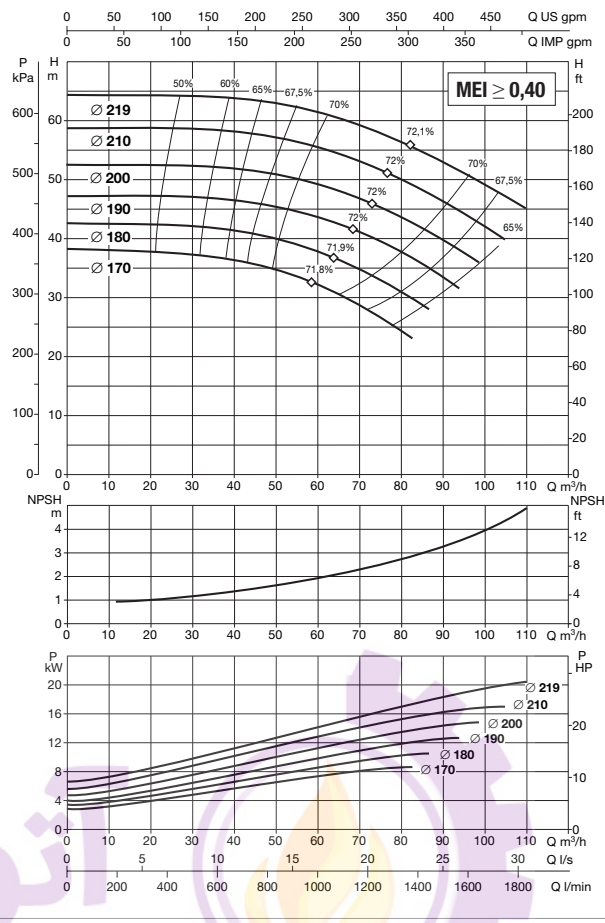
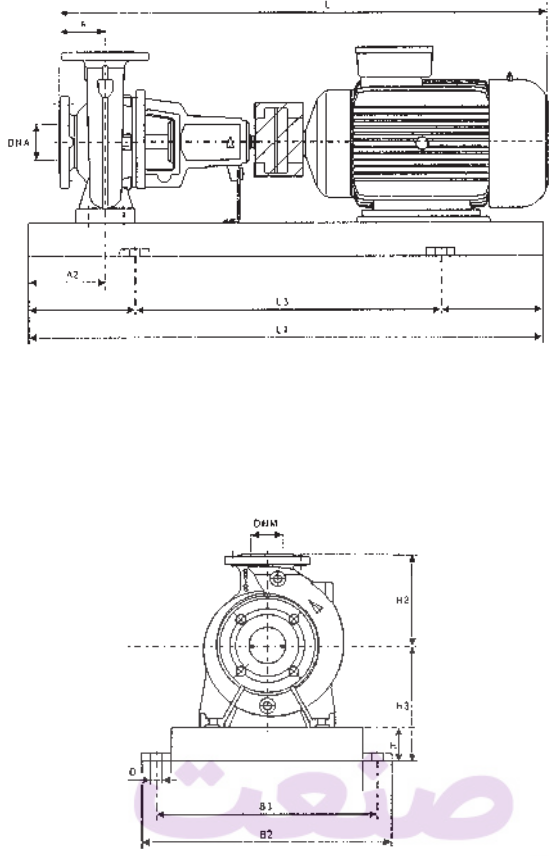

See hydraulic efficiency details on page 291.

The performance curves are based on kinematic viscosity values = 1 mm²/s and density equal to 1000 kg/m³. Curve tolerance according to ISO 9906.

MODEL	ELECTRICAL DATA					
	POWER (kW)	MOTOR SIZE	POWER INPUT 50 Hz	In A		MOTOR TYPE
	2 POLES			IE2	IE3	
KDN 50-200	7.5	MEC 132S	3 x 400 V - Δ	14	13.4	IE2 / IE3
	11	MEC 160M	3 x 400 V - Δ	20.2	19.4	IE2 / IE3
	15	MEC 160M	3 x 400 V - Δ	27	26.5	IE2 / IE3
	18.5	MEC 160L	3 x 400 V - Δ	33	32	IE2 / IE3
	22	MEC 180M	3 x 400 V - Δ	39.5	38	IE2 / IE3
	30	MEC 200L	3 x 400 V - Δ	52	52	IE2 / IE3

MODEL	POWER (kW)	UNIT DIMENSIONS (mm)										FLANGE DIMENSIONS (mm)		STANDARD COUPLING				SPACER COUPLING				REF.
		A	A2	H2	H	H3	L1	L3	B2	B3	D	DNA	DNM	IE2		IE3		IE2		IE3		
		L	WEIGHT kg	L	WEIGHT kg	L	WEIGHT kg	L	WEIGHT kg	L	WEIGHT kg	L	WEIGHT kg	L	WEIGHT kg	L	WEIGHT kg	L	WEIGHT kg			
KDN 50-200	7.5	100	60	200	80	240	1000	600	450	400	24	65	50	935	176	945	150	1035	181	1045	155	4
	11	100	60	200	80	240	1120	740	490	440	24	65	50	1080	186	1080	163	1180	191	1180	168	5
	15	100	60	200	80	240	1120	740	490	400	24	65	50	1080	280	1080	253	1180	285	1180	258	5
	18.5	100	60	200	80	240	1120	740	490	440	24	65	50	1135	283	1123	251	1235	288	1223	256	5
	22	100	60	200	80	260	1120	740	490	440	24	65	50	1155	290	1155	248	1255	295	1255	253	5
	30	100	60	200	80	280	1250	840	540	490	24	65	50	1235	290	1245	302	1335	295	1345	307	6

Dimension and electrical data based on sizing definition following the instructions on page 96.

KDN 50-250 - 2 POLES - STANDARDISED CENTRIFUGAL ELECTRIC PUMPS FOR AIR CONDITIONING, REFRIGERATION, IRRIGATION, DECANTING, PRESSURISATION SYSTEMS, AND INDUSTRIAL APPLICATIONS

Pumped liquid temperature range: from -10 °C to +140 °C - Maximum ambient temperature: +40°C

= 2900 1/min

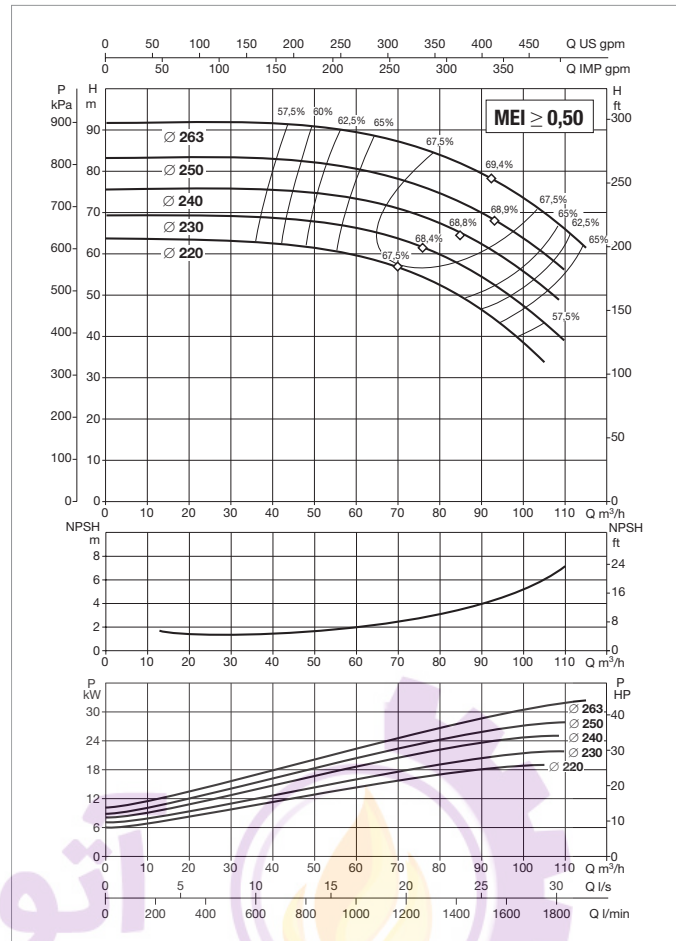
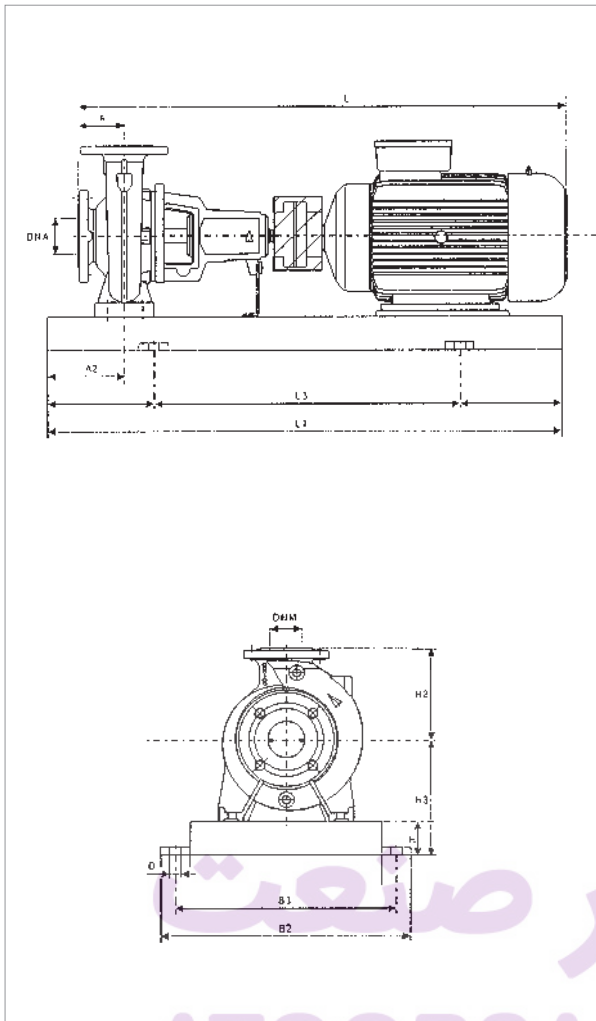

See hydraulic efficiency details on page 291.

The performance curves are based on kinematic viscosity values = 1 mm²/s and density equal to 1000 kg/m³. Curve tolerance according to ISO 9906.

MODEL	ELECTRICAL DATA					
	POWER (kW)	MOTOR SIZE	POWER INPUT 50 Hz	In A		MOTOR TYPE
	2 POLES			IE2	IE3	
KDN 50-250	15	MEC 160M	3 x 400 V - Δ	27	26.5	IE2 / IE3
	18.5	MEC 160L	3 x 400 V - Δ	33	32	IE2 / IE3
	22	MEC 180M	3 x 400 V - Δ	39.5	38	IE2 / IE3
	30	MEC 200L	3 x 400 V - Δ	52	52	IE2 / IE3
	37	MEC 200L	3 x 400 V - Δ	64	63	IE2 / IE3
	45	MEC 225M	3 x 400 V - Δ	78.5	76	IE2 / IE3

MODEL	POWER (kW)	UNIT DIMENSIONS (mm)									FLANGE DIMENSIONS (mm)		STANDARD COUPLING				SPACER COUPLING				REF.	
		A	A2	H2	H	H3	L1	L3	B2	B3	D	DNA	DNM	IE2		IE3		IE2		IE3		
		L	WEIGHT kg	L	WEIGHT kg	L	WEIGHT kg	L	WEIGHT kg	L	WEIGHT kg	L	WEIGHT kg	L	WEIGHT kg	L	WEIGHT kg	L	WEIGHT kg			
KDN 50-250	15	100	75	225	80	260	1250	840	540	490	24	65	50	1080	260	1080	233	1180	265	1180	238	6
	18.5	100	75	225	80	260	1250	840	540	490	24	65	50	1135	289	1123	257	1235	294	1223	262	6
	22	100	75	225	80	260	1250	840	540	490	24	65	50	1155	319	1155	277	1255	324	1255	282	6
	30	100	75	225	100	300	1400	940	610	550	28	65	50	1235	407	1245	419	1335	412	1345	424	7
	37	100	75	225	100	300	1400	940	610	550	28	65	50	1235	333	1245	358	1335	338	1345	363	7
	45	100	75	225	100	325	1400	940	610	550	28	65	50	1280	374	1285	413	1380	379	1385	418	7

Dimension and electrical data based on sizing definition following the instructions on page 96.

KDN 65-125 - 2 POLES - STANDARDISED CENTRIFUGAL ELECTRIC PUMPS FOR AIR CONDITIONING, REFRIGERATION, IRRIGATION, DECANTING, PRESSURISATION SYSTEMS, AND INDUSTRIAL APPLICATIONS

Pumped liquid temperature range: from -10 °C to +140 °C - Maximum ambient temperature: +40°C

= 2900 1/min

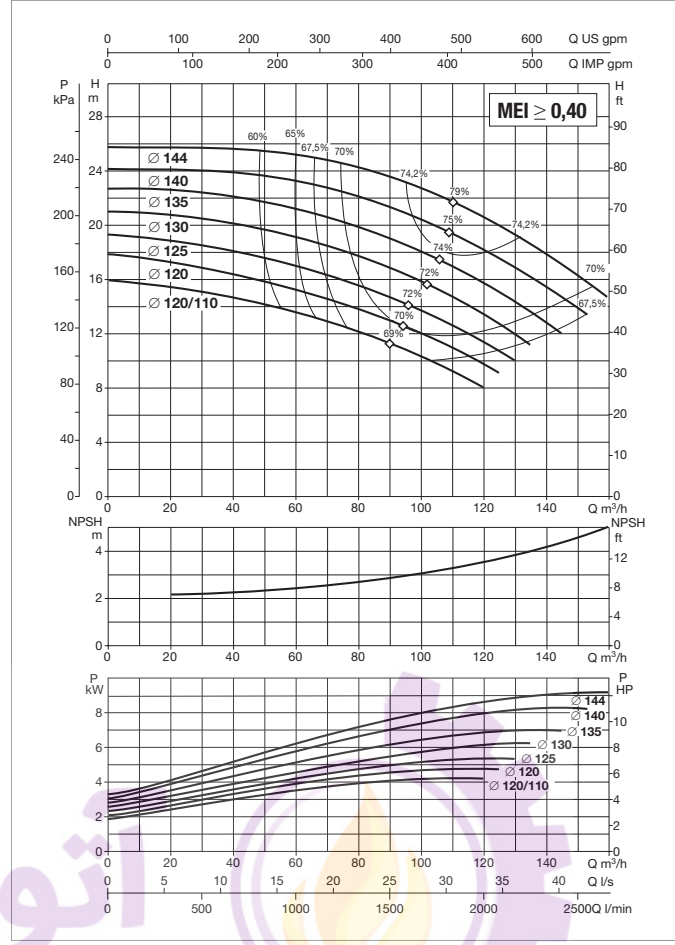
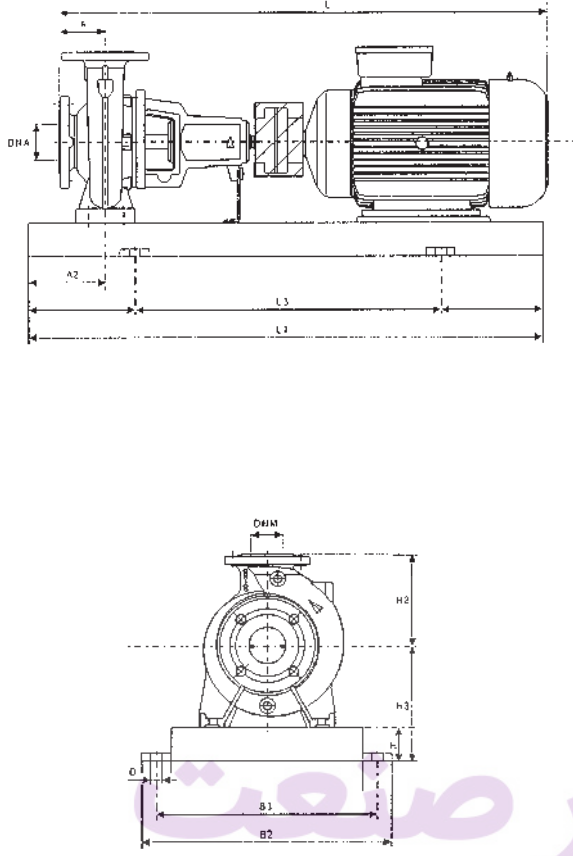

See hydraulic efficiency details on page 291.

The performance curves are based on kinematic viscosity values = 1 mm²/s and density equal to 1000 kg/m³. Curve tolerance according to ISO 9906.

آتور صنعت
ATOORSANAT

MODEL	ELECTRICAL DATA					
	POWER (kW) 2 POLES	MOTOR SIZE	POWER INPUT 50 Hz	In A		MOTOR TYPE
				IE2	IE3	
KDN 65-125	4	MEC 112M	3 x 400 V - Δ	8.05	-	IE2
	5.5	MEC 132S	3 x 400 V - Δ	10.4	-	IE2
	7.5	MEC 132S	3 x 400 V - Δ	14	13.4	IE2 / IE3
	11	MEC 160M	3 x 400 V - Δ	20.2	19.4	IE2 / IE3
	15	MEC 160M	3 x 400 V - Δ	27	26.5	IE2 / IE3

MODEL	POWER (kW)	UNIT DIMENSIONS (mm)										FLANGE DIMENSIONS (mm)		STANDARD COUPLING				SPACER COUPLING				REF.
		A	A2	H2	H	H3	L1	L3	B2	B3	D	DNA	DNM	IE2		IE3		IE2		IE3		
														L	WEIGHT kg	L	WEIGHT kg	L	WEIGHT kg	L	WEIGHT kg	
KDN 65-125	4	100	60	180	65	225	900	600	390	350	19	80	65	865	132	-	-	965	137	-	-	3
	5.5	100	60	180	80	240	1000	660	450	400	24	80	65	935	143	-	-	1035	148	-	-	4
	7.5	100	60	180	80	240	1000	660	450	400	24	80	65	935	146	945	120	1035	151	1045	125	4
	11	100	60	180	80	240	1120	740	490	440	24	80	65	1080	175	1080	152	1180	180	1180	157	5
	15	100	60	180	80	240	1120	740	490	440	24	80	65	1080	180	1080	153	1180	185	1180	158	5

Dimension and electrical data based on sizing definition following the instructions on page 96.

KDN 65-160 - 2 POLES - STANDARDISED CENTRIFUGAL ELECTRIC PUMPS FOR AIR CONDITIONING, REFRIGERATION, IRRIGATION, DECANTING, PRESSURISATION SYSTEMS, AND INDUSTRIAL APPLICATIONS

Pumped liquid temperature range: from -10 °C to +140 °C - Maximum ambient temperature: +40°C

= 2900 1/min

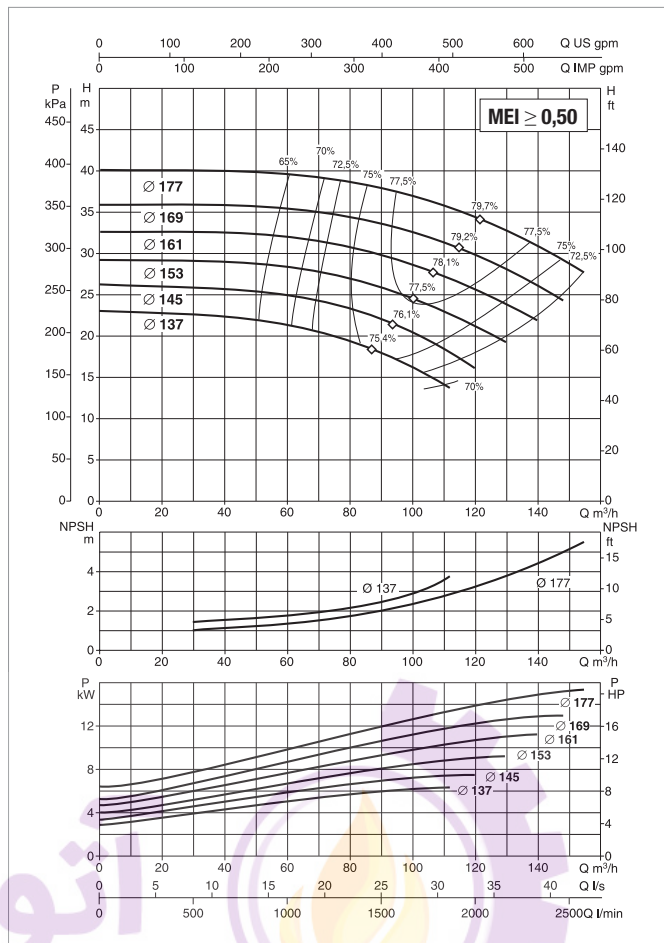
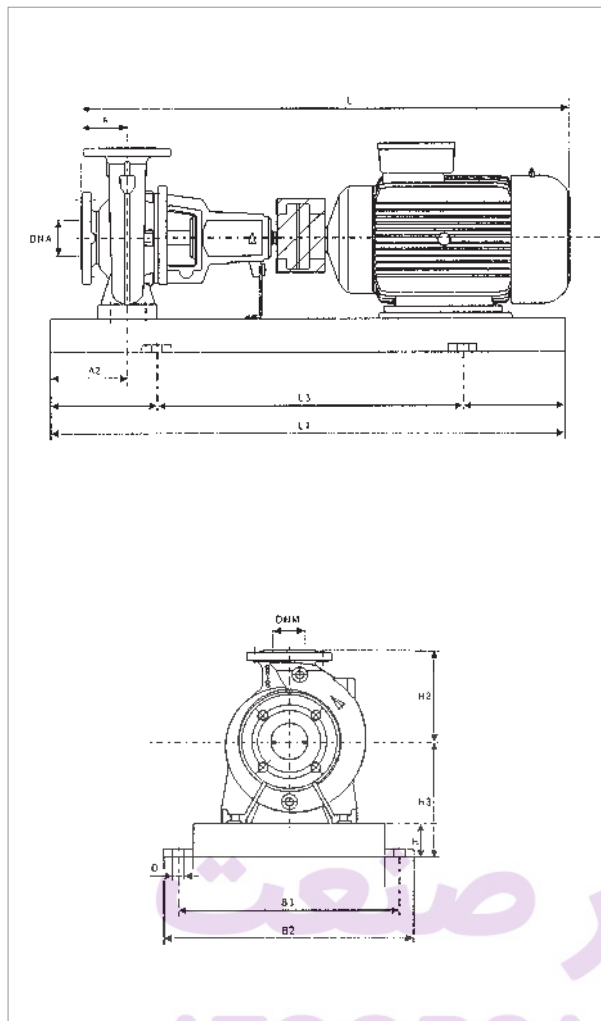

See hydraulic efficiency details on page 291.

The performance curves are based on kinematic viscosity values = 1 mm²/s and density equal to 1000 kg/m³. Curve tolerance according to ISO 9906.

MODEL	ELECTRICAL DATA					
	POWER (kW) 2 POLES	MOTOR SIZE	POWER INPUT 50 Hz	In A		MOTOR TYPE
				IE2	IE3	
KDN 65-160	5.5	MEC 132S	3 x 400 V - Δ	10.4	-	IE2
	7.5	MEC 132S	3 x 400 V - Δ	14	13.4	IE2 / IE3
	11	MEC 160M	3 x 400 V - Δ	20.2	19.4	IE2 / IE3
	15	MEC 160M	3 x 400 V - Δ	27	26.5	IE2 / IE3
	18.5	MEC 160L	3 x 400 V - Δ	33	32	IE2 / IE3
	22	MEC 180M	3 x 400 V - Δ	39.5	38	IE2 / IE3

MODEL	POWER (kW)	UNIT DIMENSIONS (mm)										FLANGE DIMENSIONS (mm)		STANDARD COUPLING				SPACER COUPLING				REF.
		A	A2	H2	H	H3	L1	L3	B2	B3	D	DNA	DNM	IE2		IE3		IE2		IE3		
		L	WEIGHT kg	L	WEIGHT kg	L	WEIGHT kg	L	WEIGHT kg	L	WEIGHT kg	L	WEIGHT kg	L	WEIGHT kg	L	WEIGHT kg	L	WEIGHT kg			
KDN 65-160	5.5	100	60	200	80	240	1000	660	450	400	24	80	65	935	149	-	-	1035	154	-	-	4
	7.5	100	60	200	80	240	1000	660	450	400	24	80	65	935	173	945	147	1035	178	1045	152	4
	11	100	60	200	80	240	1120	740	490	440	24	80	65	1080	183	1080	160	1180	188	1180	165	5
	15	100	60	200	80	240	1120	740	490	440	24	80	65	1080	220	1080	193	1180	225	1180	198	5
	18.5	100	60	200	80	240	1120	740	490	440	24	80	65	1135	220	1123	188	1235	225	1223	193	5
	22	100	60	200	80	260	1120	740	490	440	24	80	65	1155	220	1155	178	1255	225	1255	183	5

Dimension and electrical data based on sizing definition following the instructions on page 96.

KDN 65-200 - 2 POLES - STANDARDISED CENTRIFUGAL ELECTRIC PUMPS FOR AIR CONDITIONING, REFRIGERATION, IRRIGATION, DECANTING, PRESSURISATION SYSTEMS, AND INDUSTRIAL APPLICATIONS

Pumped liquid temperature range: from -10 °C to +140 °C - Maximum ambient temperature: +40°C

= 2900 1/min

CENTRIFUGAL PUMPS

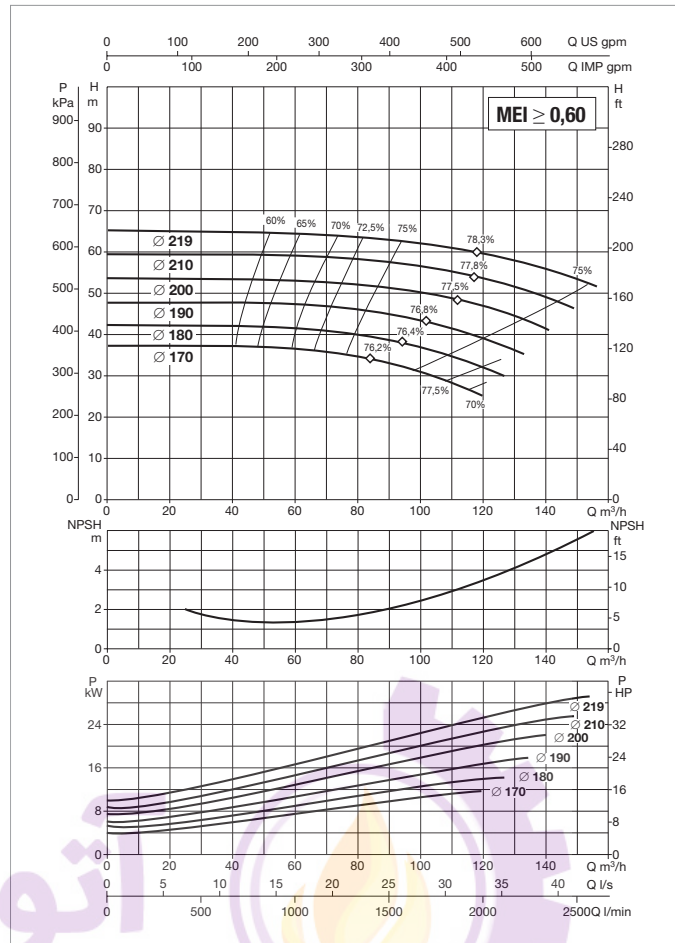
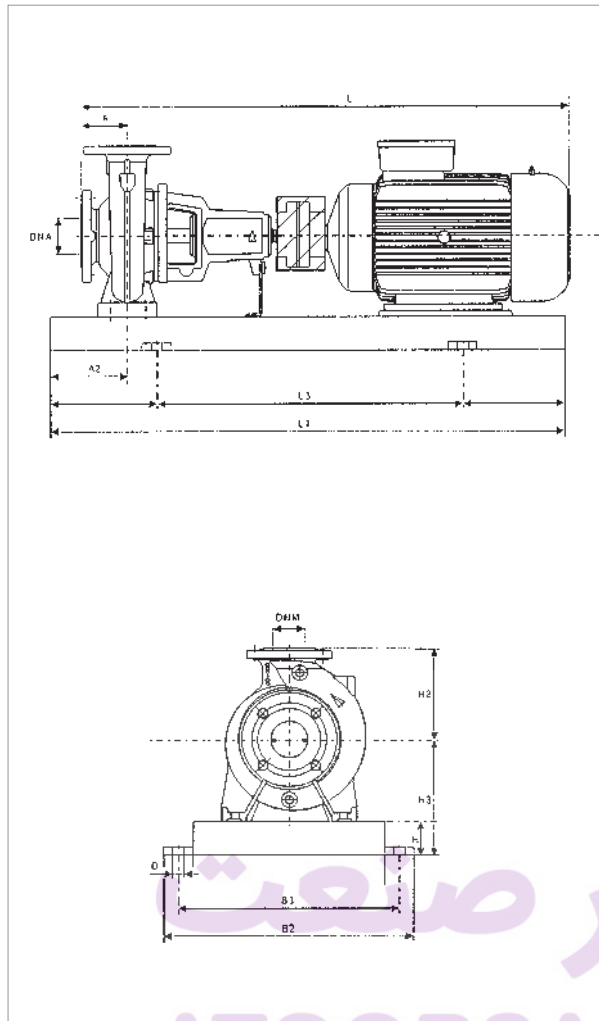

See hydraulic efficiency details on page 291.

The performance curves are based on kinematic viscosity values = 1 mm²/s and density equal to 1000 kg/m³. Curve tolerance according to ISO 9906.

MODEL	ELECTRICAL DATA					
	POWER (kW) 2 POLES	MOTOR SIZE	POWER INPUT 50 Hz	In A		MOTOR TYPE
				IE2	IE3	
KDN 65-200	11	MEC 160M	3 x 400 V - Δ	20.2	19.4	IE2 / IE3
	15	MEC 160M	3 x 400 V - Δ	27	26.5	IE2 / IE3
	18.5	MEC 160L	3 x 400 V - Δ	33	32	IE2 / IE3
	22	MEC 180M	3 x 400 V - Δ	39.5	38	IE2 / IE3
	30	MEC 200L	3 x 400 V - Δ	52	52	IE2 / IE3
	37	MEC 200L	3 x 400 V - Δ	64	63	IE2 / IE3

MODEL	POWER (kW)	UNIT DIMENSIONS (mm)										FLANGE DIMENSIONS (mm)		STANDARD COUPLING				SPACER COUPLING				REF.
		A	A2	H2	H	H3	L1	L3	B2	B3	D	DNA	DNM	IE2		IE3		IE2		IE3		
		L	WEIGHT kg	L	WEIGHT kg	L	WEIGHT kg	L	WEIGHT kg	L	WEIGHT kg	L	WEIGHT kg	L	WEIGHT kg	L	WEIGHT kg	L	WEIGHT kg			
KDN 65-200	11	100	75	225	80	260	1250	840	540	490	24	80	65	1080	267	1080	244	1220	272	1220	249	6
	15	100	75	225	80	260	1250	840	540	490	24	80	65	1080	279	1080	252	1220	284	1220	257	6
	18.5	100	75	225	80	260	1250	840	540	490	24	80	65	1135	289	1123	257	1235	294	1223	262	6
	22	100	75	225	80	260	1250	840	540	490	24	80	65	1155	332	1155	290	1295	337	1295	295	6
	30	100	75	225	100	300	1400	940	610	550	28	80	65	1235	406	1245	418	1375	411	1385	423	7
	37	100	75	225	100	300	1400	940	610	550	28	80	65	1235	406	1245	431	1375	411	1385	436	7

Dimension and electrical data based on sizing definition following the instructions on page 96.

KDN 65-250 - 2 POLES - STANDARDISED CENTRIFUGAL ELECTRIC PUMPS FOR AIR CONDITIONING, REFRIGERATION, IRRIGATION, DECANTING, PRESSURISATION SYSTEMS, AND INDUSTRIAL APPLICATIONS

Pumped liquid temperature range: from -10 °C to +140 °C - Maximum ambient temperature: +40°C

= 2900 1/min

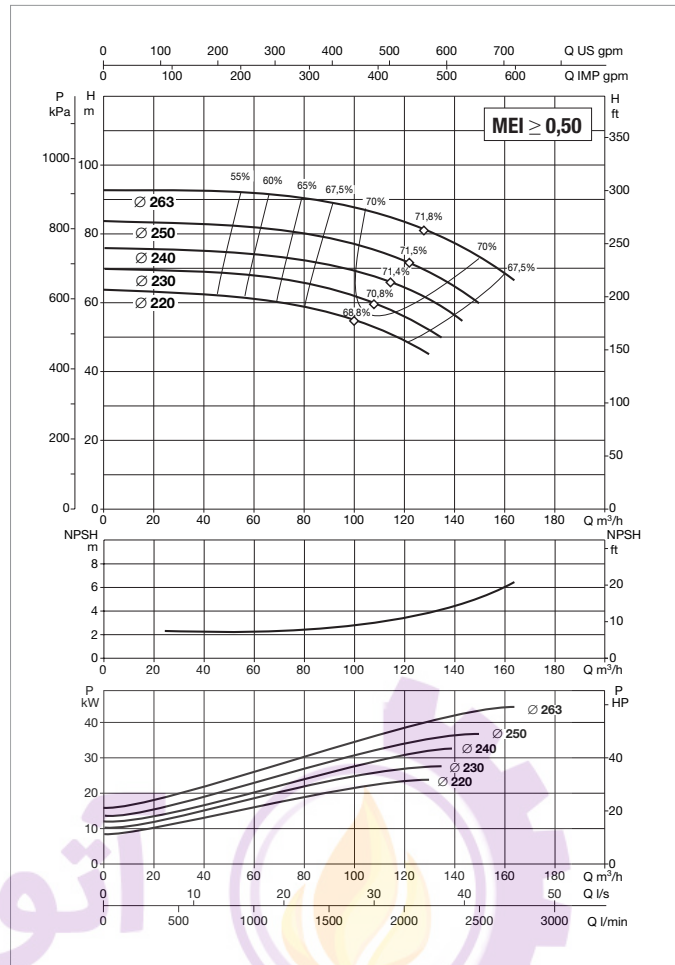
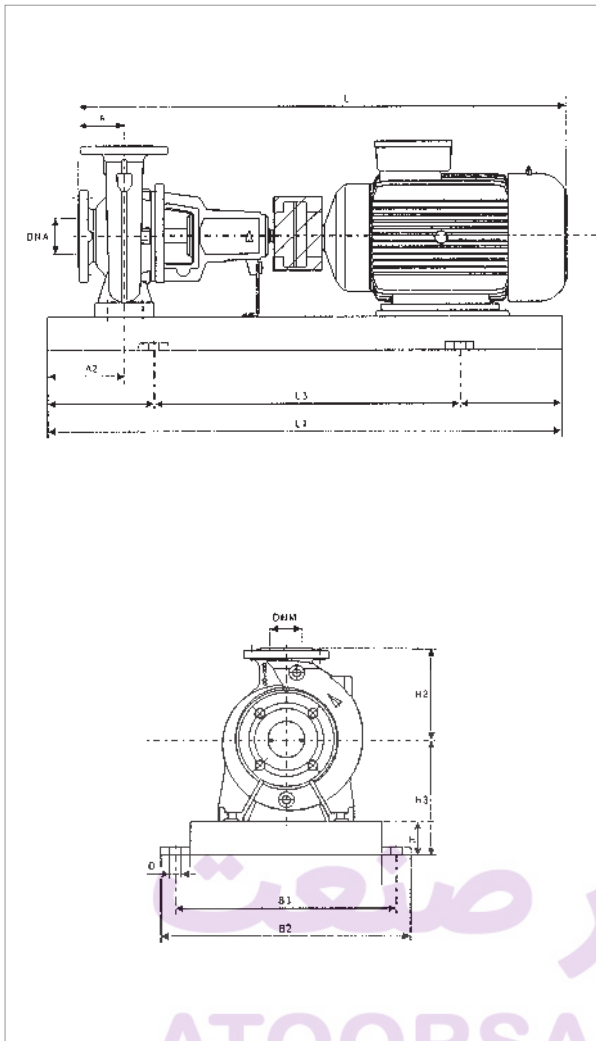

See hydraulic efficiency details on page 291.

The performance curves are based on kinematic viscosity values = 1 mm²/s and density equal to 1000 kg/m³. Curve tolerance according to ISO 9906.

MODEL	ELECTRICAL DATA					
	POWER (kW)	MOTOR SIZE	POWER INPUT 50 Hz	In A		MOTOR TYPE
				IE2	IE3	
KDN 65-250	22	MEC 180M	3 x 400 V - Δ	39.5	38	IE2 / IE3
	30	MEC 200L	3 x 400 V - Δ	52	52	IE2 / IE3
	37	MEC 200L	3 x 400 V - Δ	64	63	IE2 / IE3
	45	MEC 225M	3 x 400 V - Δ	78.5	76	IE2 / IE3
	55	MEC 225M	3 x 400 V - Δ	94	95	IE2 / IE3

MODEL	POWER (kW)	UNIT DIMENSIONS (mm)										FLANGE DIMENSIONS (mm)		STANDARD COUPLING				SPACER COUPLING				REF.
		A	A2	H2	H	H3	L1	L3	B2	B3	D	DNA	DNM	IE2		IE3		IE2		IE3		
														L	WEIGHT kg	L	WEIGHT kg	L	WEIGHT kg	L	WEIGHT kg	
KDN 65-250	22	100	90	250	80	280	1250	840	540	490	24	80	65	1265	319	1265	277	1405	327	1405	285	6
	30	100	90	250	80	300	1400	940	610	550	28	80	65	1345	460	1355	472	1485	468	1495	480	7
	37	100	90	250	80	300	1400	940	610	550	28	80	65	1345	477	1355	502	1485	485	1495	510	7
	45	100	90	250	80	325	1400	940	610	550	28	80	65	1390	550	1395	589	1530	558	1535	597	7
	55	100	90	250	80	350	1600	1060	660	600	24	80	65	1490	672	1460	717	1630	680	1600	725	8

Dimension and electrical data based on sizing definition following the instructions on page 96.

KDN 65-315 - 2 POLES - STANDARDISED CENTRIFUGAL ELECTRIC PUMPS FOR AIR CONDITIONING, REFRIGERATION, IRRIGATION, DECANTING, PRESSURISATION SYSTEMS, AND INDUSTRIAL APPLICATIONS

Pumped liquid temperature range: from -10 °C to +140 °C - Maximum ambient temperature: +40°C

= 2900 1/min

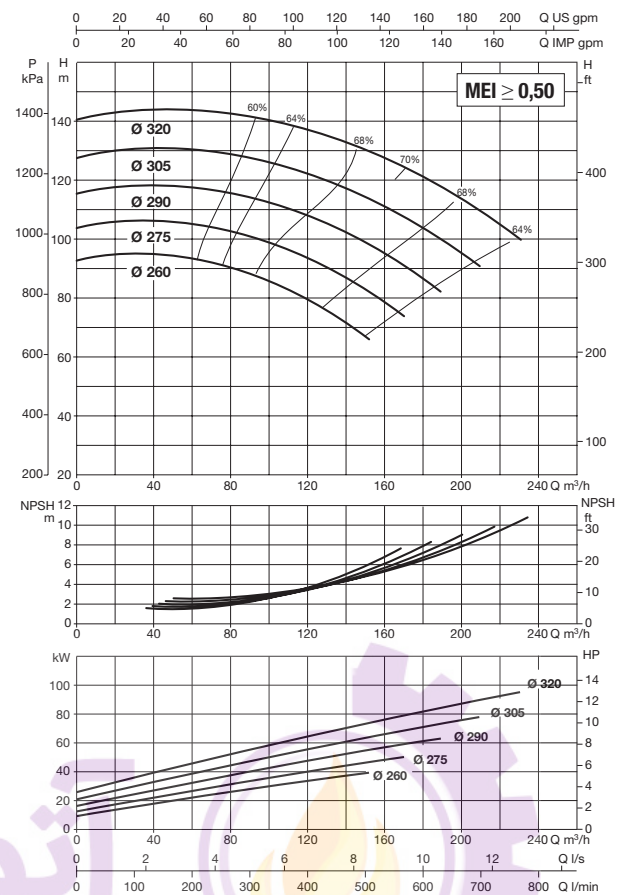
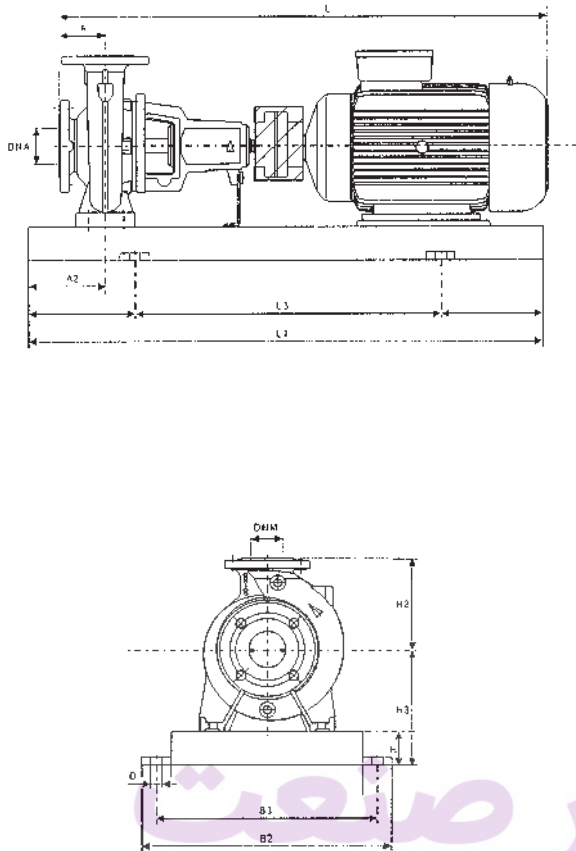

See hydraulic efficiency details on page 291.

The performance curves are based on kinematic viscosity values = 1 mm²/s and density equal to 1000 kg/m³. Curve tolerance according to ISO 9906.

MODEL	ELECTRICAL DATA					
	POWER (kW) 2 POLES	MOTOR SIZE	POWER INPUT 50 Hz	In A		MOTOR TYPE
				IE2	IE3	
KDN 65-315	45	MEC 225M	3 x 400 V - Δ	78.5	76	IE2 / IE3
	55	MEC 250M	3 x 400 V - Δ	94	95	IE2 / IE3
	75	MEC 280S	3 x 400 V - Δ	130	124	IE2 / IE3
	90	MEC 280M	3 x 400 V - Δ	154	148	IE2 / IE3
	110	MEC 315S	3 x 400 V - Δ	188	184	IE2 / IE3

MODEL	POWER (kW)	UNIT DIMENSIONS (mm)										FLANGE DIMENSIONS (mm)		STANDARD COUPLING				SPACER COUPLING				REF.
		A	A2	H2	H	H3	L1	L3	B2	B3	D	DNA	DNM	IE2		IE3		IE2		IE3		
														L	WEIGHT kg	L	WEIGHT kg	L	WEIGHT kg	L	WEIGHT kg	
KDN 65-315	45	125	90	280	100	325	1600	1060	660	600	28	80	65	1415	695	1420	734	1555	703	1560	742	8
	55	125	90	280	100	325	1600	1060	660	600	28	80	65	1515	695	1515	740	1655	703	1655	748	8
	75	125	90	280	100	325	1800	1200	730	670	28	80	65	1570	849	1568	849	1710	857	1708	857	9
	90	125	90	280	100	325	1800	1200	730	670	28	80	65	1620	669	1620	651	1760	677	1760	659	9
	110	125	90	280	100	325	2000	1340	910	830	28	80	65	1840	1119	1805	1219	1980	1127	1945	1227	9

Dimension and electrical data based on sizing definition following the instructions on page 96.

KDN 80-160 - 2 POLES - STANDARDISED CENTRIFUGAL ELECTRIC PUMPS FOR AIR CONDITIONING, REFRIGERATION, IRRIGATION, DECANTING, PRESSURISATION SYSTEMS, AND INDUSTRIAL APPLICATIONS

Pumped liquid temperature range: from -10 °C to +140 °C - Maximum ambient temperature: +40°C

= 2900 1/min

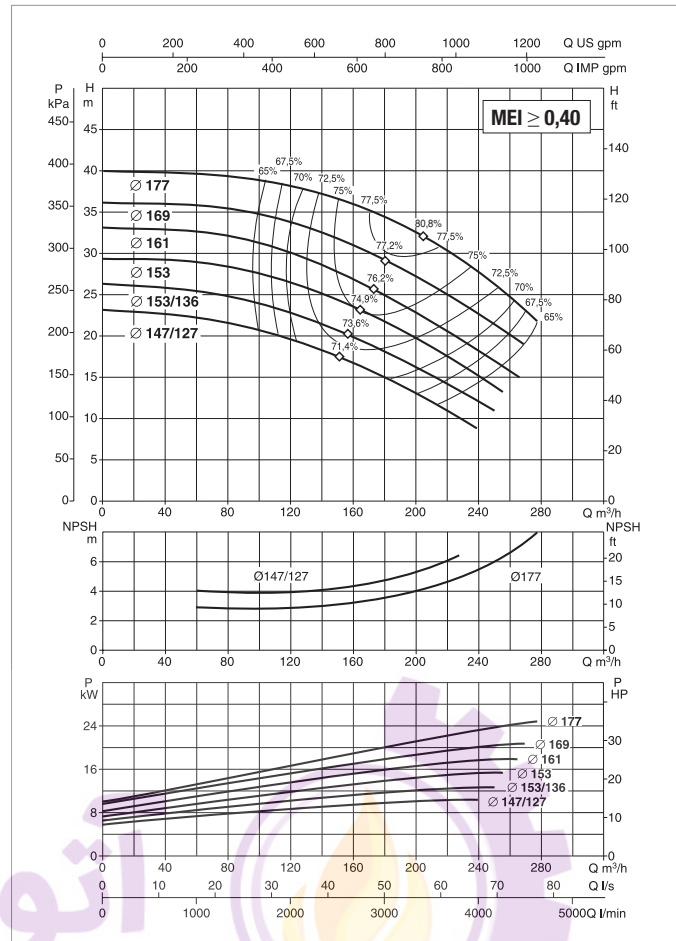
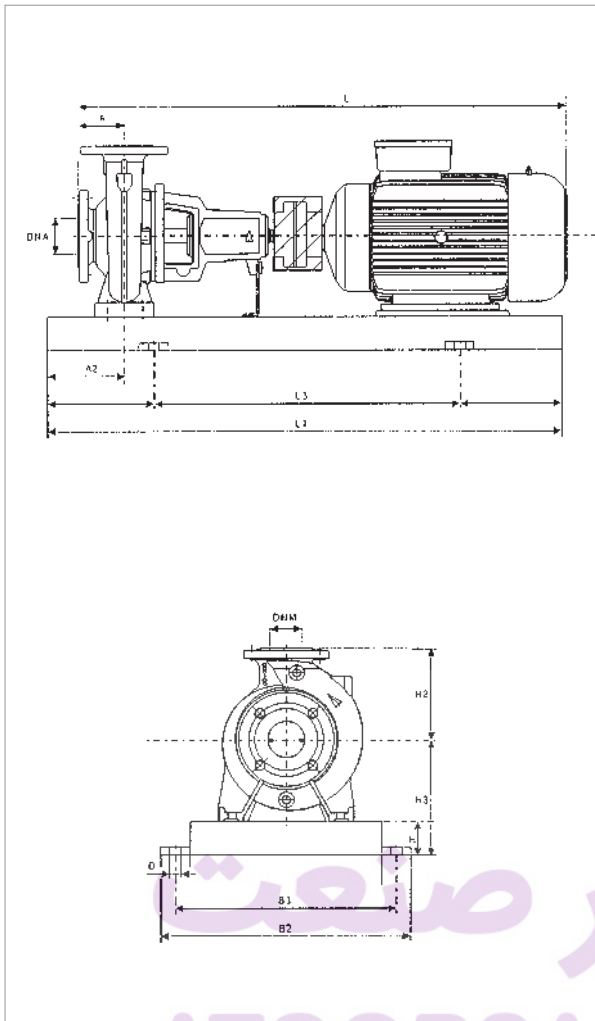

See hydraulic efficiency details on page 291.

The performance curves are based on kinematic viscosity values = 1 mm²/s and density equal to 1000 kg/m³. Curve tolerance according to ISO 9906.

MODEL	ELECTRICAL DATA					
	POWER (kW)	MOTOR SIZE	POWER INPUT 50 Hz	In A		MOTOR TYPE
	2 POLES			IE2	IE3	
KDN 80-160	7.5	MEC 132S	3 x 400 V - Δ	14	13.4	IE2 / IE3
	11	MEC 160M	3 x 400 V - Δ	20.2	19.4	IE2 / IE3
	15	MEC 160M	3 x 400 V - Δ	27	26.5	IE2 / IE3
	18.5	MEC 160L	3 x 400 V - Δ	33	32	IE2 / IE3
	22	MEC 180M	3 x 400 V - Δ	39.5	38	IE2 / IE3
	30	MEC 200L	3 x 400 V - Δ	52	52	IE2 / IE3
	37	MEC 200L	3 x 400 V - Δ	64	63	IE2 / IE3

MODEL	POWER (kW)	UNIT DIMENSIONS (mm)										FLANGE DIMENSIONS (mm)		STANDARD COUPLING				SPACER COUPLING				REF.
		A	A2	H2	H	H3	L1	L3	B2	B3	D	DNA	DNM	IE2		IE3		IE2		IE3		
		L	WEIGHT kg	L	WEIGHT kg	L	WEIGHT kg	L	WEIGHT kg	L	WEIGHT kg											
KDN 80-160	7.5	125	75	225	80	260	1120	740	490	440	24	100	80	960	189	970	163	1100	197	1110	171	5
	11	125	75	225	80	260	1250	840	540	490	24	100	80	1105	298	1105	275	1245	306	1245	283	6
	15	125	75	225	80	260	1250	840	540	490	24	100	80	1105	298	1105	271	1245	306	1245	279	6
	18.5	125	75	225	80	260	1250	840	540	490	24	100	80	1160	298	1148	266	1300	306	1288	274	6
	22	125	75	225	80	260	1250	840	540	490	24	100	80	1180	253	1180	211	1320	261	1320	219	6
	30	125	75	225	80	260	1400	940	610	550	28	100	80	1260	304	1270	316	1400	312	1410	324	7
37	125	75	225	80	260	1400	940	610	550	28	100	80	1260	383	1270	408	1400	391	1410	416	7	

Dimension and electrical data based on sizing definition following the instructions on page 96.

KDN 80-200 - 2 POLES - STANDARDISED CENTRIFUGAL ELECTRIC PUMPS FOR AIR CONDITIONING, REFRIGERATION, IRRIGATION, DECANTING, PRESSURISATION SYSTEMS, AND INDUSTRIAL APPLICATIONS

Pumped liquid temperature range: from -10 °C to +140 °C - Maximum ambient temperature: +40°C

= 2900 1/min

CENTRIFUGAL PUMPS

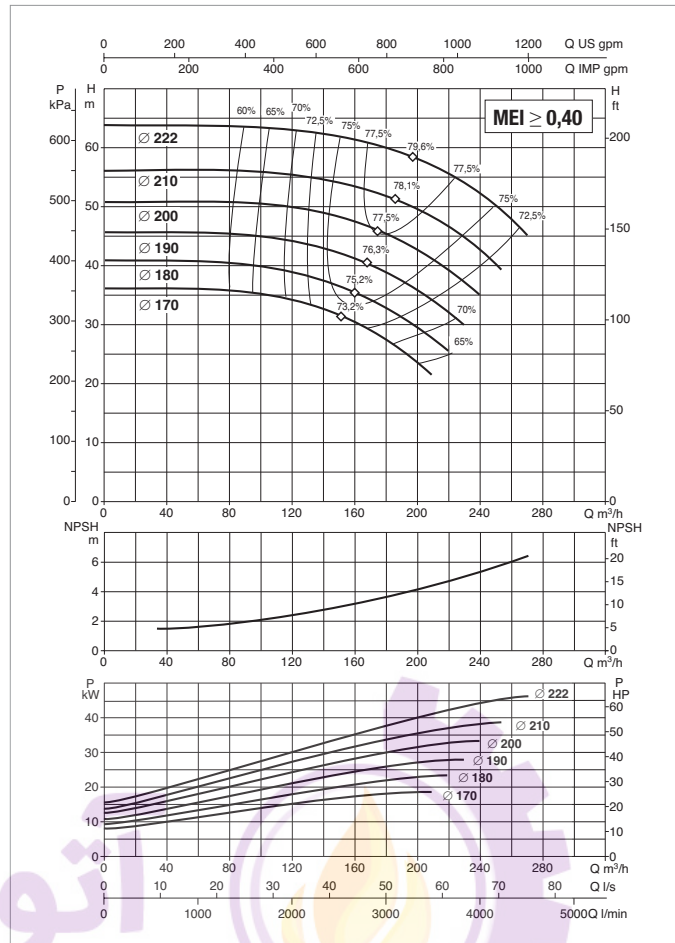
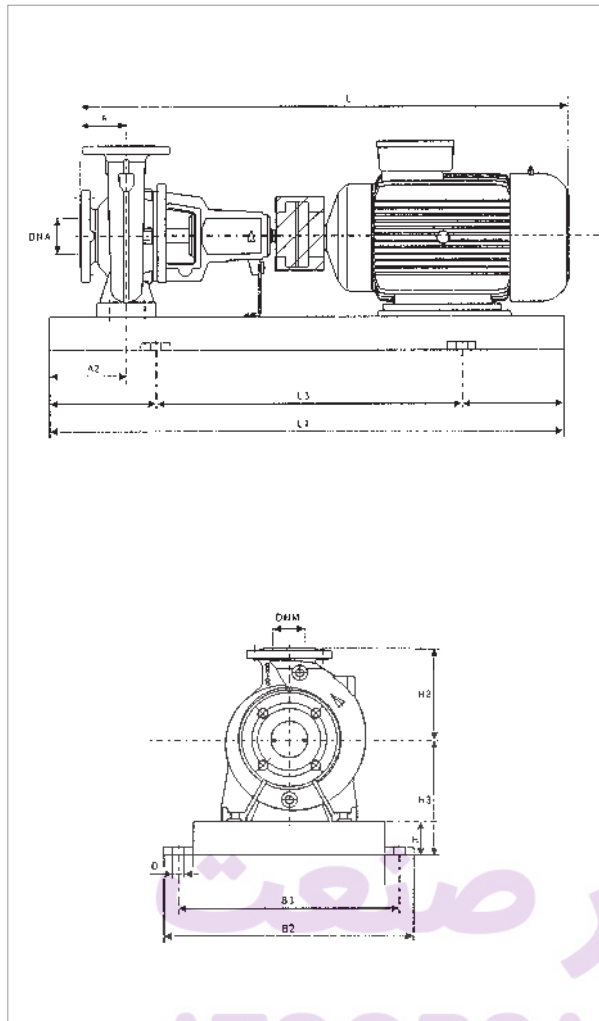

See hydraulic efficiency details on page 291.

The performance curves are based on kinematic viscosity values = 1 mm²/s and density equal to 1000 kg/m³. Curve tolerance according to ISO 9906.

MODEL	ELECTRICAL DATA					
	POWER (kW)	MOTOR SIZE	POWER INPUT 50 Hz	In A		MOTOR TYPE
	2 POLES			IE2	IE3	
KDN 80-200	18.5	MEC 160L	3 x 400 V - Δ	33	32	IE2 / IE3
	22	MEC 180M	3 x 400 V - Δ	39.5	38	IE2 / IE3
	30	MEC 200L	3 x 400 V - Δ	52	52	IE2 / IE3
	37	MEC 200L	3 x 400 V - Δ	64	63	IE2 / IE3
	45	MEC 225M	3 x 400 V - Δ	78.5	76	IE2 / IE3
	55	MEC 250M	3 x 400 V - Δ	94	95	IE2 / IE3
	75	MEC 280S	3 x 400 V - Δ	130	124	IE2 / IE3

MODEL	POWER (kW)	UNIT DIMENSIONS (mm)										FLANGE DIMENSIONS (mm)			STANDARD COUPLING				SPACER COUPLING				REF.
		A	A2	H2	H	H3	L1	L3	B2	B3	D	DNA	DNM	IE2		IE3		IE2		IE3			
		L	WEIGHT kg	L	WEIGHT kg	L	WEIGHT kg	L	WEIGHT kg	L	WEIGHT kg	L	WEIGHT kg	L	WEIGHT kg	L	WEIGHT kg	L	WEIGHT kg				
KDN 80-200	18.5	125	75	250	80	260	1250	840	540	490	24	100	80	1270	239	1258	207	1410	247	1398	215	6	
	22	125	75	250	80	260	1250	840	540	490	24	100	80	1290	275	1290	233	1430	283	1430	241	6	
	30	125	75	250	100	300	1400	940	610	550	28	100	80	1370	432	1380	444	1510	440	1520	452	7	
	37	125	75	250	100	300	1400	940	610	550	28	100	80	1370	455	1380	480	1510	463	1520	488	7	
	45	125	75	250	100	325	1400	940	610	550	28	100	80	1415	548	1420	587	1555	556	1560	595	7	
	55	125	75	250	100	350	1600	1060	660	600	28	100	80	1515	494	1515	539	1655	502	1655	547	8	
75	125	75	250	100	380	1800	1200	730	670	28	100	80	1570	609	1568	609	1710	617	1708	617	9		

Dimension and electrical data based on sizing definition following the instructions on page 96.

KDN 80-250 - 2 POLES - STANDARDISED CENTRIFUGAL ELECTRIC PUMPS FOR AIR CONDITIONING, REFRIGERATION, IRRIGATION, DECANTING, PRESSURISATION SYSTEMS, AND INDUSTRIAL APPLICATIONS

Pumped liquid temperature range: from -10 °C to +140 °C - Maximum ambient temperature: +40°C

= 2900 1/min

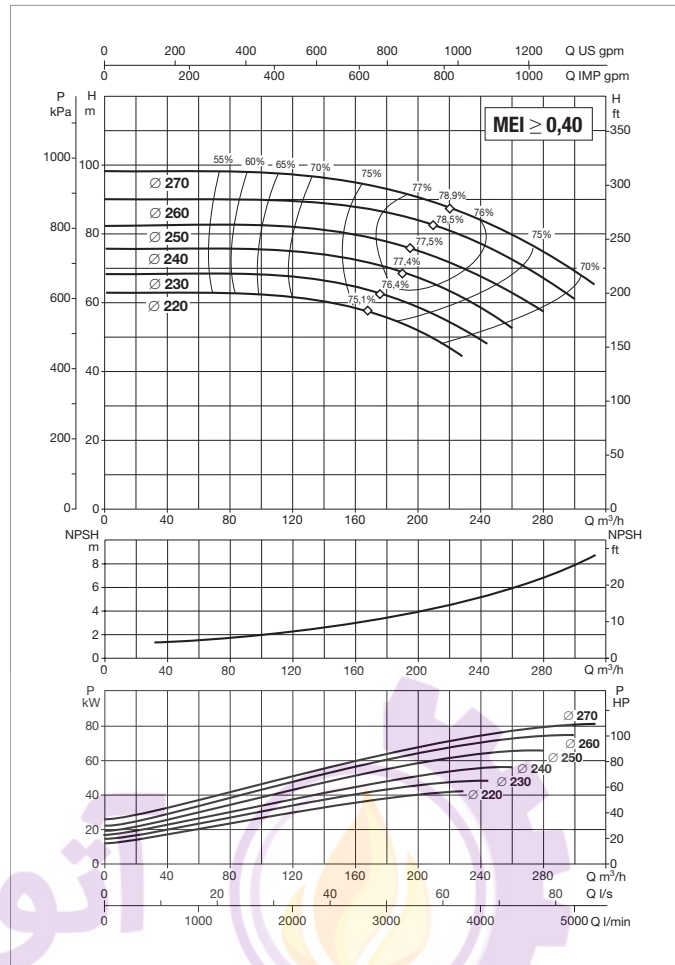
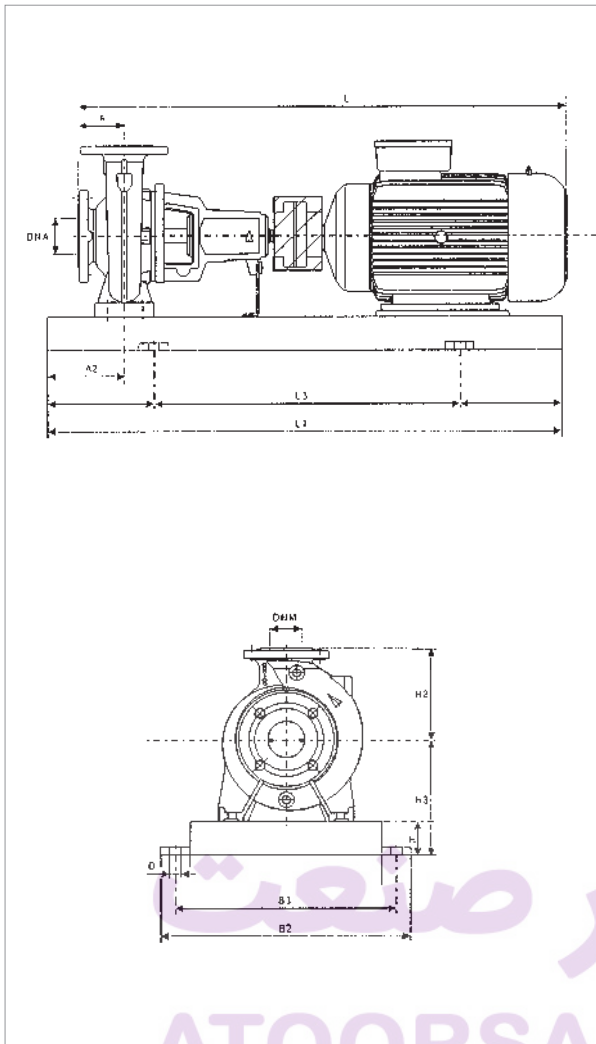

See hydraulic efficiency details on page 291.

The performance curves are based on kinematic viscosity values = 1 mm²/s and density equal to 1000 kg/m³. Curve tolerance according to ISO 9906.

MODEL	ELECTRICAL DATA					
	POWER (kW) 2 POLES	MOTOR SIZE	POWER INPUT 50 Hz	In A		MOTOR TYPE
				IE2	IE3	
KDN 80-250	37	MEC 200L	3 x 400 V - Δ	64	63	IE2 / IE3
	45	MEC 225M	3 x 400 V - Δ	78.5	76	IE2 / IE3
	55	MEC 250M	3 x 400 V - Δ	94	95	IE2 / IE3
	75	MEC 280S	3 x 400 V - Δ	130	124	IE2 / IE3
	90	MEC 280M	3 x 400 V - Δ	154	148	IE2 / IE3

MODEL	POWER (kW)	UNIT DIMENSIONS (mm)										FLANGE DIMENSIONS (mm)		STANDARD COUPLING				SPACER COUPLING				REF.
		A	A2	H2	H	H3	L1	L3	B2	B3	D	DNA	DNM	IE2		IE3		IE2		IE3		
														L	WEIGHT kg	L	WEIGHT kg	L	WEIGHT kg	L	WEIGHT kg	
KDN 80-250	37	125	90	280	100	300	1400	940	610	550	28	100	80	1370	471	1380	496	1510	479	1520	504	7
	45	125	90	280	100	300	1400	940	610	550	28	100	80	1415	545	1420	584	1555	553	1560	592	7
	55	125	90	280	100	300	1600	1060	660	600	28	100	80	1515	650	1515	695	1655	658	1655	703	8
	75	125	90	280	100	300	1800	1200	730	670	28	100	80	1570	641	1568	641	1710	649	1708	649	9
	90	125	90	280	100	300	1800	1200	730	670	28	100	80	1620	909	1620	891	1760	917	1760	899	9

Dimension and electrical data based on sizing definition following the instructions on page 96.

KDN 80-315 - 2 POLES - STANDARDISED CENTRIFUGAL ELECTRIC PUMPS FOR AIR CONDITIONING, REFRIGERATION, IRRIGATION, DECANTING, PRESSURISATION SYSTEMS, AND INDUSTRIAL APPLICATIONS

Pumped liquid temperature range: from -10 °C to +140 °C - Maximum ambient temperature: +40°C

= 2900 1/min

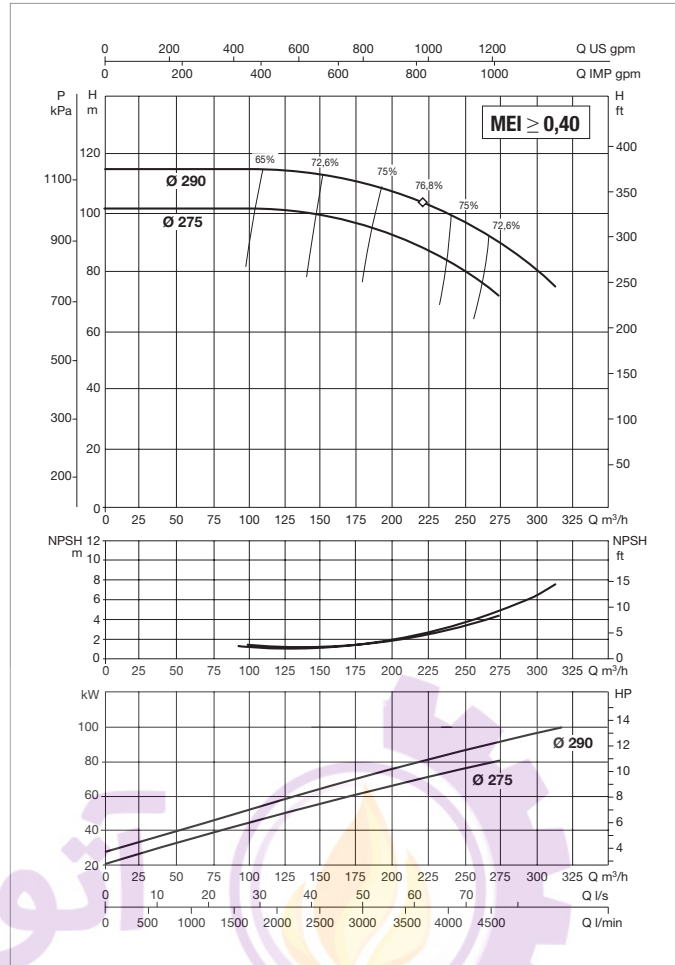
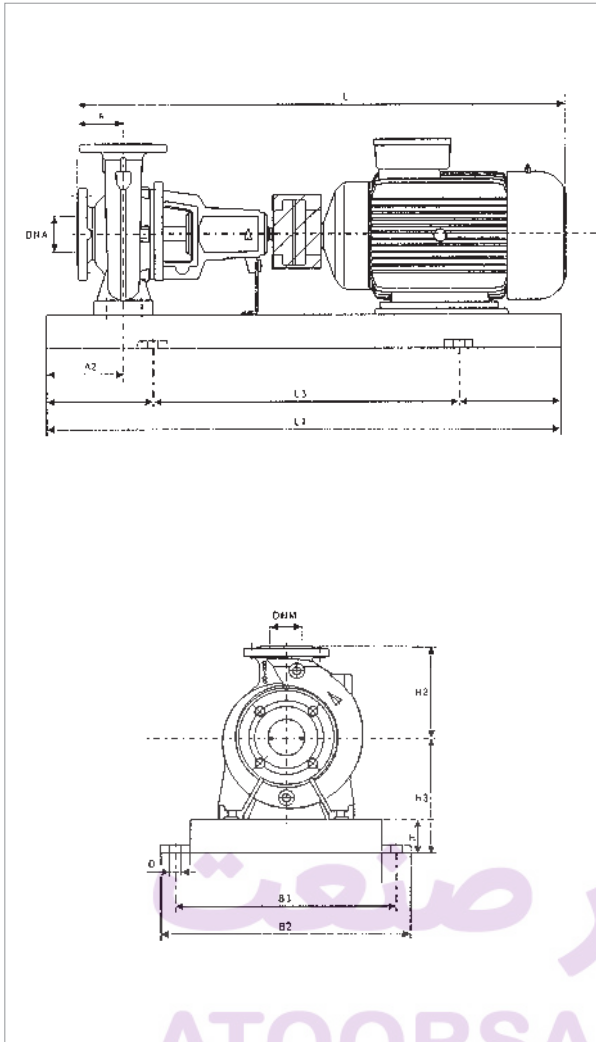

See hydraulic efficiency details on page 291.

The performance curves are based on kinematic viscosity values = 1 mm²/s and density equal to 1000 kg/m³. Curve tolerance according to ISO 9906.

MODEL	ELECTRICAL DATA					
	POWER (kW) 2 POLES	MOTOR SIZE	POWER INPUT 50 Hz	In A		MOTOR TYPE
				IE2	IE3	
KDN 80-315	55	MEC 250M	3 x 400 V ~ Δ	94	95	IE2 / IE3
	75	MEC 280S	3 x 400 V ~ Δ	130	124	IE2 / IE3
	90	MEC 280M	3 x 400 V ~ Δ	154	148	IE2 / IE3
	110	MEC 315S	3 x 400 V ~ Δ	188	184	IE2 / IE3

MODEL	POWER (kW)	UNIT DIMENSIONS (mm)										FLANGE DIMENSIONS (mm)		STANDARD COUPLING				SPACER COUPLING				REF.
		A	A2	H2	H	H3	L1	L3	B2	B3	D	DNA	DNM	IE2		IE3		IE2		IE3		
		L	WEIGHT kg	L	WEIGHT kg	L	WEIGHT kg	L	WEIGHT kg	L	WEIGHT kg	L	WEIGHT kg	L	WEIGHT kg	L	WEIGHT kg	L	WEIGHT kg			
KDN 80-315	55	125	90	315	100	350	1600	1060	660	600	28	100	80	1515	707	1515	538	1655	715	1655	546	8
	75	125	90	315	100	350	1800	1200	730	670	28	100	80	1570	861	1568	628	1710	869	1708	636	9
	90	125	90	315	100	350	1800	1200	730	670	28	100	80	1620	681	1620	663	1760	689	1760	671	9
	110	125	90	315	120	370	2000	1340	910	830	28	100	80	1840	1131	1805	1231	1980	1139	1945	1239	9

Dimension and electrical data based on sizing definition following the instructions on page 96.

KDN 100-200 - 2 POLES - STANDARDISED CENTRIFUGAL ELECTRIC PUMPS FOR AIR CONDITIONING, REFRIGERATION, IRRIGATION, DECANTING, PRESSURISATION SYSTEMS, AND INDUSTRIAL APPLICATIONS

Pumped liquid temperature range: from -10 °C to +140 °C - Maximum ambient temperature: +40°C

= 2900 1/min

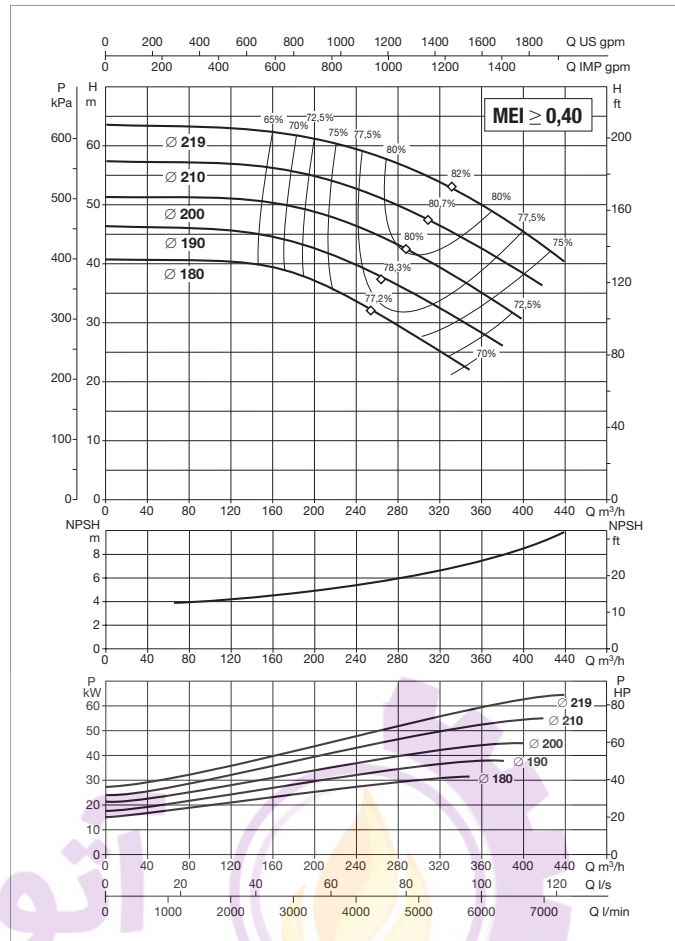
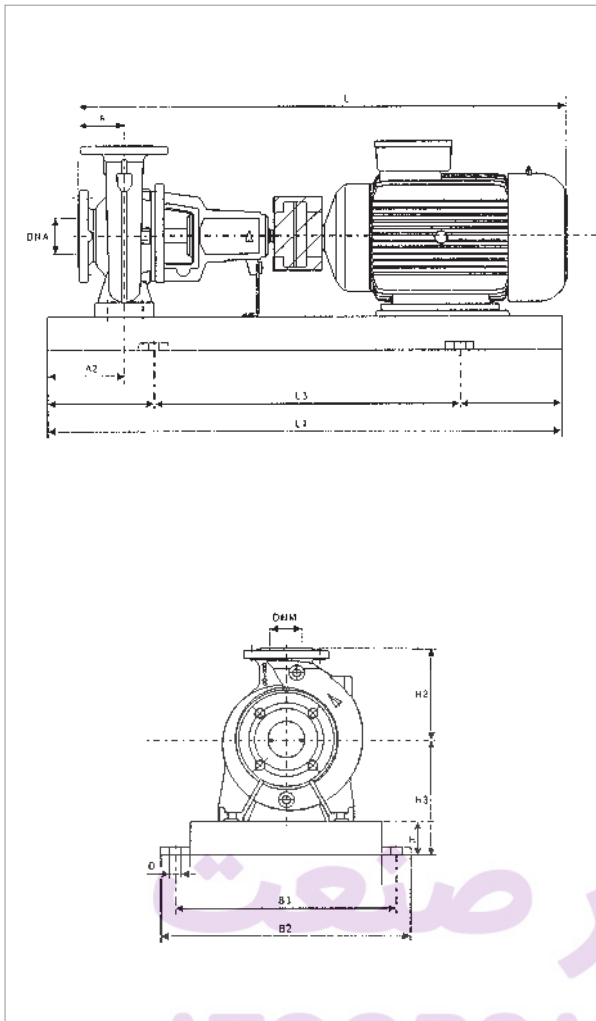

See hydraulic efficiency details on page 291.

The performance curves are based on kinematic viscosity values = 1 mm²/s and density equal to 1000 kg/m³. Curve tolerance according to ISO 9906.

MODEL	ELECTRICAL DATA					
	POWER (kW)	MOTOR SIZE	POWER INPUT 50 Hz	In A		MOTOR TYPE
	2 POLES			IE2	IE3	
KDN 100-200	30	MEC 200L	3 x 400 V - Δ	52	52	IE2 / IE3
	37	MEC 200L	3 x 400 V - Δ	64	63	IE2 / IE3
	45	MEC 225M	3 x 400 V - Δ	78.5	76	IE2 / IE3
	55	MEC 250M	3 x 400 V - Δ	94	95	IE2 / IE3
	75	MEC 280S	3 x 400 V - Δ	130	124	IE2 / IE3
	90	MEC 280M	3 x 400 V - Δ	154	148	IE2 / IE3

MODEL	POWER (kW)	UNIT DIMENSIONS (mm)										FLANGE DIMENSIONS (mm)		STANDARD COUPLING				SPACER COUPLING				REF.
		A	A2	H2	H	H3	L1	L3	B2	B3	D	DNA	DNM	IE2		IE3		IE2		IE3		
		L	WEIGHT kg	L	WEIGHT kg	L	WEIGHT kg	L	WEIGHT kg	L	WEIGHT kg	L	WEIGHT kg	L	WEIGHT kg	L	WEIGHT kg	L	WEIGHT kg			
KDN 100-200	30	125	90	280	100	300	1400	940	610	550	28	125	100	1370	454	1380	466	1510	462	1520	474	7
	37	125	90	280	100	300	1400	940	610	550	28	125	100	1370	402	1380	427	1510	410	1520	435	7
	45	125	90	280	100	325	1400	940	610	550	28	125	100	1415	549	1420	588	1555	557	1560	596	7
	55	125	90	280	100	350	1600	1060	660	600	28	125	100	1515	623	1515	668	1655	631	1655	676	8
	75	125	90	280	100	380	1800	1200	730	670	28	125	100	1570	621	1568	621	1710	629	1708	629	9
	90	125	90	280	100	380	1800	1200	730	670	28	125	100	1620	621	1620	603	1760	629	1760	611	9

Dimension and electrical data based on sizing definition following the instructions on page 96.

KDN 100-250 - 2 POLES - STANDARDISED CENTRIFUGAL ELECTRIC PUMPS FOR AIR CONDITIONING, REFRIGERATION, IRRIGATION, DECANTING, PRESSURISATION SYSTEMS, AND INDUSTRIAL APPLICATIONS

Pumped liquid temperature range: from -10 °C to +140 °C - Maximum ambient temperature: +40°C

= 2900 1/min

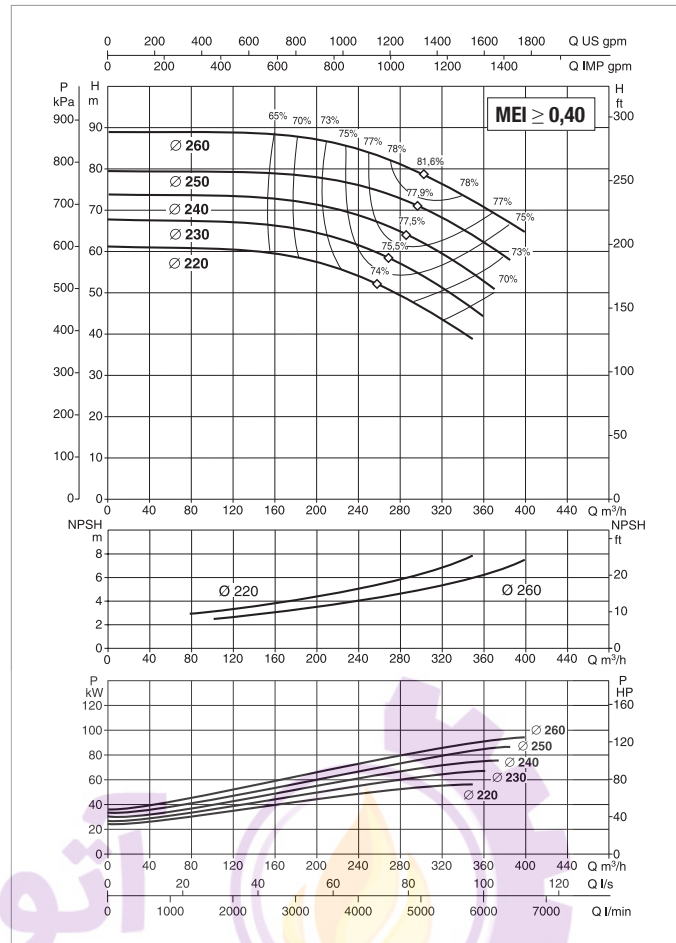
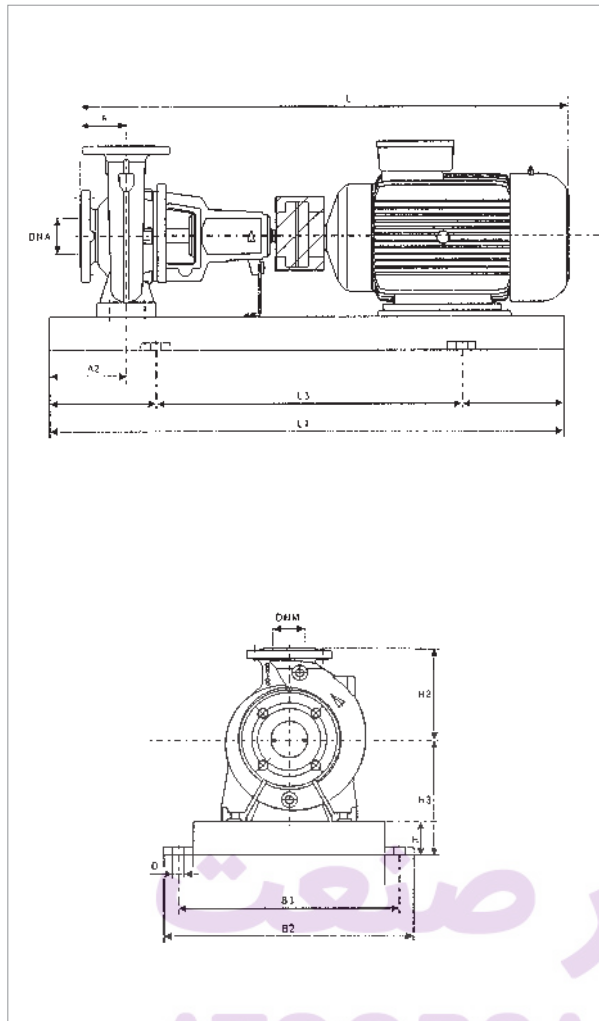

See hydraulic efficiency details on page 291.

The performance curves are based on kinematic viscosity values = 1 mm²/s and density equal to 1000 kg/m³. Curve tolerance according to ISO 9906.

MODEL	ELECTRICAL DATA					
	POWER (kW) 2 POLES	MOTOR SIZE	POWER INPUT 50 Hz	In A		MOTOR TYPE
				IE2	IE3	
KDN 100-250	45	MEC 225M	3 x 400 V - Δ	78.5	76	IE2 / IE3
	55	MEC 250M	3 x 400 V - Δ	94	95	IE2 / IE3
	75	MEC 280S	3 x 400 V - Δ	130	124	IE2 / IE3
	90	MEC 280M	3 x 400 V - Δ	154	148	IE2 / IE3
	110	MEC 315S	3 x 400 V - Δ	188	184	IE2 / IE3

MODEL	POWER (kW)	UNIT DIMENSIONS (mm)										FLANGE DIMENSIONS (mm)		STANDARD COUPLING				SPACER COUPLING				REF.
		A	A2	H2	H	H3	L1	L3	B2	B3	D	DNA	DNM	IE2		IE3		IE2		IE3		
		L	WEIGHT kg	L	WEIGHT kg	L	WEIGHT kg	L	WEIGHT kg	L	WEIGHT kg	L	WEIGHT kg	L	WEIGHT kg	L	WEIGHT kg	L	WEIGHT kg			
KDN 100-250	45	125	90	280	100	325	1600	1060	660	600	28	125	100	1430	696	1435	735	1570	704	1575	743	8
	55	125	90	280	100	325	1600	1060	600	600	28	125	100	1530	696	1530	741	1670	704	1670	749	8
	75	125	90	280	100	380	1800	1200	730	670	28	125	100	1585	850	1583	850	1725	858	1723	858	9
	90	125	90	280	100	380	1800	1200	730	670	28	125	100	1635	670	1635	652	1775	678	1775	660	9
	110	125	90	280	100	435	2000	1340	910	830	28	125	100	1855	1120	1820	1220	1995	1128	1960	1228	9

Dimension and electrical data based on sizing definition following the instructions on page 96.

KDN - 2 POLES

STANDARDISED CENTRIFUGAL ELECTRIC PUMPS

IE2 STANDARD MOTOR ELECTRIC DATA

=2900 1/min

MOTOR TYPE	P2 NOMINAL kW	SPEED rpm	YIELD %	POWER FACTOR COS φ	POWER INPUT 50 Hz	In A		Start-up current Ia/In	Start-up torque Ma/Mn	Maximum torque M/k/ Mn	POLES
						230	400				
MEC 71	0.25	2790	69.81	0.778	3 x 230/400	1.15	0.67	5.06	2.90	3.01	2
MEC 71	0.37	2820	72.79	0.783	3 x 230/400	1.61	0.93	5.40	2.69	2.99	2
MEC 80	0.55	2810	76.97	0.800	3 x 230/400	2.23	1.29	6.41	3.43	3.13	2
MEC 80	0.75	2880	81.52	0.823	3 x 230/400	2.81	1.62	7.93	3.47	3.33	2
MEC 80	1.10	2870	81.82	0.826	3 x 230/400	4.07	2.36	7.92	3.42	3.25	2
MEC 90S	1.50	2880	82.95	0.794	3 x 230/400	5.80	3.35	8.85	4.18	3.80	2
MEC 90L	2.20	2870	83.41	0.811	3 x 230/400	8.23	4.75	8.31	3.87	1.87	2

MOTOR TYPE	P2 NOMINAL kW	SPEED rpm	YIELD %	POWER FACTOR COS φ	POWER INPUT 50 Hz	In A		Start-up current Ia/In	Start-up torque Ma/Mn	Maximum torque M/k/ Mn	POLES
						400	690				
MEC 100L	3.00	2880	86.25	0.861	3 x 400 Δ	5.85	3.40	8.93	3.17	3.70	2
MEC 112M	4.00	2910	87.10	0.856	3 x 400 Δ	8.05	4.65	9.14	2.99	3.53	2
MEC 132S	5.50	2910	88.40	0.873	3 x 400 Δ	10.40	6.00	7.77	2.53	3.26	2
MEC 132S	7.50	2900	88.40	0.882	3 x 400 Δ	14.00	8.08	7.62	2.34	3.11	2
MEC 160M	11.00	2930	89.82	0.890	3 x 400 Δ	20.20	11.66	6.24	2.16	2.79	2
MEC 160M	15.00	2940	90.46	0.890	3 x 400 Δ	27.00	15.59	7.03	2.57	3.02	2
MEC 160L	18.50	2940	91.49	0.893	3 x 400 Δ	33.00	19.05	7.27	2.69	3.21	2
MEC 180M	22.00	2960	92.05	0.875	3 x 400 Δ	39.50	23.00	8.33	2.80	3.43	2
MEC 200L	30.00	2950	92.50	0.899	3 x 400 Δ	52.00	30.02	7.79	2.37	3.06	2
MEC 200L	37.00	2960	92.90	0.897	3 x 400 Δ	64.00	36.95	7.62	2.50	3.22	2
MEC 225M	45.00	2960	92.94	0.901	3 x 400 Δ	78.50	45.32	6.73	2.40	2.85	2
MEC 250M	55.00	2970	93.97	0.900	3 x 400 Δ	94.00	54.50	8.33	2.42	3.04	2
MEC 280S	75.00	2980	94.12	0.895	3 x 400 Δ	130.00	74.50	7.73	2.36	3.21	2
MEC 280M	90.00	2980	94.51	0.918	3 x 400 Δ	154.00	89.00	7.97	2.80	3.44	2
MEC 315S	110.00	2980	94.53	0.893	3 x 400 Δ	188.00	110.00	8.06	2.53	3.53	2
MEC 315M	132.00	2970	94.80	0.923	3 x 400 Δ	220.00	130.00	6.18	2.14	2.77	2
MEC 315L	160.00	2970	94.80	0.926	3 x 400 Δ	265.00	155.00	5.96	2.12	2.65	2
MEC 315L	200.00	2970	95.20	0.925	3 x 400 Δ	330.00	190.00	5.78	2.10	2.55	2
MEC355M	250.00	2980	96.04	0.897	3 x 400 Δ	418.50	242.60	7.84	2.37	3.77	2
MEC355L	315.00	2980	96.43	0.903	3 x 400 Δ	521.50	302.30	7.96	2.36	3.81	2

KDN - 2 POLES

STANDARDISED CENTRIFUGAL ELECTRIC PUMPS

IE3 STANDARD MOTOR ELECTRIC DATA

=2900 1/min

MOTOR TYPE	P2 NOMINAL kW	SPEED rpm	YIELD %	POWER FACTOR COS φ	POWER INPUT 50 Hz	In A		Start-up current Ia/In	Start-up torque Ma/Mn	Maximum torque M/k/Mn	POLES
						400	690				
MEC 132S	7.50	2920	90.10	0.900	3 x 400 Δ	13.40	7.75	8.50	2.20	3.20	2
MEC 160M	11.00	2940	91.20	0.900	3 x 400 Δ	19.40	11.21	7.60	2.40	3.30	2
MEC 160M	15.00	2920	91.30	0.900	3 x 400 Δ	26.50	15.32	7.70	2.60	3.30	2
MEC 160L	18.50	2920	92.40	0.910	3 x 400 Δ	32.00	18.50	8.20	2.80	3.40	2
MEC 180M	22.00	2950	92.70	0.910	3 x 400 Δ	38.00	21.97	8.70	2.60	3.90	2
MEC 200L	30.00	2960	93.30	0.890	3 x 400 Δ	52.00	30.06	9.00	3.00	3.90	2
MEC 200L	37.00	2960	93.70	0.910	3 x 400 Δ	63.00	36.42	9.00	3.10	3.90	2
MEC 225M	45.00	2960	94.00	0.910	3 x 400 Δ	76.00	43.93	8.30	2.50	3.60	2
MEC 250M	55.00	2970	94.30	0.890	3 x 400 Δ	95.00	54.91	7.20	2.30	3.60	2
MEC 280S	75.00	2970	94.70	0.920	3 x 400 Δ	124.00	71.68	8.00	2.40	3.30	2
MEC 280M	90.00	2970	95.00	0.920	3 x 400 Δ	148.00	85.55	8.10	2.50	3.30	2
MEC 315S	110.00	2980	95.20	0.910	3 x 400 Δ	184.00	106.36	6.70	1.80	3.10	2
MEC 315M	132.00	2980	95.40	0.920	3 x 400 Δ	220.00	127.17	6.50	1.80	2.90	2
MEC 315L	160.00	2980	95.60	0.920	3 x 400 Δ	265.00	153.18	6.60	1.90	2.80	2
MEC 315L	200.00	2980	95.80	0.920	3 x 400 Δ	330.00	190.75	6.10	1.80	2.60	2
MEC 355M	250.00	2980	95.80	0.920	3 x 400 Δ	410.00	236.99	6.90	2.00	2.90	2
MEC 355L	315.00	2980	95.80	0.920	3 x 400 Δ	520.00	300.58	5.70	1.70	2.40	2