

TR

TRANSFER PUMPS



These **portable** drum-transfer immersion pumps are designed to pump corrosive liquids and have no internal mechanical seals. Their special shape ensures that any spillages are collected in the drum.

Available with fully-interchangeable **electric or pneumatic motor**, these pumps have an open impeller that allows continuous pumping of clean corrosive liquids having **apparent viscosity of up to 600 cps with 500-watt electric and pneumatic motor (at 20°C) and 900 cps with 800-watt electric motor (at 20°C)**. TR-EL series pumps driven by an electric motor are also fitted with a safety cut-out switch that prevents accidental restart after a power outage.

آتور صنعت
ATOORSANAT



DEBEM



Available in PP, PVDF e Aisi 316

Inexpensive;

Portable;

Handles corrosive liquids;

Viscosity up to 900 cps;

Available with either electric or pneumatic motor;

Adjustable flow rate
(pneumatic version);

No internal seals;

Easily dismantled;

Dip tube length = 900 mm o 1200 mm;

Flow rate up to 90 l/min.

DESCRIPTION OF THE PUMPS

These drum transfer pumps consist of a dip tube the end of which houses the open impeller that is secured to the driveshaft connected to the pump by means of a convenient ring nut, whilst transmission is provided by a shaft coupling.

TR-PN



TR-EL

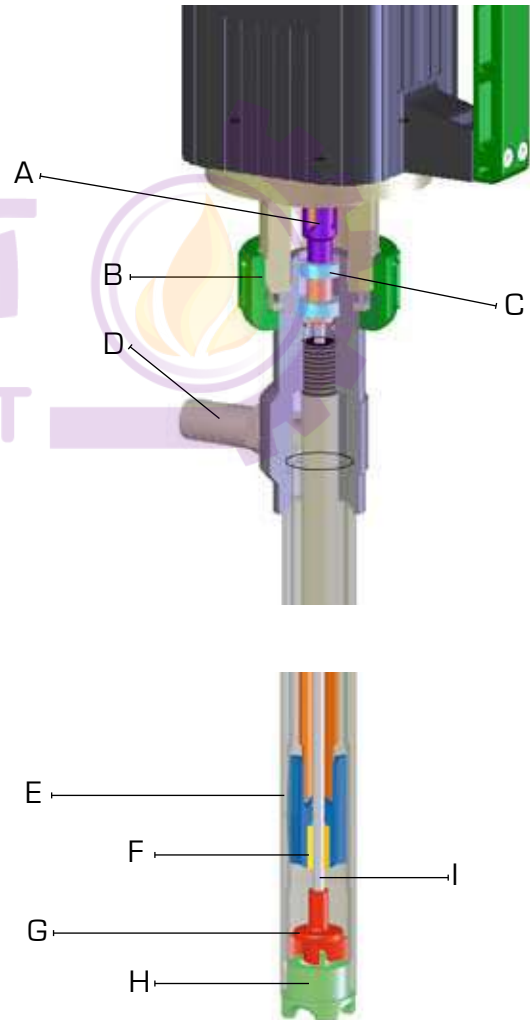

HOW IT WORKS

The impeller is integral with the shaft and coupled to the electric or pneumatic motor that makes it rotate, thus creating the centrifugal effect.

A = drive coupling
B = motor ring nut
C = bearing
D = delivery duct
E = dip tube

F = PTFE bushing
G = impeller
H = suction port
I = shaft

INSTALLATION

TR drum transfer pumps should only be used with the shaft positioned vertically and the pump immersed in the drum, whilst liquid must be present. Running dry or with air bubbles can cause damage to the internal bushing.

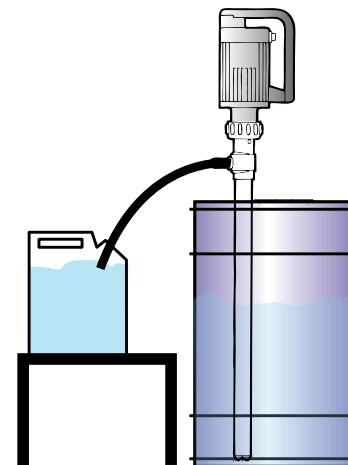

CHEMICAL COMPATIBILITY

The type of liquid, temperature and working environment are factors to be considered when deciding on the best choice of construction materials for the pump and its correct chemical compatibility. The table below gives some examples of the most commonly-used substances:

SUBSTANCE	Polypropylene	PVDF (Halair®)	Acciaio INOX Aisi 316	PTFE (Teflon®)	PPSV	FPM (Vitoni®)
Acetaldehyde	A1	D	A	A	A	D
Acetamide	A1	C	A	A	A	B
Vinyl acetate	B1	A2	B	A2	-	A1
Acetylene	A1	A	A	A	A	A
Vinegar	A	B	A	A	A	A
Acetone	A	D	A	A	A	D
Fatty acids	A	A	A	A	-	A

- A = very good
- B = good
- C = poor, not recommended
- D = severe etching, not recommended
- = information not available
- 1 = satisfactory up to 22°C (72°F)
- 2 = satisfactory up to 48°C (120°F)

For further information, please do not hesitate to contact DEBEM's technical service department.

TR PUMPS COMPOSITION CODES

ex. **TRP1200EL**

TR in PP + Suction hose length 1200 + Electric motor

TR	P	1200	EL
Pump model	Material Pump	Suction hose length	Motor
TR - TRANSFER PUMPS	P - Polypropylene F - PVDF A - Aisi 316	0900 (900 mm) 1200 (1200 mm)	EL* - Electric motor PN - Pneumatic motor

* Standard electric motor is single-phase 50/60Hz



TR - EL

construction materials: PP - PVDF - Aisi 316

PUMP	TR P - EL	TR F - EL	TR A - EL
Suction hose	ø 42 mm	ø 40 mm	ø 42,5 mm
Hose clamp	ø 25 mm	ø 25 mm	ø 25 mm
Max. temp.	60°C	95°C	95°C
Motor power	500/800 Watt		
Motor voltage	230 V 50/60HZ		
Motor protection	IP 54	IP 54	IP 54
Motor class	F	F	F
Flow rate	500 W 80 l/min - 800 W 90 l/min		

PUMP	TR P - EL	TR F - EL	TR A - EL
Total Weight Kg	5.1 - 5.4	5.4 - 5.6	8.0 - 9.0
Suct. hose mat.	PP	PVDF	Aisi 316
Shaft material	HASTELLOY	HASTELLOY	HASTELLOY
Bushing material	PTFE	PTFE	PTFE
Rotor material	ECTFE	ECTFE	ECTFE
Intake port. mat.	PP	ECTFE	ECTFE
Internal parts	PP + PTFE	PVDF + PTFE	PTFE + PPSV
Viscosity	500 W 600 cps - 800 W 900 cps		

TECHNICAL DATA

TRP - EL



body PP

TRF - EL



body PVDF

TRA - EL



body Aisi 316

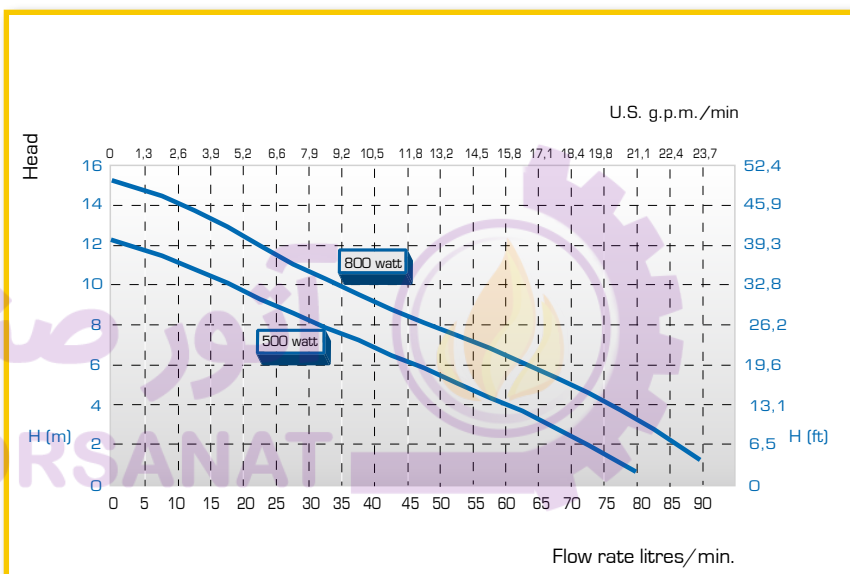

PERFORMANCE

The curves and performance values refer to pumps spare delivery outlet and water at 20°C.

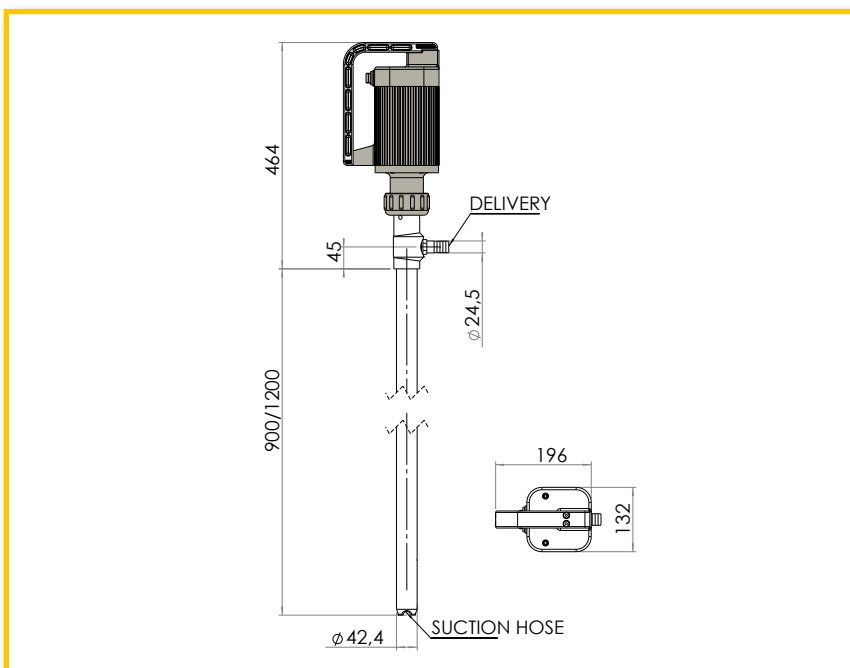

DIMENSIONS

All the values shown are approximate and not binding

Motor power 0,33 HP a 7bar - flow rate 80 l/min



TR - PN

construction materials: PP - PVDF - Aisi 316

TECHNICAL DATA

PUMP	TR P - PN	TR F - PN	TR A - PN
Suction hose	ø 42 mm	ø 40 mm	ø 42,5 mm
Hose clamp	ø 25 mm	ø 25 mm	ø 25 mm
Max. temp.	60°C	95°C	95°C
Motor power	0,33HP a 7bar	0,33HP a 7bar	0,33HP a 7bar
Total Weight Kg	2.5 - 2.8	2.8 - 3.0	5.4 - 5.5
Suct. hose mat.	PP	PVDF	Aisi 316
Flow rate	80 l/min		

PUMP	TR P - PN	TR F - PN	TR A - PN
Shaft material	HASTELLOY	HASTELLOY	Aisi 316
Bushing material	PTFE	PTFE	PTFE
Rotor material	ECTFE	ECTFE	ECTFE
Intake port. mat.	PP	ECTFE	ECTFE
Internal parts	PP + PTFE	PVDF + PTFE	PTE + PPSV
Viscosity	600 cps		

PERFORMANCE

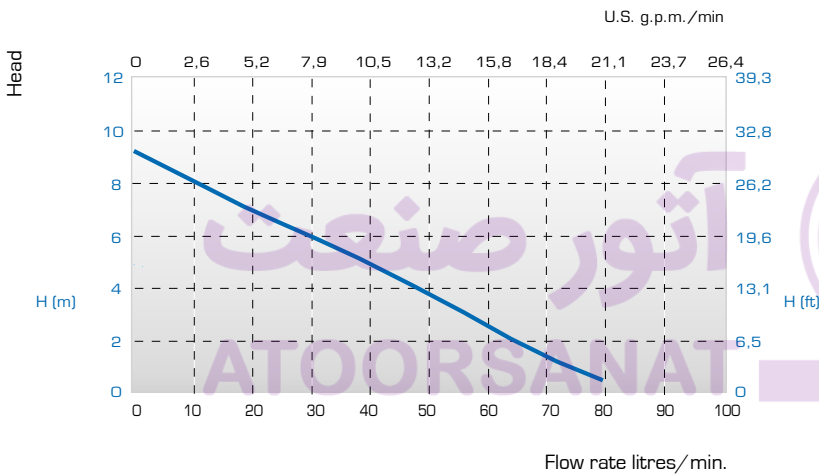

The curves and performance values refer to pumps spare delivery outlet and water at 20°C.

DIMENSIONS

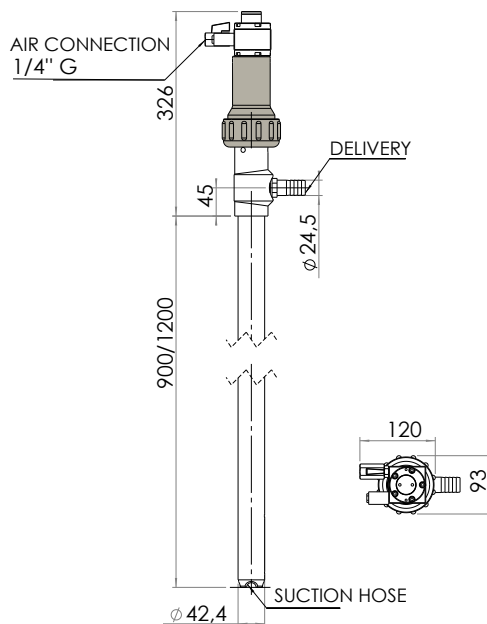

All the values shown are approximate and not binding

TRP - PN



body PP

TRF - PN



body in PVDF

TRA - PN



body Aisi 316

