

EBARA

CENTRIFUGAL PUMPS

2CDX

CONTENTS

50Hz

Rev. M

	Page
- SPECIFICATIONS	200
SELECTION CHART	201
TYPE KEY AND CURVE SPECIFICATIONS	202
PERFORMANCE CURVE 2CDX 70	203
PERFORMANCE CURVE 2CDX 120	204
PERFORMANCE CURVE 2CDX 200	205
- CONSTRUCTIONS	300
SECTIONAL VIEW	300
THERMAL INSULATION	301
MECHANICAL SEAL	302
- DIMENSIONS AND WEIGHT	400
PUMP	400
PACKING	401
- TECHNICAL DATA	500
MOTOR DATA	500
NOISE DATA	500

آتور صنعت
ATOORSANAT

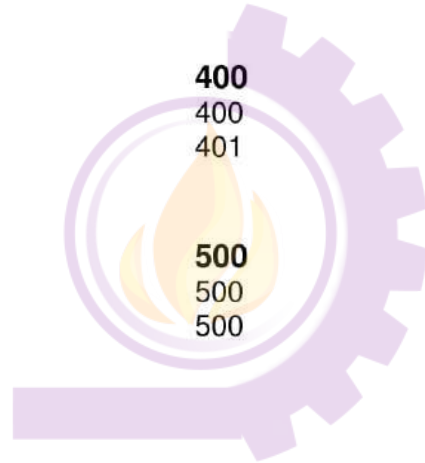

CENTRIFUGAL PUMPS

2CDX

SPECIFICATION

50Hz

Rev. M

PUMP		
Liquid Handled	Type of liquid	Clean water
	Temperature [°C]	min. -5 max. +60 max. +60 (L version-E) max. +110 (H-HS-HW-HSW)
Maximum working pressure [MPa]		0.8
Construction	Impeller	Closed centrifugal type (Twin)
	Shaft seal type	Mechanical seal
	Bearing	Sealed ball bearing
Pipe Connection	Suction [inch]	from G 1 ¹ / ₄ to G 1 ¹ / ₂ (2CDX 200) UNI ISO 228-1
	Discharge [inch]	G 1" UNI ISO 228-1
Material	Casing	EN 1.4301 (AISI 304) - (AISI 316 only for "L" version)
	Impeller	EN 1.4301 (AISI 304) - (AISI 316 only for "L" version)
	Casing cover	EN 1.4301 (AISI 304) - (AISI 316 only for "L" version)
	Shaft seal	Ceramic/Carbon/NBR (for version see page 301)
	Shaft	AISI 304 / AISI 316 (Wet extension)
	Bracket	Aluminium (up to 1.5 kW included) Cast iron (2.2 kW and above)
Diffuser		AISI 304 / AISI 316
Applicable standard of test		ISO 9906:2012 – Grade 3B

MOTOR		
Type	Electric - TEFC	
	Single Phase	Three Phase
Efficiency level (Reg. 640/2009)	-	IE2 from 0.75 kW up to 4.0 kW IE3 from 0.75 kW up to 4.0 kW
No. of Poles	2	
Rotation speed [min ⁻¹]	≈ 2800	
Insulation Class	F	
Protection degree (CEI EN 60034-5)	IP 55	
Power rating [kW]	0.75 ÷ 2.2	0.75 ÷ 3.7
	[HP]	1 ÷ 2
Frequency [Hz]	50	
Voltage [V]	230 ±10%	230/400 ±10%
Capacitor	Built in	-
Over load protection	Built in	Provided by the user
Casing material	Aluminium	
Motor support	Aluminium	
Dimensions of cable entry	PG 11 – PG 13.5 – PG 16 - M16x1.5 - M20x1.5 (see dimensions page 400)	

200

CENTRIFUGAL PUMPS

2CDX

SELECTION CHART

50Hz

Rev. M

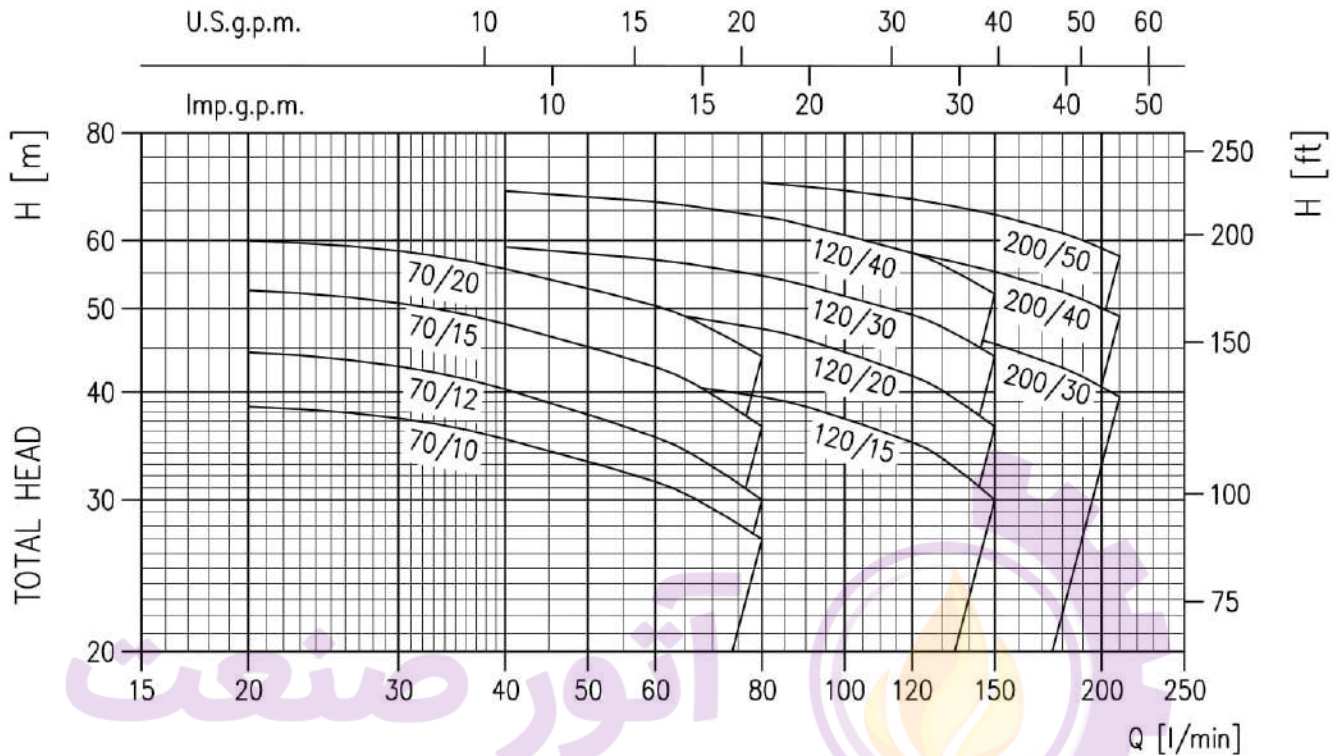

Pump Type		Power		Q=Capacity									
Single Phase	Three Phase	[kW]	[HP]	l/min	0	20	40	60	80	120	150	180	210
				m ³ /h	0	1.2	2.4	3.6	4.8	7.2	9.0	10.8	12.6
H=Total manometric head in meters													
2CDXM 70/10	2CDX 70/10	0.75	1	41	38.5	35.3	31.5	27	-	-	-	-	-
2CDXM 70/12	2CDX 70/12	0.9	1.2	48	44.5	40.3	35.5	30	-	-	-	-	-
2CDXM 70/15	2CDX 70/15	1.1	1.5	56	52.5	48	42.8	36.5	-	-	-	-	-
2CDXM 70/20	2CDX 70/20	1.5	2	64	60	55.6	50.4	44	-	-	-	-	-
2CDXM 120/15	2CDX 120/15	1.1	1.5	46	-	42	41	39.5	35	30	-	-	-
2CDXM 120/20	2CDX 120/20	1.5	2	55	-	51.5	49.5	47.4	41.8	36.5	-	-	-
-	2CDX 120/30	2.2	3	63	-	59	57	54.6	49.2	44	-	-	-
-	2CDX 120/40	3	4	71.5	-	68.5	66.5	64	58	52	-	-	-
-	2CDX 200/30	2.2	3	55	-	-	52	50.8	48.1	45.5	42.7	39.5	-
-	2CDX 200/40	3	4	66	-	-	62.5	61.1	58	55.2	52.3	49	-
-	2CDX 200/50	3.7	5	75	-	-	71.5	70.1	67	64.3	61.2	57.5	-

CENTRIFUGAL PUMPS

2CDX

TYPE KEY AND CURVE SPECIFICATIONS

50Hz

Rev. M

TYPE KEY

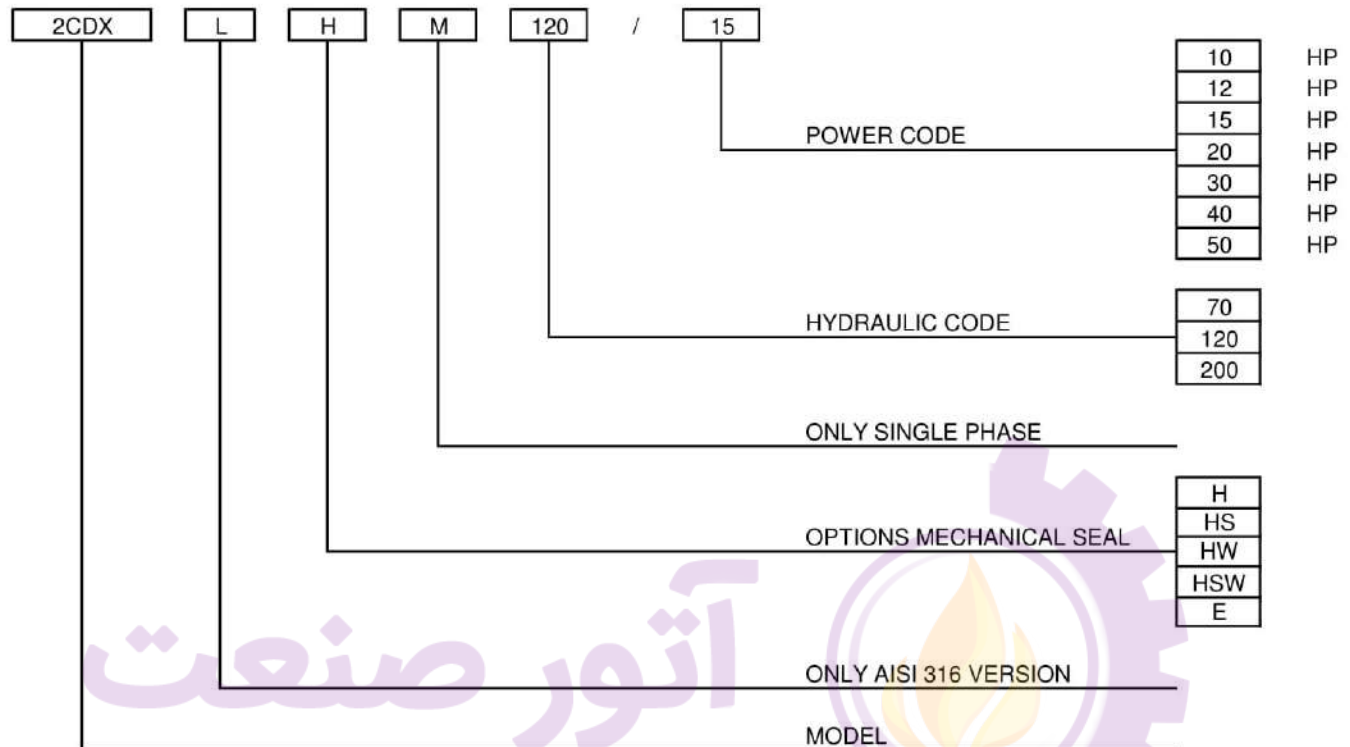

PERFORMANCE CURVE SPECIFICATIONS

The specifications below qualify the curves shown on the following pages.

Tolerances according to ISO 9906:2012 - Grade 3B

The curves refer to effective speed of asynchronous motors at 50 Hz, 2 poles.

Measurements were carried out with clean water at 20°C of temperature and with a kinematic viscosity of $\nu = 1 \text{ mm}^2/\text{s}$ (1 cSt)

The NPSH curve is an average curve obtained in the same conditions of performance curves.

The continuous curves indicate the recommended working range. The dotted curve is only a guide.

In order to avoid the risk of over-heating, the pumps should not be used at a flow rate below 10% of best efficiency point.

Symbols explanation:

- Q = volume flow rate
- H = total head
- P_2 = pump power input (shaft power)
- η = pump efficiency
- NPSH = net positive suction head required by the pump

CENTRIFUGAL PUMPS

2CDX

PERFORMANCE CURVE

50Hz

Rev. M

2CDX 70/10 (0.75 kW) - Impeller diameter = 132/132 mm
 2CDX 70/12 (0.9 kW) - Impeller diameter = 153/132 mm
 2CDX 70/15 (1.1 kW) - Impeller diameter = 153/153 mm
 2CDX 70/20 (1.5 kW) - Impeller diameter = 153/176 mm

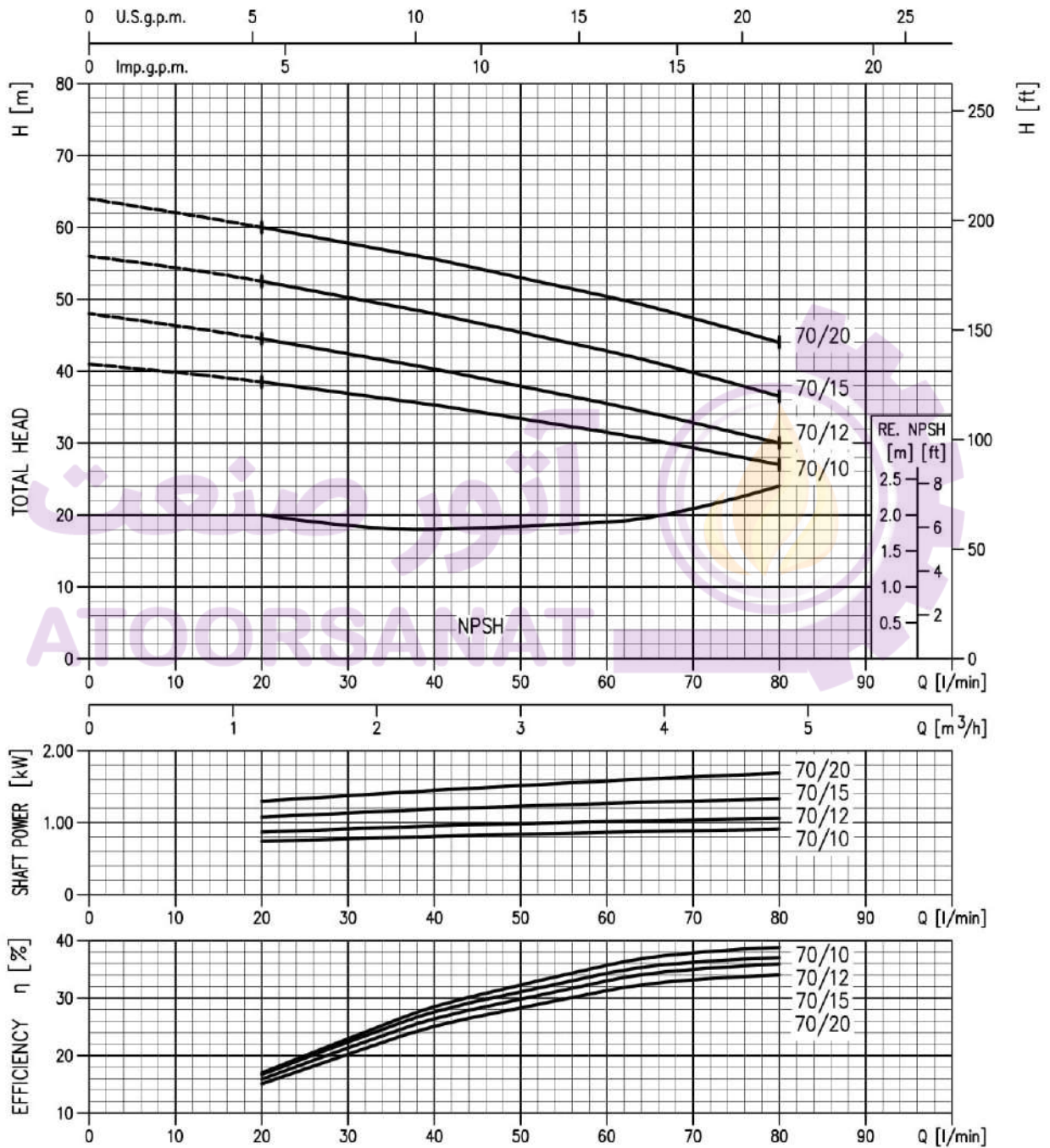

Rotation speed $\approx 2800 \text{ min}^{-1}$
 Test standard: ISO 9906:2012 - Grade 3B

CENTRIFUGAL PUMPS

2CDX

PERFORMANCE CURVE

50Hz

Rev. M

2CDX 120/15 (1.1 kW) - Impeller diameter = 132/132 mm
 2CDX 120/20 (1.5 kW) - Impeller diameter = 157/132 mm
 2CDX 120/30 (2.2 kW) - Impeller diameter = 157/157 mm
 2CDX 120/40 (3.0 kW) - Impeller diameter = 176/157 mm

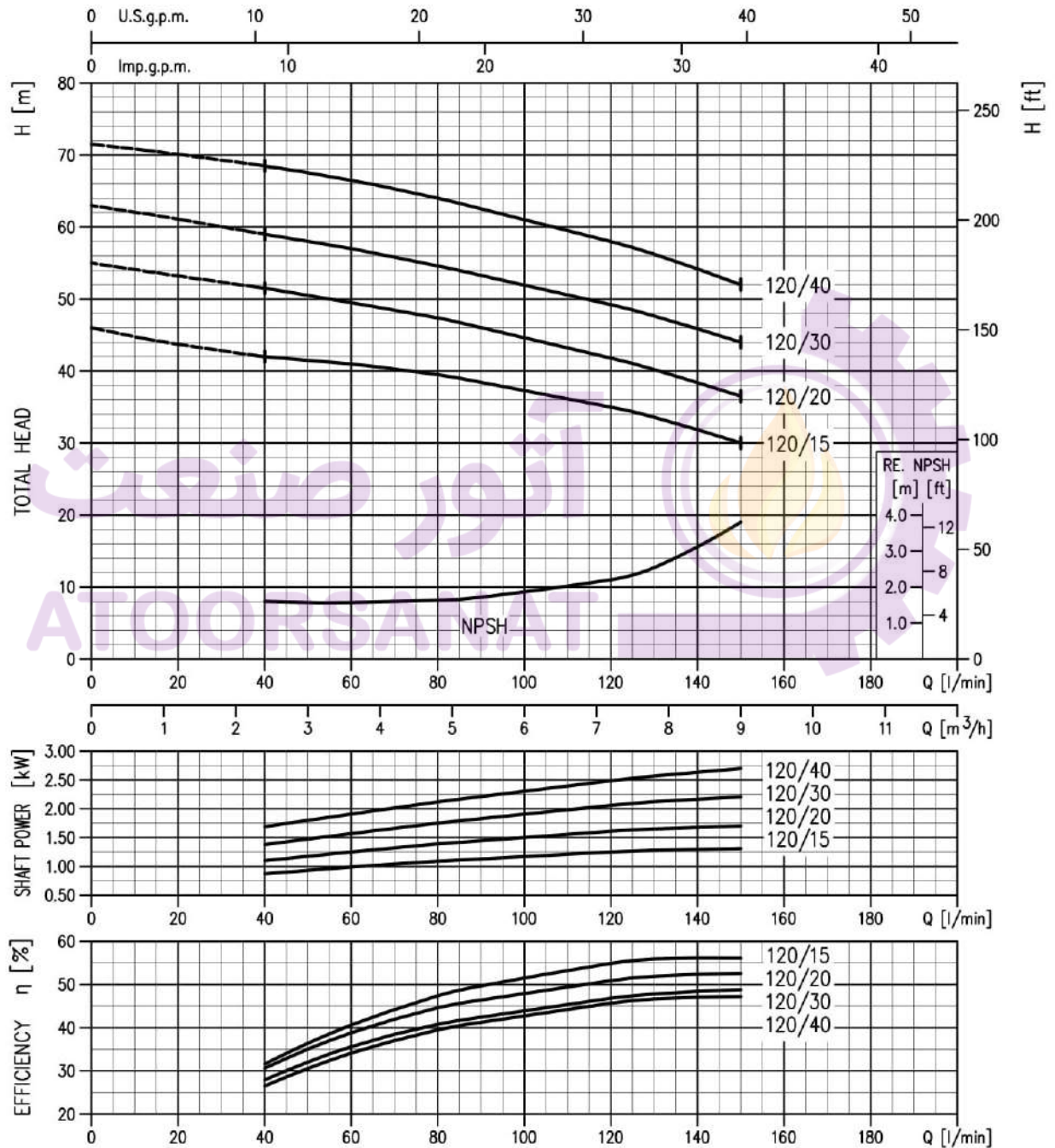

Rotation speed ≈ 2800 min⁻¹
 Test standard: ISO 9906:2012 - Grade 3B

CENTRIFUGAL PUMPS

2CDX

PERFORMANCE CURVE

50Hz

Rev. M

2CDX 200/30 (2.2 kW) - Impeller diameter = 157/132 mm
 2CDX 200/40 (3.0 kW) - Impeller diameter = 157/157 mm
 2CDX 200/50 (3.7 kW) - Impeller diameter = 176/157 mm

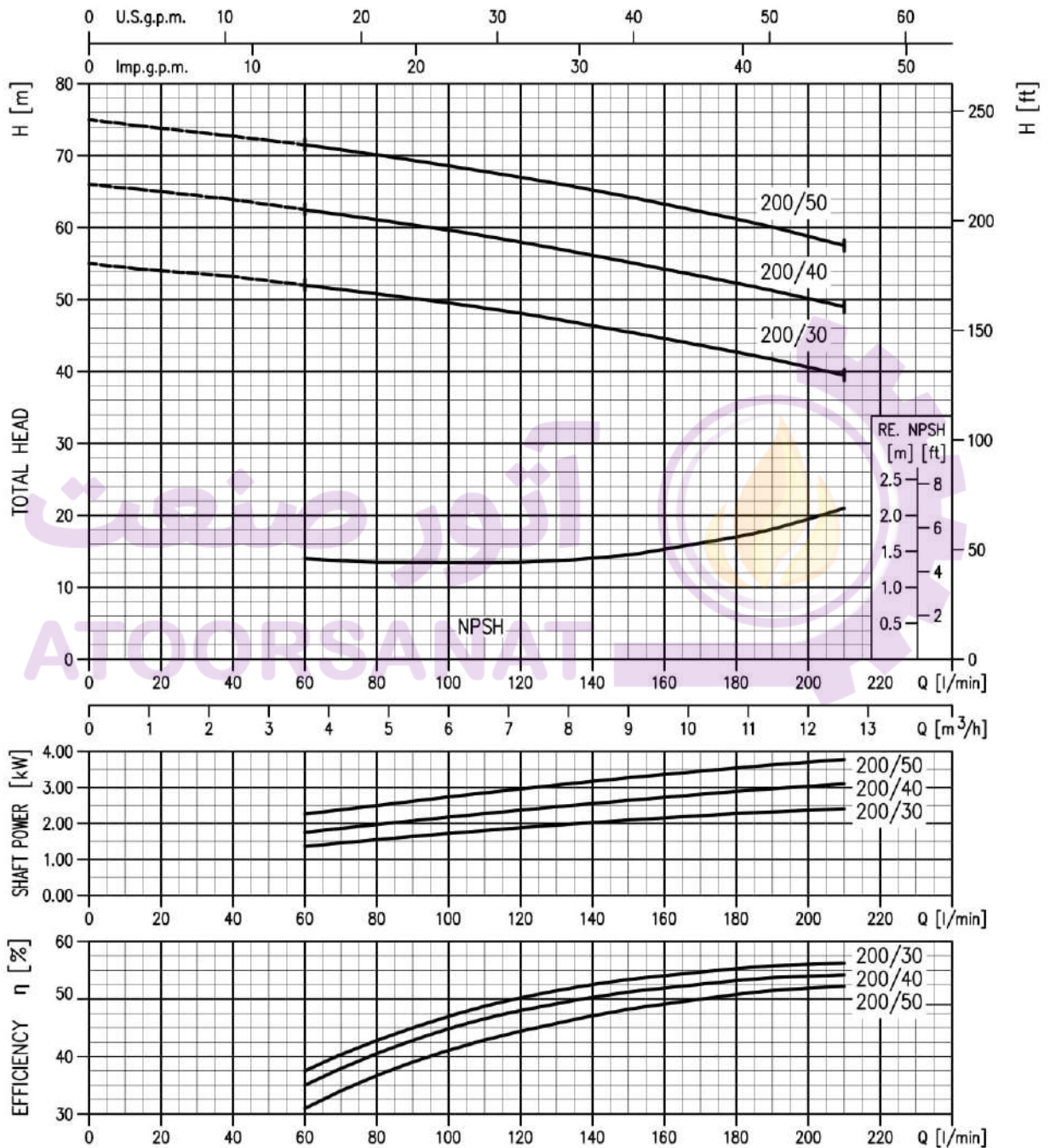

Rotation speed $\approx 2800 \text{ min}^{-1}$
 Test standard: ISO 9906:2012 - Grade 3B

SECTIONAL VIEW

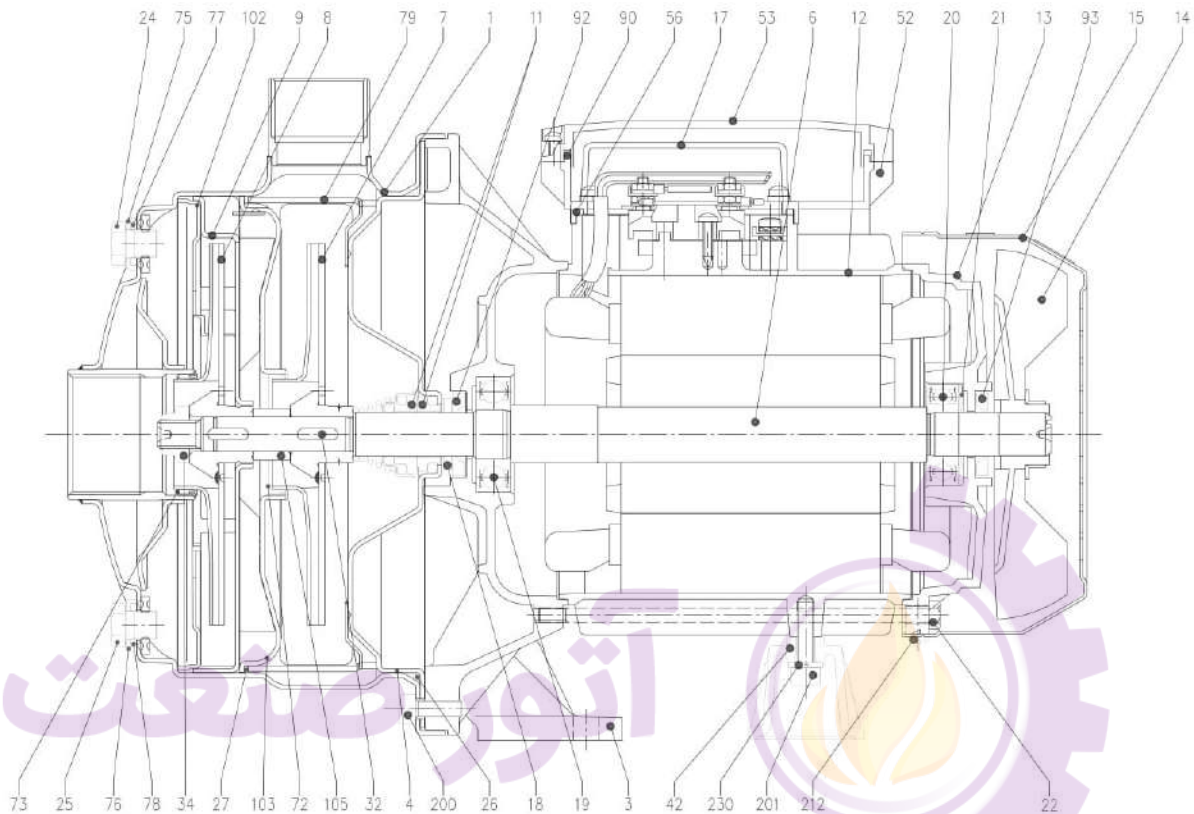

N°	PART NAME	MATERIAL	DIMENSION	STANDARD	Q.TY	N°	PART NAME	MATERIAL	DIMENSION	STANDARD	Q.TY	
1	Casing	AISI 304 / AISI 316 [6]			1	42	Motor support	Aluminium			1	
3	Motor bracket	[4]			1	52	Capacitor box [1]	ABS class V-0			1	
4	Casing cover	AISI 304 / AISI 316 [6]			1	53	Capacitor box cover [1]	ABS class V-0			1	
6	Shaft with rotor	AISI 303 / AISI 316 [6] (Wet extension)			1	56	Box gasket	NBR			1	
7	Impeller	AISI 304 / AISI 316 [6]			1	72	Casing ring [5]	NBR			1	
8	Impeller	AISI 304 / AISI 316 [6]			1	73	Casing ring [5]	NBR			1	
9	Diffuser	AISI 304 / AISI 316 [6]			1	75	Washer	AISI 304			1	
11	Mechanical seal	Ceramic/Carbon/NBR	see page 301		1	76	Washer	AISI 304			1	
12	Motor frame with stator	-			1	77	O-ring [3]	NBR			1	
13	Motor cover	Aluminium			1	78	O-ring [3]	NBR			1	
14	Fan	PA			1	79	Space diffuser	AISI 304 / AISI 316 [6]			1	
15	Fan cover	Fe P04 Galvanized			1	90	Terminal box cover gasket [1]	NBR			1	
17	Terminal box cover [2]	Aluminium			1	92	Lip seal	NBR			1	
18	Splash ring	NBR			1	93	Lip seal	NBR			1	
19	Pump side ball bearing	-			1	102	Suction cover	AISI 304 / AISI 316 [6]			1	
20	Fan side ball bearing	-			1	103	Conveyor cover	AISI 304 / AISI 316 [6]			1	
21	Adjusting ring	Steel C70			1	105	Sleeve	AISI 304 / AISI 316 [6]			1	
22	Tie rod	Fe 420 Galvanized			4	200	Screw	70/10, 120/15, 120/20, 200/30 70/12, 70/15, 70/20, 120/30, 120/40, 200/40, 200/50	M6X16 M8X18	UNI 5931	8	
24	Priming plug	AISI 304 / AISI 316 [6]			1	201	Screw	Zn. Steel cl.8.8			UNI 5931	1
25	Drain plug	AISI 304 / AISI 316 [6]			1	212	Screw	Stainless steel A2	3,5X9,5		UNI 6954	4
26	O-ring [3]	NBR			1	230	Washer	Steel C70	6.4		UNI 1751	1
27	O-ring [3]	NBR			1							
32	Key	AISI 316			2							
34	Impeller nut	Stainless steel A2-70	M10X1,25	UNI 7474	1							

- [1] Only for single phase
- [2] Only for three phase
- [3] FPM for H-HS-HW-HSW
EPDM for E
- [4] Material: Aluminium for version up to 1.5 kW included
Cast iron for version 2.2 kW and above
- [5] FPM for H-HS-HW-HSW
NBR for E
- [6] Only for "L" version

THERMAL INSULATION

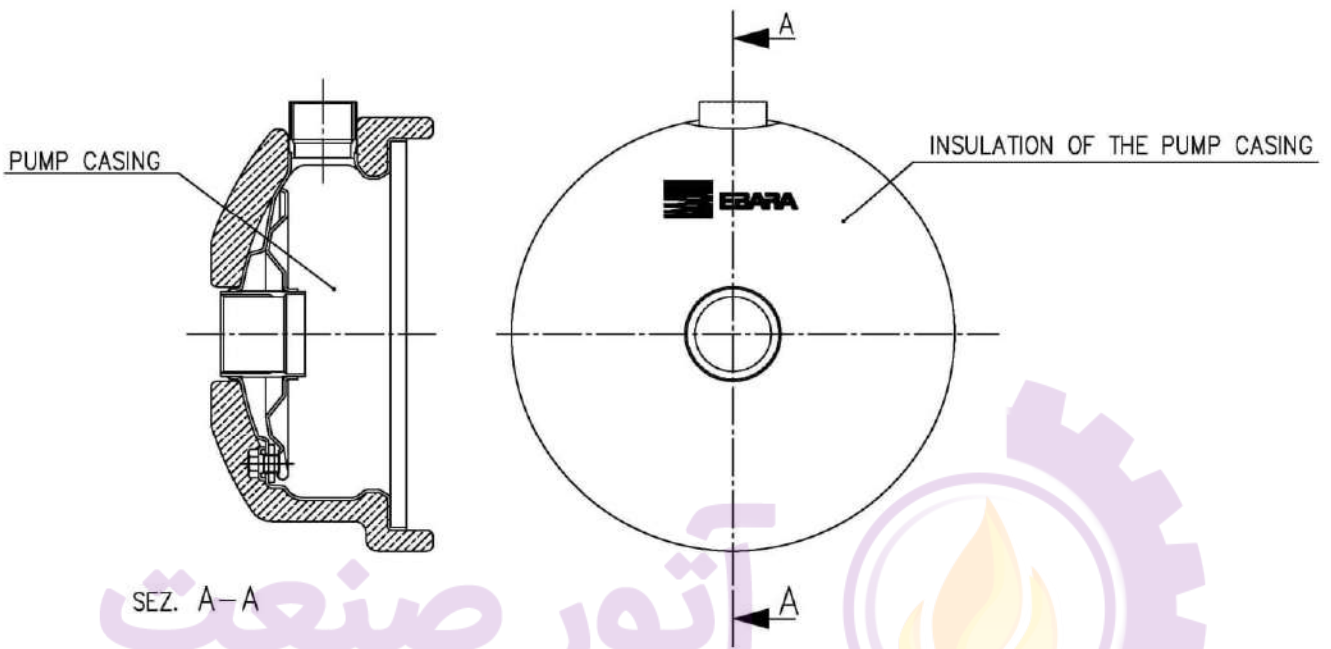

آتور صنعت
ATOORSANAT

Pump Type	Insulation of the pump casing
2CDX 70/10	ON REQUEST
2CDX 70/12	
2CDX 70/15	
2CDX 70/20	
2CDX 120/15	
2CDX 120/20	
2CDX 120/30	
2CDX 120/40	
2CDX 200/30	
2CDX 200/40	
2CDX 200/50	

CENTRIFUGAL PUMPS

2CDX

CONSTRUCTION

50Hz

Rev. M

MECHANICAL SEAL

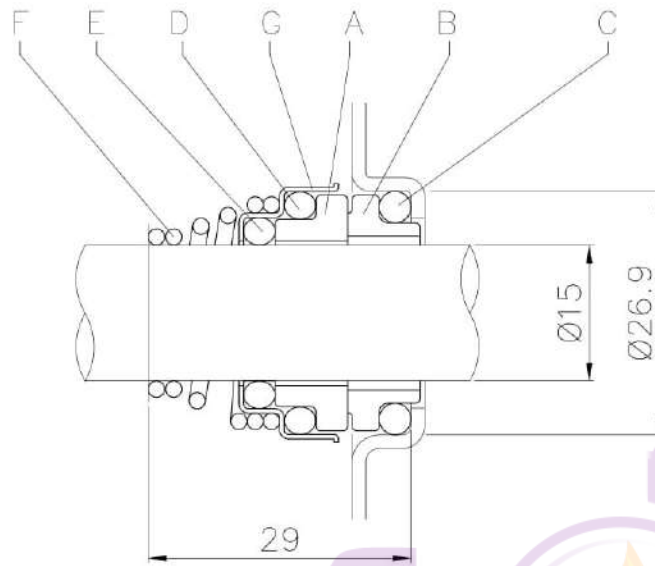

REF	PART NAME	Standard version	MATERIAL				
			(H)	(HS)	Optional (HW)	(HSW)	(E)
A	Rotary seal ring	Ceramic	Ceramic	Silicon carbide	Tungsten carbide	Silicon carbide	Ceramic
B	Stationary seal ring	Carbon graphite	Carbon graphite	Silicon carbide	Tungsten carbide	Tungsten carbide	Carbon graphite
C	O Ring	NBR	FPM	FPM	FPM	FPM	EPDM
D	O Ring	NBR	FPM	FPM	FPM	FPM	EPDM
E	O Ring	NBR	FPM	FPM	FPM	FPM	EPDM
F	Self driving spring	AISI 316	AISI 316	AISI 316	AISI 316	AISI 316	AISI 316
G	Frame	AISI 304	AISI 304	AISI 316	AISI 316	AISI 316	AISI 316

BEARINGS

Pump type		Ball Bearing			
Single Phase	Three Phase	Pump side	(**)		Fan side
			Pump side	Fan side	
2CDXM 70/10	2CDX 70/10	6203 2RSH	6203-ZZ C3	6202 2RSH	6202-ZZ C3
2CDXM 70/12	2CDX 70/12	6203 2RSH	6203-ZZ C3	6202 2RSH	6202-ZZ C3
2CDXM 70/15	2CDX 70/15	6204 2RSH	6204-ZZ C3	6203 2RSH	6203-ZZ C3
2CDXM 70/20	2CDX 70/20	6204 2RSH	6204-ZZ C3	6203 2RSH	6203-ZZ C3
2CDXM 120/15	2CDX 120/15	6204 2RSH	6204-ZZ C3	6203 2RSH	6203-ZZ C3
2CDXM 120/20	2CDX 120/20	6204 2RSH	6204-ZZ C3	6203 2RSH	6203-ZZ C3
-	2CDX 120/30	6305 2RSH	6305-ZZ C3	6205 2RSH	6205-ZZ C3
-	2CDX 120/40	6305 2RSH	6305-ZZ C3	6205 2RSH	6205-ZZ C3
-	2CDX 200/30	6205 2RSH	6205-ZZ C3	6205 2RSH	6205-ZZ C3
-	2CDX 200/40	6305 2RSH	6305-ZZ C3	6205 2RSH	6205-ZZ C3
-	2CDX 200/50	6206 2RSH	6206-ZZ C3	6205 2RSH	6205-ZZ C3

(**) Only for IE3 Motors

CENTRIFUGAL PUMPS

DIMENSIONS AND WEIGHT

50Hz

Rev. M

PUMP

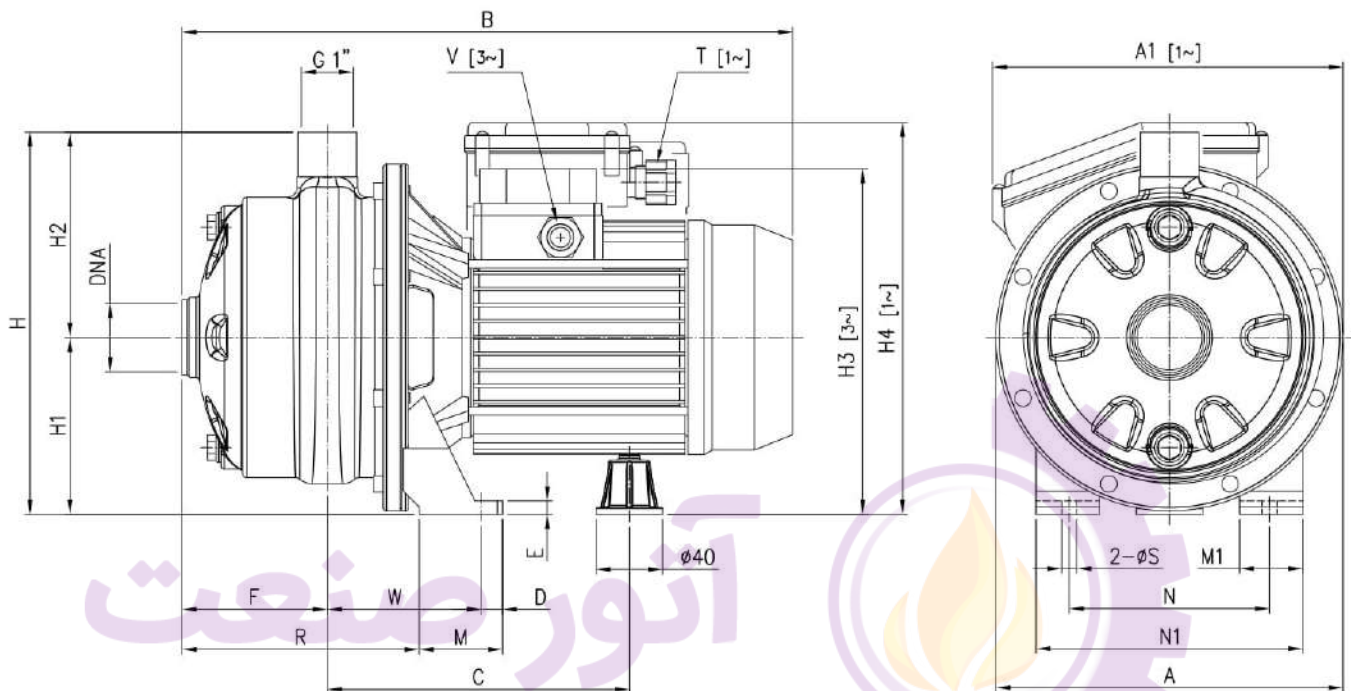

Pump type	A	(*) A1				B	(**) B				C	D	E	F	H	H1	H2	H3	H3 (**)	H4	M	M1	N	N1	R	T	V	(**) V		W	S	DNA	Weight [kg]		
		[1~]	[1~]	[3~]	[3~]		[3~]	[3~]	[3~]	[3~]																		[1~]	[3~]				[1~]	[3~]	[1~]
70/10	208	-	355	354	354	181	181	12.5	8	87	229	106	123	207	207	218	50	38	120	160	142	PG 11	PG 11	M16x1.5	92.5	9	G1½	12.7	12.6	12.6					
70/12	208	210	355	366	366	181	181	12.5	8	87	229	106	123	207	207	235	50	38	120	160	142	PG 13.5	PG 11	M16x1.5	92.5	9	G1½	13.3	13.7	13.7					
70/15	232	-	395.5	382	407	198.5	198.5	12.5	8	89	250	118	132	237	237	248.5	55	40	140	180	141.5	PG 13.5	PG 11	M20x1.5	95	9	G1½	17.5	17	17					
70/20	232	-	382.5	395	407.5	198.5	198.5	12.5	8	89	250	118	132	237	237	248.5	55	40	140	180	141.5	PG 13.5	PG 11	M20x1.5	95	9	G1½	18.5	19.2	20.1					
120/15	208	210	395.5	382	407	198.5	198.5	12.5	8	89	229	106	123	225	225	236.5	55	40	140	180	141.5	PG 13.5	PG 11	M20x1.5	95	9	G1½	16.3	15.6	15.6					
120/20	208	210	382.5	395	407.5	198.5	198.5	12.5	8	89	229	106	123	225	225	236.5	55	40	140	180	141.5	PG 13.5	PG 11	M20x1.5	95	9	G1½	17	17.4	18.9					
120/30	232	-	419	405	223.5 + 234.5	198.5	198.5	12.5	10	87	250	118	132	242	237	-	65	40	140	180	143.5	-	PG 13.5	M20x1.5	109	9	G1½	-	25.2	26.1					
120/40	232	-	458	458	223.5 + 234.5	223.5 + 234.5	223.5 + 234.5	12.5	10	87	250	118	132	242	242	-	65	40	140	180	143.5	-	PG 13.5	M20x1.5	109	9	G1½	-	27.8	27.8					
200/30	208	-	458	458	223.5 + 234.5	223.5 + 234.5	223.5 + 234.5	12.5	10	87	229	106	123	230	230	-	65	40	140	180	143.5	-	PG 13.5	M20x1.5	109	9	G1½	-	25.7	25.6					
200/40	232	-	458	458	223.5 + 234.5	223.5 + 234.5	223.5 + 234.5	12.5	10	87	250	118	132	242	242	-	65	40	140	180	143.5	-	PG 13.5	M20x1.5	109	9	G1½	-	27.6	27.6					
200/50	232	-	481	481	232.5	232.5	16	12	87	250	118	132	259	259	-	68	50	160	210	143.5	-	PG 16	M20x1.5	108.5	12	G1½	-	35.6	35.6						

(*) Specified only if higher than "A"

(**) Only for IE3 Motors

[1~] Single phase

[3~] Three phase

CENTRIFUGAL PUMPS

2CDX

DIMENSIONS AND WEIGHT

50Hz

Rev. M

PACKING

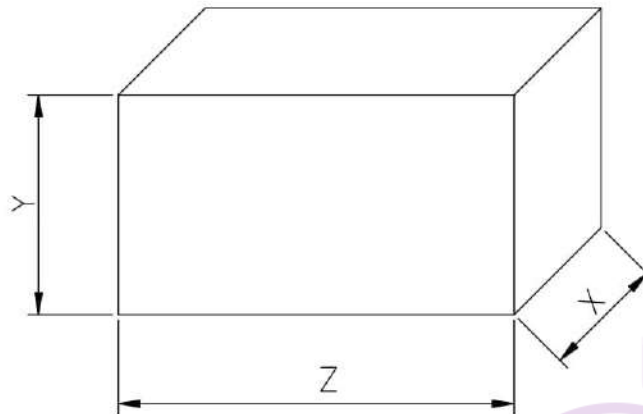

Pump type		Packing [mm]						Weight [kgf]		
Single Phase	Three Phase	X		Y		Z		[1~]	[3~]	(**)
		[1~]	[3~]	[1~]	[3~]	[1~]	[3~]	[1~]	[3~]	[3~]
2CDXM 70/10	2CDX 70/10	237	237	280	280	445	445	13.3	13.3	13.3
2CDXM 70/12	2CDX 70/12	237	237	280	285	445	500	13.9	14.6	14.6
2CDXM 70/15	2CDX 70/15	237	237	285	285	500	500	18.4	17.8	17.8
2CDXM 70/20	2CDX 70/20	237	237	285	285	500	500	19.5	20.1	21
2CDXM 120/15	2CDX 120/15	237	237	285	285	500	500	17	16.4	16.4
2CDXM 120/20	2CDX 120/20	237	237	285	285	500	500	17.7	18.4	19.3
-	2CDX 120/30	-	237	-	285	-	500	-	25.8	26.7
-	2CDX 120/40	-	237	-	285	-	585	-	28.8	28.8
-	2CDX 200/30	-	237	-	285	-	585	-	27.6	28.5
-	2CDX 200/40	-	237	-	285	-	585	-	28.6	28.6
-	2CDX 200/50	-	237	-	285	-	585	-	37.5	37.5

[1~] Single phase

[3~] Three phase

CENTRIFUGAL PUMPS

2CDX

TECHNICAL DATA

50Hz

Rev. M

MOTOR DATA

Pump type		Power		Efficiency		Capacitor		Efficiency (% load)			Input [kW]		Full load current [A]			Locked rotor current [A]		
Single Phase	Three Phase	[kW]	[HP]	Single Phase	Three Phase	Single Phase [μF]	Three Phase [V]	Three phase η %			Single Phase	Three Phase	Single Phase 230 V	Three Phase 230 V	400 V	Single Phase 230 V	Three Phase 230 V	400 V
								50%	75%	100%								
2CDXM 70/10	2CDX 70/10	0.75	1.0	-	IE2	20	450	77.2	80.9	81.3	1.30	1.14	6.0	3.6	2.0	22.7	22.0	12.9
-	2CDX 70/10	0.75	1.0	-	IE3	-	-	80.9	82.3	82.1	-	0.91	-	3.0	1.7	-	19.7	11.4
2CDXM 70/12	2CDX 70/12	0.9	1.2	-	IE2	31.5	450	79.0	81.7	81.6	1.55	1.35	7.0	4.3	2.5	25.5	31.0	17.8
-	2CDX 70/12	0.9	1.2	-	IE3	-	-	81.7	83.1	82.4	-	1.34	-	4.3	2.5	-	28.8	16.6
2CDXM 70/15	2CDX 70/15	1.1	1.5	-	IE2	40	450	79.7	82.5	83.0	1.80	1.80	8.1	5.6	3.2	43.0	45.0	25.7
-	2CDX 70/15	1.1	1.5	-	IE3	-	-	83.0	85.8	85.6	-	1.77	-	5.8	3.3	-	47.4	27.4
2CDXM 70/20	2CDX 70/20	1.5	2.0	-	IE2	40	450	80.3	83.4	83.8	2.30	2.28	10.0	7.4	4.3	43.0	34.3	20.0
-	2CDX 70/20	1.5	2.0	-	IE3	-	-	84.2	86.8	86.9	-	2.01	-	7.1	4.1	-	66.6	38.4
2CDXM 120/15	2CDX 120/15	1.1	1.5	-	IE2	40	450	79.7	82.5	83.0	1.80	1.80	8.3	5.6	3.2	43.0	45.0	25.7
-	2CDX 120/15	1.1	1.5	-	IE3	-	-	83.0	85.8	85.6	-	1.77	-	5.8	3.3	-	47.4	27.4
2CDXM 120/20	2CDX 120/20	1.5	2.0	-	IE2	40	450	80.3	83.4	83.8	2.35	2.28	10.2	7.3	4.2	43.0	34.3	20.0
-	2CDX 120/20	1.5	2.0	-	IE3	-	-	84.2	86.8	86.9	-	2.01	-	7.1	4.1	-	66.6	38.4
-	2CDX 120/30	2.2	3.0	-	IE2	-	-	83.1	85.7	86.2	-	2.90	-	8.8	5.1	-	75.0	43.5
-	2CDX 120/30	2.2	3.0	-	IE3	-	-	86.2	87.0	86.0	-	2.55	-	8.2	4.7	-	66.6	38.4
-	2CDX 120/40	3.0	4.0	-	IE2	-	-	85.0	86.7	86.3	-	3.48	-	10.6	6.1	-	100.0	57.7
-	2CDX 120/40	3.0	4.0	-	IE3	-	-	85.9	87.5	87.1	-	3.44	-	11.1	6.4	-	90.0	52.0
-	2CDX 200/30	2.2	3.0	-	IE2	-	-	85.0	86.7	86.3	-	3.48	-	10.6	6.1	-	100.0	57.7
-	2CDX 200/30	2.2	3.0	-	IE3	-	-	85.9	87.5	87.1	-	3.44	-	11.1	6.4	-	90.0	52.0
-	2CDX 200/40	3.0	4.0	-	IE2	-	-	85.0	86.7	86.3	-	3.83	-	11.6	6.7	-	100.0	57.7
-	2CDX 200/40	3.0	4.0	-	IE3	-	-	85.9	87.5	87.1	-	3.44	-	11.1	6.4	-	90.0	52.0
-	2CDX 200/50	3.7	5.0	-	IE2	-	-	84.3	87.2	87.8	-	4.56	-	15.1	8.7	-	151.0	87.0
-	2CDX 200/50	3.7	5.0	-	IE3	-	-	85.8	88.3	88.4	-	4.52	-	15.1	8.7	-	131.8	76.1

ATOORSANAT

NOISE DATA

Pump type		Power		L _{pA} - dB(A) *
Single Phase	Three Phase	[kW]	[HP]	
2CDXM 70/10	2CDX 70/10	0.75	1.0	62
2CDXM 70/12	2CDX 70/12	0.9	1.2	
2CDXM 70/15	2CDX 70/15	1.1	1.5	
2CDXM 70/20	2CDX 70/20	1.5	2.0	64
2CDXM 120/15	2CDX 120/15	1.1	1.5	
2CDXM 120/20	2CDX 120/20	1.5	2.0	68
-	2CDX 120/30	2.2	3.0	
-	2CDX 120/40	3.0	4.0	
-	2CDX 200/30	2.2	3.0	
-	2CDX 200/40	3.0	4.0	
-	2CDX 200/50	3.7	5.0	

* Mean value of several measures at 1m distance around the pump.
Tolerance ± 2.5 dB.

500