





## SUBMERSIBLE SEWAGE PUMPS

# RIGHT

### CONTENTS

50Hz

Rev. H

	<b>Page</b>
<b>- SPECIFICATIONS</b>	<b>200</b>
SELECTION CHART	201
TYPE KEY	202
CURVE SPECIFICATIONS	203
PERFORMANCE CURVE RIGHT 75	204
PERFORMANCE CURVE RIGHT 100	205
<b>- CONSTRUCTIONS</b>	<b>300</b>
SECTIONAL VIEW	300
BEARINGS	301
MECHANICAL SEALS	301
<b>- DIMENSIONS AND WEIGHT</b>	<b>400</b>
PUMP	400
PACKING	401
<b>- TECHNICAL DATA</b>	<b>500</b>
<b>- INSTALLATION</b>	<b>600</b>

آتور صنعت  
ATOORSANAT

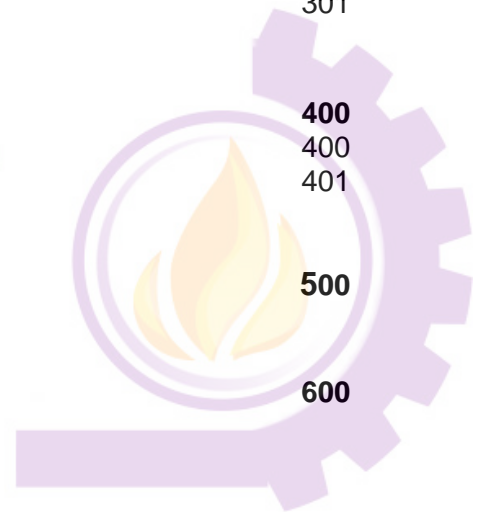

**SUBMERSIBLE SEWAGE PUMPS**

**SPECIFICATION**

50Hz

Rev. H

PUMP		
Liquid Handled	Type of liquid	Clean and dirty water
	Max [°C]	50°
	Max solids size [mm]	35 spherical
Maximum immersion [m]		2 (with power cable length 5 m ) 7 (with power cable length 10 m )
Construction	Impeller	Open vortex type
	Shaft seal type	Double mechanical seal
	Bearing	Sealed ball bearing
Pipe Connection	Suction-Flange [mm]	35 open
	Discharge- [inch]	G1½ UNI ISO 228
Material	Casing	AISI 304
	Impeller	AISI 304
	Casing cover	AISI 304
	Shaft seal	Pump side: SiC/SiC/NBR Motor side: Carbon/Ceramic/NBR
	Seal cover	AISI 304
	Shaft	AISI 303 (Wet extension)
	Lubricating liquid	White mineral oil: Esso Marcol 152 (180 cc)
Applicable standard of test		ISO 9906 Annex A

MOTOR			
Type	Submersible dry type		
	Single Phase	Three Phase	
No. of Poles	2		
Rotation speed [min <sup>-1</sup> ]	≈ 2875		
Insulation Class	F		
Protection degree	IP X8		
kW/HP Rating	[kW]	0.55 ÷ 0.75	
	[HP]	0.75 ÷ 1	
Frequency [Hz]	50		
Voltage [V]	230 ± 10%	400 ± 10%	
Capacitor	Built in	-	
Over load protection	Built in	User to provide	
Float Switch	Optional	N/A	
Float Switch Cable	Material	H07RN-F	
	Size	3G1	
Power cable	length [m]	5 (only for internal usage); 10	
	material	H07RN-F	H07RN-F
	size	3G1	4G1
Dimensions of cable entry	Cable Gland		

**SUBMERSIBLE SEWAGE PUMPS**

**SELECTION CHART**

50Hz

Rev. H

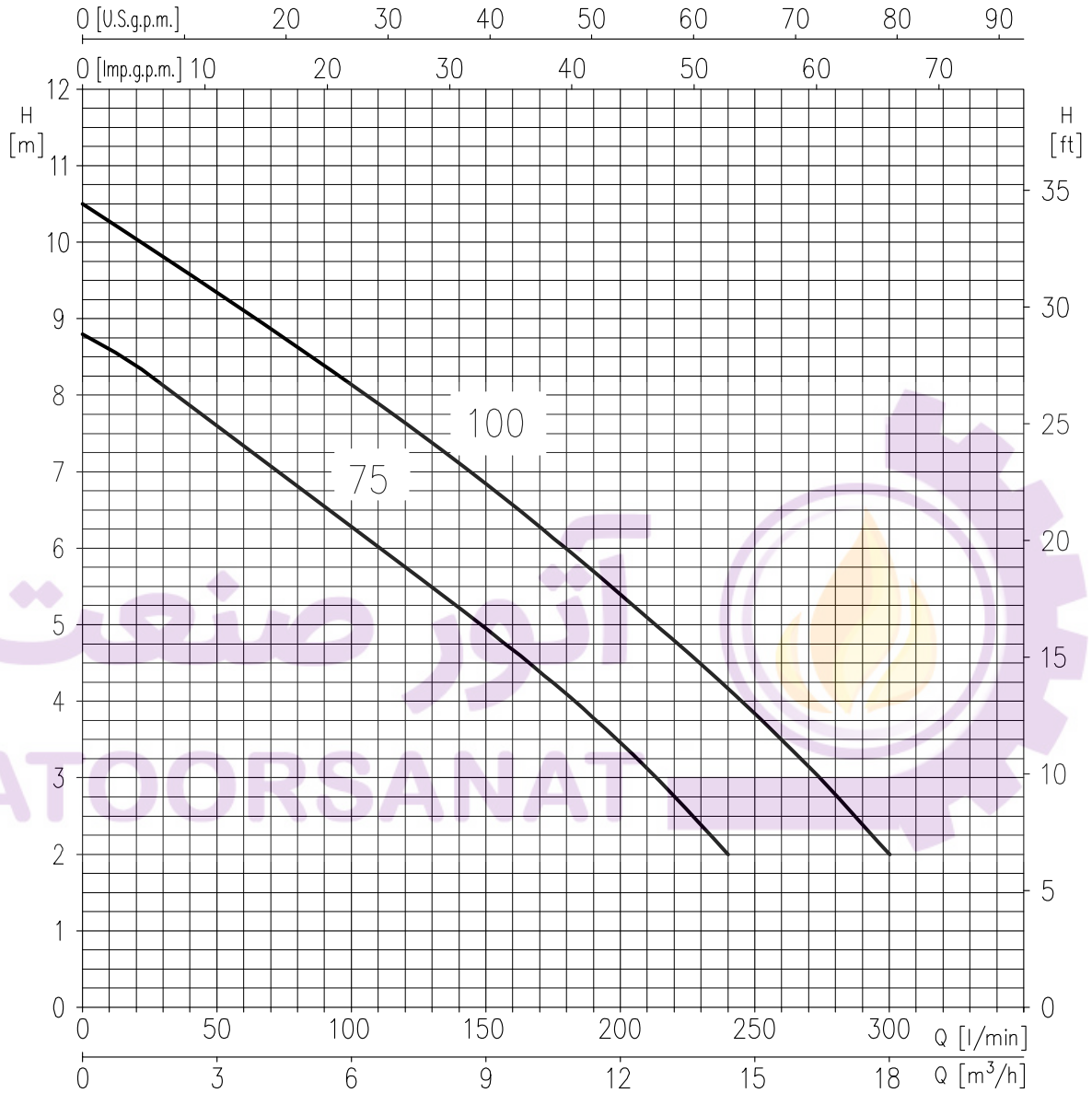

Pump Type		Power		Q=Capacity								
				l/min	0	40	80	120	160	200	240	300
Single Phase	Three Phase	[kW]	[HP]	m <sup>3</sup> /h	0	2,4	4,8	7,2	9,6	12	14,4	18
RIGHT 75 M	RIGHT 75	0,55	0,75	H=Total manometric head in meters								
RIGHT 100M	RIGHT 100	0,75	1	8,8	7,8	6,8	5,7	4,7	3,4	2	-	
				10,5	9,5	8,6	7,6	6,6	5,4	4,2	2	

**SUBMERSIBLE SEWAGE PUMPS**

**PERFORMANCE CURVE**

50Hz

Rev. H

**TYPE KEY:**

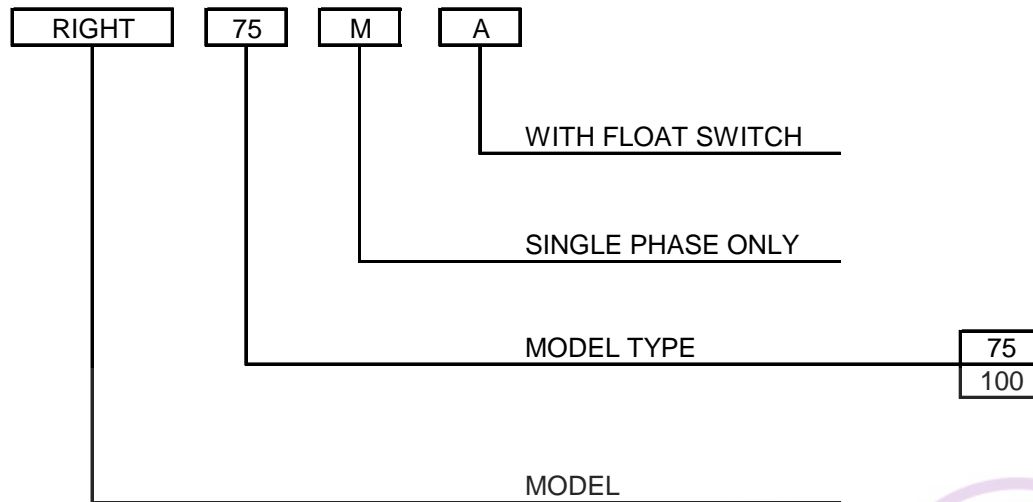

**PERFORMANCE CURVE SPECIFICATIONS**

The specifications below qualify the curves shown on the following pages.

Tolerances according to ISO 9906 Annex A

The curves refer to effective speed of asynchronous motors at 50 Hz

Measurements were carried out with clean water at 20°C of temperature and with a kinematic viscosity of  $\nu = 1 \text{ mm}^2/\text{s}$  (1 cSt)

In order to avoid the risk of over-heating, the pumps should not be used at a flow rate below 10% of best efficiency point.

Symbols explanation:

- Q = volume flow rate
- H = total head

**SUBMERSIBLE SEWAGE PUMPS**

**PERFORMANCE CURVE**

50Hz

Rev. H

**RIGHT 75 (0.55 kW) – impeller diameter = 100 mm**

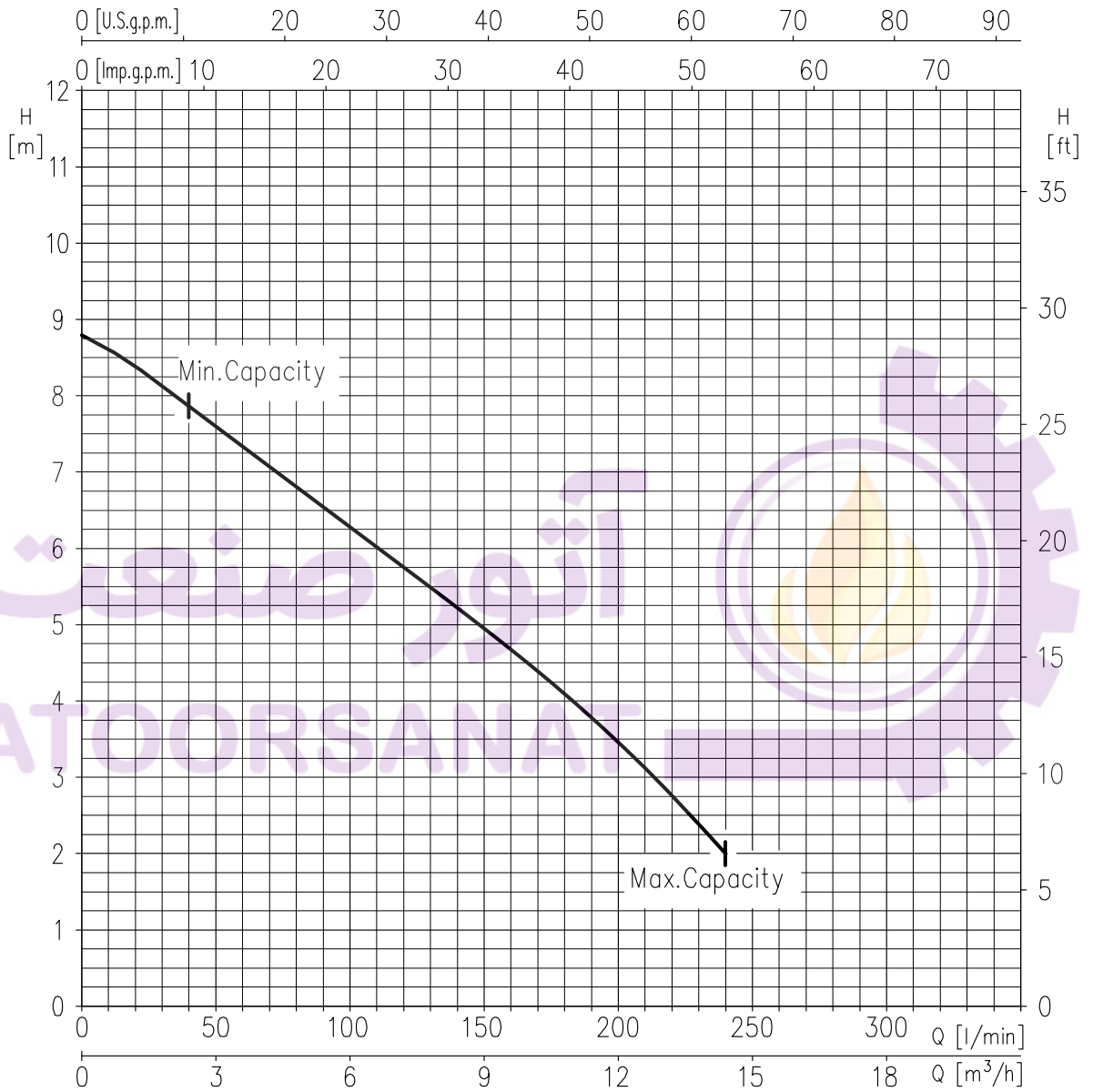

Rotation speed  $\approx 2875 \text{ min}^{-1}$   
Test standard: ISO 9906 – Annex A

**SUBMERSIBLE SEWAGE PUMPS**

**PERFORMANCE CURVE**

50Hz

Rev. H

**RIGHT 100 (0.75 kW) – impeller diameter = 100 mm**

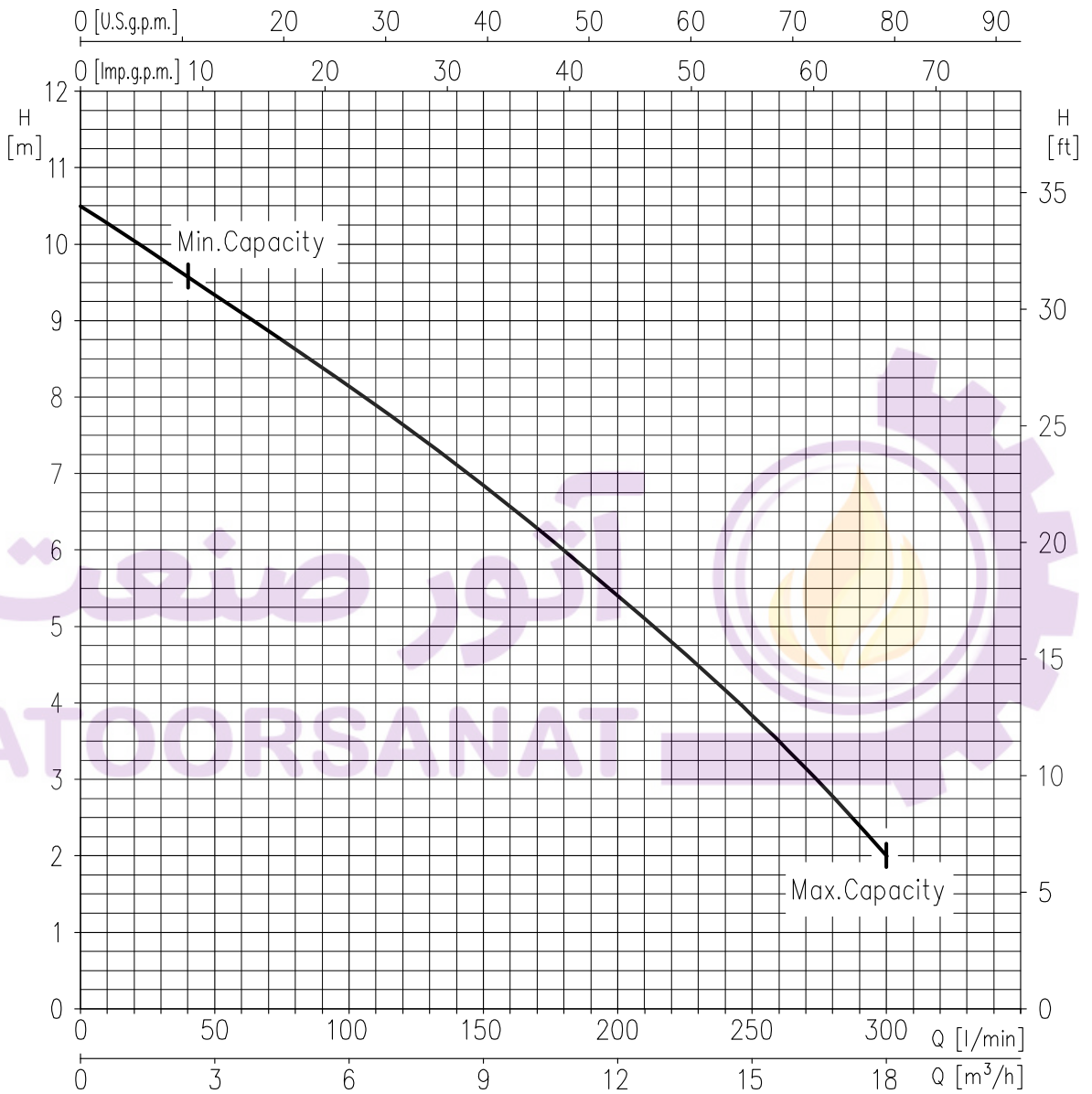

Rotation speed  $\approx 2875 \text{ min}^{-1}$   
Test standard: ISO 9906 – Annex A

**SUBMERSIBLE SEWAGE PUMPS**

**CONSTRUCTION**

50Hz

Rev. H

**SECTIONAL VIEW**

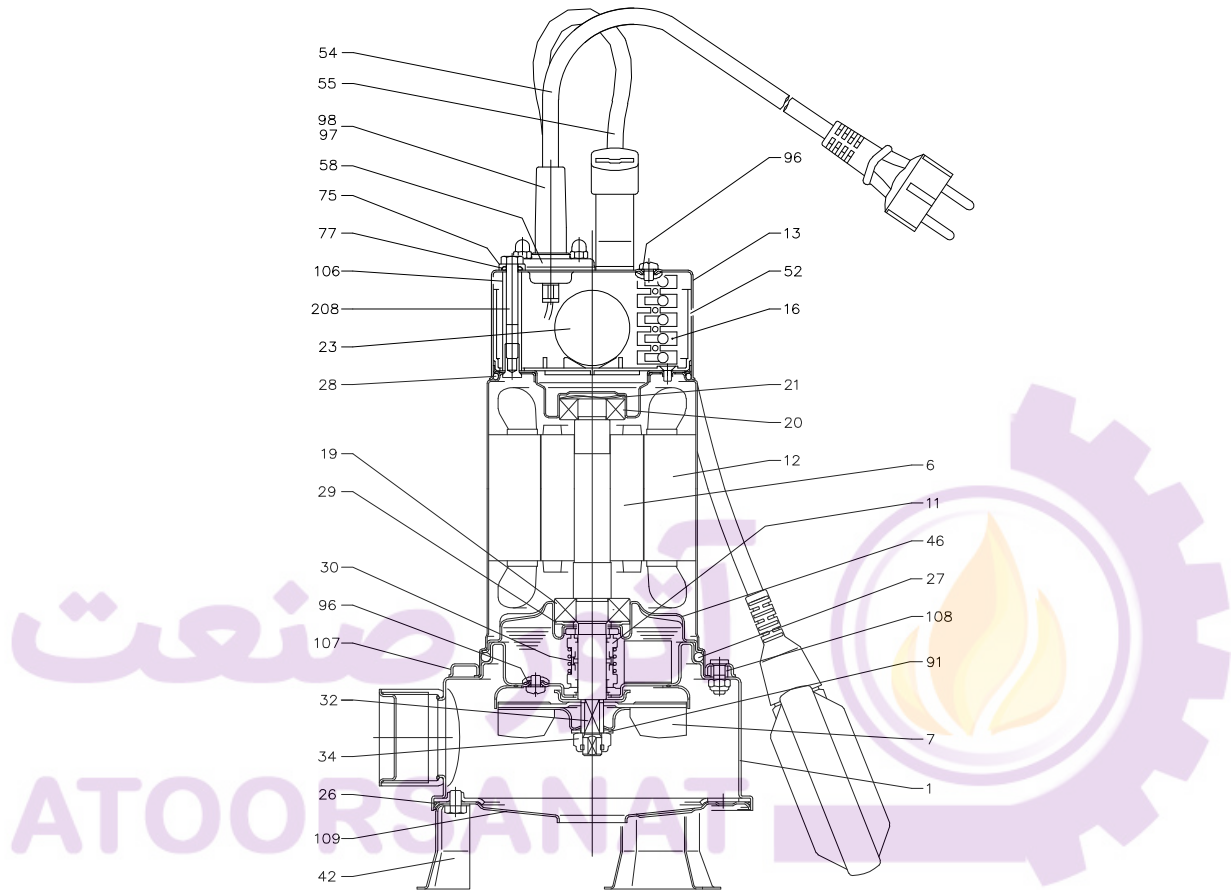

N°	PART NAME	MATERIAL	Q.TY	N°	PART NAME	MATERIAL	Q.TY
1	Casing	A ISI 304	1	42	Foot	A ISI 304	3
6	Shaft w ith rotor	A ISI 303	1	46	Low er bearing bracket	A ISI 304	1
7	Impeller	A ISI 304	1	52	Capacitor box	PA66 glass fibre reinforced class V-0	1
11	Mechanical seal	Ceramic/Carbon/NBR	1	54	Submersible pow er cable	-	1
12	Motor frame w ith stator	-	1	55	Float sw itch [1]	-	1
13	Cover	A ISI 304	1	58	Cable gland	A ISI 304	1
16	Terminal	-	1	75	Washer	A ISI 303	1
19	Low er ball bearing	-	1	77	"O" Ring	NBR	1
20	Upper ball bearing	-	1	91	Washer	A ISI 304	1
21	Adjusting w asher	A ISI 304	1	96	"O" Ring	NBR	1
23	Capacitor [2]	-	1	97	Cable connector	NBR	1
26	"O" Ring	NBR	1	98	Cable connector [1]	NBR	1
27	"O" Ring	NBR	1	106	Spacer	A ISI 304	1
28	"O" Ring	NBR	1	107	Stopper ring	A ISI 304	1
29	Washer	A ISI 304	1	108	Gasket	NBR	1
30	Mechanical seal spacer	Brass	1	109	Suction cover	A ISI 304	1
32	Key	A ISI 304	1	208	Screw	A ISI 304	1
34	Nut	A ISI 303	1	-	-	-	-

[1] Only for single phase version with float switch

[2] Only for single phase version



**SUBMERSIBLE SEWAGE PUMPS**

**CONSTRUCTION**

50Hz

Rev. H

**BEARINGS**

Type pumps		Ball Bearing	
Single Phase	Three Phase	Pump side	Fan side
RIGHT 75 M	RIGHT 75	6203 ZZ	6202 ZZ
RIGHT 100 M	RIGHT 100	6203 ZZ	6202 ZZ

**MECHANICAL SEAL**

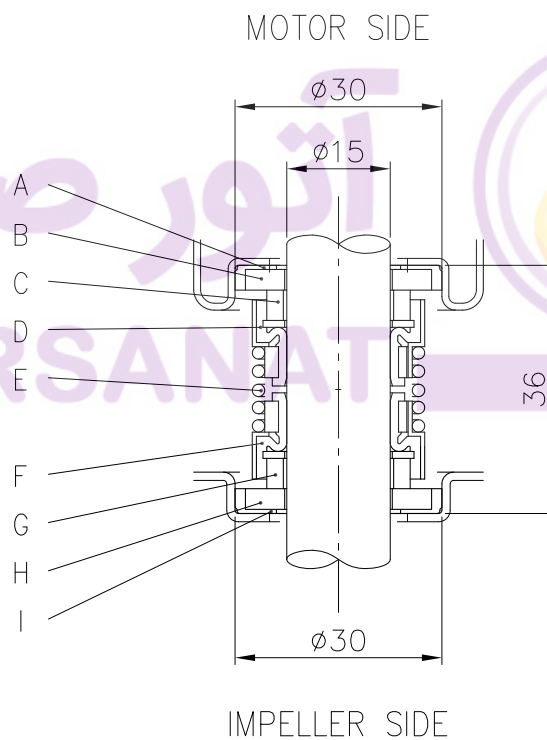

REF	PART NAME	MATERIAL
A	Rubber cup	NBR
B	Seat	Ceramic
C	Seal face	Carbon
D	Bellow	NBR
E	Spring	AISI 304
F	Bellow	NBR
G	Seal face	Silicon carbide
H	Seat	Silicon carbide
I	Rubber cup	NBR

**SUBMERSIBLE SEWAGE PUMPS**

**DIMENSIONS AND WEIGHT**

50Hz

Rev. H

**PUMP**

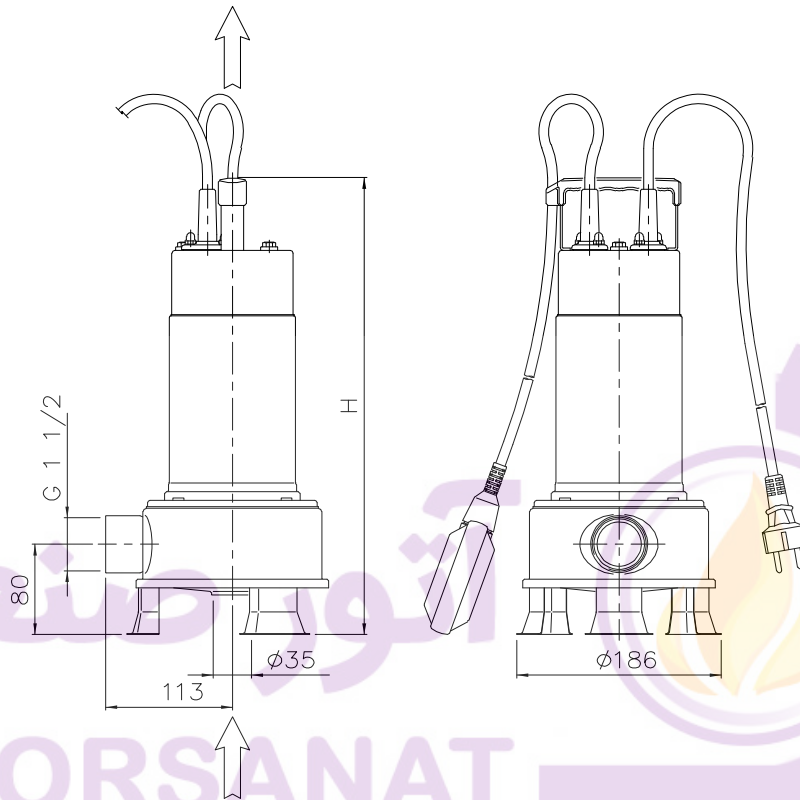

Type pumps		Dimension H [mm]	Weight [kg]	
Single Phase	Three Phase		Single Phase	Three Phase
RIGHT 75 M	RIGHT 75	405	10	10
RIGHT 100 M	RIGHT 100	430	11,5	11,5

**SUBMERSIBLE SEWAGE PUMPS**

**DIMENSIONS AND WEIGHT**

50Hz

Rev. H

**PACKING**

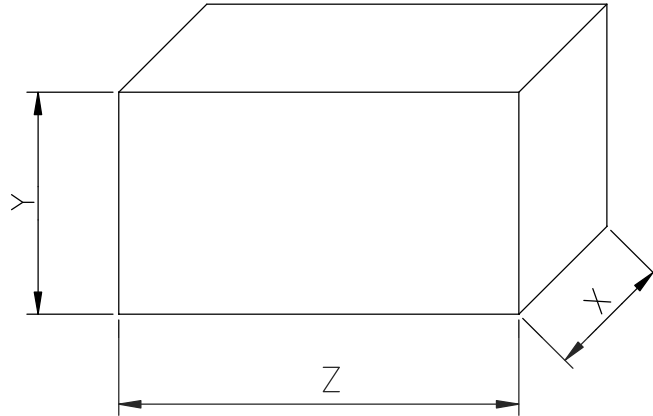

Type pumps		Packing [mm]			Weight [kg]	
Single Phase	Three Phase	Z	X	Y	Single Phase	Three Phase
RIGHT 75 M	RIGHT 75	450	195	245	10,7	10,7
RIGHT 100 M	RIGHT 100	450	195	245	12,2	12,2

آتور صنعت  
ATOORSANAT



## SUBMERSIBLE SEWAGE PUMPS

# RIGHT

### TECHNICAL DATA

50Hz

Rev. H

### MOTOR DATA

Pump Type		Power		Capacitor Single Phase		Input [kW]		Full load current [A]		Locked rotor current [A]	
Single Phase	Three Phase	[kW]	[HP]	[ $\mu$ F]	[Vc]	Single Phase	Three Phase	Single Phase	Three Phase	Single Phase	Three Phase
RIGHT 75 M	RIGHT 75	0,55	0,75	20	450	1,0	0,95	4,8	2,1	19,5	12
RIGHT 100 M	RIGHT 100	0,75	1	31,5	450	1,20	1,2	5,7	2,6	24,5	16

آتور صنعت  
ATOORSANAT



**SUBMERSIBLE SEWAGE PUMPS**

**INSTALLATION**

50Hz

Rev. H

**INSTALLATION**

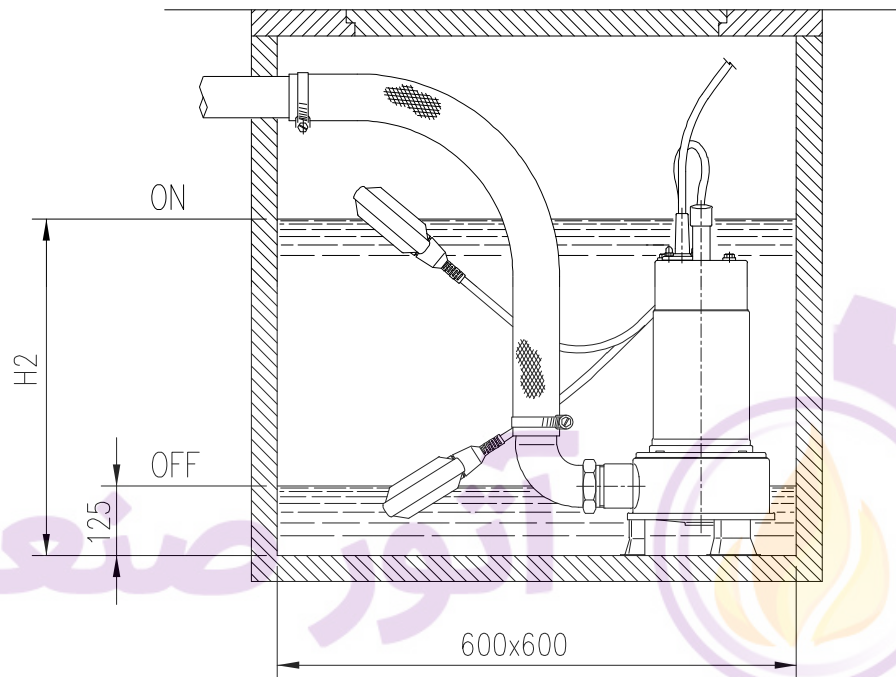

Pump type	Dimensions [mm]
	H2
RIGHT 75	410
RIGHT 100	430