

G 系列 G SERIES

气环式真空泵 / 压缩机

Side channel blower/compressor



浙江格凌实业有限公司
ZHEJIANG GREENCO INDUSTRY CO.,LTD

公司简介 Company Information

Zhejiang Greenco Industry Co., Ltd, established in 2001 and located in the famous "China Small Compressors Agglomeration City"--Zeguo Town, Wenling City, is one of China's high and new tech enterprises who is specialized in making air fluid equipments (compressors and vacuum pumps). With more than ten years' development, the company has become a professional manufacturer who is mainly committed to producing side channel blowers plus other kinds of air fluid equipments (vacuum pumps and compressors), forming the complete structure merging with R&D, production, sales and services. The Company has become the No.1 manufacturer in China and the leading manufacturer in the world in the industry of side channel blowers.

As of now, the Company with three factories and occupying more than 108,000 square meters, has powerful research and development techniques and advanced machining equipments---more than 300 production equipments, including 10 more die casting machines, 80 more advanced CNC machines which were directly imported from German and Japan, many kinds of high precision measurement instruments and devices, more than 70 testing equipments. The company always upholds the philosophy that it should have the integrated production and management, containing the whole process of design and development, tooling making, die casting, stamping, high precision machining, assembling and automatic spraying. What's more, the Company newly builds a modernized automatic-spraying and electro-coating production line for spare parts. By using this production line, every part should be electro-coated and thus the quality of our products are able to be controlled very well and improved increasingly.

The Company, the "Star Enterprise" in Zhejiang province, was rated as AA-rated "Zhejiang Enterprise of Keeping Contract and Value Credit" and "Zhejiang High and New tech Enterprise", "The Center of High and New tech Development of Taizhou", "Wenling Key Industrial Enterprise" and named as the pro-listed company. The company acquired the Certificate of ISO9001:2008 Quality System and the Certificate of ISO14001 Environment Management System. Ring blowers made in the Company are listed as Zhejiang key project of technical innovation by Zhejiang Economic and Trade Commission and have over 30 national invention and innovation patents. Leading the development of domestic air fluid equipments (compressors and vacuum pumps), the company has become the leader in this industry in China. Products in the Company rated as "Taizhou Famous Mark" and "Zhejiang Famous Brand" also acquired certificates like UL, CE, TUV, CCC, ROHS and are mainly exported to the developed countries in Europe and North America and are very popular among these customers.

With "Continuous Creation and Keeping Excelsior" set as Greenco's benchmark and adhering to the business principle of "Scientific Management, Brand Supremacy, Best Quality, Customer Satisfaction", we always believe that customers are the source of our continuous success. Warmly welcome friends home and abroad to visit and instruct in our company. Your arrivals are the power of our growth and we will give you surprises. We sincerely would like to work with you together to get the win-win achievements and create a glory future.

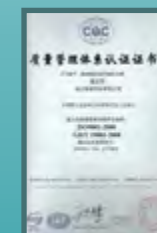
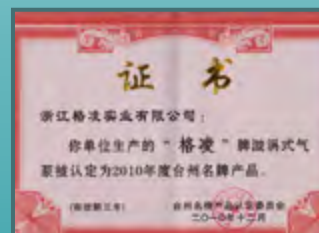

目录 Contents



G 系列产品总览 G Series overview	01-02
造型与订购信息 Selection and ordering information	
G_200 系列 G_200 series	03-46
G_400 系列 G_400 series	47-54
安装尺寸 Dimension	55-68
附录 Annex	69-72

آتور صنعت
ATOORSANAT

G_系列 气环式风机概述 G_series side channel blower



G_200
单级式风机
Single stage version



G_200
双极式风机可满足更高的要求
Two stage, For tougher requirements



G_400
高压单级式风机
Single stage For high pressure version



G_400
高压差多级式风机
Multi-stage reliability for high differential pressure

应用范围

- 气动运输系统
- 真空提升和夹持系统
- 包装机
- 污水厂通风单级式风机
- 袋装 / 瓶装 / 灌装系统
- 土壤改造
- 泡沫成型系统
- 信件的分类与包裹
- 食品处理系统
- 激光打印机
- 牙科真空抽吸机
- 纸张处理系统双级式风机
- 打印机 / 复印机可满足更高的要求
- 织补机
- 鱼池通风系统
- 气体分析
- 游泳池通风设备

Applications

- Pneumatic conveying systems
- Lifting and holding of parts by vacuum
- Packing machines
- Aeration of sewage-treatment plants
- Filling of bags/bottles/hoppers
- Soil remediation
- Thermoforming
- Sorting/enveloping of letters
- Food-processing
- Laser printers
- Dental suction equipments
- Paper processing
- Printers/copiers
- Textile machines
- Aeration of fish ponds
- Gas analysis
- Wsimming pool equipment/whirlpools

全球通用 永不落后

G 系列气环式风机以采用宽压双频。保护等级 IP55（绝缘等级 F）的电机为特色并且通过美国 UL、CE、CCC 认证。这使得它成为全球通用的最佳解决方案。它们不经过任何的改动和测试就可以在欧洲、美洲和亚洲使用，而且这些产品我们都备有库存，可以随时满足您的需求。

Ex stock for use world-wide

The G_series side channel blower feature voltage range motors for 50Hz and 60Hz in protection class IP55(insulation class F) are UL、CE、CCC approved.This makes them the ideal solution for world wide use.They can be used without any modifications or tests in Europe,America and Asia.They are mostly available ex stock.They are available for your requirements anytime.

G 系列气环泵工作原理

G 系列的叶轮直接安装在电机转子上，是完全地无接触压缩。由于泵轴承安装在压缩腔外，所以即便工作在最大的压差下，也能确保机器的最大工作可靠性。

气体由吸气口 1 吸入，当它进入侧通道 2 以后，旋转叶轮 3 在旋转方向上给气体一个速度，同时叶片上的离心力使气体向外加速并压力增加，随着旋转的进行，气体的动能增加，使得沿侧通道的气体压力进一步增加。随着侧通道在出口初变窄，气体被挤出叶片并通过出口消声器 4 排出泵体。

G_series operating principle

The impellers in the G_series machines are mounted directly on the motor shaft for noncontact compression entirely without friction.Maximum operational reliability,even at high differential pressures.is ensured by the arrangement of the bearings outside the compression chamber.

The gas is taken in through the inlet 1.As it enters the side channel 2,the rotating impeller 3 imparts velocity to the gas in the direction of rotation.Centrifugal force in the impeller blades accelerates the gas outward and the pressure increase.Every rotation adds kinetic energy,resulting in the further increase of the pressure along the side channel. The side channel narrows at the rotor,sweeping the gas off the impeller blades and discharging it through the outlet silencer 4 where it exits the side channel blower.

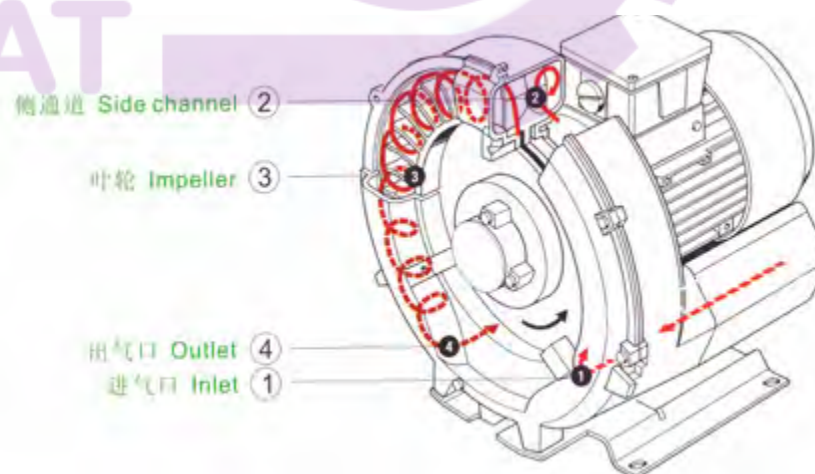

G-200 单级和双级 G-200 Single and double stage

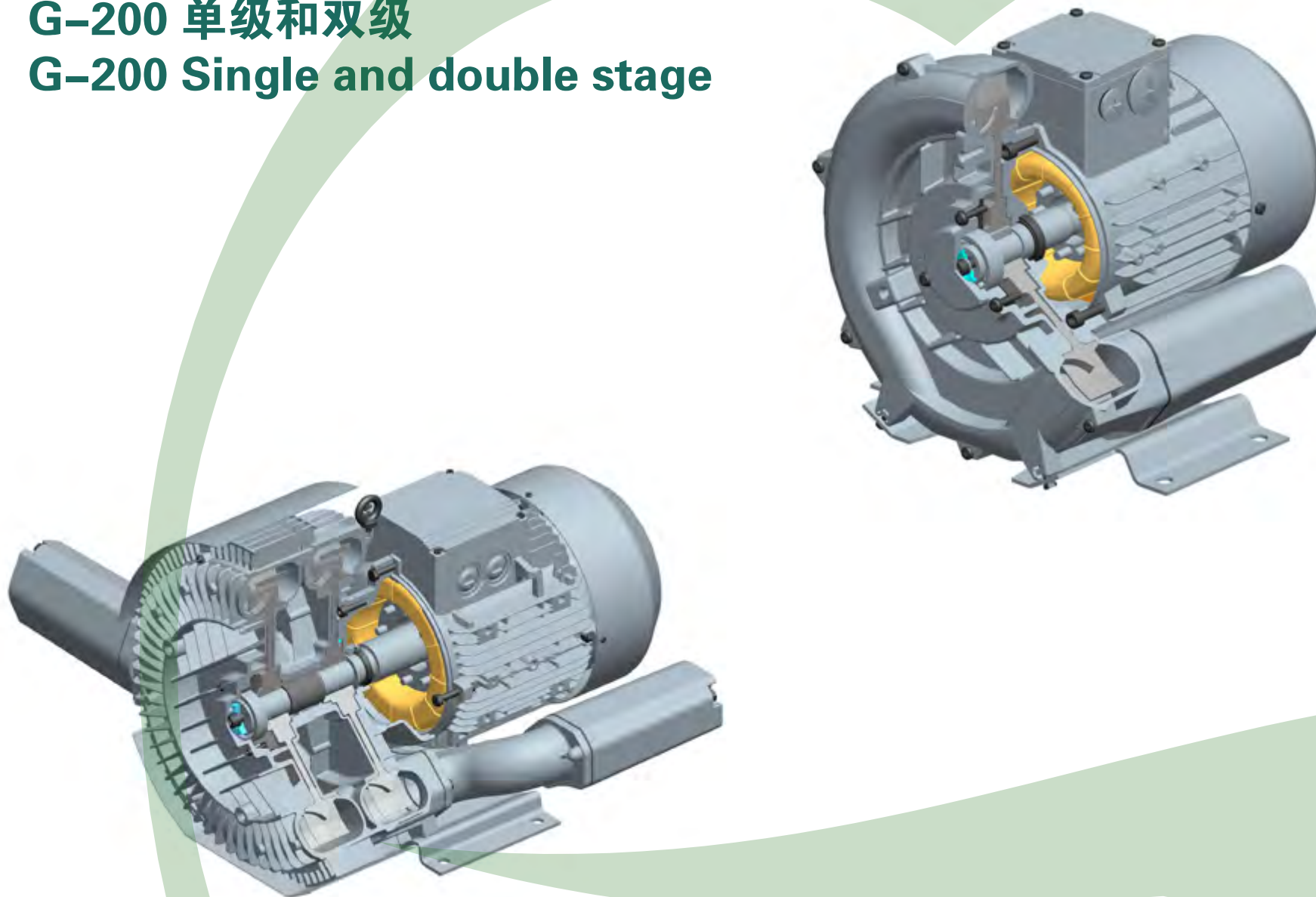

技术创新的经典之作 CLASSICS WITH INNOVATIVE TECHNOLOGY

拥有高达 2,500m³/h 吸气量和高达 780mbar 的压差，我们的 G_200 系列的各个产品都赢得了它们的声誉并且征服了全世界无数的用户。

在机械工程领域中，高可靠、低维护及长寿命已使它成为各个行业的首选。

当配以变频器后，G_200 气环泵 / 压缩机的性能还可大幅度地提高。

G_200 风机同样通过 UL/CCC/CE 认证，因此无需经过任何测试便能应用于世界各地。

G_200 选型图表

真空抽吸和压缩模式，50Hz/60Hz

第 05-46 页

有关电压、脚注等详细信息参看

第 72 页

With their high inlet volume flow up to 2,500m³/h and a differential pressure up to 780mbar, our low noise G_series allrounders have earned their reputation and convinced thousands of customers all over the world.

They are reliable, low-maintenance and durable and are the first choice for many applications in mechanical engineering.

When used with a frequency converter the performance of G_200 side channel blower can be increased considerably.

The G_200 series side channel blowers are UL/CCC/CE approved and can be used without further testing all over the world.

Selection diagrams and tables for G_200 series vacuum and pressure mode, 50Hz and 60Hz

Pages 05-46

Details on voltages, footnotes etc see.

Pages 72

2RB 1AC

G 系列 • G-Series

漩涡式气泵在真空和压力操作的选型和订购参数。单相电机

Selection and ordering data for side channel blowers in vacuum and pressure operation.single-phase current

订购型号	马达			重量	噪音	最大流量	最高真空	最高压力	真空阀	
	• 有库存	额定							类型 × 型号	
		输出功率	电压	电流						
Order No.		MOTOR			weight	Sound-	Maximum airflow	Maximum vacuum	Maximum pressure	Vacuum relet
• available ex stock	Fre- quency	Rated		approx	pressure	level				valve
		output	voltage	current					Item × type	
	HZ	KW	V	A	KG	dB(A)	m³/h	mbar	mbar	
• 2RB 210-7AA11	50	0.37	230	2.7	11	53	80	-110	110	1×12B×12110/...2141
	60	0.45	230	3.0		56	96	-130	140	1×12B×12114/...2142
• 2RB 230-7AA11	50	0.37	230	2.7	11	54	100	-110	110	1×12B×12110/...2141
	60	0.45	230	3.0		57	120	-130	140	1×12B×12114/...2142
• 2RB 310-7AA01	50	0.55	230	3.7	13	55	100	-120	120	1×12B×12114/...2142
	60	0.62	230	4.5		57	120	-130	150	1×12B×12114/...2142
• 2RB 310-7AA11	50	0.7	230	4.8	14	55	100	-150	150	1×12B×12114/...2142
	60	0.8	230	4.1		57	120	-150	160	1×12B×12114/...2142
• 2RB 320-7HA31	50	1.1	230	7.3	17	58	120	-240	280	1×12B×12110/...2141
	60	1.3	230	8.3		60	145	-230	260	1×12B×12114/...2142
• 2RB 330-7AA11	50	0.7	230	4.8	14	56	145	-100	100	1×12B×12110/...2141
	60	0.8	230	4.1		58	165	-110	100	1×12B×12114/...2142
• 2RB 410-7AA11	50	0.8	230	5.2	15	63	145	-150	160	1×12B×12110/...2141
	60	0.9	230	5.8		64	175	-160	140	1×12B×12114/...2142
• 2RB 410-7AA21	50	1.1	230	7.3	16	63	145	-150	190	1×12B×12110/...2141
	60	1.3	230	8.3		64	175	-180	190	1×12B×12114/...2142
• 2RB 420-7HA31	50	1.5	230	9	26	66	150	-280	290	1×12B×12110/...2141
	60	1.75	230	10		69	180	-250	280	1×12B×12114/...2142
• 2RB 430-7AA11	50	0.8	230	5.2	16	64	180	-100	110	1×12B×12110/...2141
	60	0.9	230	5.8		66	210	-100	110	1×12B×12110/...2141
• 2RB 430-7AA21	50	1.1	230	7.3	17	64	180	-150	140	1×12B×12110/...2141
	60	1.3	230	8.3		66	210	-140	130	1×12B×12114/...2142
• 2RB 510-7AA11	50	1.1	230	7.3	21	64	210	-160	160	1×1B×12110/...2145
	60	1.3	230	8.3		70	255	-150	160	1×12B×12110/...2146
• 2RB 510-7AA21	50	1.5	230	10.4	24	64	210	-190	200	1×12B×12110/...2145
	60	1.75	230	11.2		70	255	-180	180	1×12B×12110/...2146
• 2RB 530-7AA21	50	1.5	230	10.4	26	65	270	-150	140	1×12B×12110/...2145
	60	1.75	230	11.2		71	330	-120	110	1×12B×12110/...2146
• 2RB 710-7AA11	50	2.2	230	12.8	30	72	318	-190	190	1×12B×12110/...2141
	60	2.55	230	12.8		74	376	-190	200	1×12B×12114/...2146

2RB Series Selection diagram 50/60Hz 1AC

2RB 系列 50/60Hz 选型图表 1AC



下面的性能曲线是在抽吸 15°C 空气，排气压力 1013mbar 的工况下测出的，允差 ±10%，吸入空气和环境温度不超过 25°C 时，即可达到图示总压差。

The performance curves are valid for pumping air at 15°C at the inlet flanges with an air pressure of 1.013mbar and a tolerance of ± 10%. The total pressure differences are valid up to an intake and ambient temperature of 25°C .

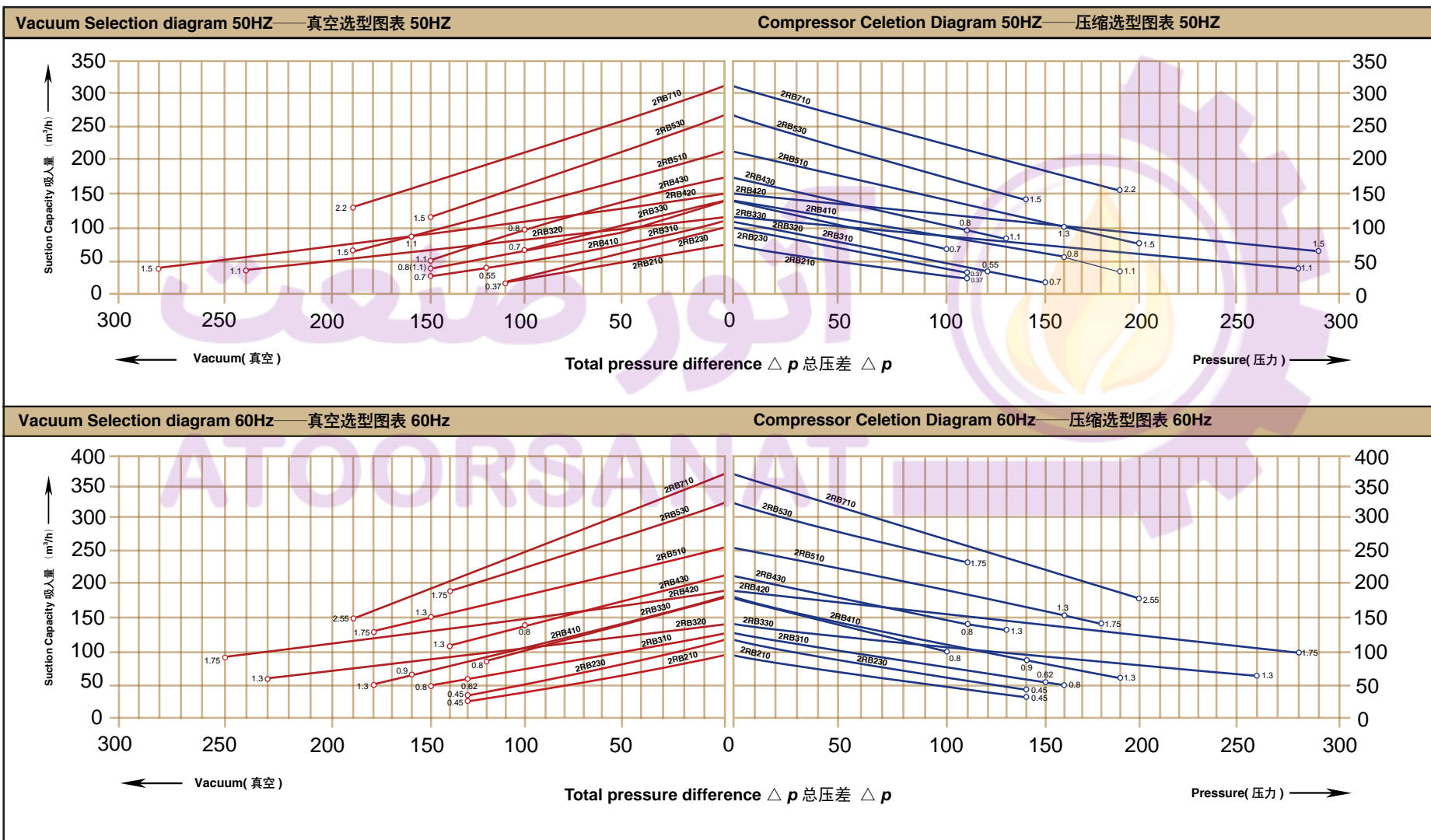



2RB 1AC

G 系列 · G-Series

漩涡式气泵在真空和压力操作的选型和订购参数。单相电机

Selection and ordering data for side channel blowers in vacuum and pressure operation. single-phase current

订购型号	马 达				重量	噪音	最大流量	最高真空	最高压力	真空阀
	· 有库存	额定								类型 × 型号
		输出功率	电压	电流						
Order No.	MOTOR				Weight approx	Sound-Pressure level	Maximum airflow	Maximum vacuum	Maximum pressure	Vacuum relief valve
· available ex stock	Fre-quency	Rated								Items × type
		output	voltage	current						
	HZ	KW	V	A	KG	DB(A)	m³/h	mbar	mbar	
2RB 210-7AV15	50	0.37	115/230	5.4/2.7	11	53	80	-110	110	1xBx110...2141
	60	0.45	115/230	6.0/3.0		56	96	-130	140	1xBx114...2142
2RB 230-7AV15	50	0.37	115/230	5.4/2.7	11	54	101	-110	110	1xBx110...2141
	60	0.45	115/230	6.0/3.0		57	121	-130	140	1xBx114...2142
2RB 410-7AV25	50	1.1	115/230	14.6/7.3	16	63	148	-180	190	1xBx110...2141
	60	1.3	115/230	16.6/8.3		64	190	-180	190	1xBx114...2142
2RB 420-7AV45	50	1.5	115/230	22/11	27	66	150	-250	260	1xBx110...2141
	60	1.75	115/230	24/12		69	190	-250	270	1xBx114...2142
2RB 430-7AV25	50	1.1	115/230	14.6/7.3	16	64	180	-170	170	1xBx110...2141
	60	1.3	115/230	16.6/8.3		65	212	-180	180	1xBx110...2141
2RB 490-7AV45	50	1.1	115/230	14.6/7.3	17	63	142	-110	120	1xBx110...2141
	60	1.3	115/230	16.6/8.3		64	172	-140	140	1xBx110...2142
2RB 510-7AV35	50	1.5	115/230	22/11	26	64	210	-190	200	1xBx114...2145
	60	1.75	115/230	24/12		70	255	-180	180	1xBx110...2146
2RB 530-7AV35	50	1.5	115/230	22/11	26	65	270	-150	140	1xBx110...2141
	60	1.75	115/230	24/12		71	325	-120	110	1xBx114...2146

2RB Series Selection diagram 50/60Hz 1AC

2RB 系列 50/60Hz 选型图表 1AC



下面的性能曲线是在抽吸 15°C 空气，排气压力 1013mbar 的工况下测出的，允差 ±10%，吸入空气和环境温度不超过 25°C 时，即可达到图示总压差。

The performance curves are valid for pumping air at 15°C at the inlet flanges with an air pressure of 1.013mbar and a tolerance of ±10%. The total pressure differences are valid up to an intake and ambient temperature of 25°C.

G-200

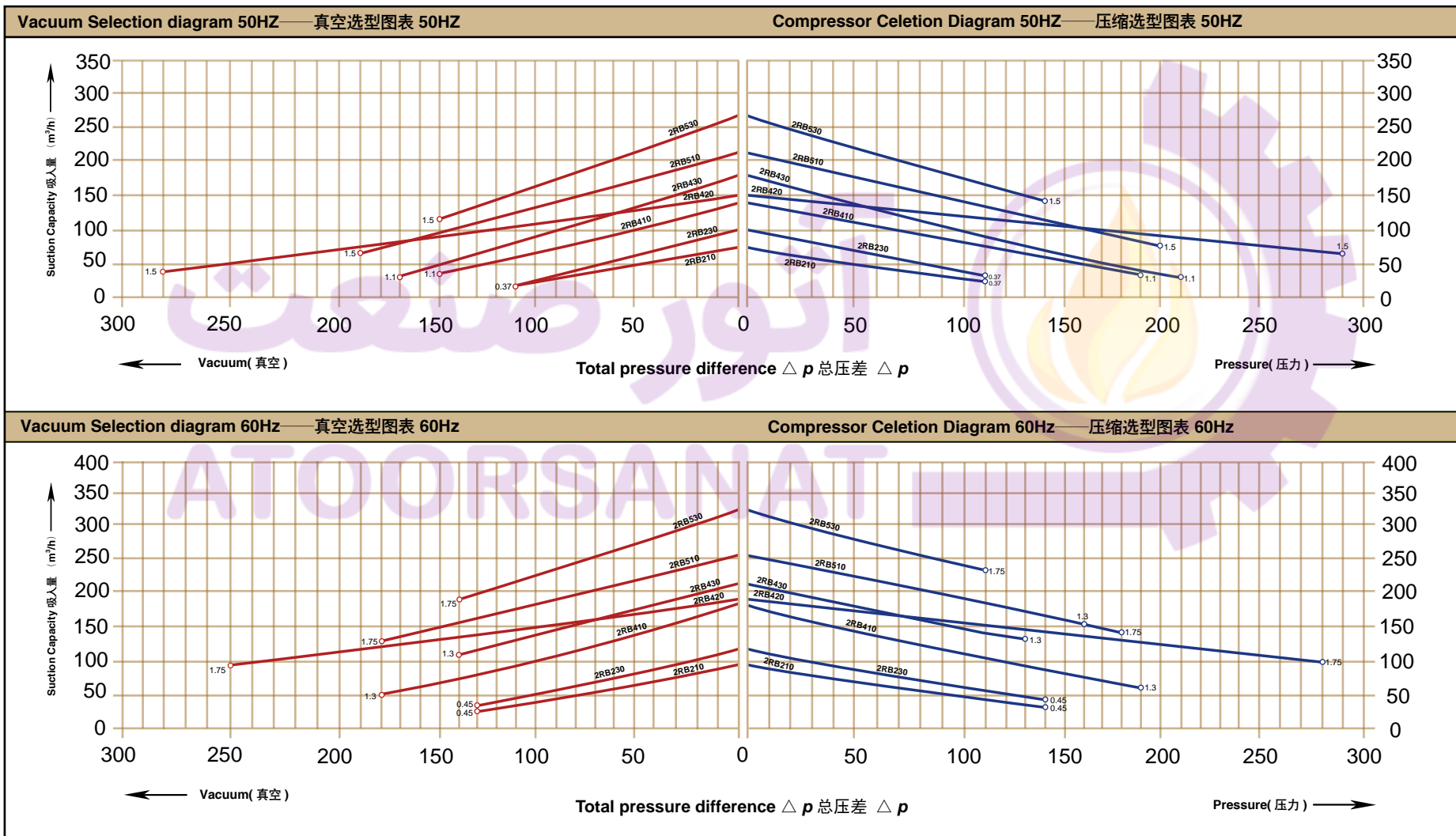

2RB2 3AC

G 系列 · G-Series

漩涡式气泵在真空和压力操作的选型和订购参数。

Selection and ordering data for side channel blowers in vacuum and pressure operation.

订购型号	马 达				重量	噪音	最大流量	最高真空	最高压力	真空阀
· 有库存	额定			输出功率						电压
Order No.	MOTOR				Weight approx	Sound-Pressure level	Maximum airflow	Maximum vacuum	Maximum pressure	
· available ex stock	Fre-quency	Rated								output
		HZ	KW	V	A	KG	DB(A)	m³/h	mbar	
· 2RB 210-7AH06	50	0.25	200-240 △ /345-415	2.1 △ /1.2Y	9	53	80	-100	110	1x...2110/...2141
	60	0.29	220-275 △ /380-480	2.0 △ /1.15Y		56	98	-110	110	1x...2114/...2142
· 2RB 210-7AH16	50	0.4	200-240 △ /345-415	2.6 △ /1.5Y	10	53	80	-120	130	1x...2110/...2141
	60	0.5	220-275 △ /380-480	2.6 △ /1.5Y		56	98	-150	160	1x...2114/...2142
· 2RB 220-7AH26	50	0.7	200-240 △ /345-415	3.8 △ /2.2Y	15	55	85	-210	240	1x...2110/...2141
	60	0.83	220-275 △ /380-480	3.75 △ /2.15Y		61	102	-250	250	1x...2114/...2142
· 2RB 230-7AH06	50	0.25	200-240 △ /345-415	2.1 △ /1.2Y	10	54	105	-80	70	1x...2110/...2141
	60	0.29	220-275 △ /380-480	1.7 △ /1.0Y		57	120	-90	80	1x...2114/...2142
· 2RB 230-7AH16	50	0.4	200-240 △ /345-415	2.6 △ /1.5Y	11	54	105	-120	130	1x...2110/...2141
	60	0.5	220-275 △ /380-480	2.6 △ /1.5Y		57	120	-150	160	1x...2114/...2142
· 2RB 230-7AH26	50	0.7	200-240 △ /345-415	3.8 △ /2.2Y	12	54	105	-120	140	1x2Bx2110/...2141
	60	0.83	220-275 △ /380-480	3.8 △ /2.2Y		57	120	-160	180	1x2Bx2114/...2142

2RB2 Series Selection diagram 50/60Hz 3AC

2RB2 系列 50/60Hz 选型图表 3AC



下面的性能曲线是在抽吸 15°C 空气，排气压力 1013mbar 的工况下测出的，允差 ±10%，吸入空气和环境温度不超过 25°C 时，即可达到图示总压差。

The performance curves are valid for pumping air at 15°C at the inlet flanges with an air pressure of 1.013mbar and a tolerance of ±10%. The total pressure differences are valid up to an intake and ambient temperature of 25°C .

G-200

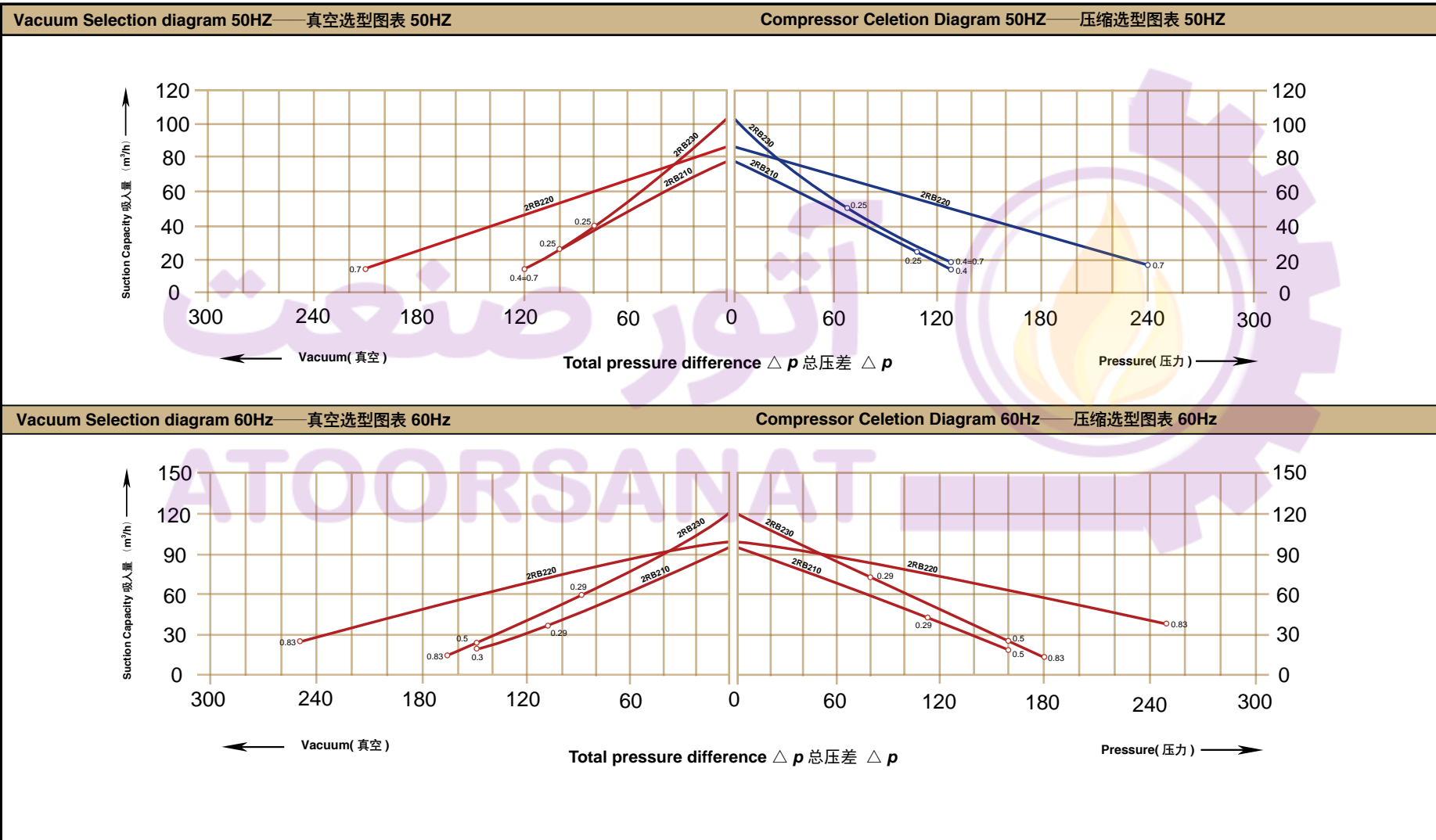

2RB3 3AC

G 系列 · G-Series

漩涡式气泵在真空和压力操作的选型和订购参数。

Selection and ordering data for side channel blowers in vacuum and pressure operation.

订购型号	马 达				重量	噪音	最大流量	最高真空	最高压力	真空阀
· 有库存	额 定			类型 × 型号						
	输出功率	电 压	电 流							
Order No.	MOTOR				Weight approx	Sound-Pressure level	Maximum airflow	Maximum vacuum	Maximum pressure	Vacuum relief valve
· available ex stock	Fre-quency	Rated								Items × type
		output	voltage	current						
	HZ	KW	V	A	KG	dB(A)	m³/h	mbar	mbar	
· 2RB 310-7AH06	50	0.55	200-240 △ /345-415	2.8 △ /1.6Y	11	55	100	-110	120	1x2Bx2110/...2141
	60	0.63	220-275 △ /380-480	3.0 △ /1.7Y		57	120	-110	120	1x2Bx2114/...2142
· 2RB 310-7AH16	50	0.7	200-240 △ /345-415	3.8 △ /2.2Y	12	55	100	-150	150	1x2Bx2110/...2141
	60	0.83	220-275 △ /380-480	3.8 △ /2.2Y		57	120	-150	140	1x2Bx2114/...2142
· 2RB 320-7HH26	50	0.85	200-240 △ /345-415	4.2 △ /2.4Y	17	58	110	-200	230	1x2Bx2110/...2141
	60	0.95	220-275 △ /380-480	4.0 △ /2.3Y		60	130	-240	240	1x2Bx2114/...2142
· 2RB 320-7HH36	50	1.3	200-240 △ /345-415	5.7 △ /3.3Y	18	58	110	-280	290	1x2Bx2110/...2141
	60	1.5	220-275 △ /380-480	6.0 △ /3.5Y		60	130	-300	400	1x2Bx2114/...2142
· 2RB 330-7AH06	50	0.55	200-240 △ /345-415	2.8 △ /1.6Y	12	56	140	-60	60	1x2Bx2110/...2141
	60	0.63	220-275 △ /380-480	3.0 △ /1.7Y		58	165	-50	50	1x2Bx2114/...2142
· 2RB 330-7AH16	50	0.7	200-240 △ /345-415	3.8 △ /2.2Y	13	56	140	-100	100	1x2Bx2110/...2141
	60	0.83	220-275 △ /380-480	3.8 △ /2.2Y		58	165	-115	100	1x2Bx2114/...2142

2RB3 Series Selection diagram 50/60Hz 3AC

2RB3 系列 50/60Hz 选型图表 3AC



下面的性能曲线是在抽吸 15°C 空气，排气压力 1013mbar 的工况下测出的，允差 ±10%，吸入空气和环境温度不超过 25°C 时，即可达到图示总压差。

The performance curves are valid for pumping air at 15°C at the inlet flanges with an air pressure of 1.013mbar and a tolerance of ±10%.The total pressure differences are valid up to an intake and ambient temperature of 25°C .

G-200

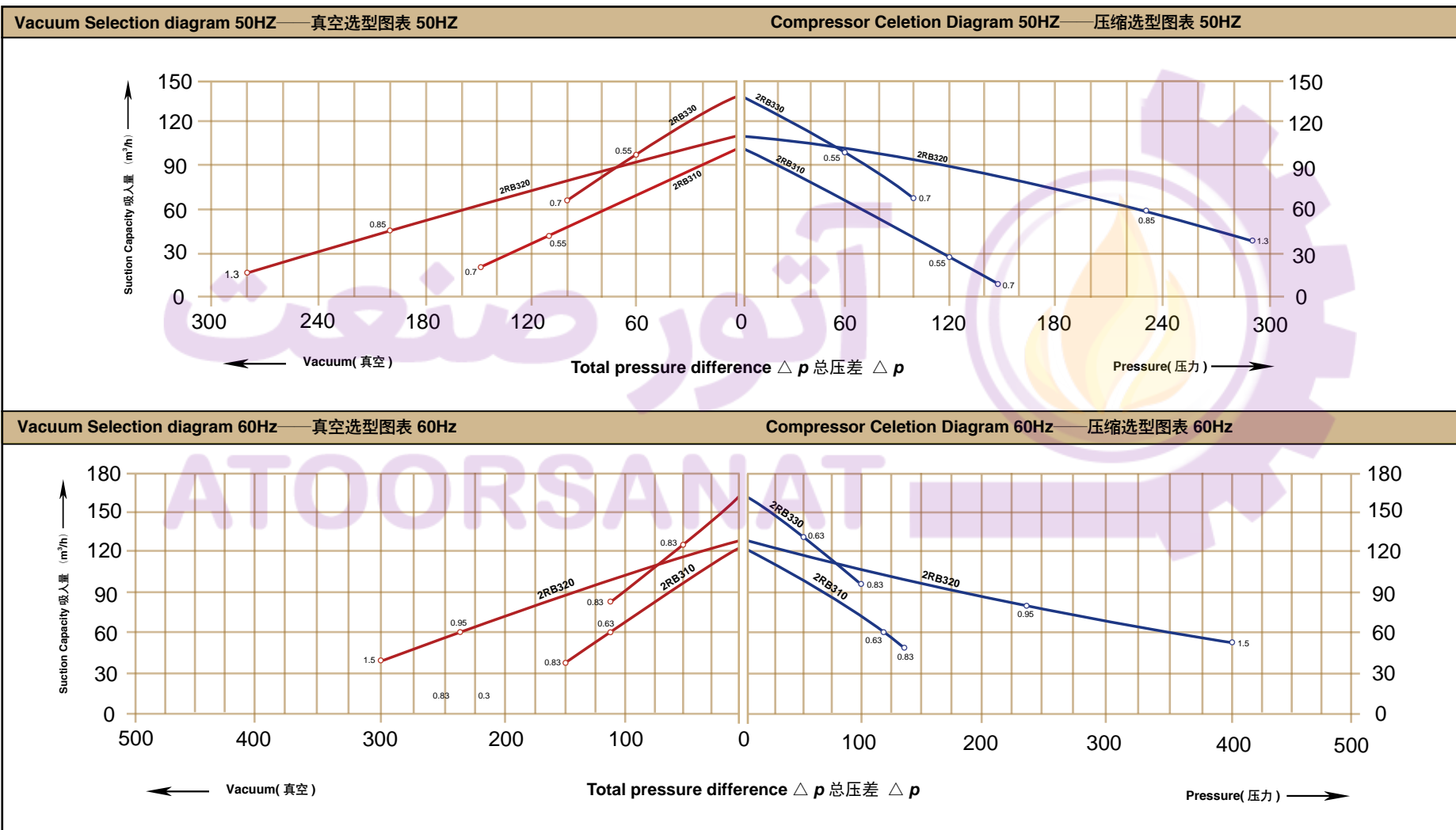

2RB4 3AC

G 系列 · G-Series

漩涡式气泵在真空和压力操作的选型和订购参数。

Selection and ordering data for side channel blowers in vacuum and pressure operation.

订购型号	马 达				重量	噪音	最大流量	最高真空	最高压力	真空阀
· 有库存	额 定			输出 功率						电 压
Order No.	MOTOR				Weight approx	Sound- Pressure level	Maximum airflow	Maximum vacuum	Maximum pressure	
· available ex stock	Fre-quency	Rated								output
	HZ	KW	V	A	KG	dB(A)	m³/h	mbar	mbar	
· 2RB 410-7AH06	50	0.7	200-240 △ /345-415	3.8 △ /2.2Y	13	63	145	-120	120	1x...2110/...2141
	60	0.83	220-275 △ /380-480	3.75 △ /2.15Y		64	175	-140	140	1x...2114/...2142
· 2RB 410-7AH16	50	0.85	200-240 △ /345-415	4.0 △ /2.3Y	16	63	145	-160	160	1x...2110/...2141
	60	0.95	220-275 △ /380-480	3.85 △ /2.25Y		64	175	-160	160	1x...2114/...2142
· 2RB 410-7AH26	50	1.3	200-240 △ /345-415	5.7 △ /3.3Y	17	63	145	-170	200	1x...2110/...2141
	60	1.5	220-275 △ /380-480	6.0 △ /3.5Y		64	175	-210	220	1x...2114/...2142
· 2RB 420-7HH36	50	1.6	200-240 △ /345-415	7.5 △ /4.3Y	25	66	150	-280	280	1x2Bx2110/...2141
	60	2.05	220-275 △ /380-480	7.6 △ /4.4Y		69	180	-320	310	2x2Bx2114/...2142
· 2RB 420-7HH46	50	2.2	200-240 △ /345-415	9.7 △ /5.6Y	27	66	150	-330	420	1x2Bx2110/...2141
	60	2.55	220-275 △ /380-480	10.0 △ /5.8Y		69	180	-350	440	1x2Bx2114/...2142
· 2RB 430-7AH06	50	0.7	200-240 △ /345-415	3.8 △ /2.2Y	14	64	180	-70	70	1x...2110/...2141
	60	0.83	220-275 △ /380-480	3.8 △ /2.2Y		65	210	-50	50	2x...2114/...2142
· 2RB 430-7AH16	50	0.85	200-240 △ /345-415	4.2 △ /2.4Y	17	64	180	-110	100	1x...2110/...2141
	60	0.95	220-275 △ /380-480	4.0 △ /2.3Y		65	210	-90	70	2x...2114/...2142
· 2RB 430-7AH26	50	1.3	200-240 △ /345-415	6.6 △ /3.8Y	18	64	180	-180	180	1x...2110/...2141
	60	1.5	220-275 △ /380-480	6.9 △ /4.0Y		65	210	-180	170	1x...2114/...2142
· 2RB 490-7AH16	50	0.55	200-240 △ /345-415	2.5 △ /1.4Y	14	63	140	-120	120	—
	60	0.75	220-275 △ /380-480	2.7 △ /1.6Y		64	175	-140	140	—

2RB4 Series Selection diagram 50/60Hz 3AC

2RB4 系列 50/60Hz 选型图表 3AC



下面的性能曲线是在抽吸 15°C 空气，排气压力 1013mbar 的工况下测出的，允差 ±10%，吸入空气和环境温度不超过 25°C 时，即可达到图示总压差。

The performance curves are valid for pumping air at 15°C at the inlet flanges with an air pressure of 1.013mbar and a tolerance of ±10%. The total pressure differences are valid up to an intake and ambient temperature of 25°C .

G-200

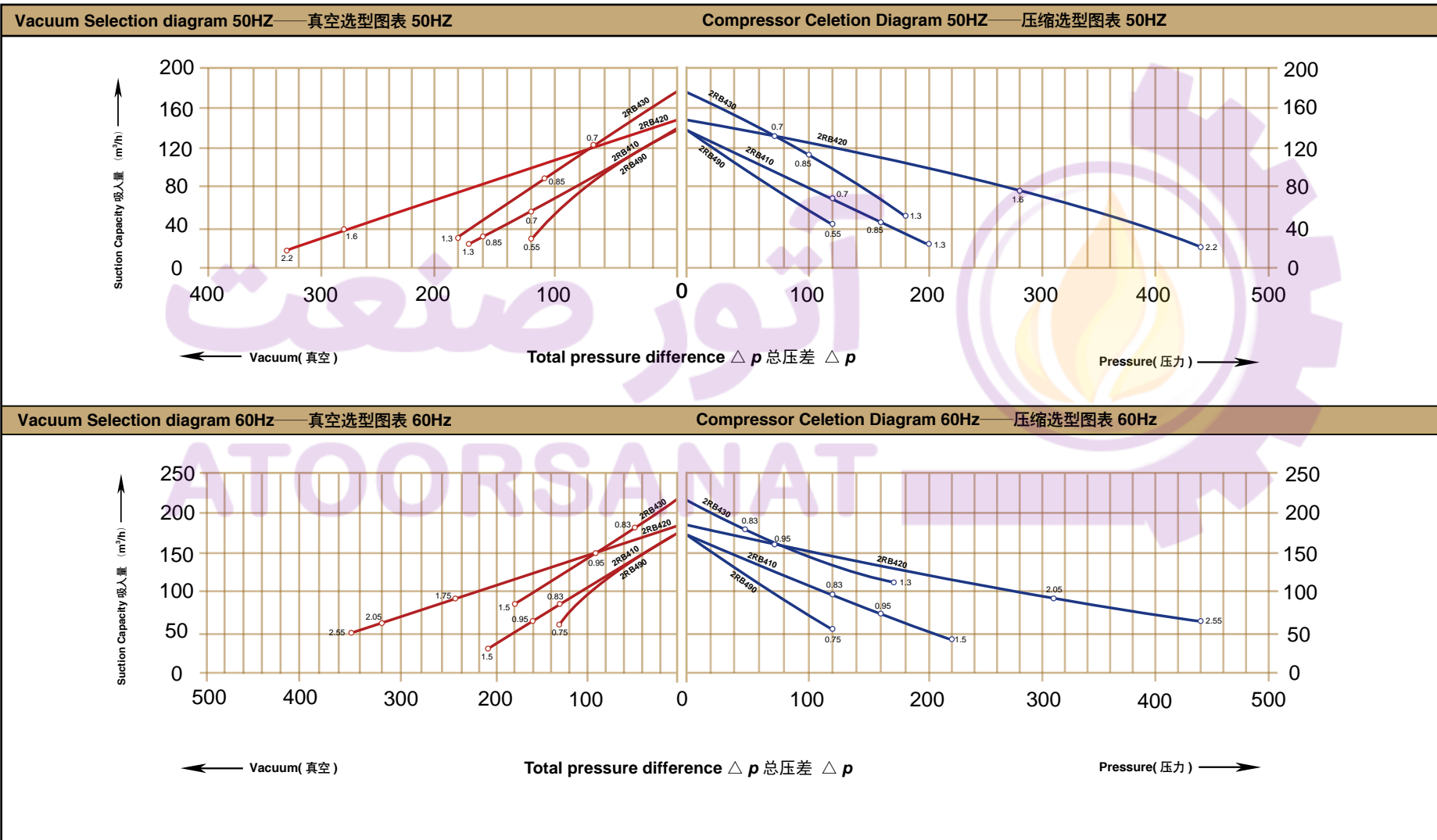

2RB5 3AC

G 系列 · G-Series

漩涡式气泵在真空和压力操作的选型和订购参数。

Selection and ordering data for side channel blowers in vacuum and pressure operation.

订购型号	马 达				重量	噪音	最大流量	最高真空	最高压力	真空阀
· 有库存	额 定			类型 × 型号						
	输出功率	电 压	电 流							
Order No.	MOTOR				Weight approx	Sound-Pressure level	Maximum airflow	Maximum vacuum	Maximum pressure	Vacuum relief valve
· available ex stock	Fre-quency	Rated								Items × type
	output	voltage	current							
	HZ	KW	V	A	KG	dB(A)	m³/h	mbar	mbar	
· 2RB 510-7AH06	50	0.85	200-240 △ /345-415	4.0 △ /2.3Y	20	64	210	-110	100	1x...2110/...2145
	60	0.95	220-275 △ /380-480	4.2 △ /2.3Y		70	255	-80	70	1x...2114/...2146
· 2RB 510-7AH16	50	1.3	200-240 △ /345-415	6.6 △ /3.8Y	22	64	210	-170	170	1x...2110/...2145
	60	1.5	220-275 △ /380-480	6.9 △ /4.0Y		70	255	-150	140	1x...2114/...2146
· 2RB 510-7AH26	50	1.6	200-240 △ /345-415	7.5 △ /4.3Y	23	64	210	-200	190	1x...2110/...2145
	60	2.05	220-275 △ /380-480	7.6 △ /4.4Y		70	255	-220	210	1x...2114/...2146
· 2RB 510-7AH36	50	2.2	200-240 △ /345-415	9.7 △ /5.6Y	25	64	210	-220	270	1x...2110/...2145
	60	2.55	220-275 △ /380-480	10.3 △ /6.0Y		70	255	-260	290	1x...2114/...2146
· 2RB 520-7HH46	50	3.0	200-240 △ /345-415	12.5 △ /7.2Y	40	72	230	-340	410	1x2B2110/...2145
	60	3.45	220-275 △ /380-480	12.6 △ /7.3Y		74	275	-380	360	1x2B2114/...2146
· 2RB 520-7HH57	50	4.0	345-415 △ /600-720	10.0 △ /5.8Y	41	72	230	-390	440	1x2B2110/...2145
	60	4.6	380-480 △ /660-720	9.9 △ /5.71Y		74	275	-410	480	1x2B2114/...2146
· 2RB 530-7AH06	50	0.85	200-240 △ /345-415	4.0 △ /2.3Y	21	65	270	-40	40	1x...2110/...2145
	60	0.95	220-275 △ /380-480	4.2 △ /2.4Y		71	330	-40	40	1x...2114/...2146
· 2RB 530-7AH16	50	1.3	200-240 △ /345-415	6.6 △ /3.8Y	23	65	270	-120	110	1x...2110/...2145
	60	1.5	220-275 △ /380-480	6.9 △ /4.0Y		71	330	-90	80	1x...2114/...2146
· 2RB 530-7AH26	50	1.6	200-240 △ /345-415	7.5 △ /4.3Y	24	65	270	-160	150	1x...2110/...2145
	60	2.05	220-275 △ /380-480	7.6 △ /4.4Y		71	330	-160	150	1x...2114/...2146
· 2RB 530-7AH36	50	2.2	200-240 △ /345-415	9.7 △ /5.6Y	26	65	270	-220	230	1x...2110/...2145
	60	2.55	220-275 △ /380-480	10.3 △ /6.0Y		71	330	-260	250	1x...2110/...2146
· 2RB 590-7AH26	50	1.1	200-240 △ /345-415	5.7 △ /3.3Y	23	64	210	-130	150	—
	60	1.7	220-275 △ /380-480	6.0 △ /3.5Y		71	255	-180	210	—

2RB5 Series Selection diagram 50/60Hz 3AC

2RB5 系列 50/60Hz 选型图表 3AC



下面的性能曲线是在抽吸 15°C 空气，排气压力 1013mbar 的工况下测出的，允差 ±10%，吸入空气和环境温度不超过 25°C 时，即可达到图示总压差。

The performance curves are valid for pumping air at 15°C at the inlet flanges with an air pressure of 1.013mbar and a tolerance of ±10%. The total pressure differences are valid up to an intake and ambient temperature of 25°C .

G-200

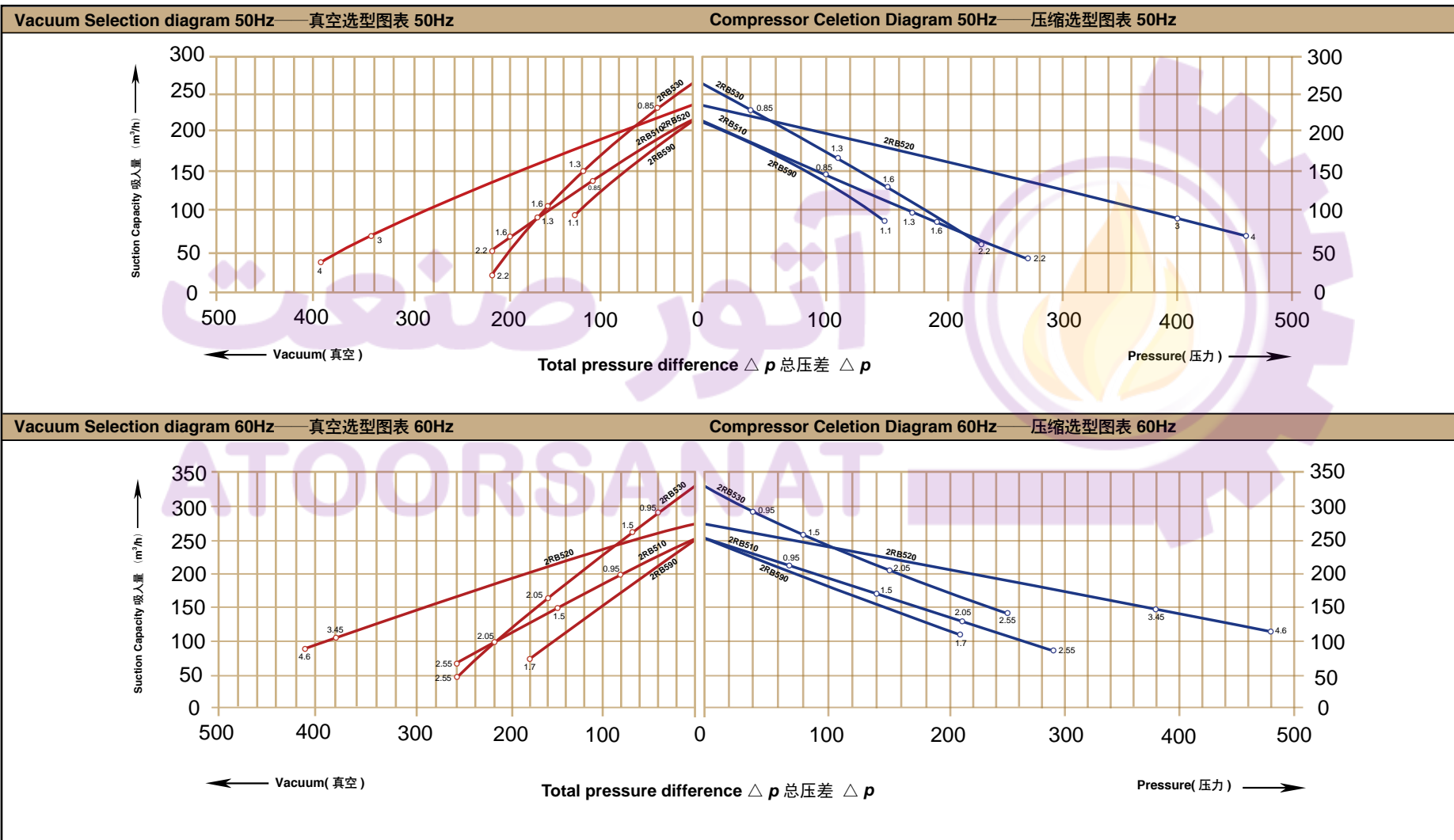

2RB6 3AC

G 系列 · G-Series

漩涡式气泵在真空和压力操作的选型和订购参数。

Selection and ordering data for side channel blowers in vacuum and pressure operation.

订购型号	马 达				重量	噪音	最大流量	最高真空	最高压力	真空阀
· 有库存	额 定			类型 × 型号						
	输出功率	电 压	电 流							
Order No.	MOTOR				Weight approx	Sound-Pressure level	Maximum airflow	Maximum vacuum	Maximum pressure	Vacuum relief valve
· available ex stock	Fre-quency	Rated								Items × type
		output	voltage	current						
	HZ	KW	V	A	KG	dB(A)	m³/h	mbar	mbar	
· 2RB 610-7AH06	50	1.6	200-240 △ /345-415	8.5 △ /4.9Y	25	68	265	-170	180	1x...2110/...2145
	60	2.05	220-275 △ /380-480	8.8 △ /5.1Y		70	315	-180	190	1x...2114/...2146
· 2RB 610-7AH16	50	2.2	200-240 △ /345-415	9.7 △ /5.6Y	28	69	265	-235	220	1x...2110/...2145
	60	2.55	220-275 △ /380-480	10.3 △ /6.0Y		72	315	-245	230	1x...2114/...2146
· 2RB 610-7AH26	50	3.0	200-240 △ /345-415	12.5 △ /7.2Y	34	69	265	-280	280	1x...2110/...2145
	60	3.45	220-275 △ /380-480	12.6 △ /7.3Y		72	315	-260	270	1x...2114/...2146
· 2RB 630-7AH06	50	1.6	200-240 △ /345-415	8.5 △ /4.9Y	26	70	345	-125	125	1x...2110/...2145
	60	2.05	220-275 △ /380-480	8.8 △ /5.1Y		73	415	-105	130	1x...2114/...2146
· 2RB 630-7AH16	50	2.2	200-240 △ /345-415	9.7 △ /5.6Y	29	70	345	-200	195	1x...2110/...2145
	60	2.55	220-275 △ /380-480	10.3 △ /6.0Y		73	415	-170	195	1x...2114/...2146
· 2RB 630-7AH26	50	3.0	200-240 △ /345-415	12.5 △ /7.2Y	35	70	345	-240	220	1x...2110/...2145
	60	3.45	220-275 △ /380-480	12.6 △ /7.3Y		73	415	-210	220	1x...2114/...2146

2RB6 Series Selection diagram 50/60Hz 3AC

2RB6 系列 50/60Hz 选型图表 3AC



下面的性能曲线是在抽吸 15°C 空气，排气压力 1013mbar 的工况下测出的，允差 ±10%，吸入空气和环境温度不超过 25°C 时，即可达到图示总压差。

The performance curves are valid for pumping air at 15°C at the inlet flanges with an air pressure of 1.013mbar and a tolerance of ±10%. The total pressure differences are valid up to an intake and ambient temperature of 25°C.

G-200

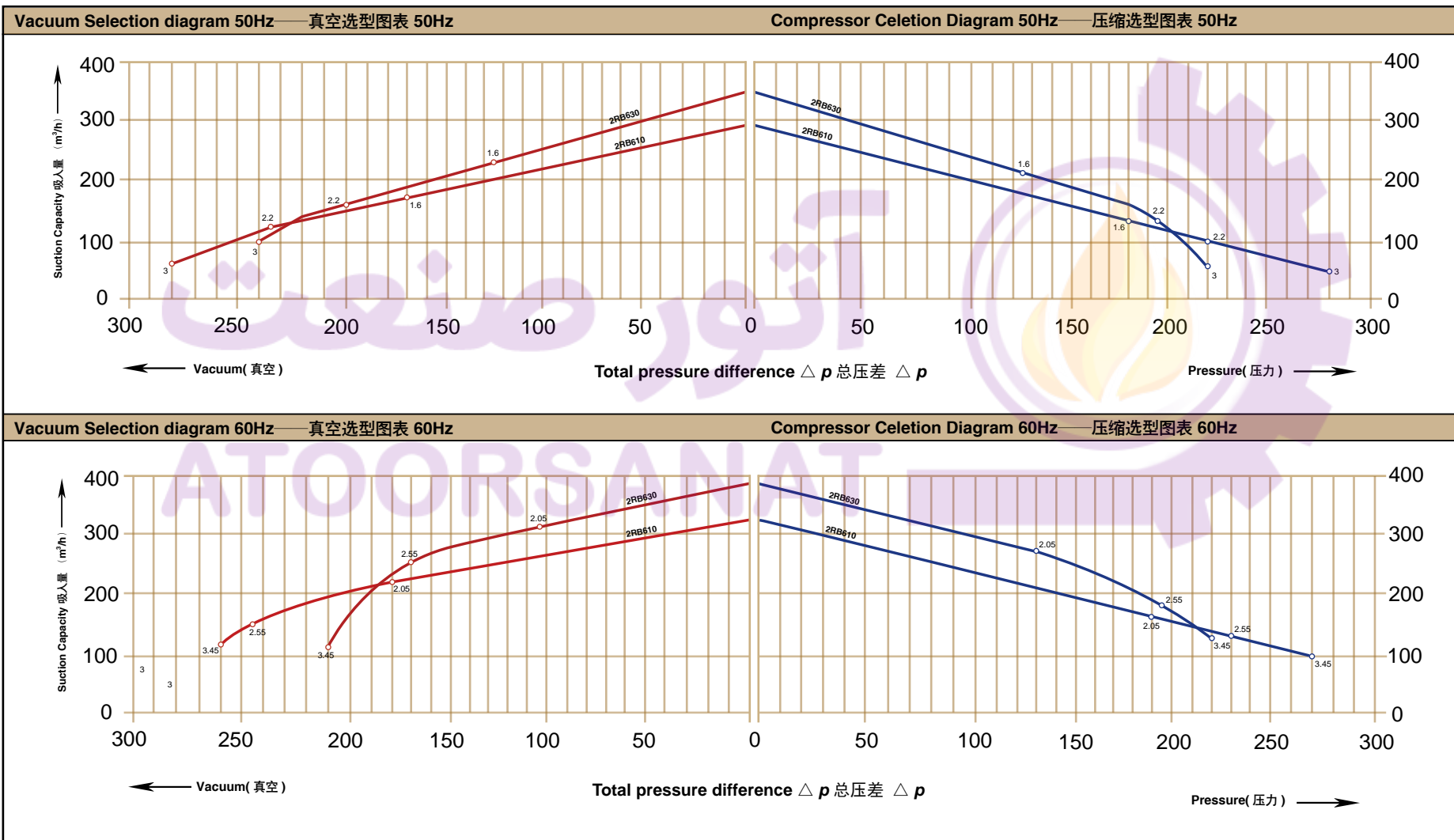

2RB7 3AC

G 系列 • G-Series

漩涡式气泵在真空和压力操作的选型和订购参数。

Selection and ordering data for side channel blowers in vacuum and pressure operation.

订购型号 • 有库存	马达			重量	噪音	最大流量	最高真空	最高压力	真空阀	
	输出功率	电压	电流						类型 × 型号	
Order No. • available ex stock	Fre-quency	MOTOR			weight approx	Sound- pressure level	Maximum airflow	Maximum vacuum	Maximum pressure	Vacuum rellet valve
		output	voltage	current						KG
• 2RB 710-7AH06	50	1.6	200-240 △ /345-415	8.5 △ /4.9Y	27	69	318	-160	150	1x...2110/...2145
	60	2.05	220-275 △ /380-480	8.5 △ /5.1Y		72	376	-160	150	1x...2114/...2146
• 2RB 710-7AH16	50	2.2	200-240 △ /345-415	9.7 △ /5.6Y	30	69	318	-190	190	1x...2110/...2145
	60	2.55	220-275 △ /380-480	10.3 △ /6.0Y		72	376	-190	190	1x...2114/...2146
• 2RB 710-7AH26	50	3.0	200-240 △ /345-415	12.5 △ /7.2Y	36	69	318	-260	270	1x...2110/...2145
	60	3.45	220-275 △ /380-480	12.6 △ /7.3Y		72	376	-240	230	1x...2114/...2146
• 2RB 710-7AH37	50	4.0	345-415 △ /600-720	9.0 △ /5.2Y	40	73	318	-290	360	1x...2110/...2145
	60	4.6	380-480 △ /660-720	9.0 △ /5.2Y		76	376	-320	310	1x...2114/...2146
• 2RB 720-7HH16	50	2.2	200-240 △ /345-415	9.7 △ /5.6Y	43	58	320	-220	210	1x2Bx2110/...2145
	60	2.55	220-275 △ /380-480	10.3 △ /6.0Y		60	380	-170	150	2x2Bx2114/...2146
• 2RB 720-7HH26	50	3.0	200-240 △ /345-415	12.5 △ /7.2Y	48	73	320	-280	260	1x2Bx2110/...2145
	60	3.45	220-275 △ /380-480	12.6 △ /7.3Y		76	380	-230	200	2x2Bx2114/...2146
• 2RB 720-7HH37	50	4.3	345-415 △ /600-720	10.0 △ /5.2Y	54	73	320	-360	380	1x2Bx2110/...2145
	60	4.8	380-480 △ /660-720	10.4 △ /6.0Y		76	380	-350	320	1x2Bx2114/...2146
• 2RB 720-7HH47	50	5.5	345-415 △ /600-720	13.3 △ /7.7Y	66	73	320	-440	500	1x2Bx2110/...2145
	60	6.3	380-480 △ /660-720	13.3 △ /7.7Y		76	380	-440	500	1x2Bx2114/...2146
• 2RB 720-7HH57	50	7.5	345-415 △ /600-720	16.7 △ /9.6Y	73	73	320	-440	570	1x2Bx2110/...2145
	60	8.6	380-480 △ /660-720	17.3 △ /10.0Y		76	380	-460	660	1x2Bx2114/...2146
• 2RB 730-7AH06	50	1.6	200-240 △ /345-415	8.5 △ /4.9Y	29	70	420	-100	100	1x...2110/...2145
	60	2.05	220-275 △ /380-480	8.8 △ /5.1Y		73	500	-110	100	3x...2114/...2146
• 2RB 730-7AH16	50	2.2	200-240 △ /345-415	9.7 △ /5.6Y	32	70	420	-180	170	1x...2110/...2145
	60	2.55	220-275 △ /380-480	10.3 △ /6.0Y		73	500	-160	150	2x...2114/...2146
• 2RB 730-7AH26	50	3.0	200-240 △ /345-415	12.5 △ /7.2Y	37	70	420	-220	200	1x...2110/...2145
	60	3.45	220-275 △ /380-480	12.6 △ /7.3Y		73	500	-200	170	2x...2114/...2146
• 2RB 730-7AH37	50	4.0	345-415 △ /600-720	9.0 △ /5.2Y	43	70	420	-260	280	1x...2110/...2145
	60	4.6	380-480 △ /660-720	9.0 △ /5.2Y		73	500	-260	260	2x...2114/...2146
• 2RB 740-7GH37	50	4.0	345-415 △ /600-720	9.0 △ /5.2Y	54	74	500	-150	140	1x2Bx2110/...2145
	60	4.6	380-480 △ /660-720	9.0 △ /5.2Y		78	600	-100	90	2x2Bx2114/...2146
• 2RB 740-7GH47	50	5.5	345-415 △ /600-720	13.3 △ /7.7Y	69	74	500	-240	260	1x2Bx2110/...2145
	60	6.3	380-480 △ /660-720	13.3 △ /7.7Y		78	600	-210	200	2x2Bx2114/...2146
• 2RB 740-7GH57	50	7.5	345-415 △ /600-720	16.7 △ /9.6Y	75	74	500	-240	320	1x2Bx2110/...2145
	60	8.6	380-480 △ /660-720	17.3 △ /10.0Y		78	600	-270	300	1x2Bx2114/...2146
• 2RB 790-7AH26	50	2.2	200-240 △ /345-415	12.5 △ /7.2Y	36	69	320	-160	200	—
	60	3.45	220-275 △ /380-480	12.6 △ /7.3Y		72	370	-240	250	—

2RB7 Series Selection diagram 50/60Hz 3AC

2RB7 系列 50/60Hz 选型图表 3AC



下面的性能曲线是在抽吸 15°C 空气，排气压力 1013mbar 的工况下测出的，允差 ±10%，吸入空气和环境温度不超过 25°C 时，即可达到图示总压差。

The performance curves are valid for pumping air at 15°C at the inlet flanges with an air pressure of 1.013mbar and a tolerance of ±10%. The total pressure differences are valid up to an intake and ambient temperature of 25°C.

Vacuum Selection diagram 50Hz — 真空选型图表 50Hz

Compressor Selection Diagram 50Hz — 压缩选型图表 50Hz

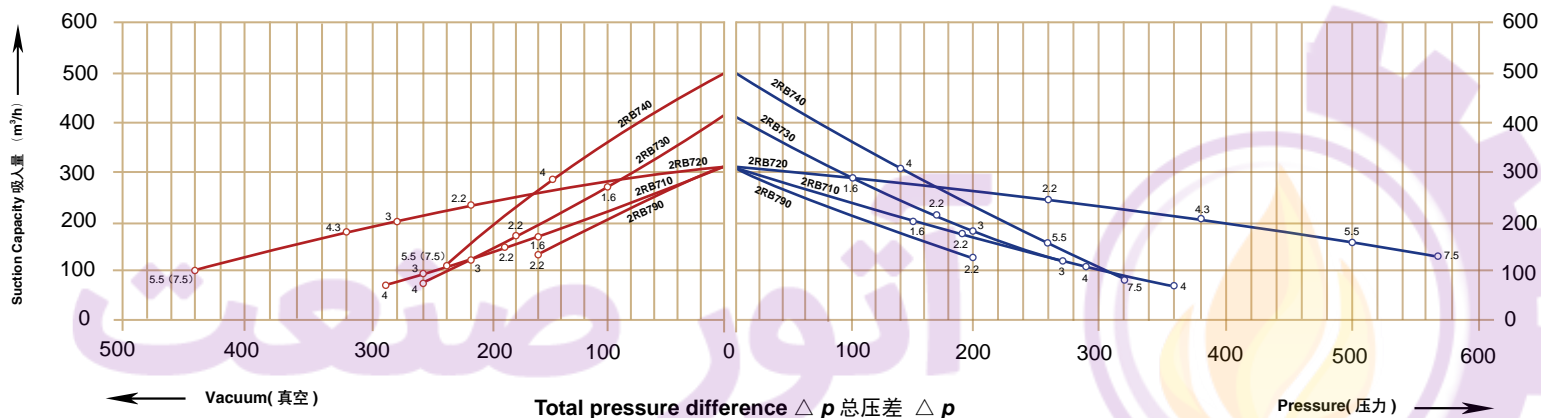

Vacuum Selection diagram 60Hz — 真空选型图表 60Hz

Compressor Selection Diagram 60Hz — 压缩选型图表 60Hz

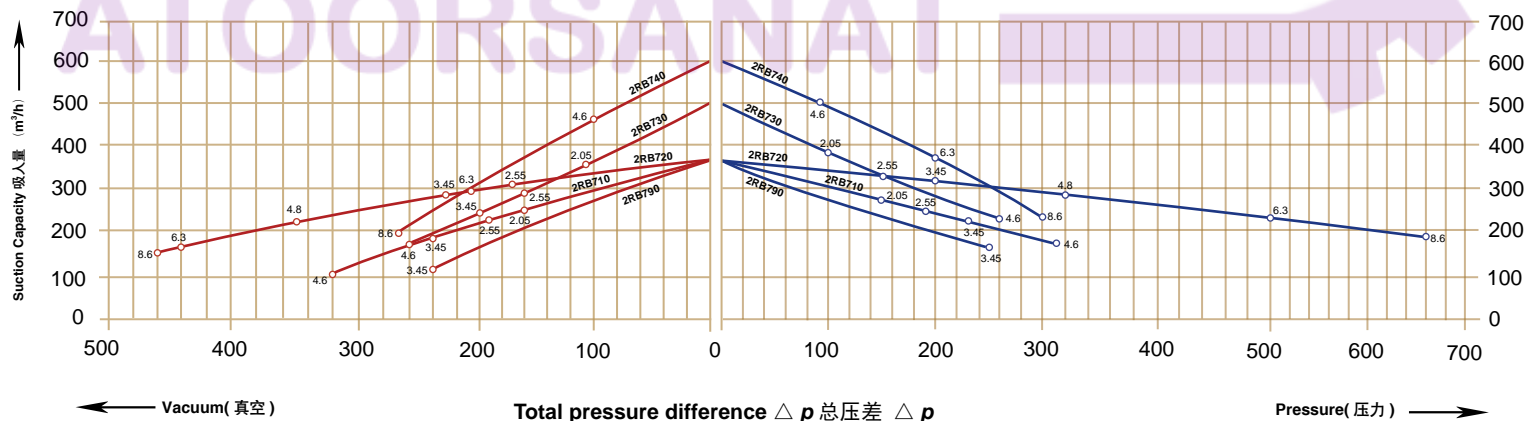

2RB8 3AC

G 系列 · G-Series

漩涡式气泵在真空和压力操作的选型和订购参数。

Selection and ordering data for side channel blowers in vacuum and pressure operation.

订购型号	马 达				重量	噪音	最大流量	最高真空	最高压力	真空阀
· 有库存	输出功率	额 定		类型 × 型号						
			电 压		电 流					
Order No.	MOTOR				Weight approx	Sound-Pressure level	Maximum airflow	Maximum vacuum	Maximum pressure	Vacuum relief valve
· available ex stock	Fre-quency	Rated								Items × type
		output	voltage	current						
	HZ	KW	V	A	KG	dB(A)	m³/h	mbar	mbar	
· 2RB 810-7AH07	50	4.0	345-415 △ /600-720	9.5 △ /5.5Y	54	70	530	-200	200	1x2Bx4740/...4840
	60	4.6	380-480 △ /660-720	9.5 △ /5.5Y		74	620	-160	160	1x2Bx4744/...4844
· 2RB 810-7AH17	50	5.5	345-415 △ /600-720	12.9 △ /7.4Y	63	70	530	-300	300	1x2Bx4740/...4840
	60	6.3	380-480 △ /660-720	12.9 △ /7.45Y		74	620	-300	280	1x2Bx4744/...4844
· 2RB 810-7AH27	50	7.5	345-415 △ /600-720	16.7 △ /9.6Y	66	70	530	-320	430	1x2Bx4740/...4840
	60	8.6	380-480 △ /660-720	17.3 △ /10.0Y		74	620	-350	400	1x2Bx4744/...4844
· 2RB 820-7HH17	50	5.5	345-415 △ /600-720	13.3 △ /7.7Y	83	74	520	-250	240	1x2Bx4740/...4840
	60	6.3	380-480 △ /660-720	13.3 △ /7.7Y		78	620	-170	160	1x2Bx4744/...4844
· 2RB 820-7HH27	50	7.5	345-415 △ /600-720	16.7 △ /9.6Y	86	74	520	-400	400	1x2Bx4740/...4840
	60	8.6	380-480 △ /660-720	17.3 △ /10.0Y		78	620	-360	330	1x2Bx4744/...4844
· 2RB 820-7HH37	50	11.0	345-415 △ /600-720	28.0 △ /16.2Y	104	74	520	-430	600	1x2Bx4740/...4840
	60	12.6	380-480 △ /660-720	29.0 △ /16.7Y		78	620	-460	600	1x2Bx4744/...4844
· 2RB 820-7HH47	50	15.0	345-415 △ /600-720	32.5 △ /18.8Y	120	74	520	-460	670	1x2Bx4740/...4840
	60	17.3	380-480 △ /660-720	34.5 △ /19.9Y		78	620	-490	750	1x2Bx4744/...4844
· 2RB 830-7AH07	50	4.0	345-415 △ /600-720	9.5 △ /5.5Y	57	70	700	-150	140	1x2Bx2110/...2145
	60	4.6	380-480 △ /660-720	9.5 △ /5.5Y		74	840	-90	90	1x2Bx4744/...4844
· 2RB 830-7AH17	50	5.5	345-415 △ /600-720	12.9 △ /7.4Y	66	70	700	-200	190	1x2Bx2110/...2145
	60	6.3	380-480 △ /660-720	12.9 △ /7.45Y		74	840	-180	180	1x2Bx4744/...4844
· 2RB 830-7AH27	50	7.6	345-415 △ /600-720	16.7 △ /9.6Y	69	70	700	-270	260	1x2Bx2110/...2145
	60	8.6	380-480 △ /660-720	17.3 △ /10.0Y		74	840	-270	260	1x2Bx4744/...4844
· 2RB 840-7GH27	50	7.5	345-415 △ /600-720	16.7 △ /9.6Y	91	74	900	-200	180	1x2Bx4744/...4840
	60	8.6	380-480 △ /660-720	17.3 △ /10.0Y		78	1050	-150	120	1x2Bx4744/...4844
· 2RB 840-7GH37	50	11.0	345-415 △ /600-720	28.0 △ /16.2Y	110	74	900	-280	370	1x2Bx4740/...4840
	60	12.6	380-480 △ /660-720	29.0 △ /16.7Y		78	1050	-310	350	1x2Bx4744/...4844

2RB8 Series Selection diagram 50/60Hz 3AC

2RB8 系列 50/60Hz 选型图表 3AC



下面的性能曲线是在抽吸 15°C 空气，排气压力 1013mbar 的工况下测出的，允差 ±10%，吸入空气和环境温度不超过 25°C 时，即可达到图示总压差。

The performance curves are valid for pumping air at 15°C at the inlet flanges with an air pressure of 1.013mbar and a tolerance of ±10%. The total pressure differences are valid up to an intake and ambient temperature of 25°C.

G-200

Vacuum Selection diagram 50Hz — 真空选型图表 50Hz

Compressor Selection Diagram 50Hz — 压缩选型图表 50Hz

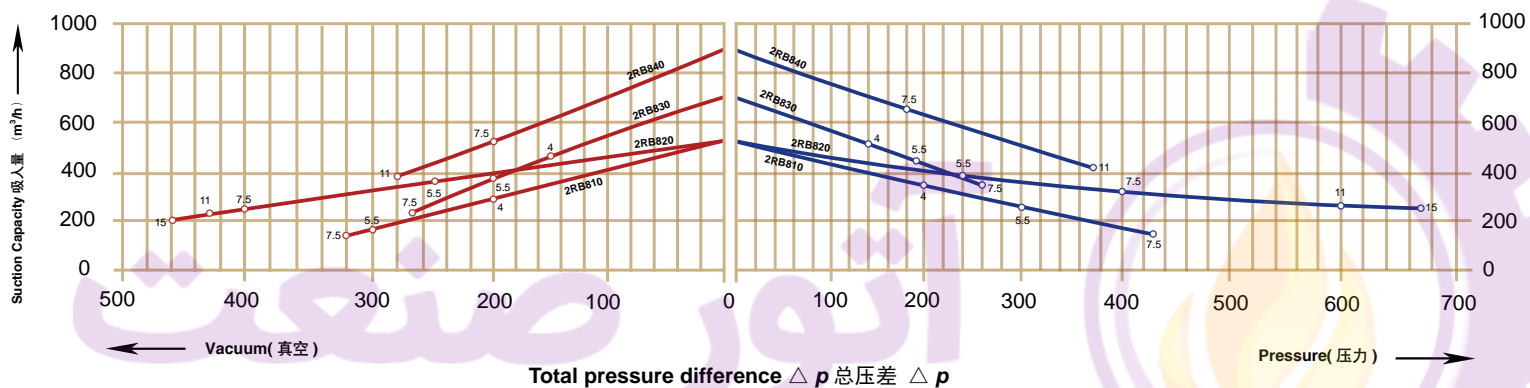

Vacuum Selection diagram 60Hz — 真空选型图表 60Hz

Compressor Selection Diagram 60Hz — 压缩选型图表 60Hz

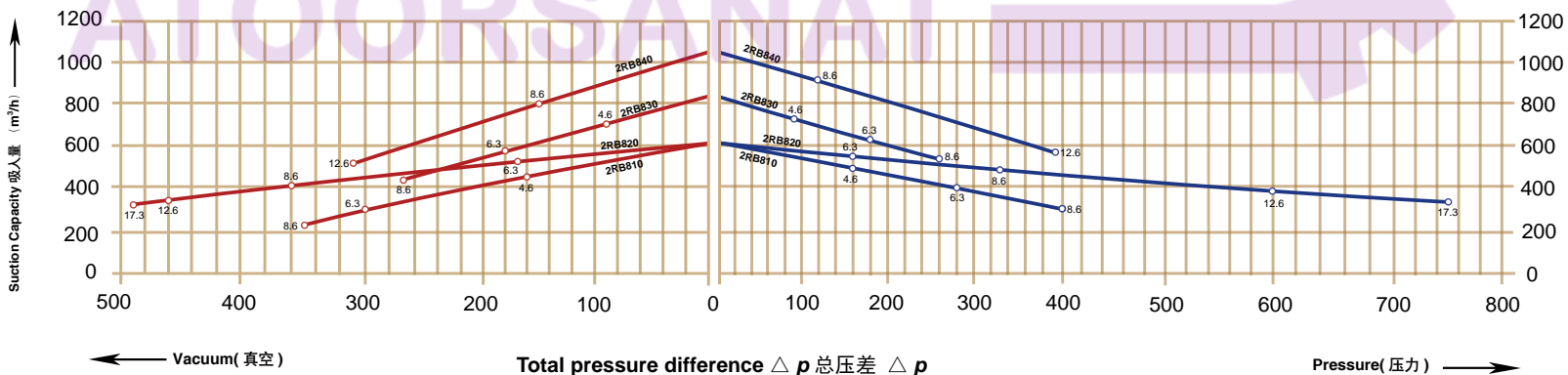

2RB9 3AC

G 系列 · G-Series

漩涡式气泵在真空和压力操作的选型和订购参数。

Selection and ordering data for side channel blowers in vacuum and pressure operation.

订购型号	马 达				重量	噪音	最大流量	最高真空	最高压力	真空阀
	· 有库存	额 定								类型 × 型号
		输出功率	电 压	电 流						
Order No.	MOTOR				Weight approx	Sound-Pressure level	Maximum airflow	Maximum vacuum	Maximum pressure	Vacuum relief valve
· available ex stock	Fre-quency	Rated		current						Items × type
	HZ	KW	V	A	KG	dB(A)	m³/h	mbar	mbar	
· 2RB 910-7AH07	50	8.5		18.2 △ /10.5Y	93	74	1050	-190	190	1×750/...860
	60	9.8	380-480 △ /660-720	18.2 △ /10.5Y		79	1250	-150	140	1×754/...864
· 2RB 910-7AH17	50	12.5	345-415 △ /600-720	28.0 △ /16.2Y	116	74	1050	-290	280	1×750/...860
	60	14.5	380-480 △ /660-720	29.0 △ /16.7Y		79	1250	-270	260	1×754/...864
· 2RB 910-7AH37	50	18.5	345-415 △ /600-720	37.0 △ /21.0Y	126	74	1050	-360	460	1×750/...860
	60	21.3	380-480 △ /660-720	39.0 △ /22.5Y		79	1250	-380	420	1×754/...864
· 2RB 920-7HH17	50	12.5	345-415 △ /600-720	28.0 △ /16.2Y	187	74	1110	-300	270	1×750/...860
	60	14.5	380-480 △ /660-720	29.0 △ /16.7Y		78	1310	-220	200	1×754/...864
· 2RB 920-7HH27	50	16.5	345-415 △ /600-720	35.0 △ /20.0Y	197	74	1110	-410	370	1×750/...860
	60	19.0	380-480 △ /660-720	36.5 △ /21.0Y		78	1310	-340	300	1×754/...864
· 2RB 920-7HH37	50	20.0	345-415 △ /600-720	40.0 △ /23.0Y	204	74	1110	-440	500	1×750/...860
	60	23.0	380-480 △ /660-720	42.0 △ /24.2Y		78	1310	-440	430	1×754/...864
· 2RB 920-7HH47	50	25.0	345-415 △ /600-720	52.0 △ /30.0Y	211	74	1110	-440	590	1×750/...860
	60	29.0	380-480 △ /660-720	52.0 △ /30.0Y		78	1310	-440	540	1×754/...864
· 2RB 930-7AH07	50	8.5	345-415 △ /600-720	18.2 △ /10.5Y	98	75	1370	-120	110	2x...750/1x...880
	60	9.8	380-480 △ /660-720	18.2 △ /10.5Y		80	1650	-80	70	2x...754/1x...864
· 2RB 930-7AH17	50	12.5	345-415 △ /600-720	28.0 △ /16.2Y	121	75	1370	-190	180	1x...750/...880
	60	14.5	380-480 △ /660-720	39.0 △ /22.5 Y		80	1650	-150	150	1x...754/...864
· 2RB 930-7AH37	50	18.5	345-415 △ /600-720	37.0 △ /21.0Y	131	75	1370	-310	320	1x...750/...880
	60	21.3	380-480 △ /660-720	39.0 △ /22.5Y		80	1650	-300	280	1x...754/...864
· 2RB 940-7BH27	50	15.0	345-415 △ /600-720	35.0 △ /20.0Y	187	75	1940	-130	110	2x...750/1x...880
	60	17.5	380-480 △ /660-720	36.5 △ /21.0Y		84	2310	-60	40	2x...754/1x...864
· 2RB 940-7BH37	50	20.0	345-415 △ /600-720	40.0 △ /23.0Y	212	75	1940	-220	200	2x...750/1x...880
	60	23.0	380-480 △ /660-720	42.0 △ /24.2Y		84	2310	-160	130	2x...754/1x...864
· 2RB 940-7BH47	50	25.0	345-415 △ /600-720	52.0 △ /30.0Y	219	75	1940	-310	280	1x...750/...880
	60	29.0	380-480 △ /660-720	52.0 △ /30.0Y		84	2310	-270	220	1x...754/...864
· 2RB 943-7BH27 ¹⁾	50	15.0	345-415 △ /600-720	35.0 △ /20.0Y	220	75	2050	-160	170	2x...750/1x...870
	60	17.5	380-480 △ /660-720	36.5 △ /21.0Y		84	2480	-120	110	2x...754/1x...874
· 2RB 943-7BH37 ¹⁾	50	20.0	345-415 △ /600-720	40.0 △ /23.0Y	230	75	2050	-250	230	2x...750/1x...870
	60	23.0	380-480 △ /660-720	42.0 △ /24.2Y		84	2480	-190	180	2x...754/1x...874
· 2RB 943-7BH47 ¹⁾	50	25.0	345-415 △ /600-720	52.0 △ /30.0Y	235	75	2050	-310	280	2x...750/1x...870
	60	29.0	380-480 △ /660-720	52.0 △ /30.0Y		84	2480	-270	230	2x...754/1x...874

1) 仅可以使用前端盖安装 · mounting on the end-casing only

2RB9 Series Selection diagram 50/60Hz 3AC

2RB9 系列 50/60Hz 选型图表 3AC



下面的性能曲线是在抽吸 15°C 空气，排气压力 1013mbar 的工况下测出的，允差 ±10%，吸入空气和环境温度不超过 25°C 时，即可达到图示总压差。

The performance curves are valid for pumping air at 15°C at the inlet flanges with an air pressure of 1.013mbar and a tolerance of ±10%. The total pressure differences are valid up to an intake and ambient temperature of 25°C.

G-200

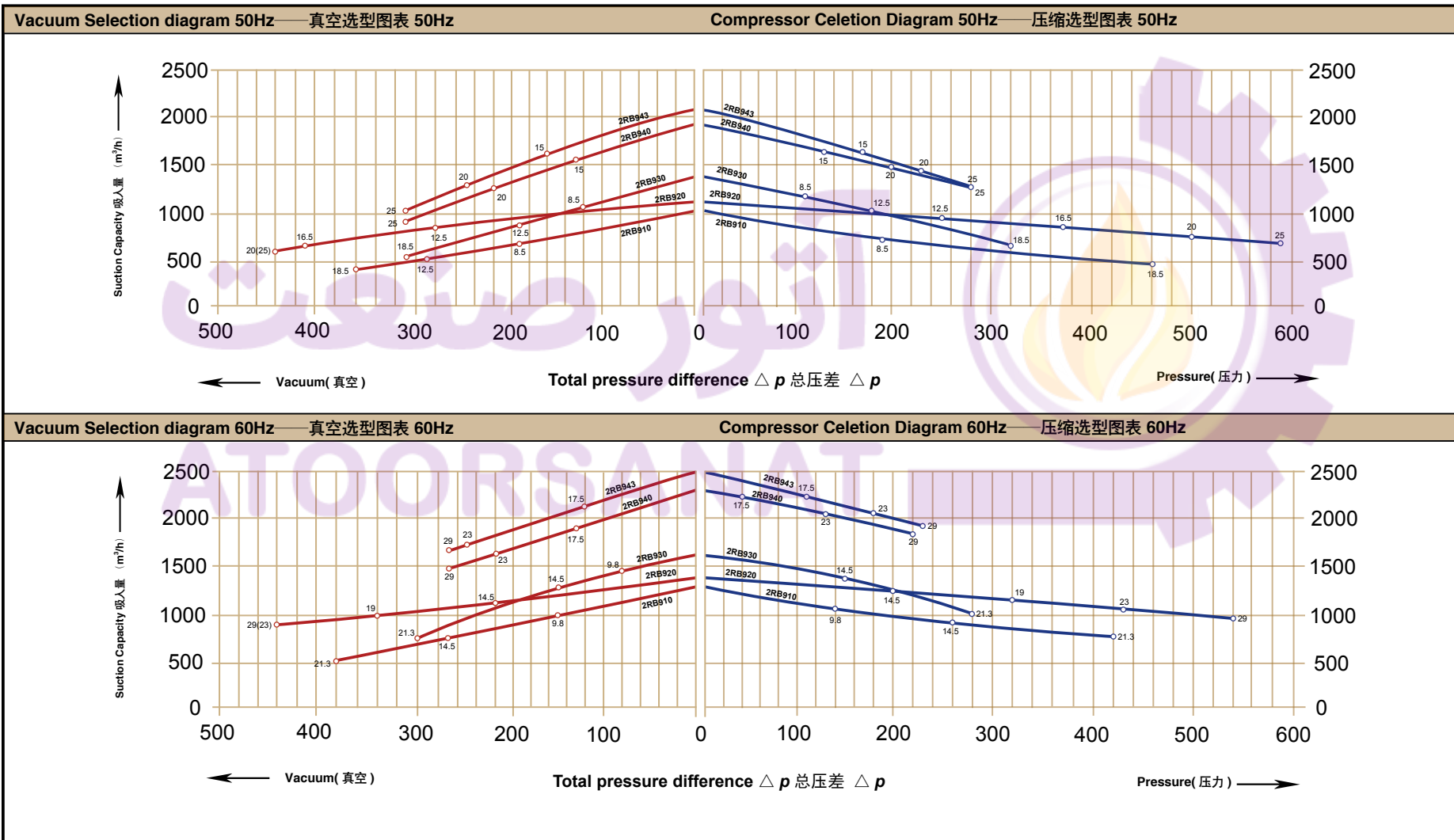

G-200 皮带式气环真空泵 / 压缩机

G-200 Bare shaft side channel vacuum pump/compressor

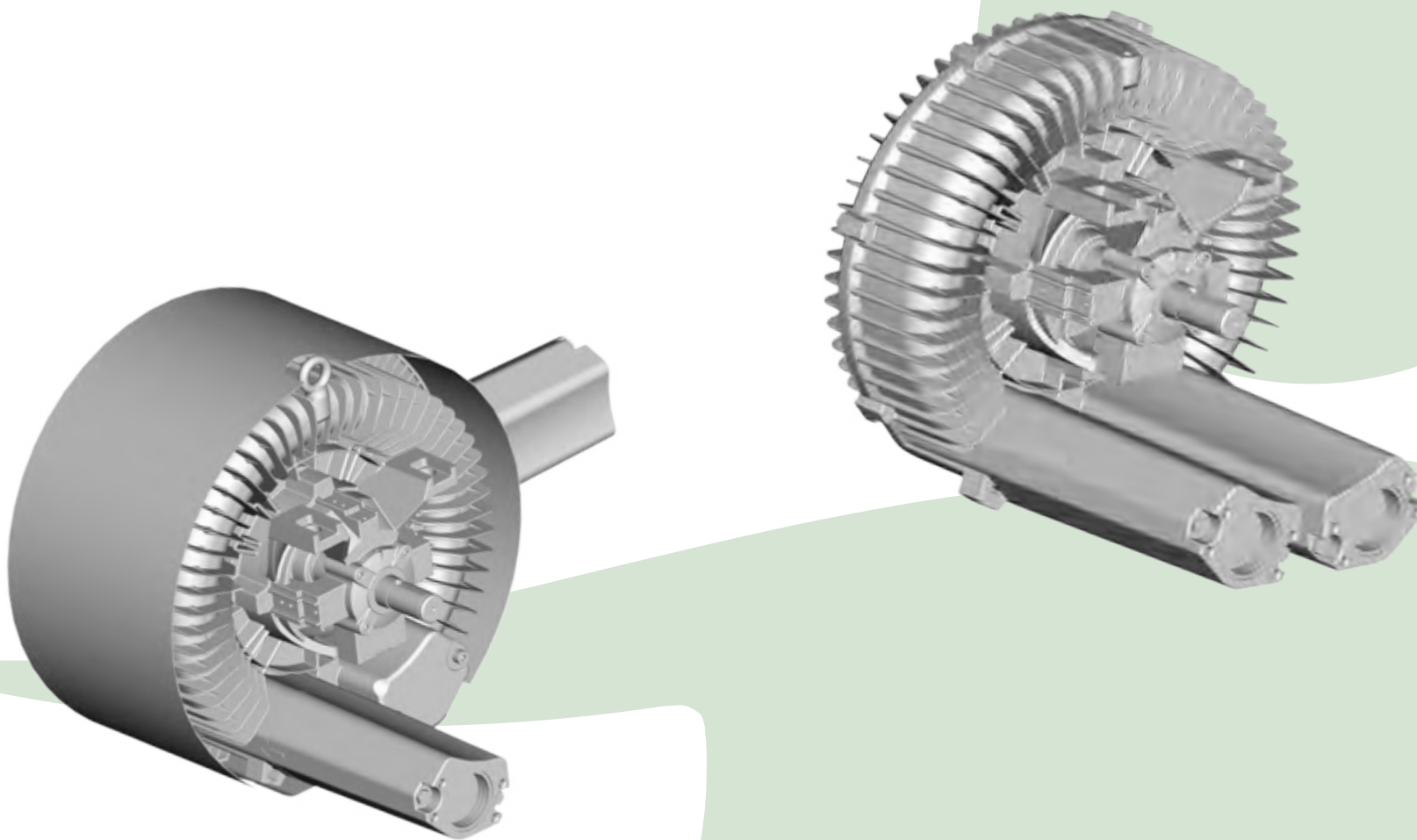



下面的性能曲线是在抽吸 15°C 空气，排气压力 1013mbar 的工况下测出的，允差 ±10%，吸入空气和环境温度不超过 25°C 时，即可达到图示总压差。

The performance curves are valid for pumping air at 15°C at the inlet flanges with an air pressure of 1.013mbar and a tolerance of ±10%. The total pressure differences are valid up to an intake and ambient temperature of 25°C.

NO	Rated Speed	Rated power	Maximim Air flow	Maximim vacuum	maximim pressure	Sound-level	Weight approx	Vacuum rellet
编号	转速	配置功率	最大流量	最大真空	最大压力	噪音	重量	Items×type
	RPM	KW	m³/h	mbar	mbar	dB(A)	Kg	2BX
1	3000	0.7	80	-130	130	53	5.5	1x...2110/...2141 (RV-01)
	3600	0.83	100	-160	160	56		
	4200	0.95	120	-170	170	60		
	5000	1.1	140	-180	170	62		

Vacuum Selection diagram —真空选型图表

Compressor Celetion Diagram —压缩选型图表

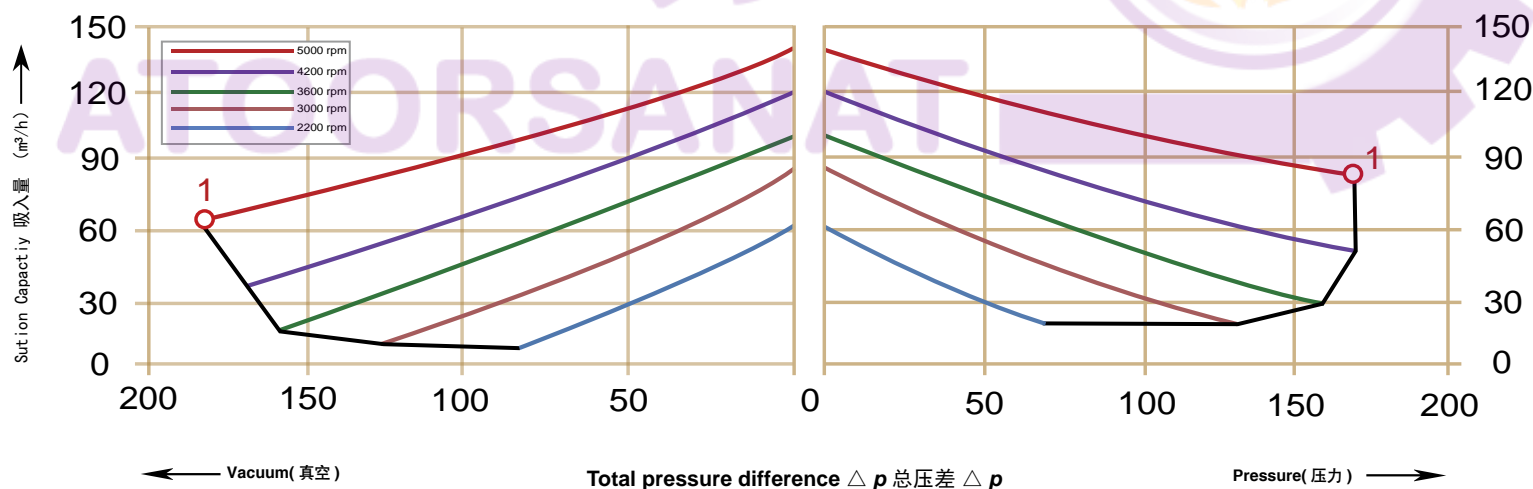

2RB 223-1HY99 Ordering data

2RB 223-1HY99 订购参数



下面的性能曲线是在抽吸 15°C 空气，排气压力 1013mbar 的工况下测出的，允差 ±10%，吸入空气和环境温度不超过 25°C 时，即可达到图示总压差。

The performance curves are valid for pumping air at 15°C at the inlet flanges with an air pressure of 1.013mbar and a tolerance of ±10%. The total pressure differences are valid up to an intake and ambient temperature of 25°C .

NO	Rated Speed	Rated power	Maximim Air flow	Maximim vacuum	maximim pressure	Sound-level	Weight approx	Vacuum rellet
编号	转速	配置功率	最大流量	最大真空	最大压力	噪音	重量	Items×type
	RPM	KW	m³/h	mbar	mbar	dB(A)	Kg	2BX
1	3000	0.7	85	-210	240	55	9	1x...2110/...2141 (RV-01)
	3600	0.83	102	-260	290	61		
	4200	0.95	128	-290	280	64		
	5000	1.1	150	-220	230	66		

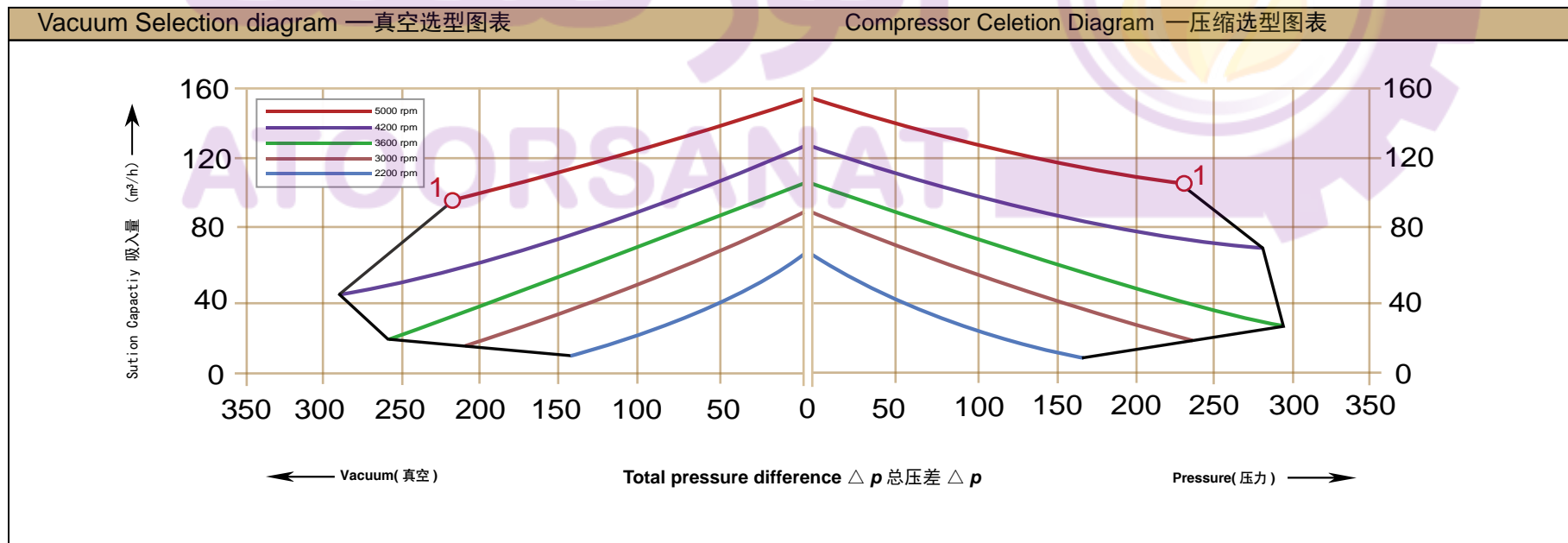

2RB 233-1HY99 Ordering data

2RB 233-1HY99 订购参数



下面的性能曲线是在抽吸 15°C 空气，排气压力 1013mbar 的工况下测出的，允差 ±10%，吸入空气和环境温度不超过 25°C 时，即可达到图示总压差。

The performance curves are valid for pumping air at 15°C at the inlet flanges with an air pressure of 1.013mbar and a tolerance of ±10%. The total pressure differences are valid up to an intake and ambient temperature of 25°C.

NO	Rated Speed	Rated power	Maximim Air flow	Maximim vacuum	maximim pressure	Sound-level	Weight approx	Vacuum rellet
编号	转速	配置功率	最大流量	最大真空	最大压力	噪音	重量	Items×type
	RPM	KW	m³/h	mbar	mbar	dB(A)	Kg	2BX
1	3000	0.7	105	-120	140	54	7	1x...2110/...2141 (RV-01)
	3600	0.83	120	-160	180	57		
	4200	0.95	140	-220	230	60		
	5000	1.1	170	-210	190	63		

Vacuum Selection diagram —真空选型图表

Compressor Celetion Diagram —压缩选型图表

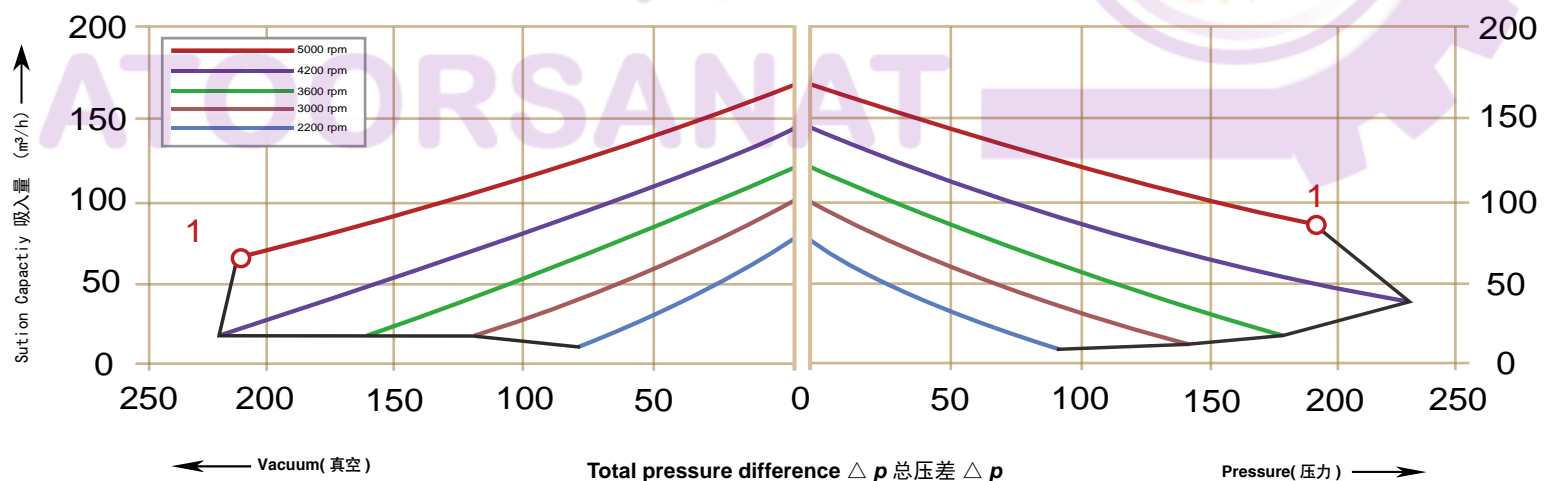

2RB 413-1HY99 Ordering data

2RB 413-1HY99 订购参数



下面的性能曲线是在抽吸 15°C 空气，排气压力 1013mbar 的工况下测出的，允差 ±10%，吸入空气和环境温度不超过 25°C 时，即可达到图示总压差。

The performance curves are valid for pumping air at 15°C at the inlet flanges with an air pressure of 1.013mbar and a tolerance of ±10%. The total pressure differences are valid up to an intake and ambient temperature of 25°C .

NO	Rated Speed	Rated power	Maximim Air flow	Maximim vacuum	maximim pressure	Sound-level	Weight approx	Vacuum rellet		
编号	转速	配置功率	最大流量	最大真空	最大压力	噪音	重量	Items×type		
	RPM	KW	m³/h	mbar	mbar	dB(A)	Kg	2BX		
1	3000	0.85	150	-160	160	63	7.5	1x...2110/...2141 (RV-01)		
	3600	0.95	180	-160	160	64				
	4200	1.3	220	-180	180	68				
	5000	1.5	250	-140	130	74				
2	3000	1.3	150	-170	200	63				
	3600	1.5	180	-210	200	64				
	4200	1.75	220	-210	190	68				
	5000	2.1	250	-190	190	74				

Vacuum Selection diagram —真空选型图表

Compressor Celetion Diagram —压缩选型图表

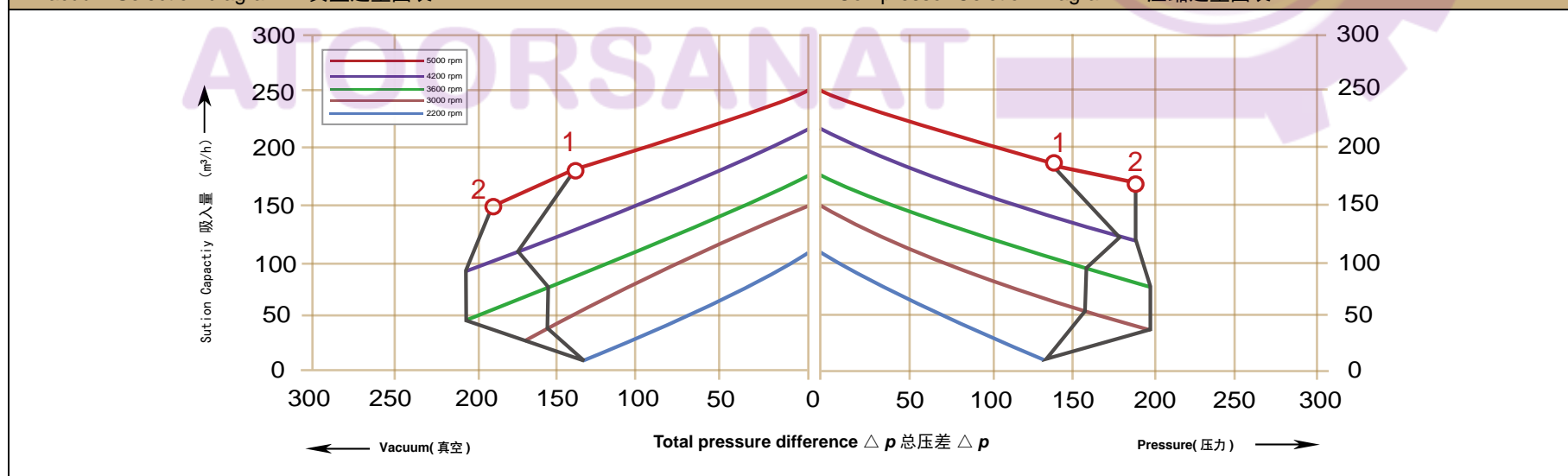

2RB 423-1HY99 Ordering data

2RB 423-1HY99 订购参数

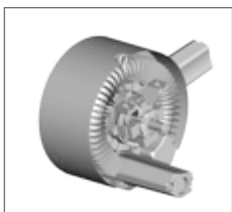

下面的性能曲线是在抽吸 15°C 空气，排气压力 1013mbar 的工况下测出的，允差 ±10%，吸入空气和环境温度不超过 25°C 时，即可达到图示总压差。

The performance curves are valid for pumping air at 15°C at the inlet flanges with an air pressure of 1.013mbar and a tolerance of ±10%. The total pressure differences are valid up to an intake and ambient temperature of 25°C.

NO	Rated Speed	Rated power	Maximim Air flow	Maximim vacuum	maximim pressure	Sound-level	Weight approx	Vacuum rellet
编号	转速	配置功率	最大流量	最大真空	最大压力	噪音	重量	Items×type
	RPM	KW	m³/h	mbar	mbar	dB(A)	Kg	2BX
1	3000	2.2	160	-330	440	66	13.5	1x...2110/...2142 (RV-02)
	3600	2.55	190	-350	420	69		
	4200	3.0	230	-420	400	72		
	5000	3.8	260	-380	330	77		

Vacuum Selection diagram — 真空选型图表

Compressor Celetion Diagram — 压缩选型图表

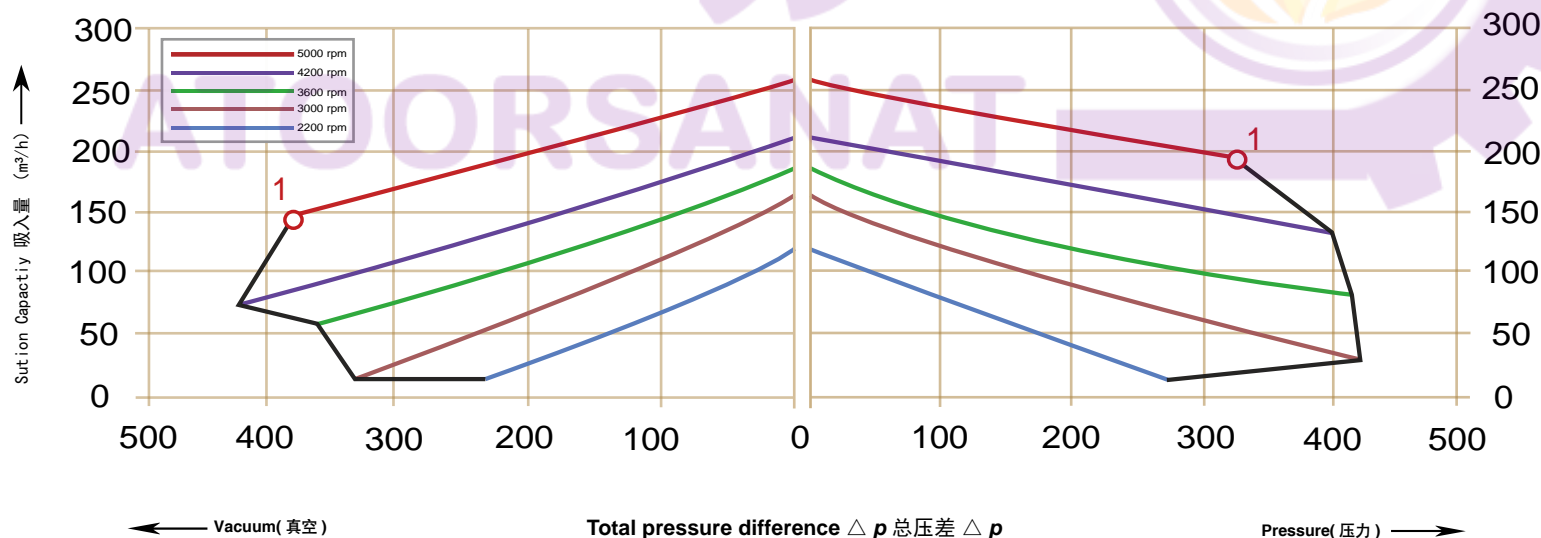

2RB 433-1HY99 Ordering data

2RB 433-1HY99 订购参数



下面的性能曲线是在抽吸 15°C 空气，排气压力 1013mbar 的工况下测出的，允差 ±10%，吸入空气和环境温度不超过 25°C 时，即可达到图示总压差。

The performance curves are valid for pumping air at 15°C at the inlet flanges with an air pressure of 1.013mbar and a tolerance of ±10%. The total pressure differences are valid up to an intake and ambient temperature of 25°C.

NO	Rated Speed	Rated power	Maximim Air flow	Maximim vacuum	maximim pressure	Sound-level	Weight approx	Vacuum rellet
编号	转速	配置功率	最大流量	最大真空	最大压力	噪音	重量	Items×type
	RPM	KW	m³/h	mbar	mbar	dB(A)	Kg	2BX
1	3000	1.3	180	-180	200	64	8.5	1x...2110/...2141 (RV-01)
	3600	1.5	210	-210	240	65		
	4200	1.75	255	-240	230	69		
	5000	2.1	300	-180	170	75		

Vacuum Selection diagram —真空选型图表

Compressor Celetion Diagram —压缩选型图表

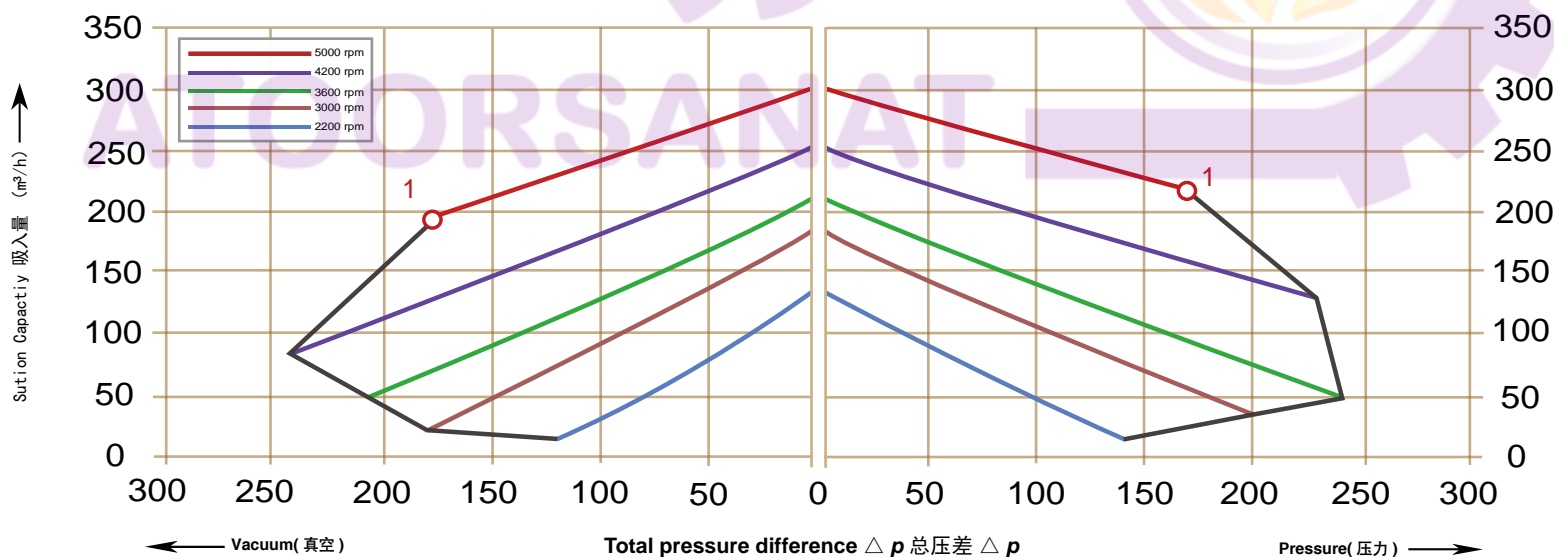

2RB 513-1HY99 Ordering data

2RB 513-1HY99 订购参数



下面的性能曲线是在抽吸 15°C 空气，排气压力 1013mbar 的工况下测出的，允差 ±10%，吸入空气和环境温度不超过 25°C 时，即可达到图示总压差。

The performance curves are valid for pumping air at 15°C at the inlet flanges with an air pressure of 1.013mbar and a tolerance of ±10%. The total pressure differences are valid up to an intake and ambient temperature of 25°C.

NO	Rated Speed	Rated power	Maximim Air flow	Maximim vacuum	Maximim pressure	Sound-level	Weight approx	Vacuum rellet
编号	转速	配置功率	最大流量	最大真空	最大压力	噪音	重量	Items×type
	RPM	KW	m³/h	mbar	mbar	dB(A)	Kg	2BX
1	3000	1.3	210	-170	170	64	11	1x...2110/...2141 (RV-01)
	3600	1.5	255	-150	140	70		
	4200	1.75	300	-130	100	72		
	5000	2.1	350	-70	60	75		
2	3000	1.6	210	-200	190	64		
	3600	2.05	255	-220	210	70		
	4200	2.3	300	-180	170	72		
	5000	2.6	350	-130	120	75		
3	3000	2.2	210	-220	270	64		
	3600	2.55	255	-260	290	70		
	4200	3.0	300	-300	270	72		
	5000	3.8	350	-270	240	75		

Vacuum Selection diagram —真空选型图表

Compressor Celetion Diagram —压缩选型图表

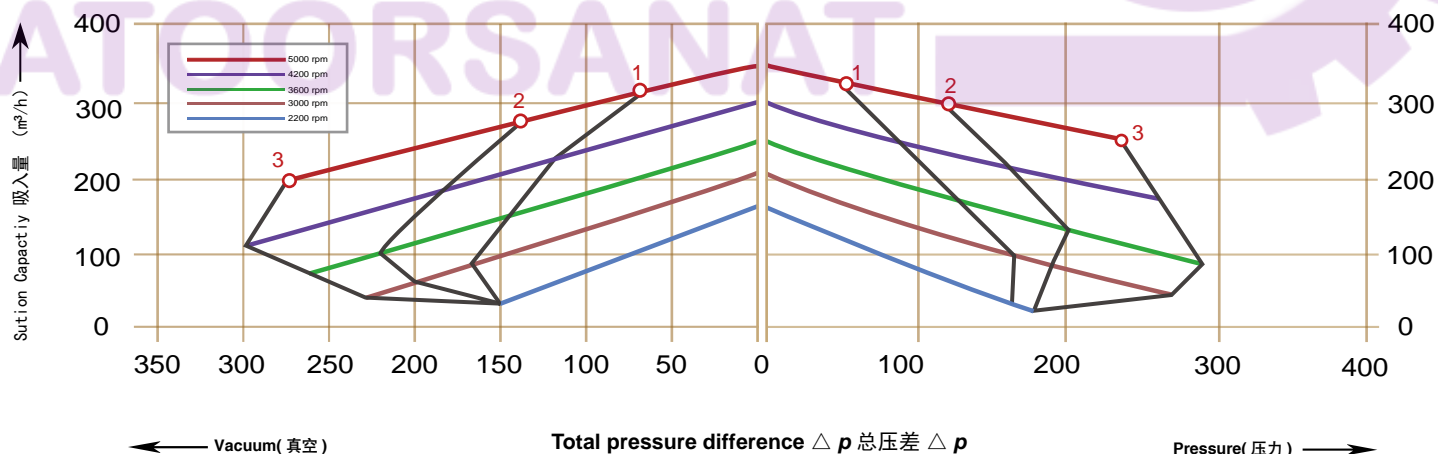

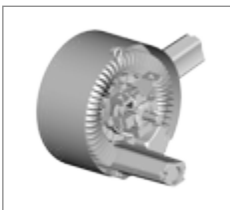

下面的性能曲线是在抽吸 15°C 空气，排气压力 1013mbar 的工况下测出的，允差 ±10%，吸入空气和环境温度不超过 25°C 时，即可达到图示总压差。

The performance curves are valid for pumping air at 15°C at the inlet flanges with an air pressure of 1.013mbar and a tolerance of ±10%. The total pressure differences are valid up to an intake and ambient temperature of 25°C.

NO	Rated Speed	Rated power	Maximim Air flow	Maximim vacuum	maximim pressure	Sound-level	Weight approx	Vacuum rellet		
编号	转速	配置功率	最大流量	最大真空	最大压力	噪音	重量	Items×type		
	RPM	KW	m³/h	mbar	mbar	dB(A)	Kg	2BX		
1	3000	3.0	230	-340	410	72	21	1x···2110/···2142 (RV-02)		
	3600	3.45	275	-380	360	74				
	4200	4.3	320	-340	300	78				
	5000	5.0	380	-300	240	83				
2	3000	4.0	230	-390	440	72				
	3600	4.6	275	-410	480	74				
	4200	6.0	320	-440	480	78				
	5000	6.9	380	-460	410	83				

Vacuum Selection diagram —真空选型图表

Compressor Celetion Diagram —压缩选型图表

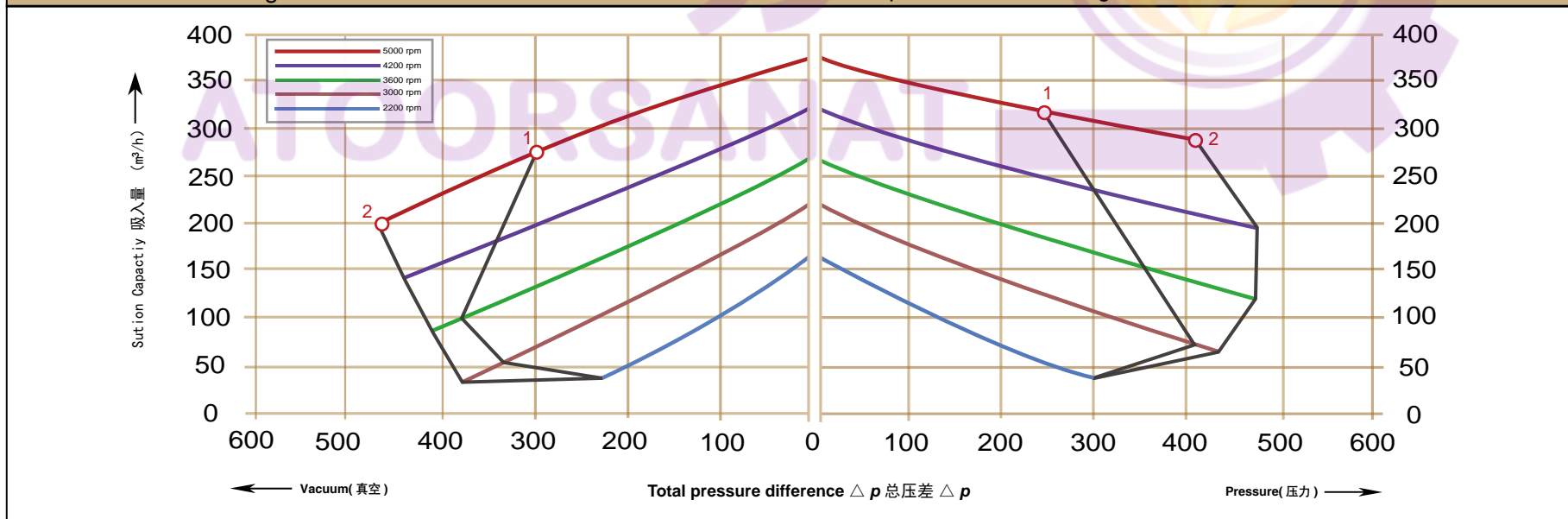



下面的性能曲线是在抽吸 15°C 空气，排气压力 1013mbar 的工况下测出的，允差 ±10%，吸入空气和环境温度不超过 25°C 时，即可达到图示总压差。

The performance curves are valid for pumping air at 15°C at the inlet flanges with an air pressure of 1.013mbar and a tolerance of ±10%. The total pressure differences are valid up to an intake and ambient temperature of 25°C.

NO	Rated Speed	Rated power	Maximim Air flow	Maximim vacuum	maximim pressure	Sound-level	Weight approx	Vacuum rellet
编号	转速	配置功率	最大流量	最大真空	最大压力	噪音	重量	Items × type
	RPM	KW	m³/h	mbar	mbar	dB(A)	Kg	2BX
1	3000	2.2	270	-220	230	65	12	2x...2110/...2141 (RV-01)
	3600	2.55	330	-260	250	71		
	4200	3.0	390	-270	250	73		
	5000	3.8	460	-230	220	76		

Vacuum Selection diagram — 真空选型图表

Compressor Celetion Diagram — 压缩选型图表

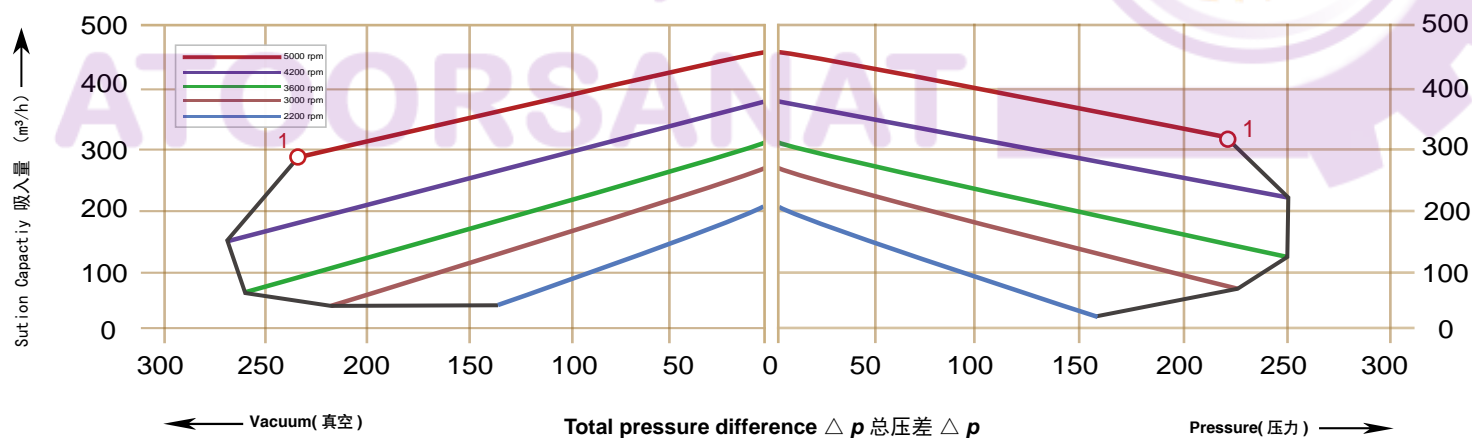



下面的性能曲线是在抽吸 15°C 空气，排气压力 1013mbar 的工况下测出的，允差 ±10%，吸入空气和环境温度不超过 25°C 时，即可达到图示总压差。

The performance curves are valid for pumping air at 15°C at the inlet flanges with an air pressure of 1.013mbar and a tolerance of ±10%. The total pressure differences are valid up to an intake and ambient temperature of 25°C .

NO	Rated Speed	Rated power	Maximim Air flow	Maximim vacuum	maximim pressure	Sound-level	Weight approx	Vacuum rellet		
编号	转速	配置功率	最大流量	最大真空	最大压力	噪音	重量	Items×type		
	RPM	KW	m³/h	mbar	mbar	dB(A)	Kg	2BX		
1	3000	2.2	265	-220	220	65	14	1x...2110/...2145 (RV-01)		
	3600	2.55	315	-250	240	71				
	4200	3.0	400	-240	250	73				
	5000	3.8	480	-180	190	76				
2	3000	3.0	265	-260	250	64				
	3600	3.45	315	-280	280	70				
	4200	4.3	400	-270	280	72				
	5000	5.0	480	-220	220	75				

Vacuum Selection diagram —真空选型图表

Compressor Celetion Diagram —压缩选型图表

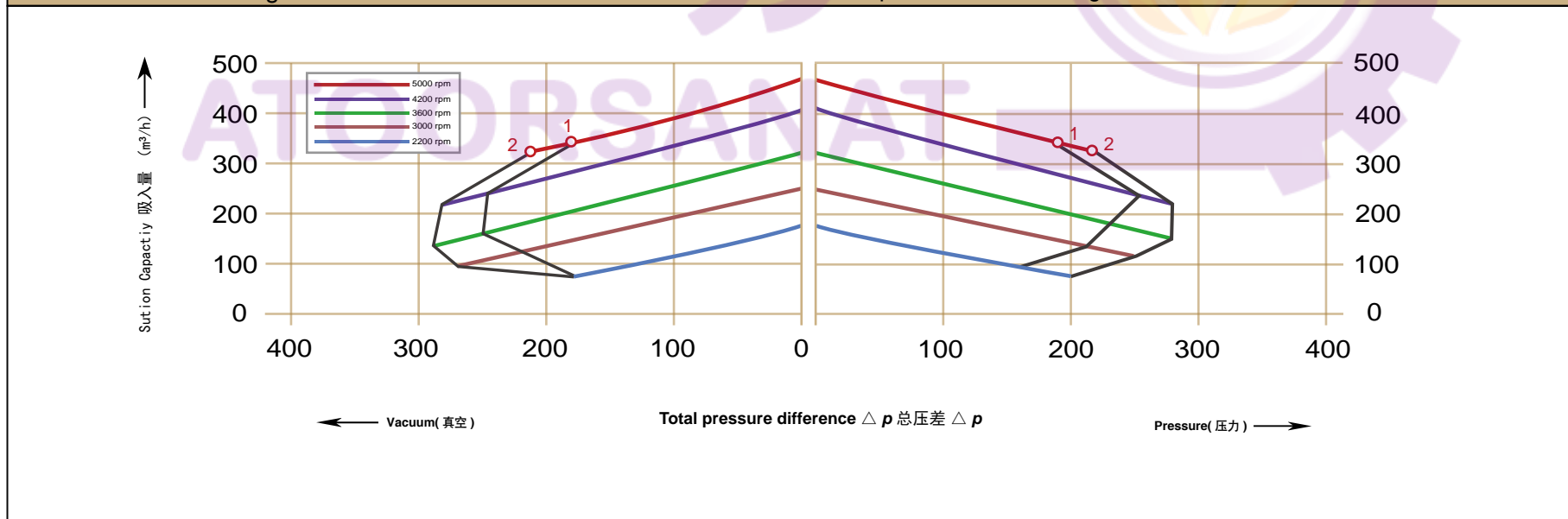

2RB 713-1HY99 Ordering data

2RB 713-1HY99 订购参数



下面的性能曲线是在抽吸 15°C 空气，排气压力 1013mbar 的工况下测出的，允差 ±10%，吸入空气和环境温度不超过 25°C 时，即可达到图示总压差。

The performance curves are valid for pumping air at 15°C at the inlet flanges with an air pressure of 1.013mbar and a tolerance of ±10%. The total pressure differences are valid up to an intake and ambient temperature of 25°C.

NO	Rated Speed	Rated power	Maximim Air flow	Maximim vacuum	maximim pressure	Sound-level	Weight approx	Vacuum rellet
编号	转速	配置功率	最大流量	最大真空	最大压力	噪音	重量	Items×type
	RPM	KW	m³/h	mbar	mbar	dB(A)	Kg	2BX
1	3000	2.2	320	-190	190	69	16	1x...2110/...2145
	3600	2.55	380	-190	190	72		
	4200	3.0	440	-160	160	75		
	5000	3.8	530	-130	130	80		
2	3000	3.0	320	-260	270	64		
	3600	3.45	380	-240	230	70		
	4200	4.3	440	-270	220	72		
	5000	5.0	530	-220	210	75		
3	3000	4.0	320	-290	360	64		
	3600	4.6	380	-320	310	70		
	4200	6.0	440	-340	300	72		
	5000	6.9	530	-300	270	75		

Vacuum Selection diagram —真空选型图表

Compressor Celetion Diagram —压缩选型图表

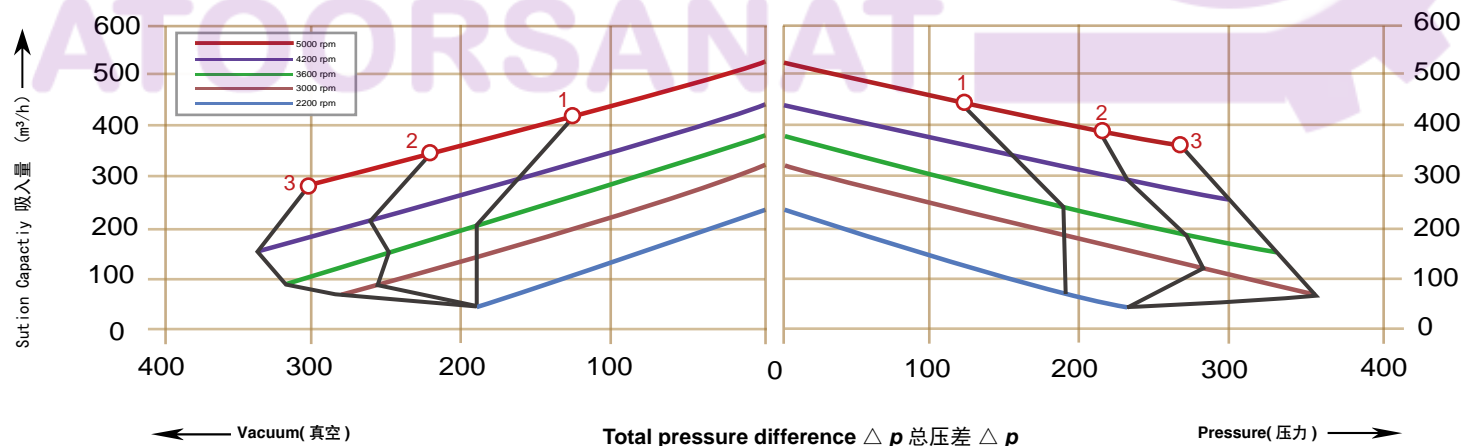

2RB 723-1HY99 Ordering data

2RB 723-1HY99 订购参数

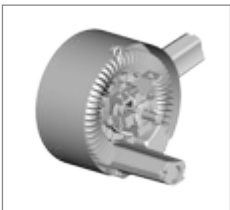

下面的性能曲线是在抽吸 15°C 空气，排气压力 1013mbar 的工况下测出的，允差 ±10%，吸入空气和环境温度不超过 25°C 时，即可达到图示总压差。

The performance curves are valid for pumping air at 15°C at the inlet flanges with an air pressure of 1.013mbar and a tolerance of ±10%. The total pressure differences are valid up to an intake and ambient temperature of 25°C.

NO	Rated Speed	Rated power	Maximim Air flow	Maximim vacuum	maximim pressure	Sound-level	Weight approx	Vacuum rellet
编号	转速	配置功率	最大流量	最大真空	最大压力	噪音	重量	Items×type
	RPM	KW	m³/h	mbar	mbar	dB(A)	Kg	2BX
1	3000	4.3	320	-360	380	73	29	1x...2110/...2145
	3600	4.8	380	-350	320	75		
	4200	6.3	440	-310	300	78		
	5000	6.9	530	-240	200	84		
2	3000	5.5	320	-420	500	73		
	3600	6.3	380	-440	500	75		
	4200	7.5	440	-440	420	78		
	5000	8.8	530	-440	350	84		
3	3000	7.5	320	-440	570	73		
	3600	8.6	380	-460	660	75		
	4200	10.0	440	-460	600	78		
	5000	12.0	530	-440	410	84		

Vacuum Selection diagram —真空选型图表

Compressor Celetion Diagram —压缩选型图表

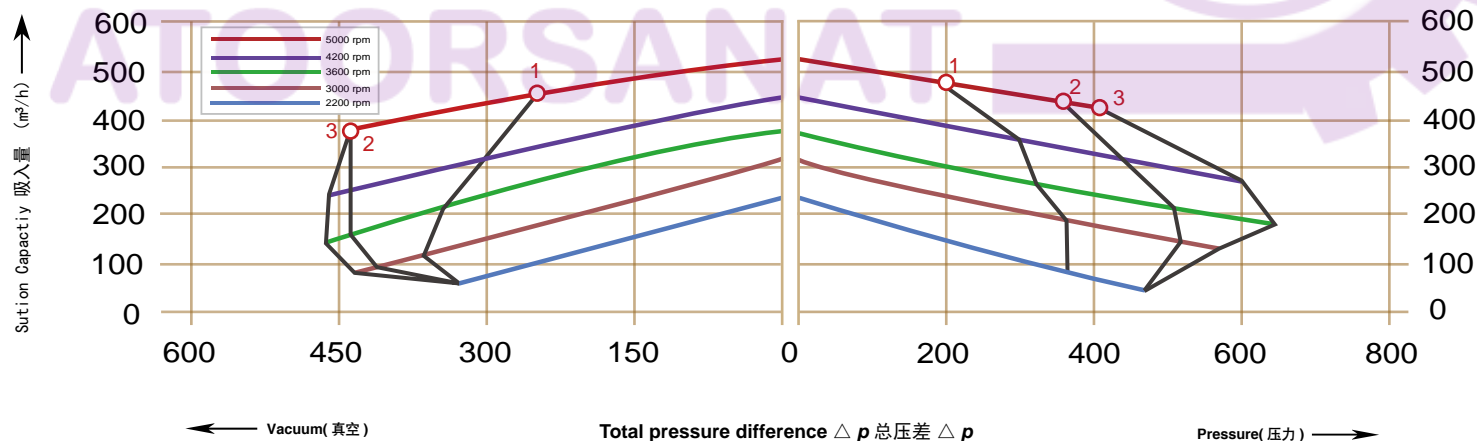

2RB 733-1HY99 Ordering data

2RB 733-1HY99 订购参数



下面的性能曲线是在抽吸 15°C 空气，排气压力 1013mbar 的工况下测出的，允差 ±10%，吸入空气和环境温度不超过 25°C 时，即可达到图示总压差。

The performance curves are valid for pumping air at 15°C at the inlet flanges with an air pressure of 1.013mbar and a tolerance of ±10%. The total pressure differences are valid up to an intake and ambient temperature of 25°C .

NO	Rated Speed	Rated power	Maximim Air flow	Maximim vacuum	maximim pressure	Sound-level	Weight approx	Vacuum rellet
编号	转速	配置功率	最大流量	最大真空	最大压力	噪音	重量	Items X type
	RPM	KW	m³/h	mbar	mbar	dB(A)	Kg	2BX
1	3000	2.2	420	-180	170	70	18	2x...2110/...2145
	3600	2.55	500	-160	150	73		
	4200	3.0	580	-140	130	76		
	5000	3.8	660	-120	120	81		
2	3000	3.0	420	-220	200	70		
	3600	3.45	500	-200	170	73		
	4200	4.3	580	-180	170	76		
	5000	5.0	660	-150	150	81		
3	3000	4.0	420	-260	290	70		
	3600	4.6	500	-260	260	73		
	4200	6.0	580	-260	260	76		
	5000	6.9	660	-260	240	81		

Vacuum Selection diagram —真空选型图表

Compressor Celetion Diagram —压缩选型图表

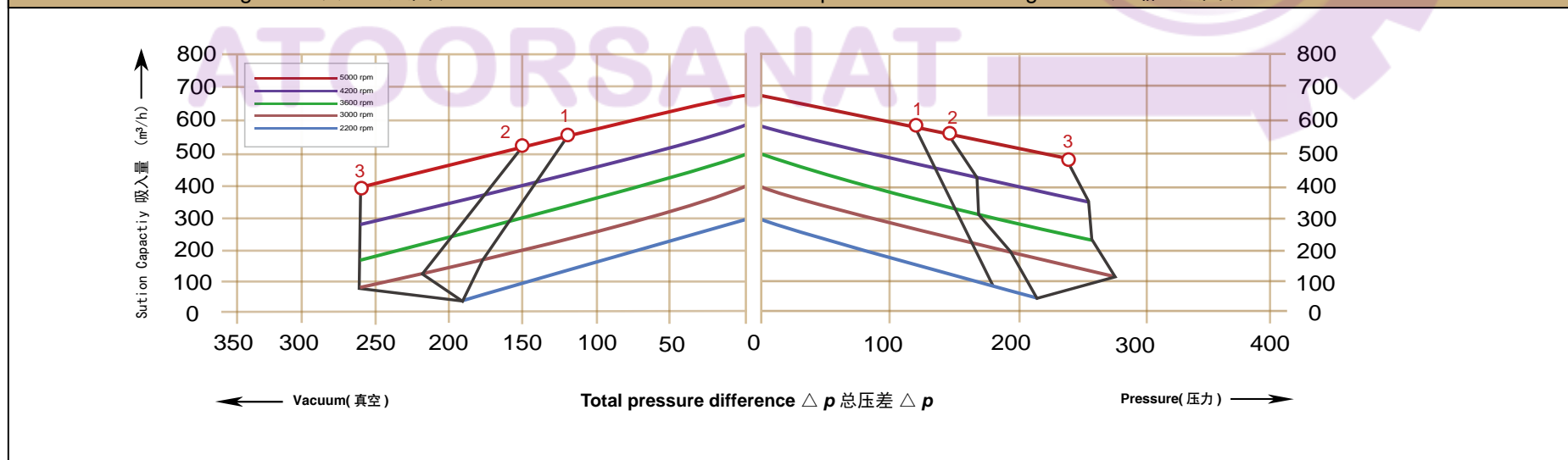

2RB 743-1HY99 Ordering data

2RB 743-1HY99 订购参数



下面的性能曲线是在抽吸 15°C 空气，排气压力 1013mbar 的工况下测出的，允差 ±10%，吸入空气和环境温度不超过 25°C 时，即可达到图示总压差。

The performance curves are valid for pumping air at 15°C at the inlet flanges with an air pressure of 1.013mbar and a tolerance of ±10%. The total pressure differences are valid up to an intake and ambient temperature of 25°C .

NO	Rated Speed	Rated power	Maximim Air flow	Maximim vacuum	maximim pressure	Sound-level	Weight approx	Vacuum rellet		
编号	转速	配置功率	最大流量	最大真空	最大压力	噪音	重量	Items×type		
	RPM	KW	m³/h	mbar	mbar	dB(A)	Kg	2BX		
1	3000	5.5	500	-240	260	74	31	2x...2110/...2145		
	3600	6.3	600	-210	200	78				
	4200	7.5	700	-140	120	80				
	5000	8.8	800	-50	30	84				
2	3000	7.5	500	-240	320	73				
	3600	8.6	600	-270	300	75				
	4200	10.0	700	-200	200	78				
	5000	12.0	800	-110	80	84				

Vacuum Selection diagram —真空选型图表

Compressor Celetion Diagram —压缩选型图表

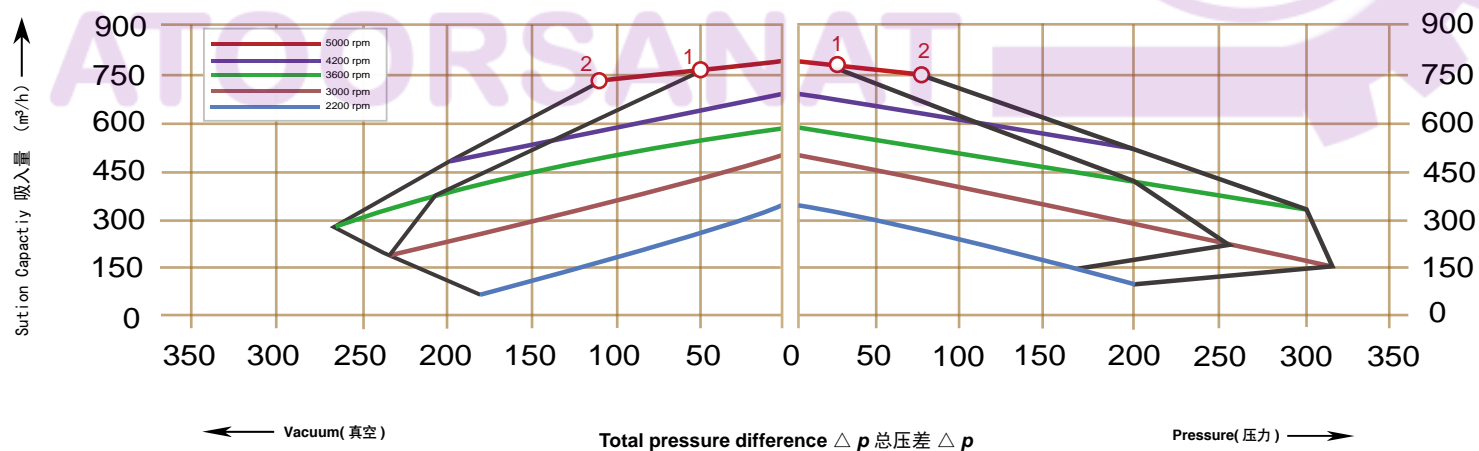

2RB 813-1HY99 Ordering data

2RB 813-1HY99 订购参数



下面的性能曲线是在抽吸 15°C 空气，排气压力 1013mbar 的工况下测出的，允差 ±10%，吸入空气和环境温度不超过 25°C 时，即可达到图示总压差。

The performance curves are valid for pumping air at 15°C at the inlet flanges with an air pressure of 1.013mbar and a tolerance of ±10%. The total pressure differences are valid up to an intake and ambient temperature of 25°C .

NO	Rated Speed	Rated power	Maximim Air flow	Maximim vacuum	maximim pressure	Sound-level	Weight approx	Vacuum rellet
编号	转速	配置功率	最大流量	最大真空	最大压力	噪音	重量	Items×type
	RPM	KW	m³/h	mbar	mbar	dB(A)	Kg	2BX
1	3000	4.0	530	-200	200	73	38	1x...4740/...4840
	3600	4.6	620	-160	160	75		
	4200	6.0	720	-150	150	78		
	5000	6.9	830	-140	140	84		
2	3000	5.5	530	-300	300	73		
	3600	6.3	620	-300	280	75		
	4200	7.5	720	-280	260	78		
	5000	8.8	830	-220	210	84		
3	3000	7.5	420	-320	430	73		
	3600	8.6	620	-350	400	75		
	4200	10.0	720	-320	370	78		
	5000	12.0	830	-270	330	84		

Vacuum Selection diagram —真空选型图表

Compressor Celetion Diagram —压缩选型图表

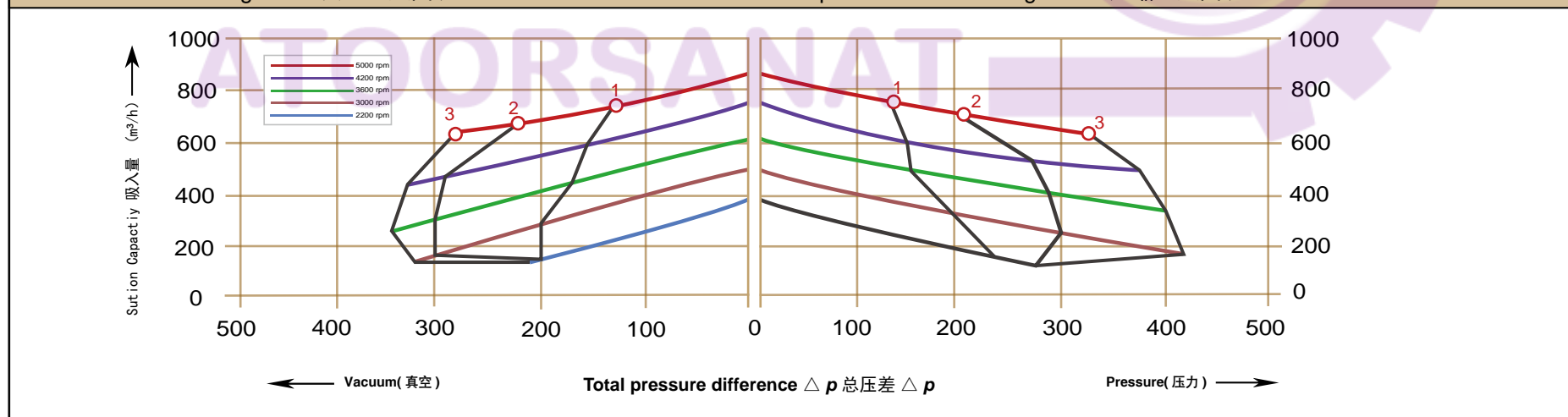

2RB 823-1HY99 Ordering data

2RB 823-1HY99 订购参数



下面的性能曲线是在抽吸 15°C 空气，排气压力 1013mbar 的工况下测出的，允差 ±10%，吸入空气和环境温度不超过 25°C 时，即可达到图示总压差。

The performance curves are valid for pumping air at 15°C at the inlet flanges with an air pressure of 1.013mbar and a tolerance of ±10%. The total pressure differences are valid up to an intake and ambient temperature of 25°C .

NO	Rated Speed	Rated power	Maximim Air flow	Maximim vacuum	maximim pressure	Sound-level	Weight approx	Vacuum rellet
编号	转速	配置功率	最大流量	最大真空	最大压力	噪音	重量	Items×type
	RPM	KW	m³/h	mbar	mbar	dB(A)	Kg	2BX
1	3000	7.5	520	-400	400	74	64	1x...4740/...4840
	3600	8.6	620	-360	330	78		
	4200	10.0	730	-240	220	81		
	5000	12.0	860	-100	80	84		
2	3000	11.0	520	-430	600	74		
	3600	12.6	620	-460	600	78		
	4200	14.5	730	-480	360	81		
	5000	17.6	860	-440	290	84		
3	3000	15.0	520	-460	670	74		
	3600	17.3	620	-490	750	78		
	4200	21.1	730	-480	680	81		
	5000	24.0	860	-440	520	84		

Vacuum Selection diagram —真空选型图表

Compressor Celetion Diagram —压缩选型图表

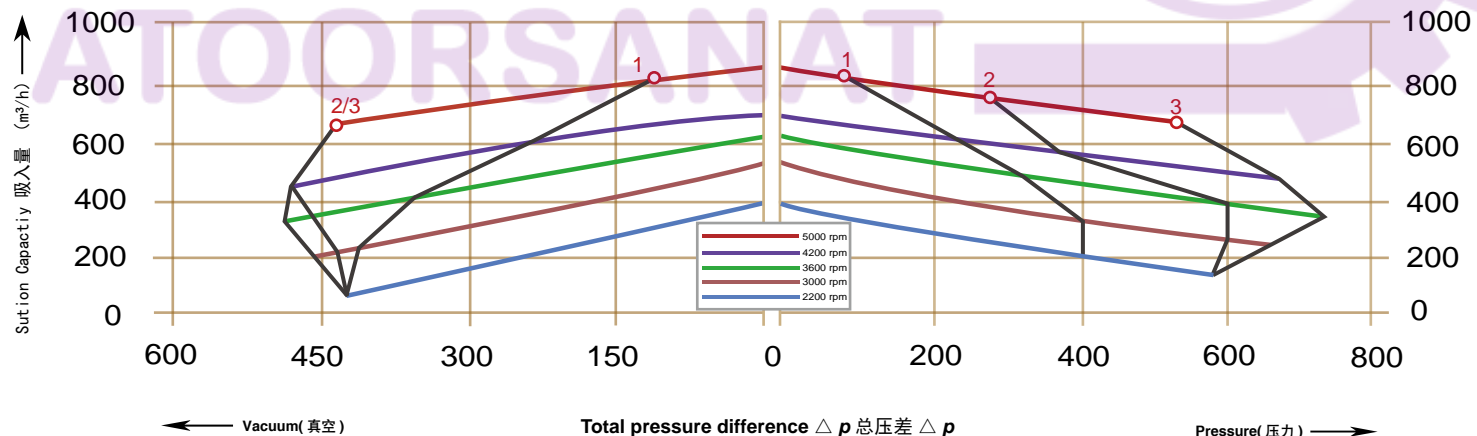

2RB 833-1HY99 Ordering data

2RB 833-1HY99 订购参数



下面的性能曲线是在抽吸 15°C 空气，排气压力 1013mbar 的工况下测出的，允差 ±10%，吸入空气和环境温度不超过 25°C 时，即可达到图示总压差。

The performance curves are valid for pumping air at 15°C at the inlet flanges with an air pressure of 1.013mbar and a tolerance of ±10%. The total pressure differences are valid up to an intake and ambient temperature of 25°C .

NO	Rated Speed	Rated power	Maximim Air flow	Maximim vacuum	maximim pressure	Sound-level	Weight approx	Vacuum rellet		
编号	转速	配置功率	最大流量	最大真空	最大压力	噪音	重量	Items×type		
	RPM	KW	m³/h	mbar	mbar	dB(A)	Kg	2BX		
1	3000	5.5	700	-200	190	73	42	1x...4740/...4840		
	3600	6.3	840	-180	180	75				
	4200	7.5	980	-110	90	78				
	5000	8.8	1140	-10	10	84				
2	3000	7.5	700	-270	260	73				
	3600	8.6	840	-270	260	75				
	4200	10.0	980	-250	220	78				
	5000	12.0	1140	-240	180	84				

Vacuum Selection diagram —真空选型图表

Compressor Celetion Diagram —压缩选型图表

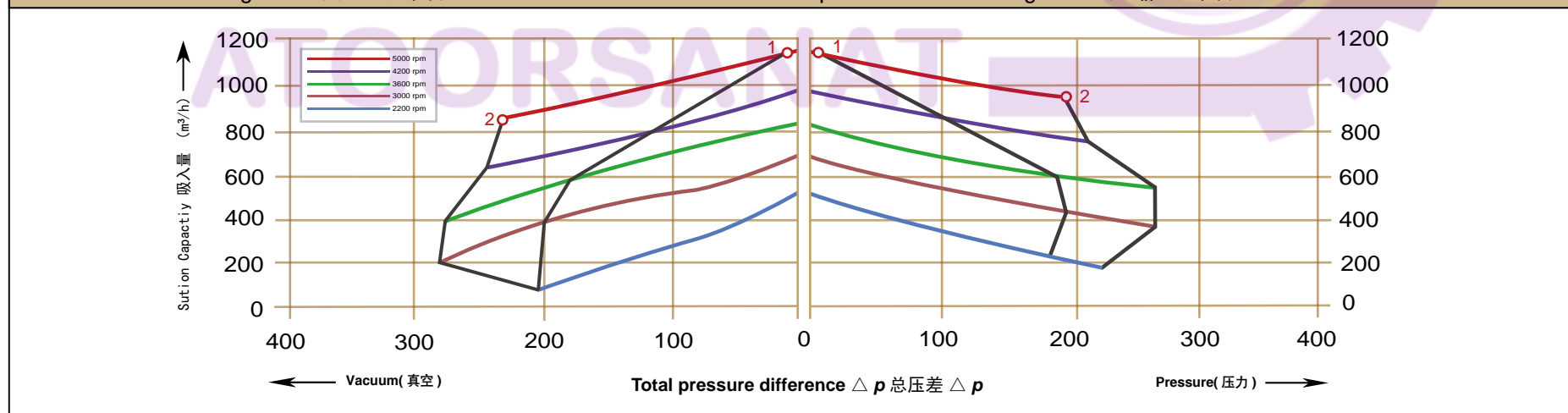

2RB 913-1HY99 Ordering data

2RB 913-1HY99 订购参数



下面的性能曲线是在抽吸 15°C 空气，排气压力 1013mbar 的工况下测出的，允差 ±10%，吸入空气和环境温度不超过 25°C 时，即可达到图示总压差。

The performance curves are valid for pumping air at 15°C at the inlet flanges with an air pressure of 1.013mbar and a tolerance of ±10%. The total pressure differences are valid up to an intake and ambient temperature of 25°C.

NO	Rated Speed	Rated power	Maximim Air flow	Maximim vacuum	maximim pressure	Sound-level	Weight approx	Vacuum rellet
编号	转速	配置功率	最大流量	最大真空	最大压力	噪音	重量	Items×type
	RPM	KW	m³/h	mbar	mbar	dB(A)	Kg	2BX
1	3000	8.5	1050	-190	190	74	72	1x...750/...860
	3600	9.8	1250	-150	140	79		
	4200	12.0	1400	-60	80	82		
2	3000	12.5	1050	-290	280	74		
	3600	14.5	1250	-270	260	79		
	4200	17.5	1400	-250	240	82		
3	3000	18.5	1050	-360	460	74		
	3600	21.3	1250	-380	420	79		
	4200	26.0	1400	-400	400	82		

Vacuum Selection diagram —真空选型图表

Compressor Celetion Diagram —压缩选型图表

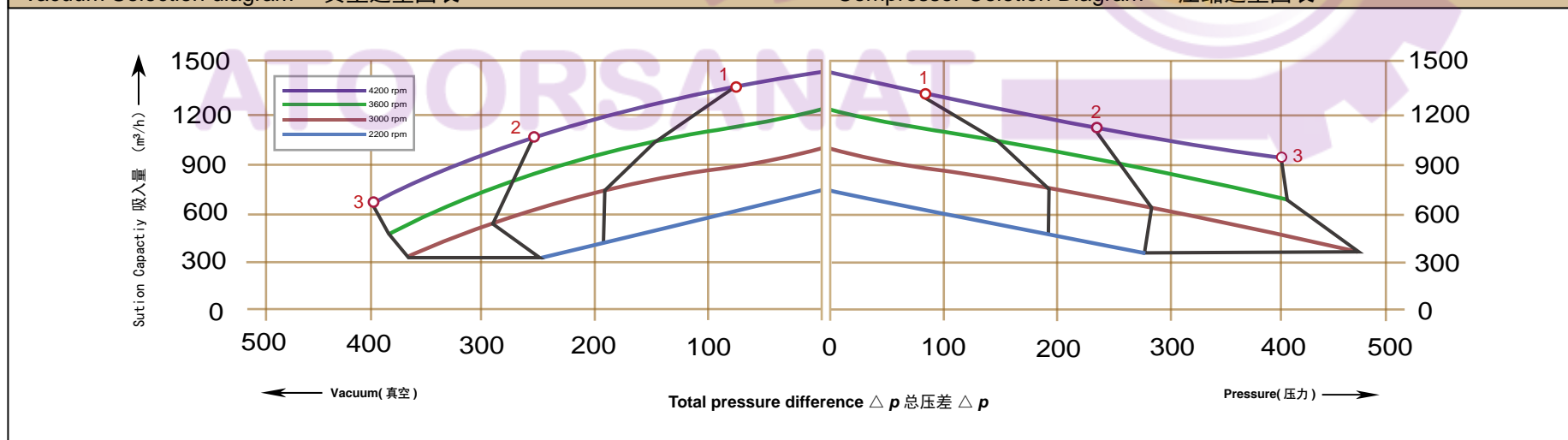

2RB 923-1HY99 Ordering data

2RB 923-1HY99 订购参数



下面的性能曲线是在抽吸 15°C 空气，排气压力 1013mbar 的工况下测出的，允差 ±10%，吸入空气和环境温度不超过 25°C 时，即可达到图示总压差。

The performance curves are valid for pumping air at 15°C at the inlet flanges with an air pressure of 1.013mbar and a tolerance of ±10%. The total pressure differences are valid up to an intake and ambient temperature of 25°C .

NO	Rated Speed	Rated power	Maximim Air flow	Maximim vacuum	maximim pressure	Sound-level	Weight approx	Vacuum rellet
编号	转速	配置功率	最大流量	最大真空	最大压力	噪音	重量	Items × type
	RPM	KW	m³/h	mbar	mbar	dB(A)	Kg	2BX
1	3000	12.5	1110	-300	270	74	110	2x...750/...860
	3600	14.5	1310	-220	200	84		
	4200	17.5	1600	-150	130	87		
2	3000	16.5	1110	-410	370	74		
	3600	19.0	1310	-340	300	84		
	4200	21.0	1600	-270	240	87		
3	3000	20.0	1110	-440	500	74		
	3600	23.0	1310	-440	430	84		
	4200	28.0	1600	-440	340	87		
4	3000	25.0	1110	-440	590	74		
	3600	29.0	1310	-440	540	84		
	4200	35.0	1600	-460	460	87		

Vacuum Selection diagram — 真空选型图表

Compressor Celetion Diagram — 压缩选型图表

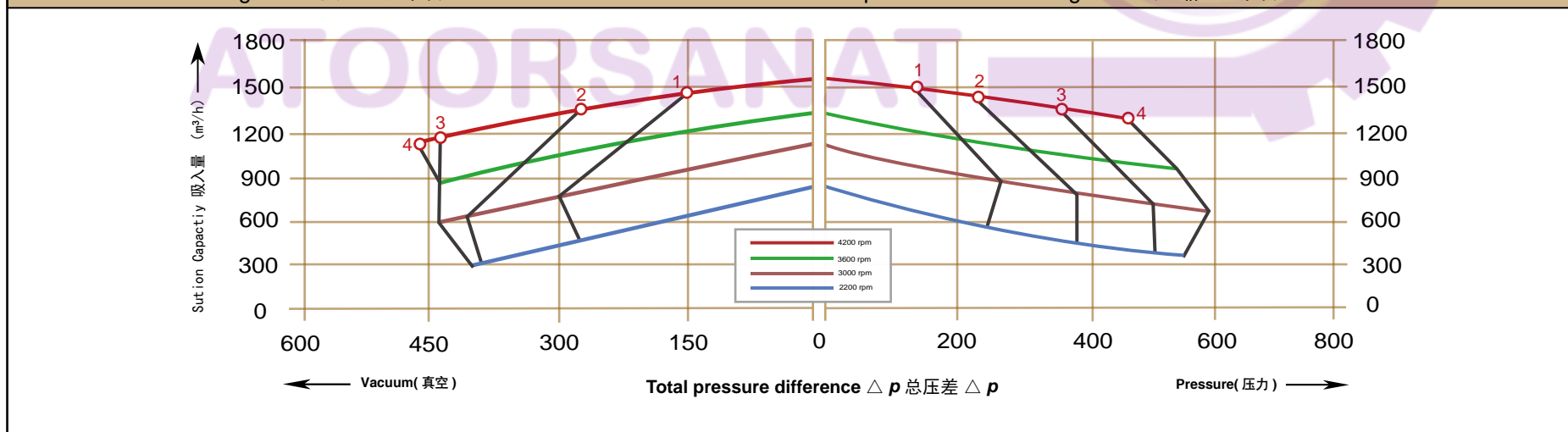

2RB 933-1HY99 Ordering data

2RB 933-1HY99 订购参数



下面的性能曲线是在抽吸 15°C 空气，排气压力 1013mbar 的工况下测出的，允差 ±10%，吸入空气和环境温度不超过 25°C 时，即可达到图示总压差。

The performance curves are valid for pumping air at 15°C at the inlet flanges with an air pressure of 1.013mbar and a tolerance of ±10%. The total pressure differences are valid up to an intake and ambient temperature of 25°C .

NO	Rated Speed	Rated power	Maximim Air flow	Maximim vacuum	maximim pressure	Sound-level	Weight approx	Vacuum rellet
编号	转速	配置功率	最大流量	最大真空	最大压力	噪音	重量	Items×type
	RPM	KW	m³/h	mbar	mbar	dB(A)	Kg	2BX
1	3000	12.5	1370	-190	190	75	76	2x...750/...860
	3600	14.5	1600	-150	150	80		
	4200	17.5	1850	-130	120	82		
2	3000	15.0	1370	-280	260	75		
	3600	17.5	1600	-240	220	80		
	4200	21.6	1850	-210	190	82		
3	3000	18.5	1370	-310	320	75		
	3600	21.3	1600	-300	280	80		
	4200	26.0	1850	-260	250	82		

Vacuum Selection diagram —真空选型图表

Compressor Celetion Diagram —压缩选型图表

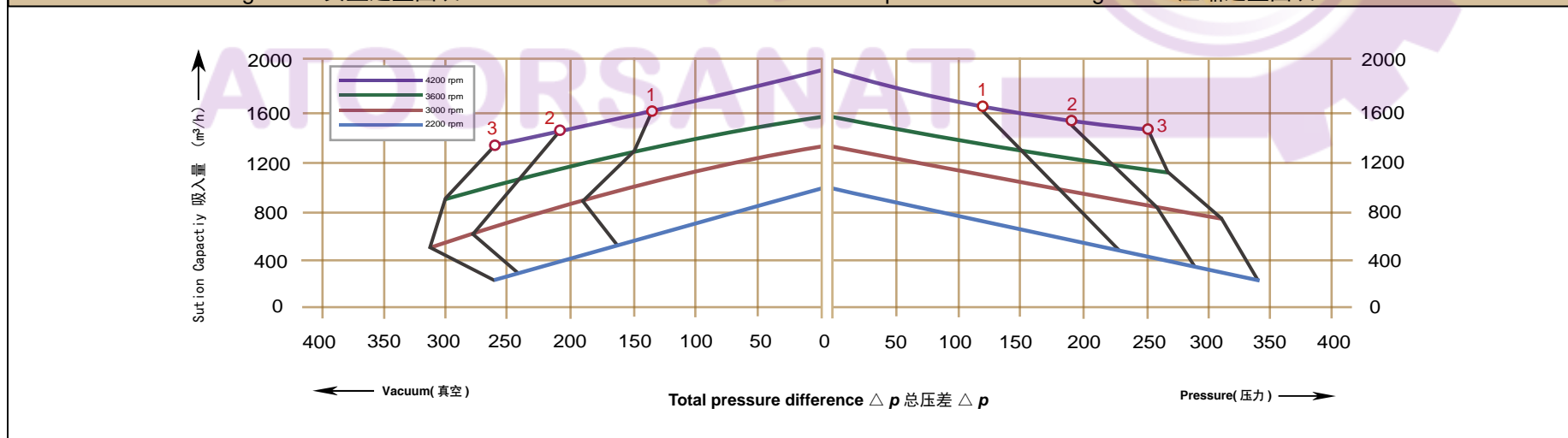

2RB 943-1HY99 Ordering data

2RB 943-1HY99 订购参数



下面的性能曲线是在抽吸 15°C 空气，排气压力 1013mbar 的工况下测出的，允差 ±10%，吸入空气和环境温度不超过 25°C 时，即可达到图示总压差。

The performance curves are valid for pumping air at 15°C at the inlet flanges with an air pressure of 1.013mbar and a tolerance of ±10%. The total pressure differences are valid up to an intake and ambient temperature of 25°C .

NO	Rated Speed	Rated power	Maximim Air flow	Maximim vacuum	maximim pressure	Sound-level	Weight approx	Vacuum rellet
编号	转速	配置功率	最大流量	最大真空	最大压力	噪音	重量	Itemsxtype
	RPM	KW	m³/h	mbar	mbar	dB(A)	Kg	2BX
1	3000	20.0	1940	-220	200	75	118	2x...750/...860
	3600	23.0	2300	-160	130	84		
	4200	28.0	2700	-90	80	87		
2	3000	25.0	1940	-300	300	75		
	3600	29.0	2300	-280	250	84		
	4200	35.0	2700	-200	150	87		

Vacuum Selection diagram — 真空选型图表

Compressor Celetion Diagram — 压缩选型图表

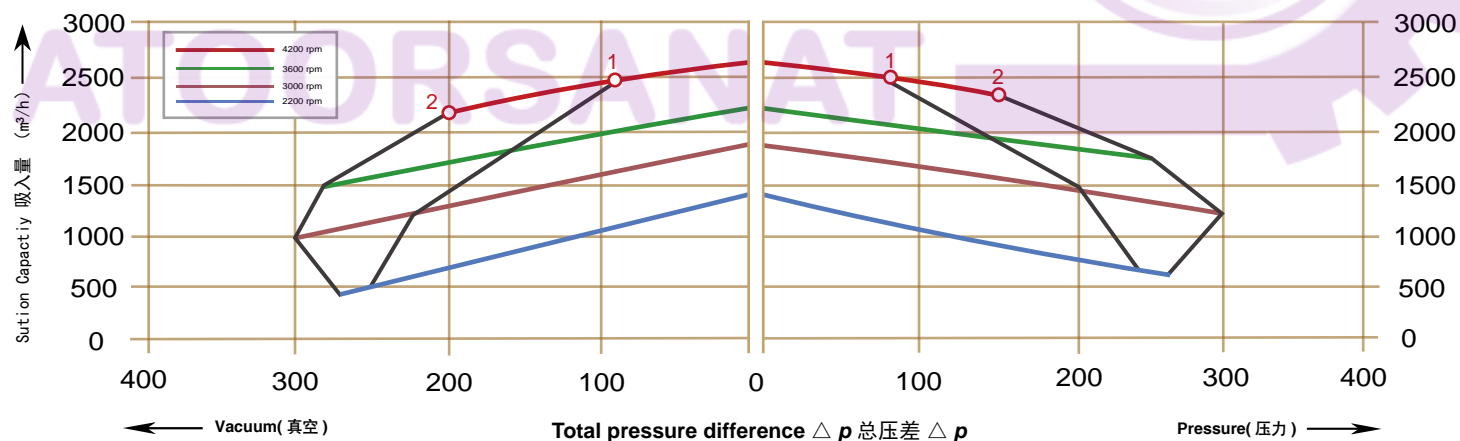

G-400 单级和双级

G-400 Single and double stage

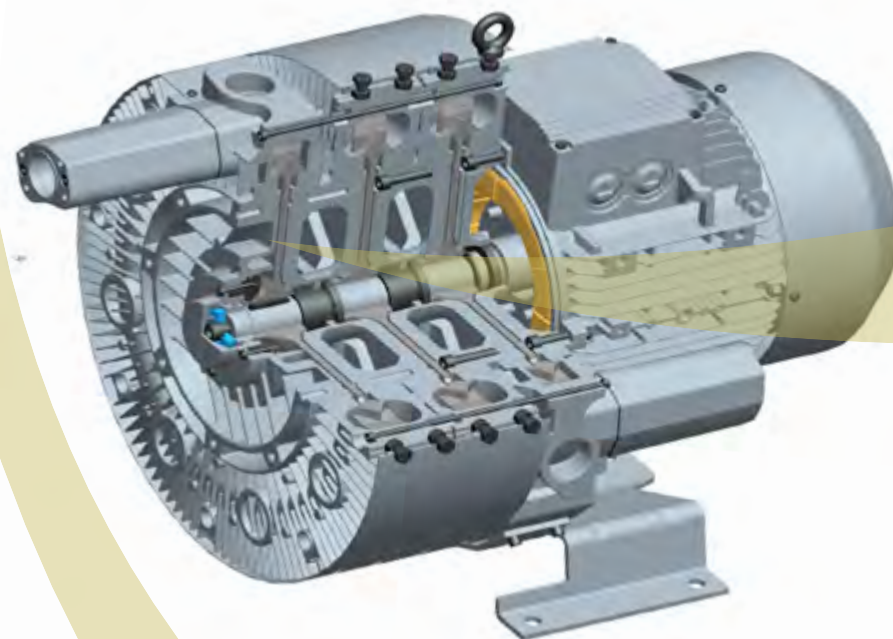
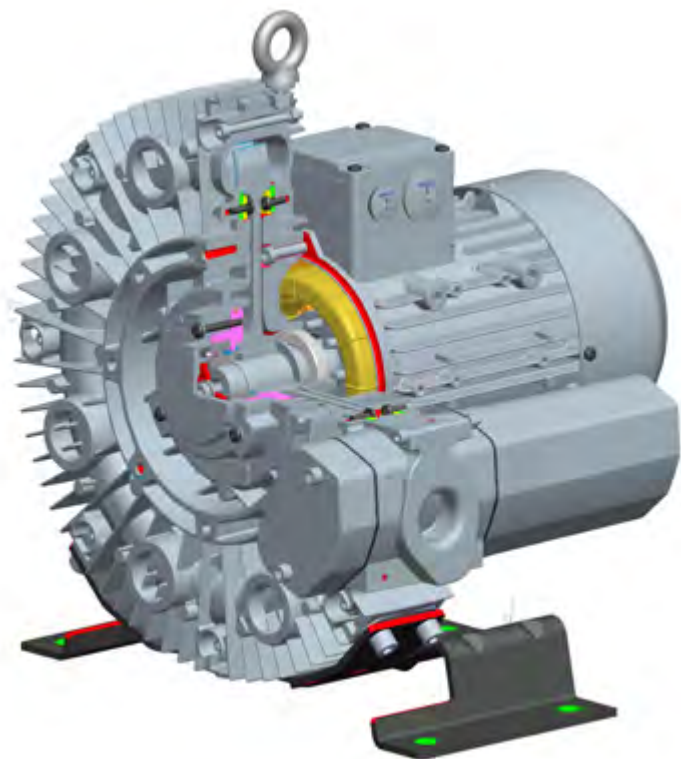

最高压差的巅峰之作 UNSURPASSED AT HIGHEST DIFFERENTIAL PRESSURE

我们富有革命性的 G_400 压缩机能产生高达 1,000mbar 的压差——远远高于其它任何的气环式压缩机。截止目前，能产生此压差范围的其它系统要比我们的 G_400 体积更庞大，噪音更高，而且容易磨损。现在，除了拥有低噪声、无磨损这些优点外，我们的 G_400 还能在更为苛刻的条件下应用。

G_400 真空泵 / 压缩机能在不停机维护的条件下连续工作 20,000 小时。

它们卓越的安全可靠性即便是在最苛刻的工作条件下也得到了证实，虽然它们的低噪音已给人们留下了很深刻的印象，但我们的工程师和设计者们还能使它们变得更加安静。

G_400 选型图表，真空抽吸和压缩模式，50Hz/60Hz
有关电压，脚注等详细信息请参看

第 49-54 页
第 72 页

Our revolutionary G_400 blower can create pressure difference of up to 1000mbar-more than any other gas ring pump. So far, the systems used to reach these differential pressure ranges were much louder and larger-or subject to wear. Now the advantage of wear-free operation coupled with a low noise level can also be used in most demanding applications.

The G_400 series side channel vacuum pump/compressor can work up to 20,000 hours without maintenance down time.

These specialist machines have proven their reliability under the harshest of conditions. Their noise level was already impressively low, but our engineers and designers are able to make them even more quiet.

Selection diagrams and tables for G_400
Vacuum and pressure mode, 50Hz and 60Hz
Details on voltages, footnotes etc see

Pages 49-54

Page 72

4RB 1AC

G 系列 · G-Series

漩涡式气泵在真空和压力操作的选型和订购参数（单相）

Selection and ordering data for side channel blowers in vacuum and pressure operation(Single phase)

订购型号	马 达				重量	噪音	最大流量	最高真空	最高压力	真空阀
· 有库存	输出功率	额 定		类型 × 型号						
			电 压		电 流					
Order No.	MOTOR				Weight approx	Sound-Pressure level	Maximum airflow	Maximum vacuum	Maximum pressure	Vacuum relief valve
· available ex stock	Fre-quency	Rated								Items × type
		output	voltage	current						
	HZ	KW	V	A	KG	dB(A)	m³/h	mbar	mbar	
· 4RB 210-0AV75-7	50	0.55	115/230	13/3.1	18	57	47	-230	290	1x...2110/...2141
	60	0.63	115/230	14.2/7.1		62	57	-270	320	1x...2114/...2142
· 4RB 220-0AV75-7	50	1.5	115/230	19.4/9.7	30	58	47	-370	600	1x...2110/...2141
	60	1.75	115/230	20.6/10.3		62	60	-420	660	1x...2114/...2142
· 4RB 310-0AV71-7	50	0.94	230	9	18	57	66	-250	350	1x...2110/...2141
· 4RB 310-0AV75-7	50	0.94	115/230	15.2/7.6	18	57	66	-250	350	1x...2110/...2141
	60	1.1	115/230	18/9		62	80	-280	390	1x...2114/...2142
· 4RB 320-0AV75-7	50	1.5	115/230	19.4/9.7	32	59	65	-400	550	1x...2110/...2141
	60	1.75	115/230	20.6/10.3		63	76	-390	540	1x...2114/...2142
· 4RB 410-0AA41-7	50	1.1	230	10.1	23	58	87	-300	380	1x...2110/...2141
	60	1.3	230	10.3	23	63	105	-350	390	1x...2114/...2142

4RB Series Selection diagram 50/60Hz 1AC

4RB 系列 50/60Hz 选型图表 1AC



下面的性能曲线是在抽吸 15°C 空气，排气压力 1013mbar 的工况下测出的，允差 ±10%，吸入空气和环境温度不超过 25°C 时，即可达到图示总压差。

The performance curves are valid for pumping air at 15°C at the inlet flanges with an air pressure of 1.013mbar and a tolerance of ±10%. The total pressure differences are valid up to an intake and ambient temperature of 25°C .

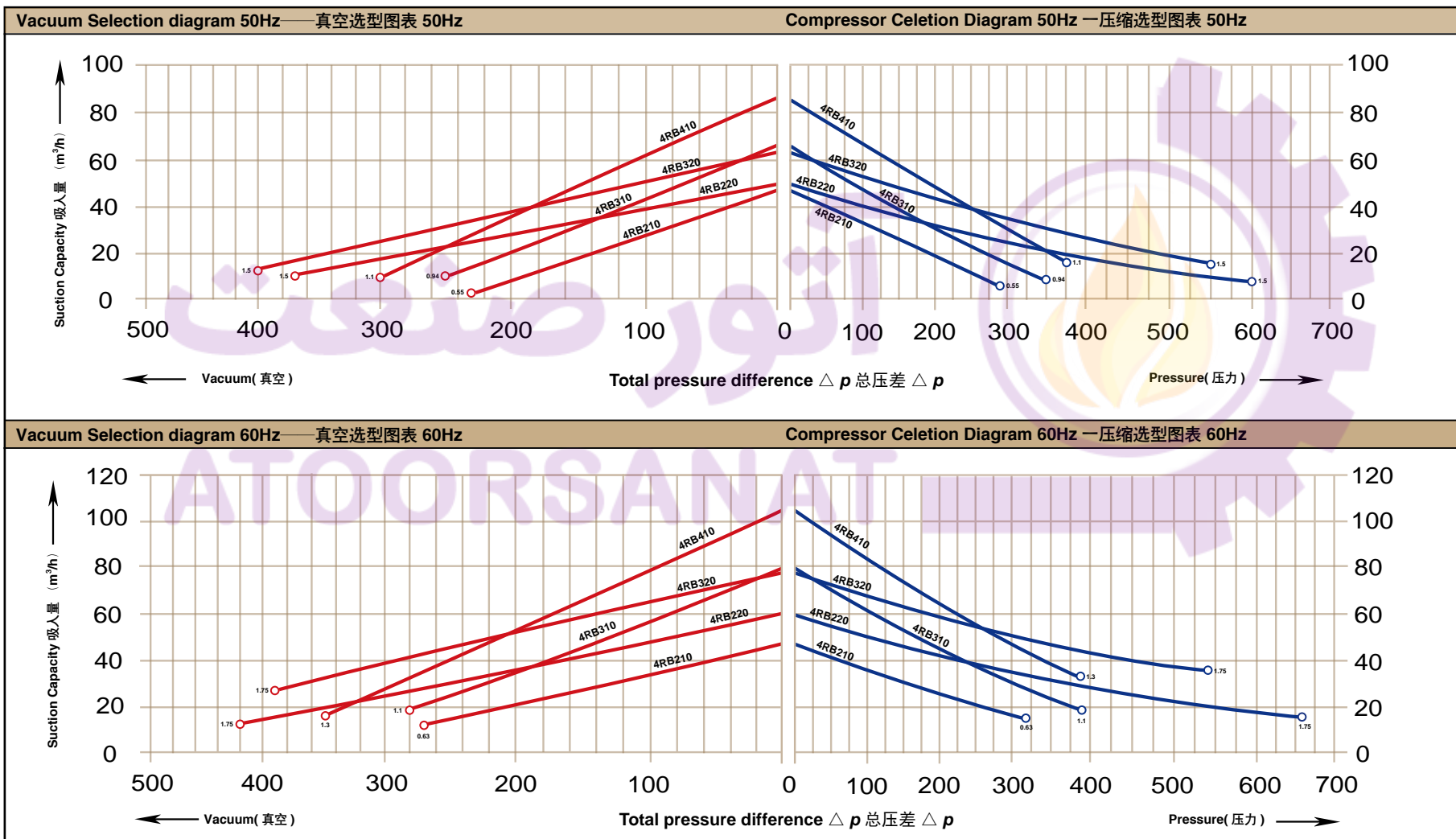

G-400

4RB 3AC

G 系列 · G-Series

漩涡式气泵在真空和压力操作的选型和订购参数（三相、单级）

Selection and ordering data for side channel blowers in vacuum and pressure operation(Three phase single stage)

订购型号	马 达			重量	噪音	最大流量	最高真空	最高压力	真空阀	
· 有库存	额 定		类型 × 型号							
	输出功率	电 压	电 流							
Order No.	MOTOR			Weight approx	Sound-Pressure level	Maximum airflow	Maximum vacuum	Maximum pressure	Vacuum relief valve	
· available ex stock	Fre-quency	Rated							Items × type	
		output	voltage	current						
	HZ	KW	V	A	KG	dB(A)	m³/h	mbar	mbar	
· 4RB 210-0AH16-7	50	0.55	200-240 △ /345-415	2.8 △ /1.6Y	16	57	47	-230	290	1x...2110/...2141
	60	0.63	220-275 △ /380-480	3 △ /1.7Y		62	57	-270	320	1x...2114/...2142
· 4RB 310-0AH16-7	50	0.55	200-240 △ /345-415	2.8 △ /1.6Y	16	57	66	-250	250	1x...2110/...2141
	60	0.63	220-275 △ /380-480	3 △ /1.7Y		62	80	-260	250	1x...2114/...2142
· 4RB 310-0AH26-7	50	0.81	200-240 △ /345-415	4 △ /2.3Y	17	57	66	-280	350	1x...2110/...2141
	60	0.94	220-275 △ /380-480	4 △ /2.3Y		62	80	-340	360	1x...2114/...2142
· 4RB 410-0AH16-7	50	1.1	200-240 △ /345-415	5.4 △ /3.1Y	23	58	87	-300	380	1x...2110/...2141
	60	1.3	220-275 △ /380-480	5.4 △ /3.1Y		62	105	-340	370	1x...2114/...2142
· 4RB 510-0AH16-8	50	1.5	200-240 △ /345-415	7.5 △ /4.3Y	26	64	120	-310	360	1x...2110/...2141
	60	1.75	220-275 △ /380-480	7.6 △ /4.4Y		68	145	-340	320	1x...2114/...2142
· 4RB 510-0AH26-8	50	2.2	345-415 △ /600-720	11.4 △ /6.6Y	29	64	120	-310	470	1x...2110/...2141
	60	2.55	380-480 △ /660-720	11.2 △ /6.5Y		68	145	-360	480	1x...2114/...2142
· 4RB 610-0AH16-8	50	2.2	200-240 △ /345-415	11.4 △ /6.6Y	32	65	165	-340	360	1x...2110/...2141
	60	2.55	220-275 △ /380-480	11.2 △ /6.5Y		71	195	-360	315	1x...2114/...2142
· 4RB 610-0AH36-8	50	3.3	200-240 △ /345-415	13 △ /7.5Y	35	65	165	-340	480	1x...2110/...2141
	60	3.8	220-275 △ /380-480	14.2 △ /8.2Y		71	195	-380	530	1x...2114/...2142

4RB Series Selection diagram 50/60Hz 3AC

4RB 系列 50/60Hz 选型图表 3AC



下面的性能曲线是在抽吸 15°C 空气，排气压力 1013mbar 的工况下测出的，允差 ±10%，吸入空气和环境温度不超过 25°C 时，即可达到图示总压差。

The performance curves are valid for pumping air at 15°C at the inlet flanges with an air pressure of 1.013mbar and a tolerance of ±10%. The total pressure differences are valid up to an intake and ambient temperature of 25°C .

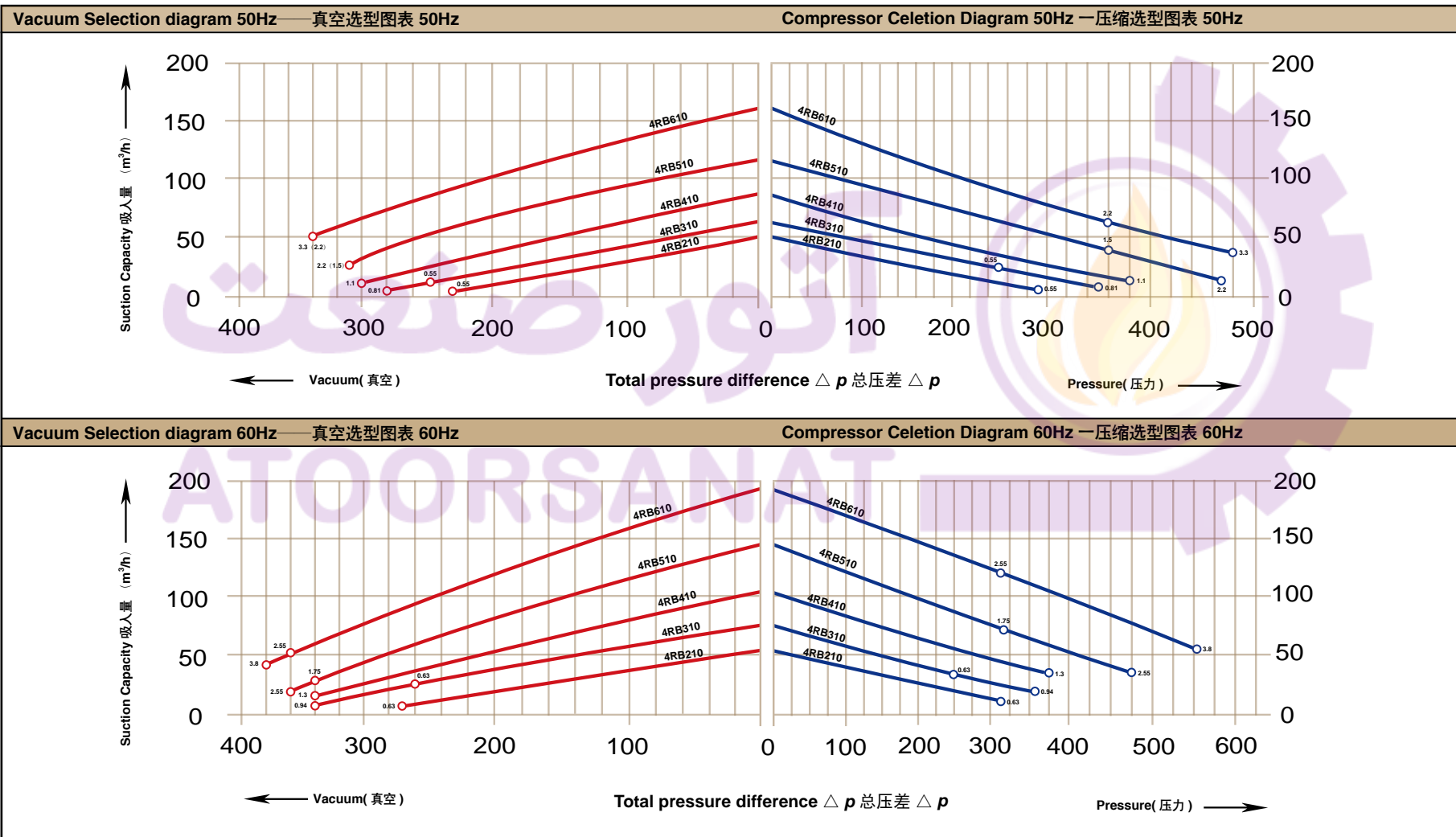

G-400

4RB 3AC

G 系列 · G-Series

漩涡式气泵在真空和压力操作的选型和订购参数（多级）

Selection and ordering data for side channel blowers in vacuum and pressure operation(Multi-stage)

订购型号	马 达				重量	噪音	最大流量	最高真空	最高压力	真空阀
	· 有库存	额 定								类型 × 型号
		输出功率	电 压	电 流						
Order No.	MOTOR				Weight approx	Sound-Pressure level	Maximum airflow	Maximum vacuum	Maximum pressure	Vacuum relief valve
· available ex stock	Fre-quency	Rated								Items × type
		output	voltage	current						
	HZ	KW	V	A	KG	dB(A)	m³/h	mbar	mbar	
· 4RB 220-0AH26-7	50	0.81	200-240 △ /345-415	4 △ /2.3Y	24	58	47	-370	490	1x...2110/...2141
	60	0.94	220-275 △ /380-480	4 △ /2.3Y		62	60	-440	480	1x...2114/...2142
· 4RB 220-0AH56-7	50	1.5	200-240 △ /345-415	7.5 △ /4.3Y	28	58	47	-370	650	1x...2110/...2141
	60	1.75	220-275 △ /380-480	7.6 △ /4.4Y		62	60	-500	740	1x...2114/...2142
· 4RB 320-0AH46-7	50	1.1	200-240 △ /345-415	5.4 △ /3.1Y	29	59	65	-400	480	1x...2110/...2141
	60	1.3	220-275 △ /380-480	5.4 △ /3.1Y		63	76	-480	480	1x...2114/...2142
· 4RB 320-0AH56-7	50	1.5	200-240 △ /345-415	7.5 △ /4.3Y	30	59	65	-440	540	1x...2110/...2141
	60	1.75	220-275 △ /380-480	7.5 △ /4.4Y		63	76	-560	600	1x...2114/...2142
· 4RB 420-0AH26-7	50	1.5	200-240 △ /345-415	7.5 △ /4.3Y	33	61	87	-480	450	1x...2110/...2141
	60	1.75	220-275 △ /380-480	7.6 △ /4.4Y		66	105	-430	410	1x...2114/...2142
· 4RB 420-0AH56-7	50	3.3	200-240 △ /345-415	13 △ /7.5Y	39	61	87	-500	750	1x...2110/...2141
	60	3.8	220-275 △ /380-480	13.8 △ /8Y		66	105	-510	850	1x...2114/...2142
· 4RB 520-0AH26-8	50	2.2	200-240 △ /345-415	11.4 △ /6.6Y	40	64	120	-470	460	1x...2110/...2141
	60	2.55	220-275 △ /380-480	11.2 △ /6.5Y		70	145	-500	450	1x...2114/...2142
· 4RB 520-0AH77-8	50	4	345-415 △	9 △	51	65	120	-500	820	1x...2110/...2141
	60	4.6	380-480 △	9.5 △		71	145	-530	810	1x...2114/...2142
· 4RB 620-0AH36-8	50	3.3	200-240 △ /345-415	13 △ /7.5Y	48	67	165	-460	500	1x...2110/...2141
	60	3.8	220-275 △ /380-480	14.2 △ /8.2Y		71	195	-480	420	1x...2114/...2142
· 4RB 620-0AH57-8	50	5.7	345-415 △	12.5 △	65	68	165	-460	740	1x...2110/...2141
	60	6.6	380-480 △	12 △		72	195	-480	840	1x...2114/...2142
· 4RB 630-0AH67-8	50	7.5	345-415 △	16 △	86	72	170	-730	1040	1x...2110/...2141
	60	8.6	380-480 △	16 △		76	200	-700	1040	1x...2114/...2142



下面的性能曲线是在抽吸 15°C 空气，排气压力 1013mbar 的工况下测出的，允差 ±10%，吸入空气和环境温度不超过 25°C 时，即可达到图示总压差。

The performance curves are valid for pumping air at 15 °C at the inlet flanges with an air pressure of 1.013mbar and a tolerance of ±10%. The total pressure differences are valid up to an intake and ambient temperature of 25 °C .

Vacuum Selection diagram 50Hz — 真空选型图表 50Hz Compressor Selection Diagram 50Hz — 压缩选型图表 50Hz

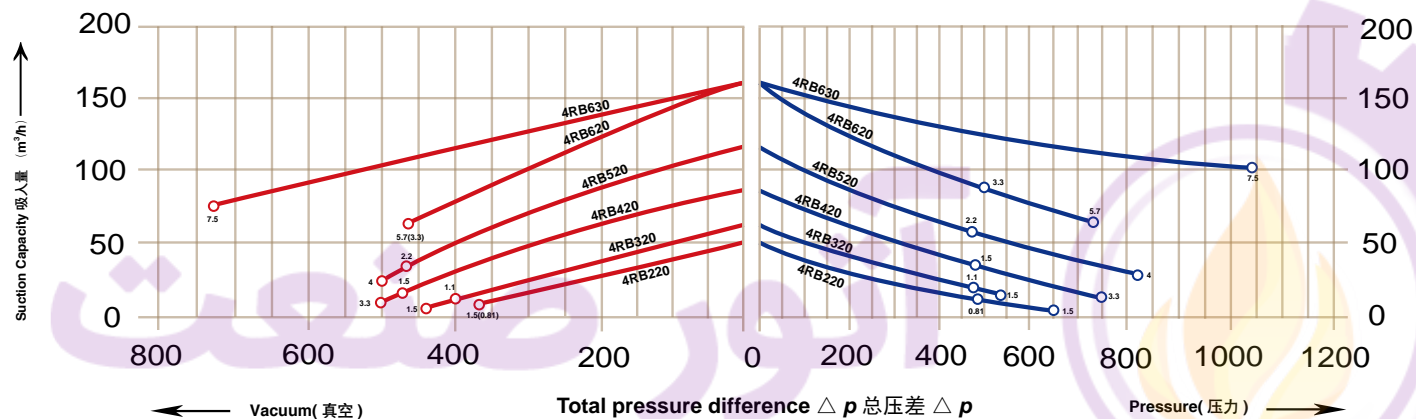

Vacuum Selection diagram 60Hz — 真空选型图表 60Hz Compressor Selection Diagram 60Hz — 压缩选型图表 60Hz

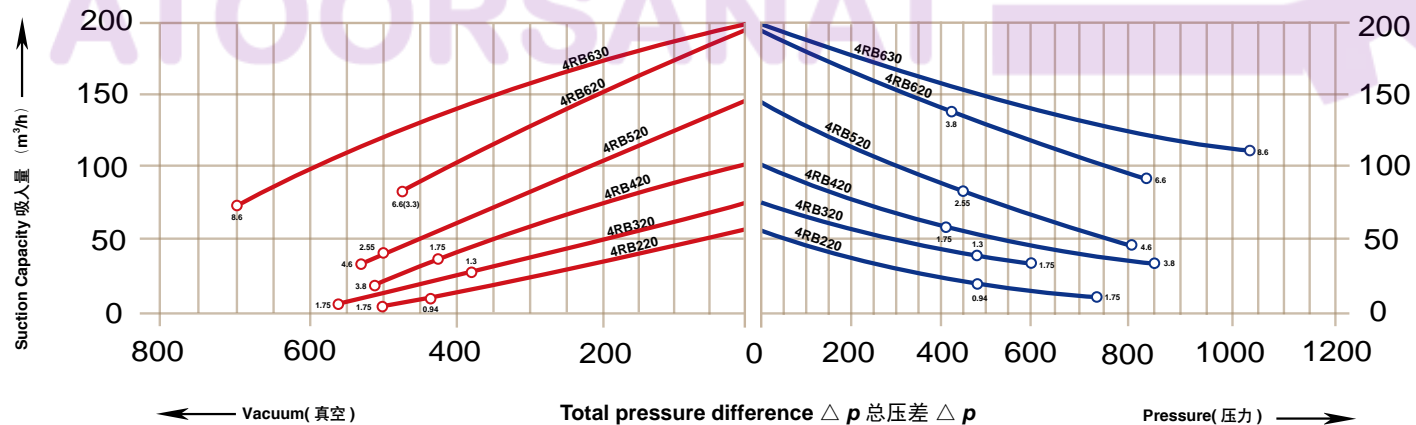

G-400

Dimensions for side channel blower 2RB210.,2RB230.,2RB330(mm)
侧风道风机尺寸 2RB210.,2RB310.,2RB330.(mm)

2RB210./2RB230./2RB310./2RB330

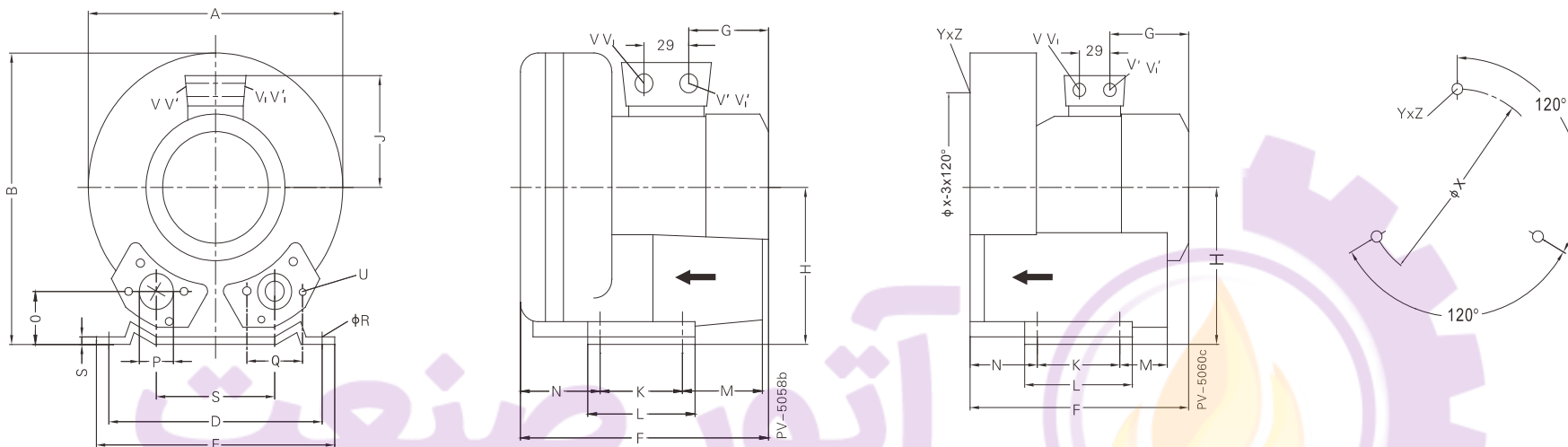

Type 型号	Phases 相位	A	B	C	D	E	F	G	H	J	K	L	M	N	O	P	Q	φR	S	U	V _{1(a)}	V _{1(b)}	V _{1(c)}	V _{1(d)}	Y×Z	X-Holes	φx
2RB 210-7AH06	3~	246	247	90	205	230	219	92	128	111	83	108	75	71	39	G _{1.6} (15tie • deep)	64	10	2.5	M6×17	-	-	M25×1.5	M16×1.5	M6×15	0°/120°/240°	140
2RB 210-7AV15	1~	246	247	90	205	230	256	135	128	111	83	108	75	71	39	G _{1.6} (15tie • deep)	64	10	2.5	M6×17	M16×1.5	M25×1.5	-	-	M6×15	0°/120°/240°	140
2RB 210-7AH16	3~	246	247	90	205	230	256	135	128	111	83	108	75	71	39	G _{1.6} (15tie • deep)	64	10	2.5	M6×17	-	-	M25×1.5	M16×1.5	M6×15	0°/120°/240°	140
2RB 210-7AA11	1~	246	247	90	205	230	256	135	128	111	83	108	75	71	39	G _{1.6} (15tie • deep)	64	10	2.5	M6×17	M16×1.5	M25×1.5	-	-	M6×15	0°/120°/240°	140
2RB 230-7AH06	3~	246	247	90	205	230	242	102	128	101	83	108	75	82	39	G _{1.6} (15tie • deep)	64	10	2.5	M6×17	-	-	M25×1.5	M16×1.5	M6×15	0°/120°/240°	140
2RB 230-7AH16	3~	246	247	90	205	230	267	135	128	111	83	108	75	82	39	G _{1.6} (15tie • deep)	64	10	2.5	M6×17	-	-	M25×1.5	M16×1.5	M6×15	0°/120°/240°	140
2RB 230-7AH26	3~	246	247	90	205	230	267	135	128	111	83	108	75	82	39	G _{1.6} (15tie • deep)	64	10	2.5	M6×17	-	-	M25×1.5	M16×1.5	M6×15	0°/120°/240°	140
2RB 230-7AV15	1~	246	247	90	205	230	267	135	128	111	83	108	75	82	39	G _{1.6} (15tie • deep)	64	10	2.5	M6×17	M16×1.5	M25×1.5	-	-	M6×15	0°/120°/240°	140
2RB 230-7AA11	1~	246	247	90	205	230	267	135	128	111	83	108	75	82	39	G _{1.6} (15tie • deep)	64	10	2.5	M6×17	M16×1.5	M25×1.5	-	-	M6×15	0°/120°/240°	140
2RB 310-7AH06	3~	268	272	93	205	230	260	135	141	111	83	108	82	69	41	G _{1.6} (15tie • deep)	64	10	2.5	M6×17	-	-	M25×1.5	M16×1.5	M6×15	0°/120°/240°	160
2RB 310-7AH16	3~	268	272	93	205	230	260	135	141	111	83	108	82	69	41	G _{1.6} (15tie • deep)	64	10	2.5	M6×17	-	-	-	-	M6×15	0°/120°/240°	160
2RB 310-7AA01	1~	268	272	93	205	230	260	135	141	111	83	108	82	69	41	G _{1.6} (15tie • deep)	64	10	2.5	M6×17	M16×1.5	M25×1.5	-	-	M6×15	0°/120°/240°	160
2RB 310-7AA11	1~	268	272	93	205	230	260	135	141	111	83	108	82	69	41	G _{1.6} (15tie • deep)	64	10	2.5	M6×17	M16×1.5	M25×1.5	-	-	M6×15	0°/120°/240°	160
2RB 330-7AH06	3~	268	272	93	205	230	276	135	141	111	83	108	82	85	41	G _{1.6} (15tie • deep)	64	10	2.5	M6×17	-	-	M25×1.5	M16×1.5	M6×15	0°/120°/240°	160
2RB 330-7AH16	3~	268	272	93	205	230	276	135	141	111	83	108	82	85	41	G _{1.6} (15tie • deep)	64	10	2.5	M6×17	-	-	M25×1.5	M16×1.5	M6×15	0°/120°/240°	160
2RB 330-7AA11	1~	268	272	93	205	230	276	135	141	111	83	108	82	85	41	G _{1.6} (15tie • deep)	64	10	2.5	M6×17	M16×1.5	M25×1.5	-	-	M6×15	0°/120°/240°	160

Dimensions for side channel blower 2RB410.,2RB430.,2RB490(mm)

侧风道风机尺寸 2RB410.,2RB430.,2RB490(mm)

2RB 410./2RB430./2RB490.

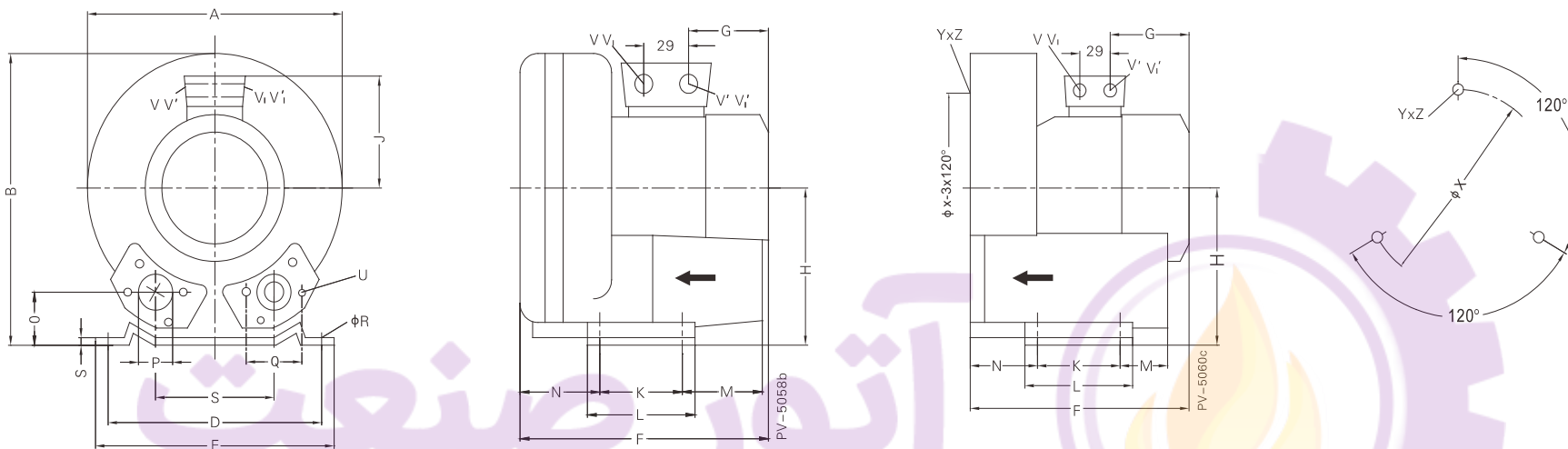

Type	Phases	A	B	C	D	E	F	G	H	J	K	L	M	N	O	P	Q	φR	S	U	V ₁₍₁₋₎	V ₁₍₁₋₎	V ₁₍₃₋₎	V ₁₍₃₋₎	Y×Z	X-Holes	φx
型号	相位																										
2RB410-7AA11	1 ~	286	302	115	225	225	294	156	154	120	95	130	70	75	46	G _{1,2} (15tie • deep)	72	12	3	M6×19	M16×1.5	M25×1.5	—	—	M6×15	0°/120°/240°	174
2RB410-7AA21	1 ~	286	302	115	225	225	294	156	154	120	95	130	70	75	46	G _{1,2} (15tie • deep)	72	12	3	M6×19	M16×1.5	M25×1.5	—	—	M6×15	0°/120°/240°	174
2RB410-7AV25	1 ~	286	302	115	225	225	294	156	154	120	95	130	70	75	46	G _{1,2} (15tie • deep)	72	12	3	M6×19	M16×1.5	M25×1.5	—	—	M6×15	0°/120°/240°	174
2RB410-7AH06	3 ~	286	302	115	225	225	269	129	154	111	95	130	70	75	46	G _{1,2} (15tie • deep)	72	12	3	M6×19	—	—	M25×1.5	M16×1.5	M6×15	0°/120°/240°	174
2RB410-7AH16	3 ~	286	302	115	225	255	292	156	154	120	95	130	70	75	46	G _{1,2} (15tie • deep)	72	12	3	M6×19	—	—	M25×1.5	M16×1.5	M6×15	0°/120°/240°	174
2RB410-7AH26	3 ~	286	302	115	225	255	292	156	154	120	95	130	70	75	46	G _{1,2} (15tie • deep)	72	12	3	M6×19	—	—	M25×1.5	M16×1.5	M6×15	0°/120°/240°	174
2RB 430-7AA11	1 ~	286	302	115	225	255	311	156	154	120	95	130	70	75	46	G _{1,2} (15tie • deep)	72	12	3	M6×19	M16×1.5	M25×1.5	—	—	M6×15	0°/120°/240°	174
2RB 430-7AA21	1 ~	286	302	115	225	255	311	156	154	120	95	130	70	75	46	G _{1,2} (15tie • deep)	72	12	3	M6×19	M16×1.5	M25×1.5	—	—	M6×15	0°/120°/240°	174
2RB 430-7AH06	3 ~	286	302	115	225	255	288	129	154	111	95	130	70	75	46	G _{1,2} (15tie • deep)	72	12	3	M6×19	—	—	M25×1.5	M16×1.5	M6×15	0°/120°/240°	174
2RB 430-7AH16	3 ~	286	302	115	225	255	311	156	154	120	95	130	70	75	46	G _{1,2} (15tie • deep)	72	12	3	M6×19	—	—	M25×1.5	M16×1.5	M6×15	0°/120°/240°	174
2RB 430-7AH26	3 ~	286	302	115	225	255	311	156	154	120	95	130	70	75	46	G _{1,2} (15tie • deep)	72	12	3	M6×19	—	—	M25×1.5	M16×1.5	M6×15	0°/120°/240°	174
2RB 430-7AV25	1 ~	286	302	115	225	255	311	156	154	120	95	130	70	75	46	G _{1,2} (15tie • deep)	72	12	3	M6×19	M16×1.5	M25×1.5	—	—	M6×15	0°/120°/240°	174
2RB 490-7AV25	1 ~	286	302	115	225	255	311	156	154	120	95	130	70	75	46	G _{1,2} (15tie • deep)	72	12	3	M6×19	M16×1.5	M25×1.5	—	—	M6×15	0°/120°/240°	174
2RB 490-7AH16	3 ~	286	302	115	225	255	311	156	154	120	95	130	70	75	46	G _{1,2} (15tie • deep)	72	12	3	M6×19	—	—	M25×1.5	M16×1.5	M6×15	0°/120°/240°	174

Dimensions for side channel blower 2RB510.,2RB530.,2RB590(mm)
侧风道风机尺寸 2RB220.,2RB320.,2RB420.(mm)

2RB220./2RB320./2RB420

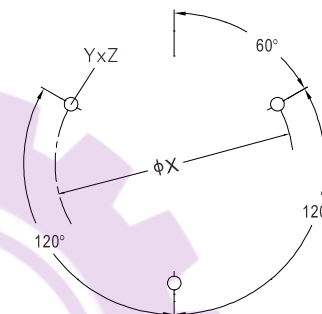
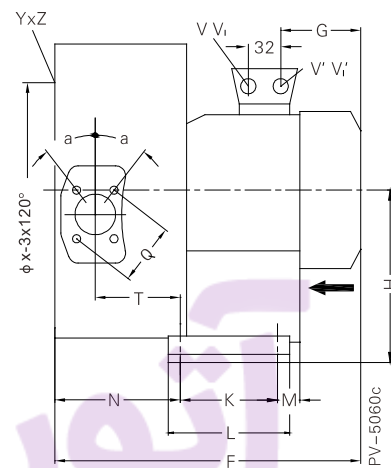
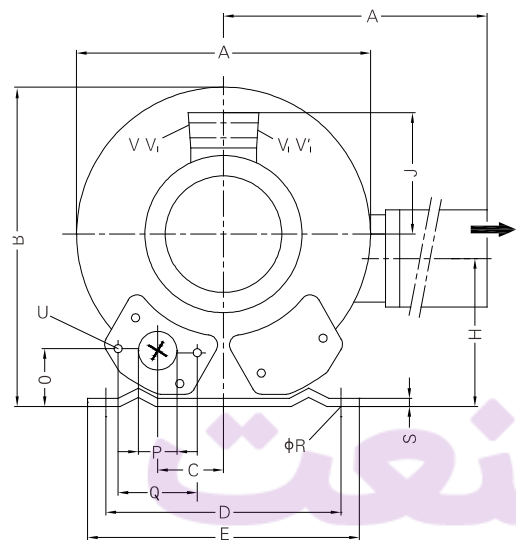

Type	Phases	A	A'	B	C	D	E	F	G	H	H'	J	K	L	M	N	O	P	Q	φR	S	T	U	V ₍₁₋₎	V ₍₁₋₎	V ₍₁₋₎	V ₍₁₋₎	α	φX	YxZ	X-Holes
型号	相位																														
2RB 220-7HH26	3 ~	284	316	270	45	205	230	316	135	128	106	111	83	108	75	130	39	G _{1,5x12} (15tie • deep)	64	10	2.5	88	M6×17	-	-	M25×1.5	M16×1.5	27°	140	M6×15	51°/171°/291°
2RB 320-7HH36	3 ~	293	324	286	47	205	230	354	160	141	114	120	83	108	82	138	41	G _{1,5x12} (15tie • deep)	64	10	2.5	92	M6×17	-	-	M25×1.5	M16×1.5	27°	160	M6×15	51°/171°/291°
2RB 320-7HH31	1 ~	293	324	286	47	205	230	354	160	141	114	120	83	108	82	138	41	G _{1,5x12} (15tie • deep)	64	10	2.5	92	M6×17	M25×1.5	M16×1.5	-	-	27°	160	M6×15	51°/171°/291°
2RB 420-7HH36	3 ~	322	324	315	58	225	255	401	191	154	153	128	95	130	73	151	45	G _{1,5x12} (15tie • deep)	72	12	3	104	M6×19	-	-	M25×1.5	M16×1.5	28°	174	M6×15	51°/171°/291°
2RB 420-7HH46	3 ~	322	324	315	58	225	255	401	191	154	153	128	95	130	73	151	45	G _{1,5x12} (15tie • deep)	72	12	3	104	M6×19	-	-	M25×1.5	M16×1.5	28°	174	M6×15	51°/171°/291°
2RB 420-7HA31	1 ~	322	324	315	58	225	255	401	191	154	153	128	95	130	73	151	45	G _{1,5x12} (15tie • deep)	72	12	3	104	M6×19	M16×1.5	M25×1.5	-	-	28°	174	M6×15	51°/171°/291°
2RB 420-7AV45	1 ~	322	324	315	58	225	255	401	191	154	153	128	95	130	73	151	45	G _{1,5x12} (15tie • deep)	72	12	3	104	M6×19	M16×1.5	M25×1.5	-	-	28°	174	M6×15	51°/171°/291°

Dimensions for side channel blower 2RB510.,2RB530.,2RB590(mm)

侧风道风机尺寸 2RB510.,2RB530.,2RB590(mm)

2RB 510./2RB530./2RB590.

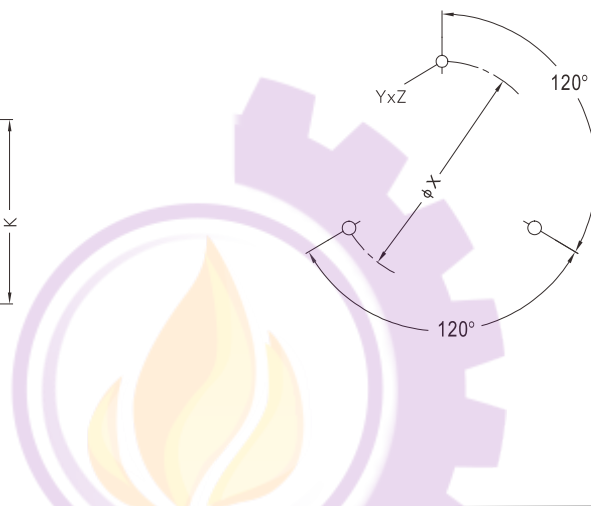
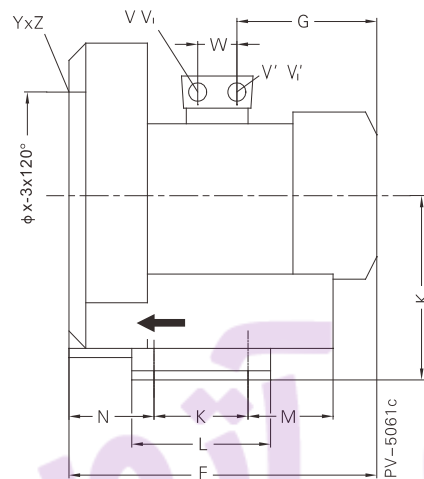
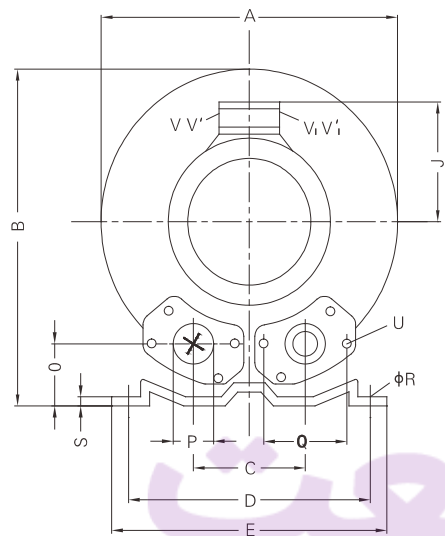

Type	Phases	A	B	C	D	E	F	G	H	J	K	L	M	N	O	φP	Q	φR	S	U	V ₍₁₋₂₎	V ₍₁₋₃₎	V ₍₂₋₃₎	V ₍₃₋₁₎	Y×Z	X-Holes	φx	W
型号	相位																											
2RB510-7AA11	1 ~	334	337	120	260	295	314	156	175	120	115	155	96	87	48	55	83	14	4	M8×17	M16×1.5	M25×1.5	-	-	M8×20	0°/120°/240°	200	29
2RB510-7AA21	1 ~	334	337	120	260	295	345	191	175	128	115	155	96	87	48	55	83	14	4	M8×17	M16×1.5	M25×1.5	-	-	M8×20	0°/120°/240°	200	29
2RB510-7AV35	1 ~	334	337	120	260	295	345	191	175	128	115	155	96	87	48	55	83	14	4	M8×17	M16×1.5	M25×1.5	-	-	M8×20	0°/120°/240°	200	29
2RB510-7AH06	3 ~	334	337	120	260	295	314	156	175	120	115	155	96	87	48	55	83	14	4	M8×17	-	-	M25×1.5	M16×1.5	M8×20	0°/120°/240°	200	29
2RB510-7AH16	3 ~	334	337	120	260	295	314	156	175	120	115	155	96	87	48	55	83	14	4	M8×17	-	-	M25×1.5	M16×1.5	M8×20	0°/120°/240°	200	29
2RB510-7AH26	3 ~	334	337	120	260	295	346	191	175	128	115	155	96	87	48	55	83	14	4	M8×17	-	-	M25×1.5	M16×1.5	M8×20	0°/120°/240°	200	29
2RB510-7AH36	3 ~	334	337	120	260	295	346	191	175	128	115	155	96	87	48	55	83	14	4	M8×17	-	-	M25×1.5	M16×1.5	M8×20	0°/120°/240°	200	29
2RB 530-7AA11	1 ~	334	337	120	260	295	334	156	175	120	115	155	96	87	48	55	83	14	4	M8×17	M16×1.5	M25×1.5	-	-	M8×20	0°/120°/240°	200	29
2RB 530-7AA21	1 ~	334	337	120	260	295	365	191	175	128	115	155	96	87	48	55	83	14	4	M8×17	M16×1.5	M25×1.5	-	-	M8×20	0°/120°/240°	200	29
2RB 530-7AH06	3 ~	334	337	120	260	295	334	156	175	120	115	155	96	87	48	55	83	14	4	M8×17	-	-	M25×1.5	M16×1.5	M8×20	0°/120°/240°	200	29
2RB 530-7AH16	3 ~	334	337	120	260	295	334	156	175	120	115	155	96	87	48	55	83	14	4	M8×17	-	-	M25×1.5	M16×1.5	M8×20	0°/120°/240°	200	29
2RB 530-7AH26	3 ~	334	337	120	260	295	365	191	175	128	115	155	96	87	48	55	83	14	4	M8×17	-	-	M25×1.5	M16×1.5	M8×20	0°/120°/240°	200	29
2RB 530-7AH36	3 ~	334	337	120	260	295	365	191	175	128	115	155	96	87	48	55	83	14	4	M8×17	-	-	M25×1.5	M16×1.5	M8×20	0°/120°/240°	200	29
2RB 530-7AV35	1 ~	334	337	120	260	295	365	191	175	128	115	155	96	87	48	55	83	14	4	M8×17	M16×1.5	M25×1.5	-	-	M8×20	0°/120°/240°	200	29
2RB 590-7AH26	3 ~	334	337	120	260	295	365	191	175	128	115	155	96	87	48	55	83	14	4	M8×17	-	-	M25×1.5	M16×1.5	M8×20	0°/120°/240°	200	29

Dimensions for side channel blower 2RB610.,2RB630.,2RB710.,2RB730.,2RB790.(mm)
侧风道风机尺寸 2RB610.,2RB630.,2RB710.,2RB730.,2RB790.(mm)

2RB 610./2RB 630./2RB710/2RB730./2RB790

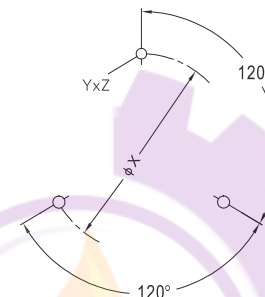
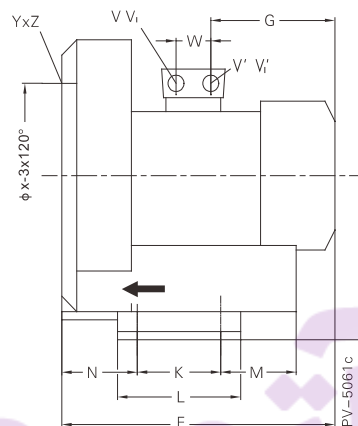
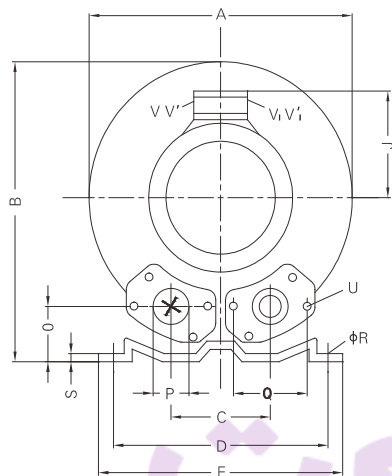

Type	Phases	A	B	C	D	E	F	G	H	J	K	L	M	N	O	φP	Q	φR	S	U	V ₍₁₋₂₎	V' ₍₁₋₂₎	V ₍₁₋₃₎	V' ₍₁₋₃₎	YxZ	X-Holes	φX	W
型号	相位																											
2RB 610-7AH06	3 ~	360	366	122	290	325	354	191	192	128	140	180	84	94	52	56	83	13	4.5	M8×17	-	-	M25×1.5	M16×1.5	M8×20	0°/120°/240°	226	29
2RB 610-7AH16	3 ~	360	366	122	290	325	354	191	192	128	140	180	84	94	52	56	83	13	4.5	M8×17	-	-	M25×1.5	M16×1.5	M8×20	0°/120°/240°	226	29
2RB 610-7AH26	3 ~	360	366	122	290	325	385	188	192	135	140	180	84	94	52	56	83	13	4.5	M8×17	M32×1.5	M32×1.5	M32×1.5	M32×1.5	M8×20	0°/120°/240°	226	42
2RB 630-7AH06	3 ~	360	366	122	290	325	372	191	192	128	140	180	84	94	52	56	83	13	4.5	M8×17	-	-	M25×1.5	M16×1.5	M8×20	0°/120°/240°	226	29
2RB 630-7AH16	3 ~	360	366	122	290	325	372	191	192	128	140	180	84	94	52	56	83	13	4.5	M8×17	-	-	M25×1.5	M16×1.5	M8×20	0°/120°/240°	226	29
2RB 630-7AH26	3 ~	360	366	122	290	325	403	188	192	135	140	180	84	94	52	56	83	13	4.5	M8×17	M32×1.5	M32×1.5	M32×1.5	M32×1.5	M8×20	0°/120°/240°	226	42
2RB 710-7AH11	1 ~	382	384	125	290	325	404	218	197	128	140	180	84	109	54	55	83	15	4.5	M8×17	M25×1.5	M16×1.5	-	-	M10×20	0°/120°/240°	240	29
2RB 710-7AH06	3 ~	382	384	125	290	325	377	191	197	128	140	180	84	109	54	55	83	15	4.5	M8×17	-	-	M25×1.5	M16×1.5	M10×20	0°/120°/240°	240	29
2RB 710-7AH16	3 ~	382	384	125	290	325	377	191	197	128	140	180	84	109	54	55	83	15	4.5	M8×17	-	-	-	-	M10×20	0°/120°/240°	240	29
2RB 710-7AH26	3 ~	382	384	125	290	325	409	188	197	135	140	180	84	109	54	55	83	15	4.5	M8×17	M32×1.5	M32×1.5	M32×1.5	M32×1.5	M10×20	0°/120°/240°	240	42
2RB 710-7AH37	3 ~	382	384	125	290	325	432	209	197	148	140	180	84	109	54	55	83	15	4.5	M8×17	M32×1.5	M32×1.5	M32×1.5	M32×1.5	M10×20	0°/120°/240°	240	42
2RB 730-7AH06	3 ~	382	384	125	290	325	387	191	197	128	140	180	84	109	54	55	83	15	4.5	M8×17	M25×1.5	M16×1.5	-	-	M10×20	0°/120°/240°	240	29
2RB 730-7AH16	3 ~	382	384	125	290	325	387	191	197	128	140	180	84	109	54	55	83	15	4.5	M8×17	M25×1.5	M16×1.5	-	-	M10×20	0°/120°/240°	240	29
2RB 730-7AH26	3 ~	382	384	125	290	325	419	189	197	135	140	180	84	109	54	55	83	15	4.5	M8×17	M32×1.5	M32×1.5	M32×1.5	M32×1.5	M10×20	0°/120°/240°	240	42
2RB 730-7AH37	3 ~	382	384	125	290	325	432	209	197	148	140	180	84	109	54	55	83	15	4.5	M8×17	M32×1.5	M32×1.5	M32×1.5	M32×1.5	M10×20	0°/120°/240°	240	42
2RB 790-7AH26	3 ~	382	384	125	290	325	377	185	197	128	140	180	84	109	54	55	83	15	4.5	M8×17	-	-	M25×1.5	M16×1.5	M10×20	0°/120°/240°	240	29

Dimensions for side channel blower 2RB520.,2RB720.,2RB740(mm)
侧风道风机尺寸 2RB520.,2RB720.,2RB740(mm)

2RB 720.-...4.
-...5.

2RB 520.-...4. 2RB 720.-...1.
-...5. -...2.

-...3.

2RB 740.-...4.
-...5.

2RB 740.-...3.

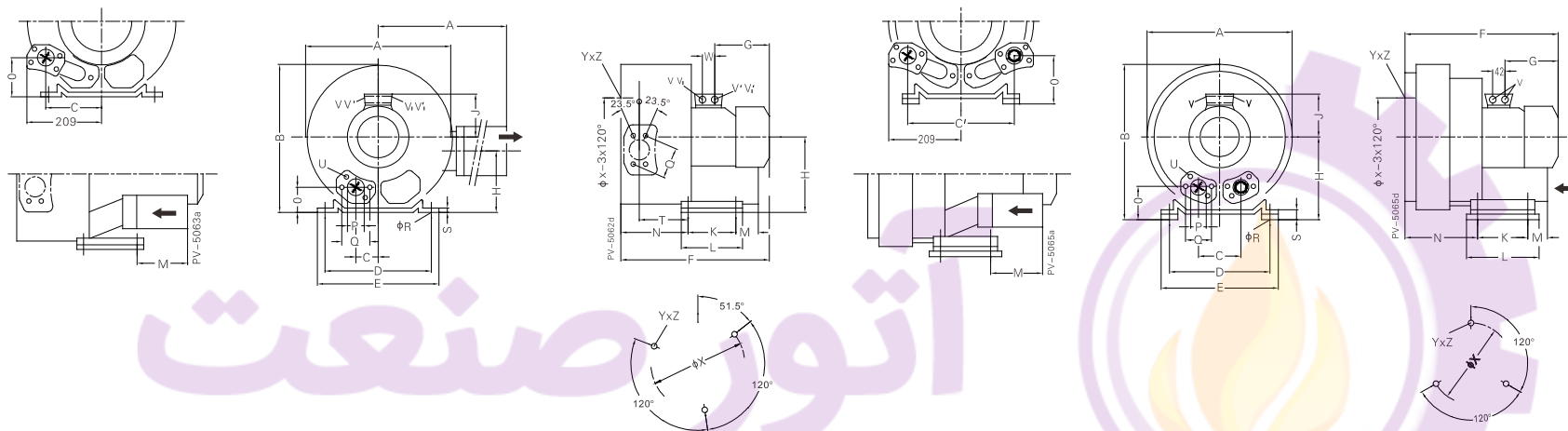

Type	Phases	A	A'	B	C	D	E	F	G	H	H'	J	K	L	M	N	O	φP	Q	φR	S	T	U	V	V'	V ₁	V ₁ '	φX	Y×Z	X-Holes	W
型号	相位																														
2RB520-7HH46	3~	372	411	371	60	260	295	465	190	175	144	135	115	155	98	171	48	55	83	14	4	116	M8×17	M32×1.5	M32×1.5	M32×1.5	M32×1.5	200	M8×20	51.5°/171.5°/291.5°	42
2RB520-7HH57	3~	372	411	371	60	260	295	499	224	175	144	135	115	155	98	171	48	55	83	14	4	116	M8×17	M32×1.5	M32×1.5	M32×1.5	M32×1.5	200	M8×20	51.5°/171.5°/291.5°	42
2RB720-7HH16	3~	426	426	420	63	290	325	473	185	197	162	128	140	180	84	205	53	55	83	15	4.5	130	M8×17	M25×1.5	M16×1.5	-	-	240	M10×20	51.5°/171.5°/291.5°	29
2RB720-7HH26	3~	426	426	420	63	290	325	507	180	197	162	135	140	180	84	205	53	55	83	15	4.5	130	M8×17	M32×1.5	M32×1.5	M32×1.5	M32×1.5	240	M10×20	51.5°/171.5°/291.5°	42
2RB720-7HH37	3~	426	426	420	63	290	325	526	209	197	162	148	140	180	84	205	53	55	83	15	4.5	130	M8×17	M32×1.5	M32×1.5	M32×1.5	M32×1.5	240	M10×20	51.5°/171.5°/291.5°	42
2RB720-7HH47	3~	426	426	420	154	290	325	571	226	197	162	167	140	180	225	205	94	55	83	15	4.5	130	M8×17	M32×1.5	M32×1.5	M32×1.5	M32×1.5	240	M10×20	51.5°/171.5°/291.5°	42
2RB720-7HH57	3~	426	426	420	154	290	325	571	226	197	162	167	140	180	225	205	94	55	83	15	4.5	130	M8×17	M32×1.5	M32×1.5	M32×1.5	M32×1.5	240	M10×20	51.5°/171.5°/291.5°	42

Type	Phases	A	B	C	C'	D	E	F	G	H	J	K	L	M	N	O	φP	Q	φR	S	U	V	φX	Y×Z	X-Holes
型号	相位																								
2RB 740-7GH37	3~	420	468	125	-	290	325	526	209	257	148	140	180	84	205	114	55	83	15	64.5	M8×17	4×M32×1.5	240	M10×20	0°/120°/240°
2RB 740-7GH47	3~	420	468	-	308	290	325	571	226	257	167	140	180	225	205	114	55	83	15	64.5	M8×17	4×M32×1.5	240	M10×20	0°/120°/240°
2RB 740-7GH57	3~	420	468	-	308	290	325	571	226	257	167	140	180	225	205	114	55	83	15	64.5	M8×17	4×M32×1.5	240	M10×20	0°/120°/240°

Diemensions for side channel blower 2RB810.,2RB820.,2RB830.,2RB840.(mm)

侧风道风机尺寸 2RB810.,2RB820.,2RB830.,2RB840.(mm)

2RB 810./2RB 830.

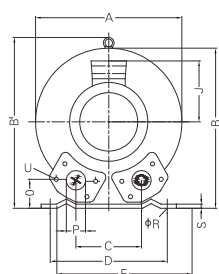

2RB 820.-...1.

-...2.

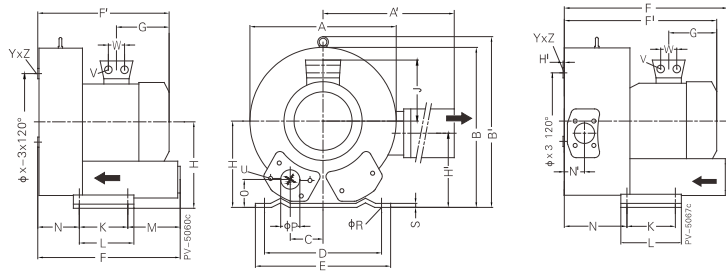

2RB 840.-...2.

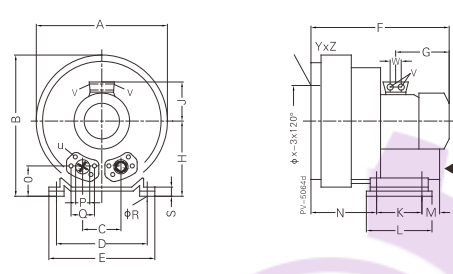

2RB 820.-...3.

-...4.

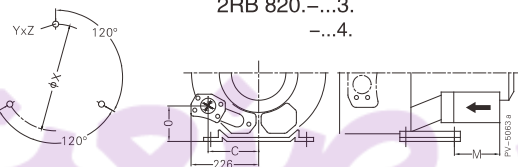

2RB 840.-...3.

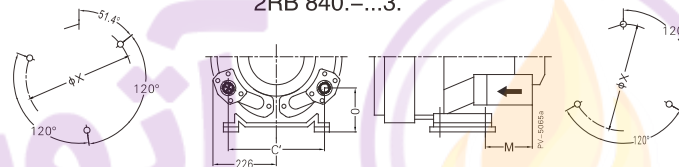

Type	Phases	A	A'	B	B'	C	D	E	F	F'	G	H	H'	J	K	L	M	N	N'	O	φP	φR	S	V	W	φX	YxZ	X-Holes
型号	相位																											
2RB810-7AH07	3 ~	451	-	461	509	152	356	433	433	450	230	240	-	148	170	217	140	124	-	65	65	15	6	4×M32×1.5	42	286	M12x20	0°/120°/240°
2RB810-7AH17	3 ~	451	-	461	509	152	356	433	433	477	247	240	-	148	170	217	140	124	-	65	65	15	6	4×M32×1.5	42	286	M12x20	0°/120°/240°
2RB810-7AH27	3 ~	451	-	461	509	152	356	433	433	477	247	240	-	148	170	217	140	124	-	65	65	15	6	4×M32×1.5	42	286	M12x20	0°/120°/240°
2RB820-7AH17	3 ~	500	549	490	509	-	356	545	545	589	247	240	199	148	170	217	140	236	84	65	65	15	6	4×M32×1.5	42	286	M12x20	58.5°/171.5°/291.5°
2RB820-7AH27	3 ~	500	549	490	509	-	356	545	545	589	247	240	199	167	170	217	140	236	84	65	65	15	6	4×M32×1.5	42	286	M12x20	58.5°/171.5°/291.5°
2RB820-7AH37	3 ~	500	549	490	509	-	356	545	717	694	318	240	199	197	170	217	312	212	84	105	65	15	6	4×M32×1.5	54	286	M12x20	58.5°/171.5°/291.5°
2RB820-7AH47	3 ~	500	549	490	509	152	356	545	717	694	318	240	199	197	170	217	312	212	84	105	65	15	6	4×M32×1.5	54	286	M12x20	58.5°/171.5°/291.5°
2RB830-7AH07	3 ~	451	-	461	509	152	356	449	449	466	230	240	-	148	170	217	140	139	-	65	65	15	6	4×M32×1.5	42	286	M12x20	0°/120°/240°
2RB830-7AH17	3 ~	451	-	461	509	152	356	449	449	492	247	240	-	167	170	217	140	139	-	65	65	15	6	4×M32×1.5	42	286	M12x20	0°/120°/240°
2RB830-7AH27	3 ~	451	-	461	509	152	356	449	449	492	247	240	-	167	170	217	140	139	-	65	65	15	6	4×M32×1.5	42	286	M12x20	0°/120°/240°

Type	Phases	A	B	C	C'	D	E	F	G	H	J	K	L	M	N	O	φP	φR	S	V	W	φX	YxZ	X-Holes
型号	相位																							
2RB 840-7GH27	3 ~	500	550	152	-	356	394	589	226	300	167	170	217	140	236	125	65	15	66	4×M32×1.5	42	286	M12x20	0°/120°/240°
2RB 840-7GH37	3 ~	500	550	-	336	356	394	694	318	300	197	170	217	312	212	165	65	15	66	4×M40×1.5	54	286	M12x20	0°/120°/240°

Diemensions for side channel blower 2RB910.,2RB920.,2RB930(mm)
侧风道风机尺寸 2RB910.,2RB920.,2RB930(mm)

2RB910./2RB930.

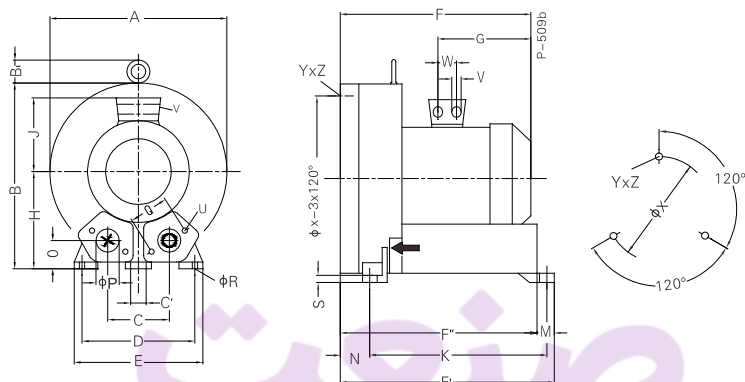

2RB920.

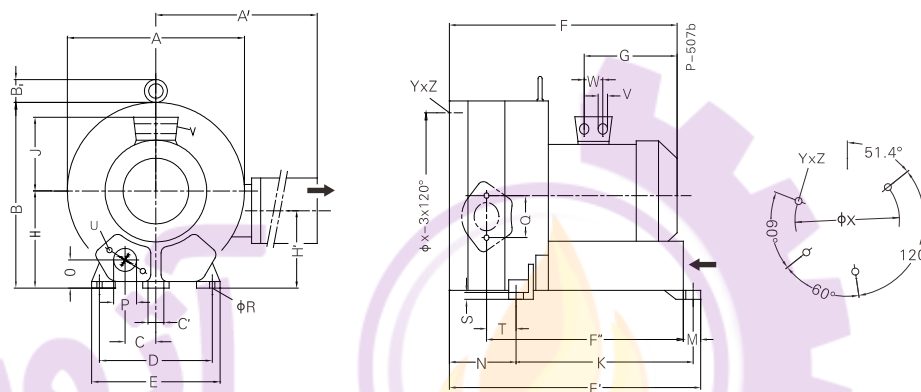

Type	Phases																									X-Holes		
型号	相位	A	B	B'	C	C'	D	E	F	F'	F''	G	H	J	K	M	N	O	φP	Q	φR	S	U	V	W	φX	Y×Z	
2RB910-7AH07	3~	550	569	55	207	15	360	415	525	644	605	268	300	167	533	39	89	92	100	150	15	21	M12×30	4×M32×1.5	42	490	M12×30	0°/120°/240°
2RB910-7AH17	3~	550	569	55	207	15	360	415	611	644	605	345	300	197	533	39	89	92	100	150	15	21	M12×30	4×M32×1.5	54	490	M12×30	0°/120°/240°
2RB910-7AH37	3~	550	569	55	207	15	360	415	611	644	605	345	300	197	533	39	89	92	100	150	15	21	M12×30	4×M32×1.5	54	490	M12×30	0°/120°/240°
2RB930-7AH07	3~	550	569	55	207	15	360	415	563	682	643	268	300	167	533	39	127	92	100	150	15	21	M12×30	4×M32×1.5	42	490	M12×30	0°/120°/240°
2RB930-7AH17	3~	550	569	55	207	15	360	415	649	682	643	345	300	197	533	39	127	92	100	150	15	21	M12×30	4×M32×1.5	54	490	M12×30	0°/120°/240°
2RB930-7AH37	3~	550	569	55	207	15	360	415	649	682	643	345	300	197	533	39	127	92	100	150	15	21	M12×30	4×M32×1.5	54	490	M12×30	0°/120°/240°

Type	Phases																									X-Holes					
型号	相位	A	A'	B	B'	C	C'	D	E	F	F'	F''	G	H	H'	J	K	M	N	O	φP	Q	φR	S	T	U	V	W	φX	Y×Z	
2RB 920-7HH17	3~	615	780	607	55	103.5	15	360	415	752	786	634	345	300	236	197	533	39	230	92	100	150	15	21	117	M12×30	4×M40×1.5	54	490	M12x30	51°/120°/240°
2RB 920-7HH27	3~	615	780	607	55	103.5	15	360	415	752	786	634	345	300	236	197	533	39	230	92	100	150	15	21	117	M12×30	4×M40×1.5	54	490	M12x30	51°/120°/240°
2RB 920-7HH37	3~	615	780	607	55	103.5	15	360	415	752	786	634	345	300	236	197	533	39	230	92	100	150	15	21	117	M12×30	4×M40×1.5	54	490	M12x30	51°/120°/240°
2RB 920-7HH47	3~	615	780	607	55	103.5	15	360	415	812	786	634	345	300	236	197	533	39	230	92	100	150	15	21	117	M12×30	4×M40×1.5	54	490	M12x30	51°/120°/240°

Diemensions for side channel blower 2RB940.,2RB943.(mm)
侧风道风机尺寸 2RB940.,2RB943.(mm)

2RB940.

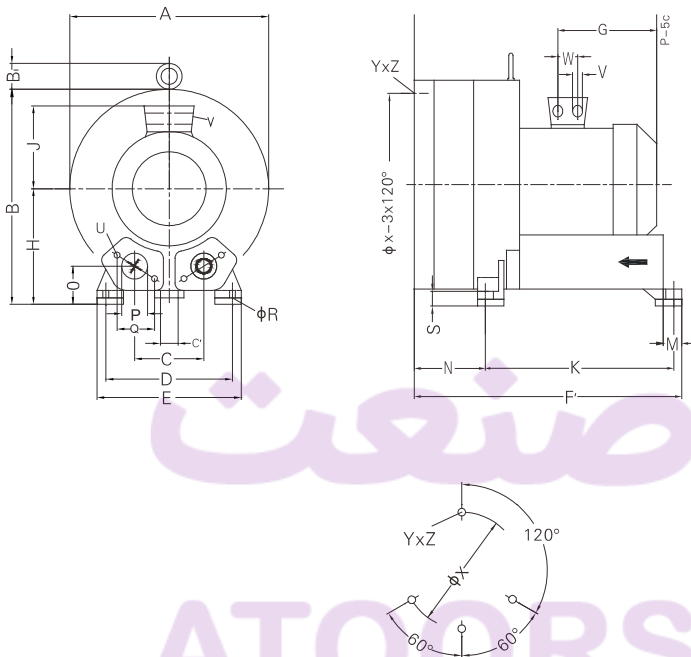

2RB943.

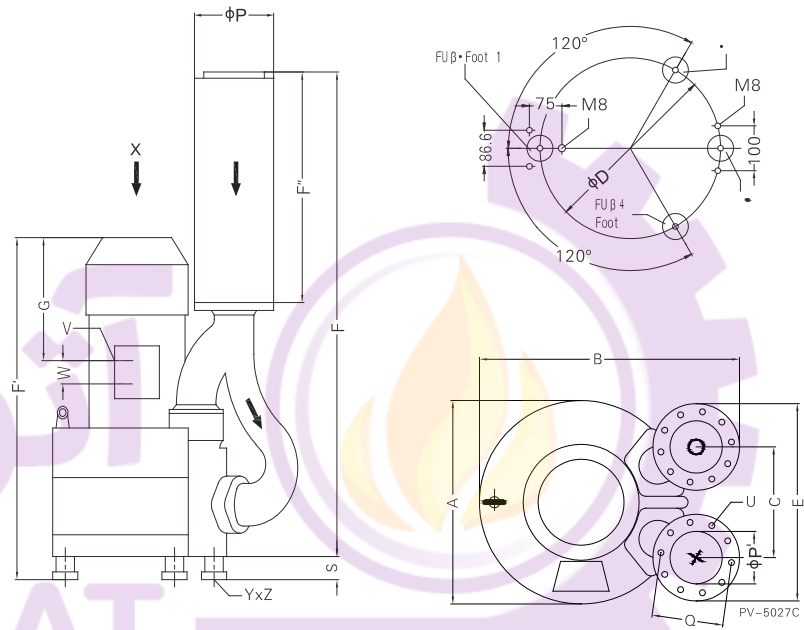

Type	Phases	A	B	B ₁	C	C'	D	E	F	F'	G	H	J	K	M	N	O	φP	Q	φR	S	U	V	W	φX	YxZ	X-Holes
型号	相位	A	B	B ₁	C	C'	D	E	F	F'	G	H	J	K	M	N	O	φP	Q	φR	S	U	V	W	φX	YxZ	X-Holes
2RB940-7BH27 ¹⁾	3~	615	663	55	207	15	360	415	752	786	345	350	197	533	39	230	132	100	140	15	79	M12×35	4×M40×1.5	54	490	M12×30	0°/120°/240°
2RB940-7BH37 ¹⁾	3~	615	663	55	207	15	360	415	752	786	345	350	197	533	39	230	132	100	140	15	79	M12×35	4×M40×1.5	54	490	M12×30	0°/120°/240°
2RB940-7BH47 ¹⁾	3~	615	663	55	207	15	360	415	752	786	345	350	197	533	39	230	132	100	140	15	79	M12×35	4×M40×1.5	54	490	M12×30	0°/120°/240°

Type	Phases	A	B	C	D	E	F	F'	F''	G	P	P'	Q	S	U	V	W	YxZ
型号	相位	A	B	C	D	E	F	F'	F''	G	P	P'	Q	S	U	V	W	YxZ
2RB943-7GH27 ¹⁾	3~	615	723	307	490	526	1201	848	578	291	219	135	201	58	M8×40	4×M40×1.5	54	M12×10.5
2RB943-7GH37 ¹⁾	3~	615	723	307	490	526	1201	848	578	291	219	135	201	58	M8×40	4×M40×1.5	54	M12×10.5
2RB943-7GH47 ¹⁾	3~	615	723	307	490	526	1201	848	578	291	219	135	201	58	M8×40	4×M40×1.5	54	M12×10.5

Dimensions for side channel blower 4RB210.,4RB310.,4RB410.,4RB510.,4RB610.(mm)
侧风道风机尺寸 4RB210.,4RB310.,4RB410.,4RB510.,4RB610.(mm)

4RB210./4RB310./4RB410./4RB510./4RB610.

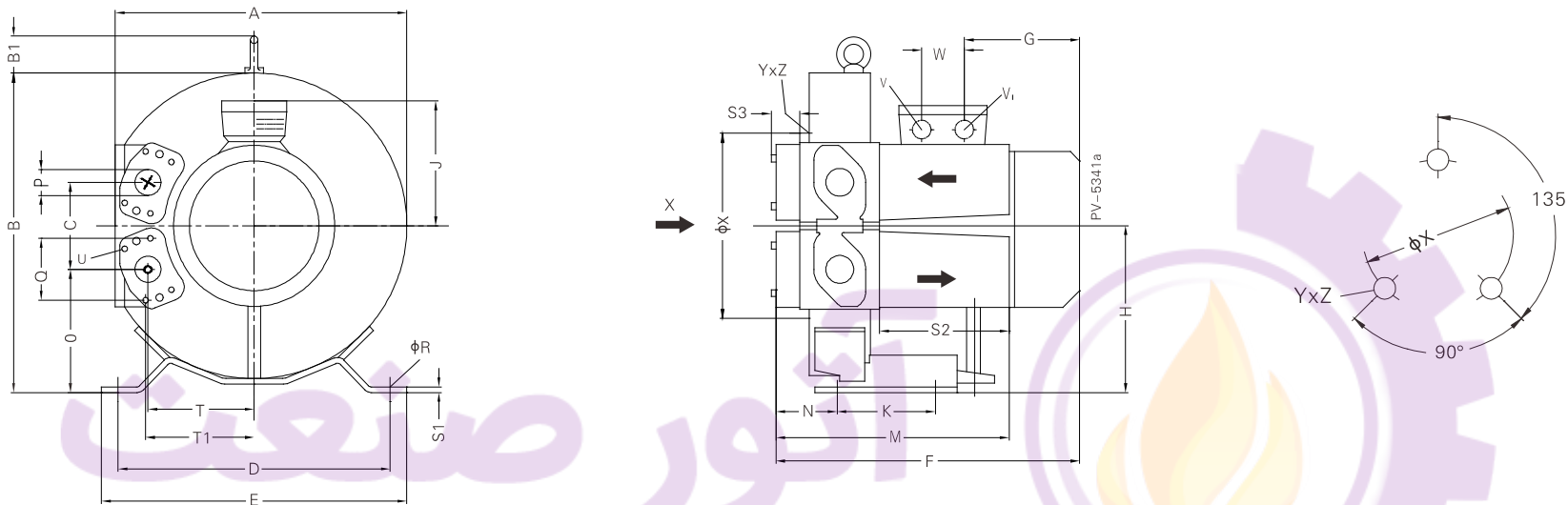

Type	Phases	A	B	B'	C	D	E	F	G	H	J	K	M	N	O	P	Q	ϕR	S ₁	S ₂	S ₃	T	T ₁	U	V	V ₁	W	ϕX	YxZ
型号	相位																												
4RB210-0AH16-7	3 ~	294	319	39	87	260	298	293	129	167	111	105	252	65	124	G1 1/4(18deep)	64	14	4	140	31	105	107	M6x17	M25x1.5	M16x1.5	32	153	M6x15
4RB210-0AV75-7	1 ~	294	319	39	87	260	298	293	129	167	111	105	252	65	124	G1 1/4(18deep)	64	14	4	140	31	105	107	M6x17	M25x1.5	M16x1.5	32	153	M6x15
4RB310-0AH16-7	3 ~	313	339	39	94	290	325	295	153	177	120	105	256	67	130	G1 1/4(18deep)	64	14	4	140	31	114	116	M6x17	M25x1.5	M16x1.5	32	153	M6x15
4RB310-0AH26-7	3 ~	313	339	39	94	290	325	295	153	177	120	105	256	67	130	G1 1/4(18deep)	64	14	4	140	31	114	116	M6x17	M25x1.5	M16x1.5	32	153	M6x15
4RB310-0AH71-7	1 ~	313	339	39	94	290	325	295	153	177	120	105	256	67	130	G1 1/4(18deep)	64	14	4	140	31	114	116	M6x17	M25x1.5	M16x1.5	32	153	M6x15
4RB310-0AH75-7	1 ~	313	339	39	94	290	325	295	153	177	120	105	256	67	130	G1 1/4(18deep)	64	14	4	140	31	114	116	M6x17	M25x1.5	M16x1.5	32	153	M6x15
4RB410-0AH16-7	3 ~	346	375	38	103	315	350	321	153	195	120	130	260	66	143	G1 1/4(18deep)	64	14	4	140	31	125	127	M6x17	M25x1.5	M16x1.5	32	167	M6x15
4RB410-0AA41-7	1 ~	346	375	38	103	315	350	321	153	195	120	130	260	66	143	G1 1/4(18deep)	64	14	4	140	31	125	127	M6x17	M25x1.5	M16x1.5	32	167	M6x15
4RB510-0AH16-8	3 ~	368	395	39	114	328	363	361	185	205	128	152	265	68	148	G1 1/4(18deep)	64	14	5	140	31	137	138	M6x17	M25x1.5	M16x1.5	32	192	M8x15
4RB510-0AH26-8	3 ~	368	395	39	114	328	363	361	185	205	128	152	265	68	148	G1 1/4(18deep)	64	14	5	140	31	137	138	M6x17	M25x1.5	M16x1.5	32	192	M8x15
4RB610-0AH16-8	3 ~	418	455	39	127	371	406	364	185	235	128	152	271	72	172	G1 1/4(18deep)	64	14	5	140	31	153	155	M6x17	M25x1.5	M16x1.5	32	228	M8x15
4RB610-0AH36-8	3 ~	418	455	39	127	371	406	390	211	235	128	152	271	72	172	G1 1/4(18deep)	64	14	5	140	31	153	155	M6x17	M25x1.5	M16x1.5	32	228	M8x15

Diemensions for side channel blower 4RB220.,4RB320.,4RB420.,4RB520.,4RB620.,4RB630.(mm)
侧风道风机尺寸 4RB220.,4RB320.,4RB420.,4RB520.,4RB620.,4RB630.(mm)

4RB220./4RB320/4RB420./4RB520./4RB620./4RB630.

4RB630.

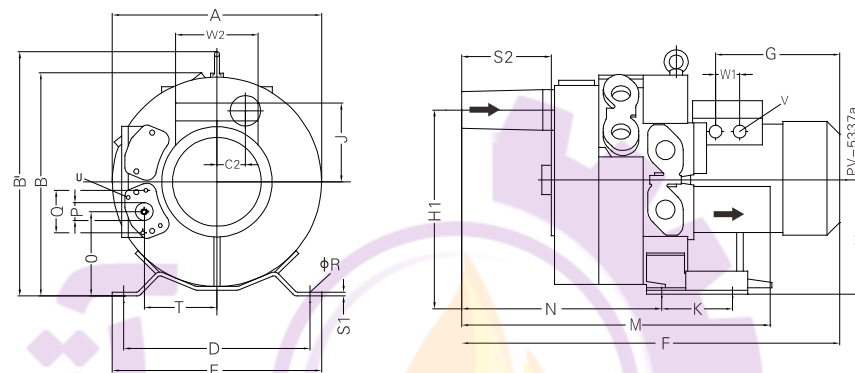
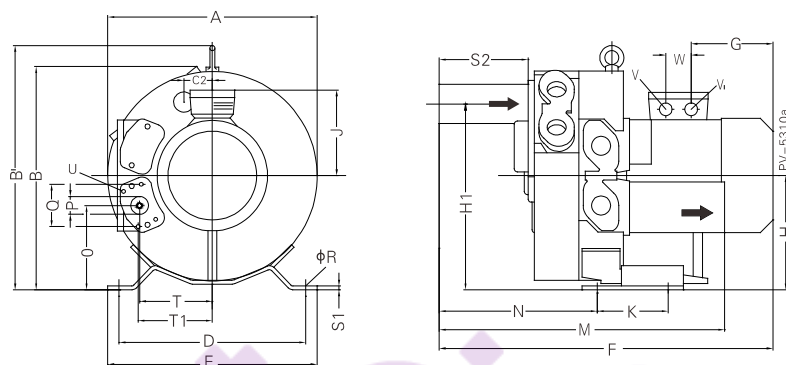

Type	Phases	A	B	B'	C ₂	D	E	F	H	H ₁	J	K	M	N	O	P	Q	φR	S ₁	S ₂	S ₃	T	T ₁	U	V	V ₁	W
型号	相位																										
4RB220-0AH26-7	3 ~	313	326	359	43	260	298	469	167	272	111	105	426	241	123	G1 1/4(18deep)	64	14	4	140	31	105	107	M6x17	M25x1.5	M16x1.5	32
4RB220-0AH56-7	3 ~	313	326	359	43	260	298	525	167	272	128	105	426	241	123	G1 1/4(18deep)	64	14	4	140	31	105	107	M6x17	M25x1.5	M16x1.5	32
4RB220-0AH75-7	1 ~	313	326	359	43	260	298	525	167	272	128	105	426	241	123	G1 1/4(18deep)	64	14	4	140	31	105	107	M6x17	M25x1.5	M16x1.5	32
4RB320-0AH46-7	3 ~	331	345	380	47	290	325	390	177	291	120	105	431	243	130	G1 1/4(18deep)	64	14	4	140	31	114	116	M6x17	M25x1.5	M16x1.5	32
4RB320-0AH56-7	3 ~	331	345	380	47	290	325	421	177	291	128	105	431	243	130	G1 1/4(18deep)	64	14	4	140	31	114	116	M6x17	M25x1.5	M16x1.5	32
4RB320-0AH75-7	1 ~	331	345	380	47	290	325	421	177	291	128	105	431	243	130	G1 1/4(18deep)	64	14	4	140	31	125	127	M6x17	M25x1.5	M16x1.5	32
4RB420-0AH26-7	3 ~	363	377	414	52	315	350	529	195	319	128	130	436	243	143	G1 1/4(18deep)	64	14	4	140	31	125	127	M6x17	M25x1.5	M16x1.5	32
4RB420-0AH56-8	3 ~	363	377	414	52	315	350	554	195	319	128	130	436	243	143	G1 1/4(18deep)	64	14	4	140	31	125	127	M6x17	M25x1.5	M16x1.5	32
4RB520-0AH26-8	3 ~	387	402	435	57	328	363	549	206	343	128	152	453	256	148	G1 1/4(18deep)	64	14	5	140	31	137	138	M6x17	M25x1.5	M16x1.5	42
4RB520-0AH77-8	3 ~	387	402	435	57	328	363	603	206	343	148	152	453	256	148	G1 1/4(18deep)	64	14	5	140	31	137	138	M6x17	2×M32x1.5	M16x1.5	32
4RB620-0AH36-8	3 ~	442	457	495	63	372	406	578	236	389	128	152	458	259	173	G1 1/4(18deep)	64	14	5	140	31	153	155	M6x17	M25x1.5	M16x1.5	42
4RB620-0AH57-8	3 ~	442	457	495	63	372	406	643	236	389	148	152	458	259	173	G1 1/4(18deep)	64	14	5	140	31	153	155	M6x17	2×M32x1.5	M16x1.5	

Type	A	B	B'	C ₂	D	E	F	G	H	H ₁	K	M	N	O	P	Q	φR	S ₁	S ₂	T	U	V	W ₁	W ₂
型号																								
4RB630-0AH67-8	442	402	492	63	371	406	717	274	236	389	152	539	336	172	G1 1/4(18deep)	64	14	5	146	153	M6x17	M32x1.5	42	120

Diemensions for belt drive side channel blower

皮带式侧风道风机尺寸

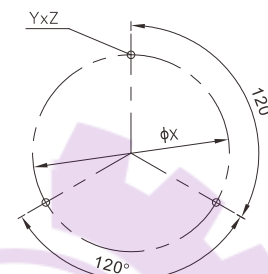
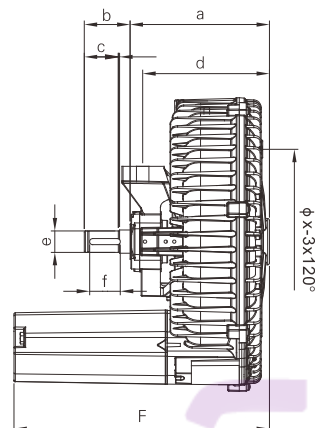
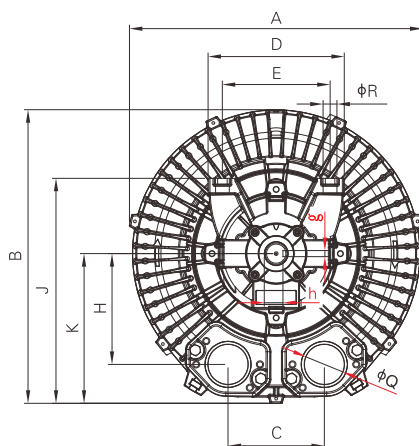

型号 Type	A	B	C	D	E	F	H	J	K	φQ	φR
2RB 213-1HY99	246	240	90	157	125	230	89	211	125	40	14
2RB 233-1HY99	246	240	90	157	125	241	89	211	125	40	14
2RB 313-1HY99	268	267	93	157	125	233	100	222	136	40	14
2RB 333-1HY99	268	267	93	157	125	249	100	222	136	40	14
2RB 413-1HY99	286	300	115	157	125	240	108	233	148	45	14
2RB 433-1HY99	286	300	115	157	125	256	108	233	148	45	14
2RB 513-1HY99	334	324	120	177	140	297	127	268	169	55	18
2RB 533-1HY99	334	324	120	177	140	316	127	268	169	55	18
2RB 613-1HY99	360	358	122	177	140	318	135	281	183	55	18
2RB 633-1HY99	360	358	122	177	140	336	135	281	183	55	18
2RB 713-1HY99	382	382	125	177	140	333	144	292	194	55	18
2RB 733-1HY99	382	382	125	177	140	343	144	292	194	55	18
2RB 813-1HY99	451	461	152	245	195	433	175	265	230	68	24
2RB 833-1HY99	451	461	152	245	195	450	175	265	230	68	24
型号 Type	a	b	c	d	e	f	g	h	n	Y*Z	φX
2RB 213-1HY99	140	51	43	2	24	40	8	20	128	M6x15	140
2RB 233-1HY99	151	51	43	2	24	40	8	20	139	M6x15	140
2RB 313-1HY99	140	51	43	2	24	40	8	20	128	M6x15	160
2RB 333-1HY99	156	51	43	2	24	40	8	20	134	M6x15	160
2RB 413-1HY99	143	53	43	2	24	40	8	20	130	M6x15	174
2RB 433-1HY99	159	53	43	2	24	40	8	20	146	M6x15	174
2RB 513-1HY99	169	60	44	2	28	40	8	24	156	M8x20	200
2RB 533-1HY99	188	60	44	2	28	40	8	24	175	M8x20	200
2RB 613-1HY99	175	60	44	2	28	40	8	24	163	M8x20	226
2RB 633-1HY99	193	60	44	2	28	40	8	24	181	M8x20	226
2RB 713-1HY99	182	60	44	2	28	40	8	24	169	M10x20	240
2RB 733-1HY99	192	60	44	2	28	40	8	24	179	M10x20	240
2RB 813-1HY99	227	85	78	2	42	60	12	37	210	M12x20	286
2RB 833-1HY99	244	85	78	2	42	60	12	37	227	M12x20	286

Dimensions for belt drive side channel blower 皮带式侧风道风机尺寸

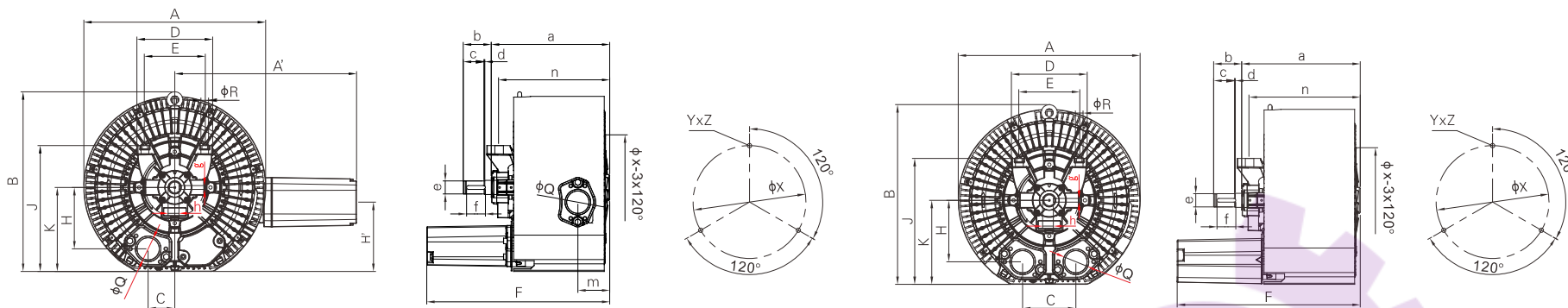

型号 Type	A	A'	B	C	D	E	F	H	H'	J	K	φQ	φR
2RB 223-1HY99	285	217	270	45	157	125	288	89	106	214	128	40	14
2RB 323-1HY99	297	323	289	46	157	125	302	100	114	227	141	40	14
2RB 423-1HY99	322	322	315	58	157	125	316	108	153	240	154	45	14
2RB 523-1HY99	371	411	361	60	177	140	383	127	145	275	175	55	18
2RB 723-1HY99	426	426	421	63	177	140	429	144	162	295	197	55	18
2RB 823-1HY99	500	549	500	76	245	195	545	175	195	365	230	68	24
型号 Type	a	b	c	d	e	f	g	h	m	n	Y*Z	φX	
2RB 223-1HY99	199	51	43	2	24	40	8	20	42	186	M6×15	140	
2RB 323-1HY99	209	51	43	2	24	40	8	20	46	196	M6×15	160	
2RB 423-1HY99	219	53	43	2	24	40	8	20	46	207	M6×15	174	
2RB 523-1HY99	255	60	44	2	24	40	8	24	55	241	M8×20	200	
2RB 723-1HY99	278	60	44	2	24	40	8	24	75	265	M10×20	240	
2RB 823-1HY99	240	85	78	2	24	40	12	37	84	322	M12×20	286	

型号 Type	A	B	C	D	E	F	H	J	K	φQ	φR
2RB 743-1HY99	426	421	63	177	140	429	144	295	197	55	18
2RB 843-1HY99	500	500	152	245	195	545	175	365	230	68	24
型号 Type	a	b	c	d	e	f	g	h	n	Y*Z	φX
2RB 743-1HY99	278	60	44	2	28	40	8	24	265	M10×20	240
2RB 843-1HY99	340	85	74	2	42	60	12	37	322	M10×20	286

Dimensions for belt drive side channel blower

皮带式侧风道风机尺寸

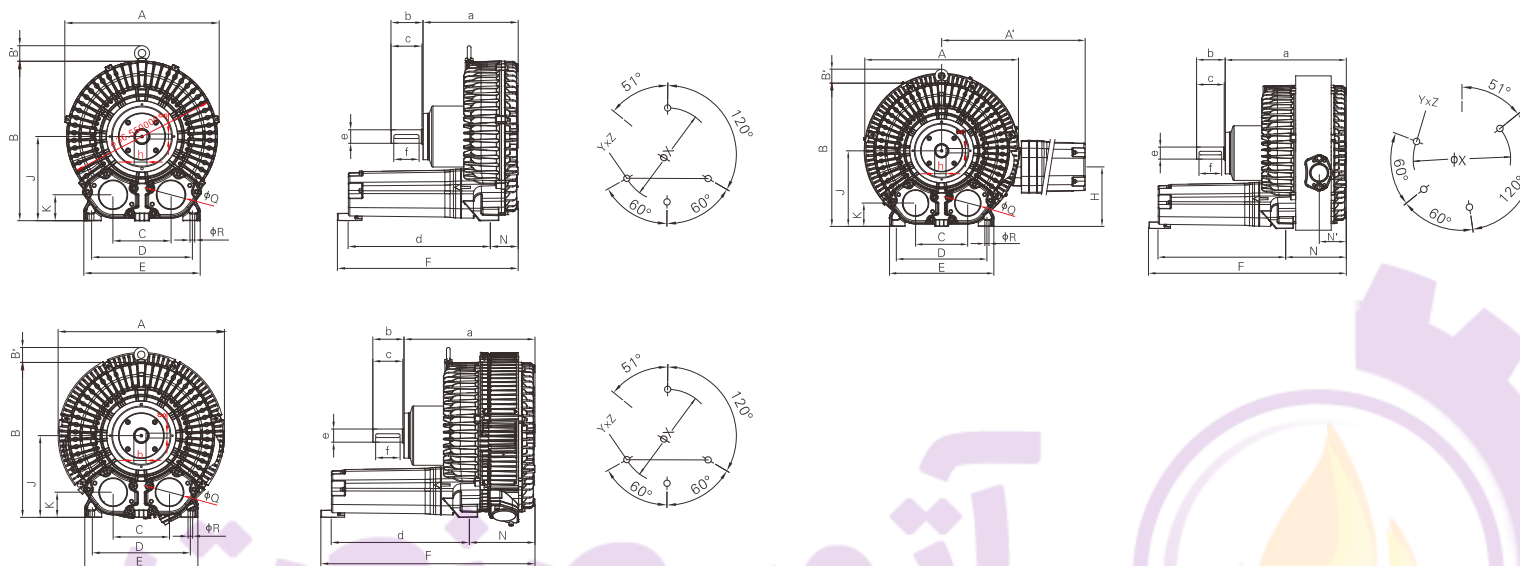

型号 Type	A	B	B'	C	D	E	F	J	K	N	φQ	φR
2RB 913-1HY99	550	569	55	207	360	415	644	300	92	127	100	15
2RB 933-1HY99	550	569	55	207	360	415	682	300	92	127	100	15
型号 Type	a	b	c	d	e	f	h	g	Y*Z	φX		
2RB 913-1HY99	340	114	110	533	48	90	42	14	M12×30	490		
2RB 933-1HY99	378	114	110	533	48	90	42	14	M12×30	490		

型号 Type	A	A'	B	B'	C	D	E	F	J	H	K	N	N'
2RB 943-1HY99	615	780	569	55	207	360	415	785	300	234	92	230	113
型号 Type	a	b	c	d	e	f	h	g	Y*Z	φX	φQ	φR	
2RB 943-1HY99	480	114	110	533	48	90	42	14	M12×30	490	100	15	

型号 Type	A	B	B'	C	D	E	F	J	K	N	φQ	φR
2RB 943-1HY99	615	569	55	207	360	415	785	300	92	230	100	15
型号 Type	a	b	c	d	e	f	h	g	Y*Z	φX		
2RB 943-1HY99	480	114	110	533	48	90	42	14	M12×30	490		

附录 Annex



换算表 Conversion tables	70
通用安全信息 General safety information	71
电压总览及脚注 Overview of the voltage and footnotes	72

附录 Annex

换算表

Conversion tables

压力换算表 Pressure		
初始单位 Beginning units	换算因子 Conversion factor	目标单位 Resulting units
Pa	0.01	Mbar
hPa	1.0	mbar
kPa	10.0	mbar
mmH ₂ O	0.098	mbar
mH ₂ O	98.07	mbar
at	980.7	mbar
inch H ₂ O	2.491	mbar
PSI lpt/in ²	68.948	mbar
mbar	100	Pa
mbar 1	10.2	mm H ₂ O
mbar	10.2·10 ⁻³	M H ₂ O
mbar	1.02·10 ⁻³	at
mbar	0.4016	inch H ₂ O
mbar	14.505·10 ⁻³	PSI lpt/in ²

换算举例

250[inch H₂O]·2.491=622.5[mbar]

下面的公式用来把“以水银柱高度度量的真空度”换算成“绝对压力”

1013-x[inches of mercury vacuum]·33.8=Y[mbar abs.]

绝对压力

绝压是以理想真空（绝压为零）为基准而得到的测量值。所以绝压总是比参考值大。

表压

表压是指高于标准大气压压力的测量值。即以标准大气压为基准。

因此实际测量值总是比基准值大。

真空度

真空度是指低于标准大气压压力的测量值。测量基准仍为标准大气压，所以

实际测量值总比基准值小。

Example of conversion

250[inch H₂O]·2.491=622.5[mbar]

The following formula is used to convert value from "inches of mercury vacuum" to "mbar abs"

1013-x[inches of mercury vacuum]·33.8=Y[mbar abs.]

Absolute pressure

The pressure measured from absolute zero, using ideal vacuum as the datum. The measured pressure is always greater than the reference pressure.

Total pressure difference, pressure

The pressure measured above the prevailing atmospheric pressure. The datum is the prevailing atmospheric pressure and the measured pressure is always higher than the datum.

Total pressure difference, vacuum

The pressure measured lower than the prevailing atmospheric pressure. The datum is the prevailing atmospheric pressure and the measured pressure is always lower than the datum.

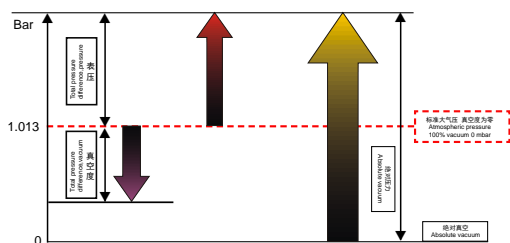

抽吸能力换算表 Suction capacity		
初始单位 Beginning units	换算因子 Conversion factor	目标单位 Resulting units
l/min	0.06	m ³ /h
gal/min	0.227	m ³ /h
ft ³ /min	1.699	m ³ /h
m ³ /h	16.667	i/min
m ³ /h	4.403	gal/min
m ³ /h	0.588	ft ³ /min

功率换算表 Electrical power		
初始单位 Beginning units	换算因子 Conversion factor	目标单位 Resulting units
hp	0.746	kW
btu/h	293.1	kW
kW	1.341	hp
kW	3.41·10 ⁻³	Btu/h

重量换算表 Weight		
初始单位 Beginning units	换算因子 Conversion factor	目标单位 Resulting units
lbn	0.454	kg
kg	2.205	lbn

长度换算表 Length		
初始单位 Beginning units	换算因子 Conversion factor	目标单位 Resulting units
in.	25.4mm	
in.	0.0254	m
ft	305	mm
ft	0.305	m
m	39.37	in.
m	3.28	f

温度换算表 Temperature conversion		
换算 Conversion 自 from	至 to	
°F	K	$T [K] = \frac{T [°F] + 459.67}{1.8}$
°F	°C	$t [°C] = \frac{T [°F] - 32}{1.8}$
K	°F	$t [°F] = 1.8 \cdot T [K] - 459.67$
°C	°F	$t [°F] = 1.8 \cdot t [°C] + 32$

通用安全信息

General safety information

备注:

本产品目录中的各个产品有如下方面应用: ■资本货物工业 ■消费品工业 ■农业工业 ■建筑业 ■综合贸易

这类设备通常包括裸露部分,由于它们在工作过程的很多情况下为运动部件或旋转部件,所以很危险,此类部件可能导致严重的人身伤亡或设备故障,例如未经许可的防护罩的拆除,不正当使用,操作不当或维护不足。

因此负责安全的工作人员必须确保:

- 只有有资格的相关人员才能操作此类设备。
- 资格人员在操作这些设备是已经完全熟悉操作手册并且能系统地按照手册的指导去操作。
- 非资格人员不允许操作此类设备。

资格人员

是指有厂区安全负责人授权的人员。他们根据自有的培训、经验、相关标准的知识及对事故预防的能力来完成某项必要的工作,同时能意识到潜在的危险并采取必要的防范措施。

有必要的生命急救知识,熟悉相关的生命救护设备。

DIN VDE 0105 或 IEC 364 规定,非资格人员不得从事电气设备的工作。

随设备而来的操作说明书不可能包含所有涉及要素的详细信息,尤其不可能把每一种可能的安装,操作及维护方式都涉及到。因此这些操作手册只包括能让资格人员正确操作机器或设备的必要信息。

因此有必要澄清一下,如果缺乏产品的详细参数,请根据此产品的设备类型和加工代号,联系我们。

建议: 有我们的服务中心来完成您设备的安装、调度及售后服务工作。

NOTE:

The products in this catalogue are used in the ■ capital goods industry ■ consumer goods industry and in such sectors as ■ agriculture ■ the building industry and ■ allied trades.

This equipment has bare parts that are dangerous because they are live during operation; in some cases these are moving or rotating parts. Such parts could cause severe injury to persons and severe damage to property, for example in the event of unauthorised removal of protective covers, improper use, wrong operation or insufficient maintenance.

The people in charge of safety must therefore guarantee that:

- only qualified personnel are allowed to work on or around this equipment;
- these persons have access at all times to the operating instructions supplied and all other elements of the product documentation when working with the equipment, and are obliged to systematically follow the instructions given therein;
- unqualified personnel are not allowed to work on these machines or equipment or in the vicinity thereof.

Qualified personnel

are persons who on account of their training, experience, instruction, knowledge of the appropriate standards, specifications, accident prevention regulations and the operating environment have been authorised by those responsible for plant safety to perform the necessary work and at the same time to recognise and circumvent potential hazards.

Knowledge of first aid and familiarity with the pertinent life-saving equipment are also necessary.

The barring of unqualified personnel from work on heavy-current equipment is regulated by DIN VDE 0105 or IEC 364.

For the sake of clarity, the operating instructions supplied with the equipment cannot contain all the detailed information on possible design variants and in particular cannot take into account every conceivable type of installation, operation or maintenance. The operating instructions therefore basically contain only the information necessary to enable qualified personnel (see above) to operate the machines or equipment correctly in industrial applications.

In the event that the machines or equipment are intended for service outside of industry, where more exacting demands may be placed on them (such as touch protection for children), the installation work must be supplemented by further protective measures that are to be implemented locally.

Where clarifications are necessary, particularly with respect to lack of product-specific detailed information, please contact the sales office concerned, quoting the type designation and manufacturing number of the machine or equipment.

G_ 系列 G_Series

电压概况 Voltage Overview

50Hz 电压 Voltages at 50 Hz			
2RB...-...□.□			
3 相 3-phase			
185-225 V △ /320-390VY	H	1	CUL US
200-240 V △ /345-415VY	H	6	CUL US
345-415 V △	H	7	CUL US
单相 1-phase			
115/230 V	V	5	CUL US
230 V	A	1	
60Hz 电压 Voltages at 60 Hz			
3 相 3-phase			
200-240 V △ /345-415VY	H	1	CUL US
220-275 V △ /380-480VY	H	6	CUL US
380-480 V △	H	7	CUL US
575 V △	C	5	CUL US
单相 1-phase			
115/230 V	V	5	CUL US
115 V	B	6	
230 V	A	1	
ATEX 认证 3 相电压 Voltages 3-phase ATEX			
50Hz, 类 3D,3G,3/2D 50Hz, categories 3D,3G,3/2D			
230 V △ /400VY	D	1	
500 V △	D	5	
400 V △ /690VY	D	6	
50Hz, 类 3/2G 50Hz, categories 3/2G			
230 V △ /400VY	D	1	
500 V △	D	5	
400 V △ /690VY	D	6	
60Hz, 类 3D,3G,3/2D 60Hz, categories 3D,3G,3/2D			
460 V △	D	1	
575 V △	D	5	
460 VY	D	6	
60Hz, 类 3/2G 60Hz, categories 3/2G			
460 V △	G	1	
575 V △	G	5	
440 VY	G	6	

脚注:

- 1、表面声强根据 EN216801 在 1 米处的距离测量的, 这时泵被扼至适中的进口压力, 软管连接排气侧, 抽吸侧未装真空卸荷阀。
- 2、针对选型的订购信息, 参看附件一套。阀门的极限压力是以 25°C 的环境温度为基础, 并与冷却介质有关。
- 3、对于 2RB1 943 型, 只有立式安装形式。
- 4、公差: 电机符合 DIN EN 60 034/DIN IEC 34-1 标准, 绝缘等级 F。

三相:

固定电压 +10%
 宽压 +5%
 美国标准 (UL) 和加拿大标准 (CSA) 分别为 10%/+6%

单相:

固定电压 +5%
 在连续工作条件下, 若只有用到最大工作压力的 90%, 那么电压的
 允差可增至 ±10
 美国标准 (UL) 和加拿大标准 (CSA) 分别为 10%/+6%
 频率 ±2%

我们的所有电机符合国际电工委员会标准及所引用的欧洲标准。此标准用以下替换下列成员国的国家标准:

德国 VDE 标准
 法国 NFC 标准
 比利时 NBNC 标准
 英国 Bs 标准
 意大利 CEI 标准
 荷兰 NEN 标准
 瑞典 Ss 标准
 瑞士 SEV 标准

我们的产品也符合很多国家的国家标准。

以下标准也符合 IEC60034-1 标准, 因此相应的电机也可直接在标准条件下使用。

UL 507 美国
 CS A22.2.No.113 加拿大
 IS 325 印度
 IS 4722
 NEK_IEC 60034-1 挪威

Footnotes:

- 1、Measuring surface sound-pressure level acc.to EN 216801,measured at a distance of1 m.The pump is throttled to medium inlet pressure. a hose is connected to the discharge side,and a vacuum-relief valve is not fitted.
- 2、For selection and ordering information,see accessories.The pressure limits of the valves are based on a cooling agent and ambient temperature of 25°C
- 3、For 2RB1 943,only mounting on the end-casing is possible.
- 4、Tolerances:the motors comply with DIN EN60 034/DIN IEC 34-1 and Insulation class F:

Three-phase:

fixed voltages incl.ATEX +10%
 voltage range +5%
 in compliance with UL and CSA 10%/+6%

Single-phases:

Fixed voltages: +5%
 If during continuous operation only 90% of the maximum end pressure is used,the admissible tolerance increases to +/-10%.In compliance with UL and

Frequency:

The motors comply with the IEC and European norms quoted.The European norms replace the national norms of the following member states:Germany (VDE),France(NFC),Belgium(NBNC),Great BRITAIN(BS),Italy(CEI),Nether-lands(NEN),Sweden(SS),Switzerland(SEV)and others.

The machines also comply with various national norms.

The following norms have been adapted to the publications IEC 60 034-1 and the motors can be used at standard rated performance:

UL 1004-1 USA
 CS A22.2.No.113 Canada
 IS 325 India
 IS 4722
 NEK_IEC 60034-1 Norway



■ 温岭东部新区厂房

■ 泽国沈桥厂房

آتور صنعت
ATOORSANAT



内贸部

浙江格凌实业有限公司

地址：浙江省温岭市泽国镇丹崖工业新区

邮编：317523

电话：0576-86465362

传真：0576-86409555

E-mail:greenco@greenco.cn

Http://www.greenco.cn

Export Department

ZHEJIANG GREENCO INDUSTRY CO.,LTD

ADD:danya industrial zone.zeguo.wenling zhejiang China

P.C:317523

Tel:0086-576-86428999

Fax:0086-576-86409555

E-mail:greenco@greenco.cn

Http://www.greenco.cn