

# Sogevac®

## SV40 B - SV65 B - SV100 B

Single-stage, oil-sealed rotary vane pump

Operating instructions GA02315\_002\_03

Ref.:

960x00 to 960x07

960x11 to 960x14

960x16 to 960x19

960x20 to 960x24



	<b>Page</b>
<b>Important Safety Information</b>	<b>3</b>
<b>1 Description</b>	<b>5</b>
1.1 Principle of operation	5
1.2 Technical characteristics	6
1.3 Accessories	10
1.4 Accessories	12
1.5 Spare parts	12
1.6 Lubricants	12
<b>2 Transport and Storing</b>	<b>13</b>
2.1 Transport and packaging	13
2.2 Mounting orientation	13
2.3 Storing	13
<b>3 Installation</b>	<b>14</b>
3.1 Setting up	14
3.2 Connection to system	14
3.3 Electrical connections	15
3.4 Oil filling	16
3.5 Start-up	16
<b>4 Operation</b>	<b>17</b>
4.1 Operation	17
4.2 Switching off / Shutdown	18
<b>5 Maintenance</b>	<b>19</b>
5.1 Safety information	19
5.2 Maintenance Intervals	19
5.3 Oerlikon Leybold Vacuum Service	20
5.4 Maintenance Work	20
<b>6 Troubleshooting</b>	<b>23</b>
<b>7 Spare parts</b>	<b>25</b>
<b>EC Conformance Declaration</b>	<b>38</b>
<b>Declaration of contamination of Compressors, Vacuum Pumps and Components</b>	<b>39</b>

## Important Safety Information

Indicates procedures that must be strictly observed to prevent hazards to persons.

Indicates procedures that must be strictly observed to prevent damage to, or destruction of the product.

Emphasises additional application information and other useful information provided within these Operating Instructions.

The Oerlikon Leybold Vacuum Sogevac® SV40 B - SV65 B - SV100 B has been designed for safe and efficient operation when used properly and in accordance with these Operating Instructions. It is the responsibility of the user to carefully read and strictly observe all safety precautions described in this section and throughout the Operating Instructions. The Sogevac® SV40 B - SV65 B - SV100 B **must only be operated in the proper condition and under the conditions described in the Operating Instructions**. It must be operated and maintained by trained personnel only. Consult local, state, and national agencies regarding specific requirements and regulations. Address any further safety, operation and/or maintenance questions to our nearest office.

### Failure to observe the following precautions could result in serious personal injury!

Sogevac® pumps are not designed:

- for pumping of dusty, aggressive, corrosive, flammable or explosive gases or gases mixtures,
- for pumping of oxygen or other highly reactive gases with a greater concentration than atmospheric concentration (>20%),
- for working in flammable, explosive or dusty environment.

For all these cases, special materials must be used. In case of doubt, please contact Oerlikon Leybold Vacuum.

See also the limits of use indicated in the CE declaration of conformity.

Never expose part of the body to the vacuum. There is a danger of injury. Never operate the pump with an open and thus accessible inlet. Vacuum connections as well as oil filling and oil draining openings must not be opened during operation of the pump.

When operating pump is hot and some surfaces could reach a temperature higher than 80 °C (176 °F). There is a risk of burn by touching.

Depending on the process involved, dangerous substances and oil may escape from the pump. Take the necessary safety precautions!

When working on the pump system always observe the Operating Instructions.

---

### Warning

---

### Caution

---

### Note

---

### Warning



---

## Warning



**Disconnect the unit from the power supply before starting any work.**

---

## Warning



Take appropriate precautions to insure that the pump cannot start.

If the pump has pumped hazardous gases it will be absolutely necessary to determine the nature of the hazard involved and take the appropriate safety precautions.

Observe all safety regulations!

Take adequate safety precautions prior to opening the intake or exhaust port.

---

## Caution

**Failure to observe the following precautions could result in damage to the equipment!**

Liquid and solid particles must not enter the pump. Install the adequate filters, separators and/or condensers. In case of doubt consult Oerlikon Leybold Vacuum.

The intake line of the pump must never be connected to a device with over atmospheric pressure. Design the exhaust line so that no pressure higher than 1,15 bar abs. (0,15 bar rel.) can occur.

Operating of the pump without oil or operating with incorrect direction of rotation can destroy the pump.

---

## Note

Never use discarded seals. Always assemble using new seals.

Respect the instructions concerning environment protection when discarding used oil or exhaust filters!

The pump must be packaged in such a way that it will not be damaged during shipping, and so that no harmful substances can escape from the package.

We reserve the right to alter the design or any data given in these Operating Instructions. The illustrations are not binding.

---

## 1 Description

Sogevac® pumps are designed for pumping of inert gases in the range of rough vacuum, between atmospheric pressure and ultimate pressure of the pump.

When removing condensable vapours, a gas ballast valve must be installed.

### 1.1 Principle of operation

The Sogevac® pumps SV40 B, SV65 B and SV100 B are single-stage oil-sealed rotary vane vacuum pumps.

The rotor, having three slots in which the vanes are sliding, is eccentrically installed in a pump cylinder (stator).

The vanes separate the interior space into 3 chambers. The volume of these chambers varies with the rotation of the rotor.

The gas sucked into the inlet chamber is compressed and then pushed out at the exhaust valve.

The oil injected in the inlet chamber guarantees the air-tightness, the lubrication and cooling of the pump. It is dragged off by the compressed gases and roughly separated by gravity when entering in the oil sump. A fine separation is then operated in the exhaust filter. An internal transfer pushes the collected oil back into the vacuum generator, the transfer is operated by a float valve to avoid atmospheric air coming from the oil casing to the inlet of the pump when no oil is present in the recovery system.

The oil circulation functions by differential pressures.

ATOORSANAT

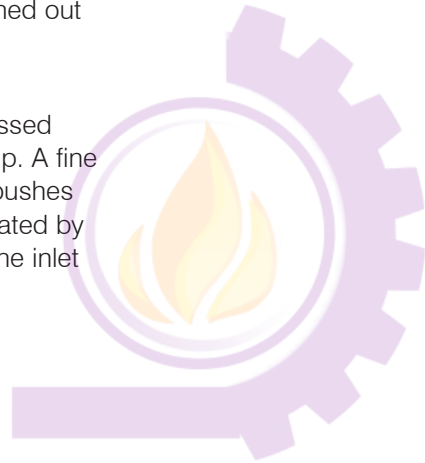

## 1.2 Technical characteristics

### SV40 B

Technical data		50 Hz	60 Hz
Nominal pumping speed	m <sup>3</sup> /h	44	53
Pumping speed (according to PNEUROP)	m <sup>3</sup> /h	38,5	47
Ultimate partial pressure without gas ballast	mbar	≤ 0,5	≤ 0,5
Ultimate total pressure with small gas ballast	mbar	≤ 0,8	≤ 0,8
Ultimate total pressure with standard gas ballast	mbar	≤ 1,5	≤ 1,5
Water vapour tolerance:			
■ with small gas ballast	mbar	10	10
■ with standard gas ballast	mbar	30	30
Water vapour tolerable load:			
■ with small gas ballast	kg.h <sup>-1</sup>	0,28	0,34
■ with standard gas ballast	kg.h <sup>-1</sup>	0,76	0,90
Noise level (according to DIN 46 635)	dB (A)	58	60
Motor power - Rated rotational speed	kW - min <sup>-1</sup>	1,1-1500	1,5-1800
Mains voltage (+/- 10 %)	V	230 / 400	460
Protection - Isolation		IP 55 - F	IP 55 - F
Leak rate	mbar.l.s <sup>-1</sup>	1 x 10 <sup>-3</sup>	1 x 10 <sup>-3</sup>
Oil type / Capacity	l	GS77/1	GS77/1
Intake connection		1 <sup>1/4</sup>	1 <sup>1/4</sup>
Exhaust connection		1 <sup>1/4</sup>	1 <sup>1/4</sup>

### SV65 B

Technical data		50 Hz	60 Hz
Nominal pumping speed	m <sup>3</sup> /h	59	71
Pumping speed (according to PNEUROP)	m <sup>3</sup> /h	54	64
Ultimate partial pressure without gas ballast	mbar	≤ 0,5	≤ 0,5
Ultimate total pressure with small gas ballast	mbar	≤ 0,8	≤ 0,8
Ultimate total pressure with standard gas ballast	mbar	≤ 1,5	≤ 1,5
Water vapour tolerance:			
■ with small gas ballast	mbar	10	10
■ with standard gas ballast	mbar	30	30
Water vapour tolerable load:			
■ with small gas ballast	kg.h <sup>-1</sup>	0,36	0,42
■ with standard gas ballast	kg.h <sup>-1</sup>	1	1,25
Noise level (according to DIN 46 635)	dB (A)	60	64
Motor power - Rated rotational speed	kW - min <sup>-1</sup>	1,5-1500	1,8-1800
Mains voltage (+/- 10 %)	V	230 / 400	460
Protection - Isolation		IP 55 - F	IP 55 - F
Leak rate	mbar.l.s <sup>-1</sup>	1 x 10 <sup>-3</sup>	1 x 10 <sup>-3</sup>
Oil type / Capacity	l	GS77/2	GS77/2
Intake connection		1 <sup>1/4</sup>	1 <sup>1/4</sup>
Exhaust connection		1 <sup>1/4</sup>	1 <sup>1/4</sup>

## SV40 B - SV65 B

SPACE FOR EXHAUST FILTER EXCHANGE AND COOLING

OIL FILTER (OPTION)

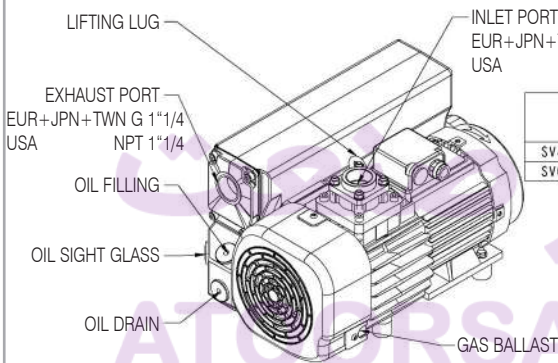
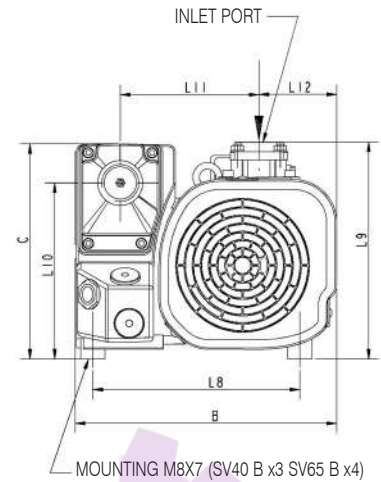
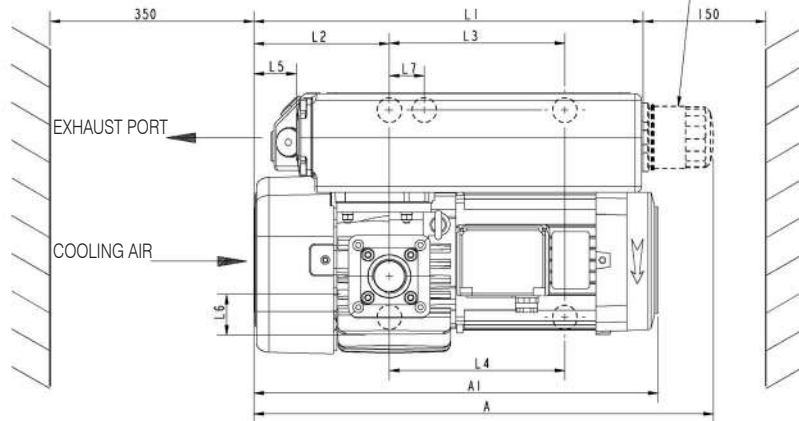

	A	A1	B	C	L1	L2	L3	L4	L5	L6	L7	L8	L9	L10	L11	L12	Weight
SV40 B	510	425	284	265	425	143	-	220	43	46	40	235	255	217	160	74	43 kg
SV65 B	565	480	320	265	480	166	215	215	52	50	0	254	265	217	170	95	49 kg

	A1	L4	Weight
SV40 B US / JPN / TWN	455	226	45 kg
SV65 B US / JPN	480	215	52 kg
SV65 B TWN	480	215	51 kg

### Pumping speeds curves SV40 B - SV65 B

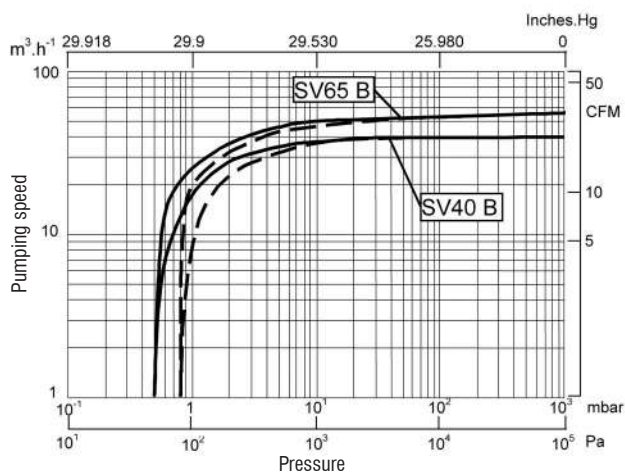

Pumping speed (volume flow rate) — Without gas ballast - - - With gas ballast

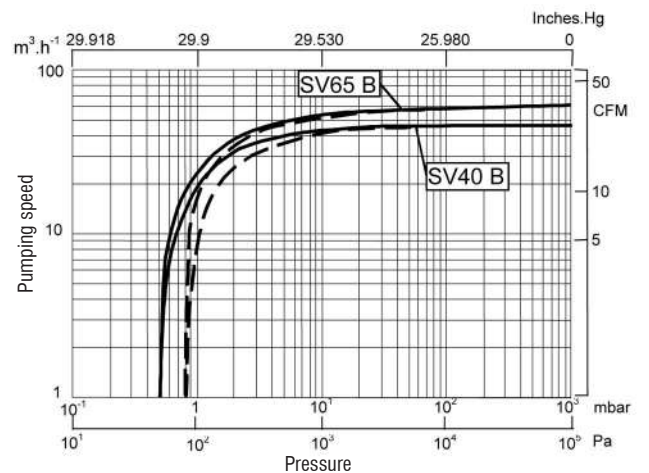

Pumping speed (volume flow rate) — Without gas ballast - - - With gas ballast

fig. 1

## SV100 B

Technical data		50 Hz	60 Hz
Nominal pumping speed	m <sup>3</sup> /h	97,5	117
Pumping speed (according to PNEUROP)	m <sup>3</sup> /h	87,5	105
Ultimate partial pressure without gas ballast	mbar	≤ 0,5	≤ 0,5
Ultimate total pressure with small gas ballast	mbar	≤ 0,8	≤ 0,8
Ultimate total pressure with standard gas ballast	mbar	≤ 1,5	≤ 1,5
Water vapour tolerance:			
■ with small gas ballast	mbar	10	10
■ with standard gas ballast	mbar	30	30
Water vapour tolerable load:			
■ with small gas ballast	kg.h <sup>-1</sup>	0,45	0,60
■ with standard gas ballast	kg.h <sup>-1</sup>	1,60	1,70
Noise level (according to DIN 46 635)	dB (A)	61	64
Motor power - Rated rotational speed	kW - min <sup>-1</sup>	2,2-1500	3,5-1800
Mains voltage (+/- 10 %)	V	230 / 400	460
Protection - Isolation		IP 55 - F	IP 55 - F
Leak rate	mbar.l.s <sup>-1</sup>	1 x 10 <sup>-3</sup>	1 x 10 <sup>-3</sup>
Oil type / Capacity	l	GS77/2	GS77/2
Intake connection		1 <sup>1/4</sup>	1 <sup>1/4</sup>
Exhaust connection		1 <sup>1/4</sup>	1 <sup>1/4</sup>

آتور صنعت  
ATOORSANAT



## SV100 B

SPACE FOR EXHAUST FILTER EXCHANGE AND COOLING

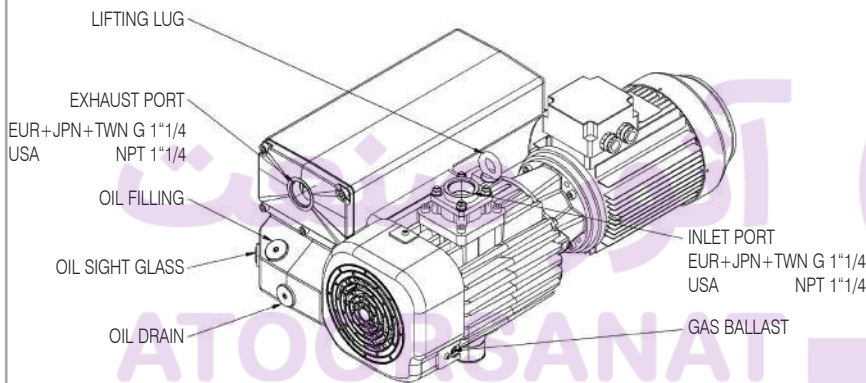
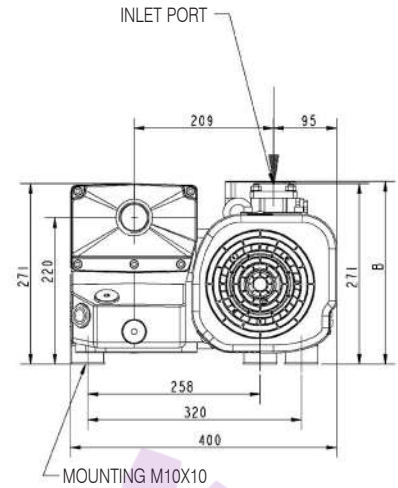
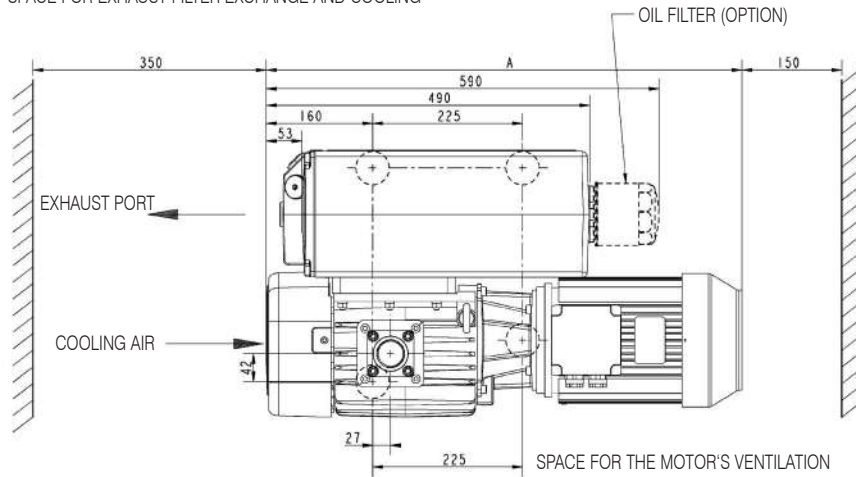

	A	B	Weight
EUR	695	270	75 kg
JPN / TWN	715	275	82 kg
USA	755	290	88 kg

### Pumping speeds curves SV100 B

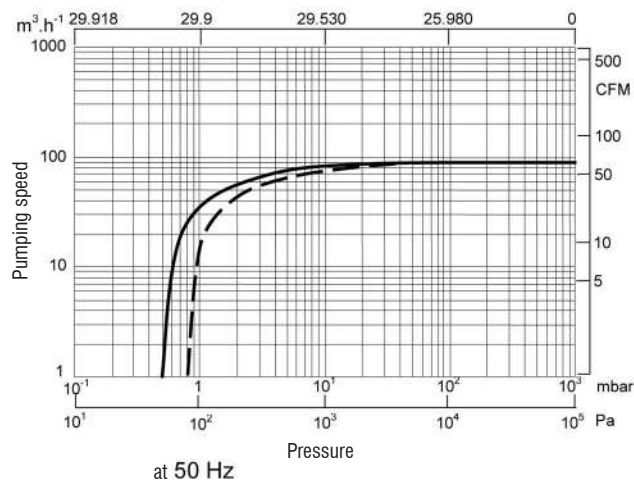

at 50 Hz  
Pumping speed (volume flow rate) — Without gas ballast - - - With gas ballast

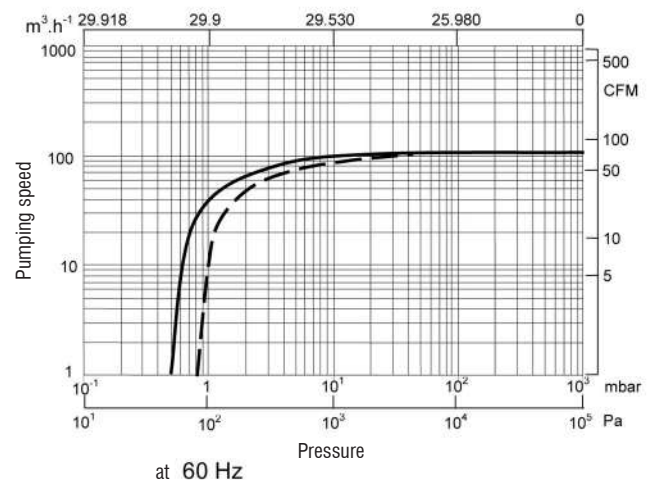

at 60 Hz  
Pumping speed (volume flow rate) — Without gas ballast - - - With gas ballast

fig. 2

## 1.3 Accessories

Item	Specification	Size	Cat. Nr.
1	Union coupling	G1 1/4 M/F	711 18 023
2	Nipple	G1 1/4 M/M	711 18 033
3	Ball valve	G1 1/4 F-F	711 30 105
4	Threaded flange adapter	G1 1/4 M - 40KF	711 18 123
5	Centering ring	40KF	18 328
6	Clamping ring	40KF	18 343
7	Adapter for tubing	G1 1/4 M-DN40	711 18 013
8	Rubber vacuum tubing	Ø10X25	17 203
9	Adapter for tubing	G1 1/4-Ø10X25	711 18 153
10	Adapter	40KF-DN40	711 18 303
11	PVC tubing	DN40 - 1m.	711 18 324
12	TEE reducer bush	G1 1/4 - 1/2 7	711 18 263
13	Right-angle bend 90°	G1 1/4 F-F 7	711 18 213
14	Dust filter paper F40	G1 1/4 M-F	95 155
	Dust filter charcoal F40	G1 1/4 M-F	711 27 102
	Dust filter metal F40	G1 1/4 M-F	711 27 103
	Dust filter polyester F40	G1 1/4 M-F	711 27 104
	Dust filter paper F65-100	G1 1/4 M-F	95 160
	Dust filter charcoal F65-100	G1 1/4 M-F	711 27 112
	Dust filter metal F65-100	G1 1/4 M-F	711 27 113
	Dust filter polyester F65-100	G1 1/4 M-F	711 27 114
15	Vacuum gauge	G1/2 M	95 192
16	Ball valve	G1/2 M/F DN13	711 30 113
17	Threaded flange adapter	G1/2 M - 16KF	711 18 120
18	Regulation valve with isolation valve	G1/2 M	95 187
19	Regulation valve	G1/2 M	95 186
20	Condensate trap SL40	G1 1/4	95 140
21	Condensate trap SL65-100	G1 1/4	95 142

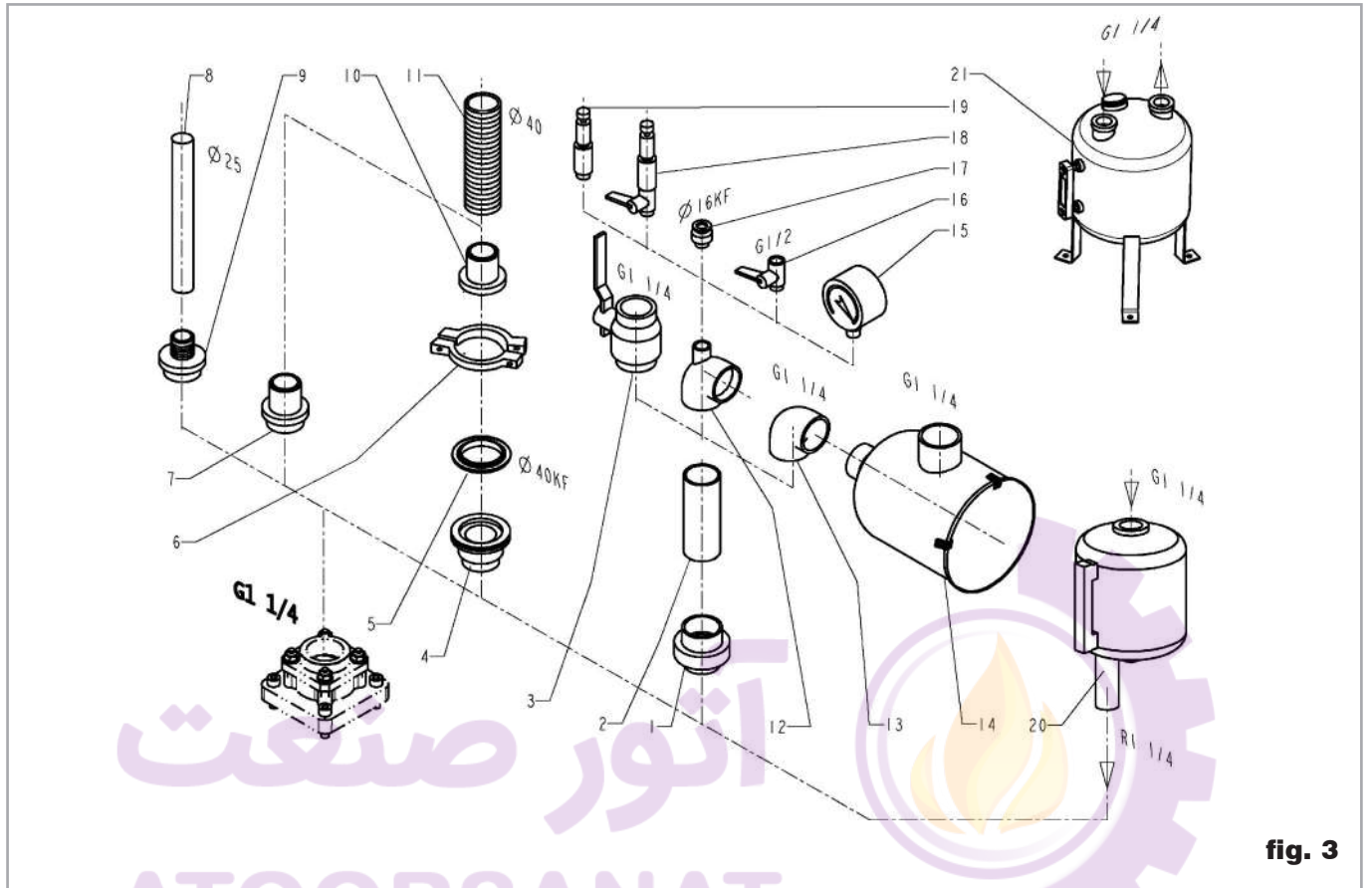

fig. 3



## 1.4 Accessories

	SV40 B	SV65 B	SV100 B
Specification	Cat. Nr.	Cat. Nr.	Cat. Nr.
Oil level switch	711 19 110	711 19 110	711 19 110
Temperature switch	9 714 32 820	9 714 32 830	9 714 32 830
Exhaust filter over pressure switch	9 714 25 890	9 714 25 890	9 714 25 890
Exhaust filter over pressure manometer	95 193	95 193	95 194
Oil drain tap	711 30 114	711 30 114	711 30 114
Roots adapter			9 714 48 740

## 1.5 Spare parts

		SV40 B	SV65 B	SV100 B
Specification	Size	Cat. Nr.	Cat. Nr.	Cat. Nr.
Set of seals	FKM	9 714 27 640	714 20 410	9 714 27 670
Repair set		9 714 27 650	714 20 420	9 714 27 680
Vacuum generator without GB		9 714 28 210	714 22 080	7 714 27 740
Vacuum generator with GB		9 714 28 220	9 714 23 430	9 714 27 750
Service kit		9 714 27 660	9 714 23 440	9 714 27 690
Inlet filter element				
■ paper		710 46 118	712 13 283	712 13 283
■ metal		710 49 083	712 13 324	712 13 324
■ charcoal		710 49 103	712 13 304	712 13 304
■ polyester		712 61 298	712 61 300	712 61 300

## 1.6 Lubricants

The Sogevac® pumps should be run with mineral oils for vacuum pumps with low viscosity according to ISO category VG77. The Oerlikon Leybold Vacuum oil GS77 (He-200 in the US) fulfills these specifications.

GS77 oil: (He-200)	Conditioning	Reference
	2 l	711 17 773
	5 l	711 17 774
	20 l	711 17 775
	200 l	711 17 779

You may use other special lubricants adapted to the applications. Please consult us.

It is required to use a lubricant adapted to the pump application. Please consult us.

Use the oil type indicated on the pump and in the additional operating instructions. In case other oils are used, Oerlikon Leybold Vacuum is not liable and declines warranty claims.

## 2 Transport and Storing

### 2.1 Transport and packaging

Sogevac® vacuum pumps pass a rigorous operating test in our factory and are packaged to avoid transport damages.

Please check packaging on delivery for transport damages.

Packing materials should be disposed off according to environmental laws or re-cycled. These operating instructions are part of the consignment.

The connection ports are blanked off by plastic protective caps or self-adhesives. Take these caps or self-adhesives away before turning on the pump.

For SV40 B and SV65 B, the necessary GS77 oil is supplied in a can beside the pump. For the SV100 B, the GS77 oil is filled in.

### 2.2 Mounting orientation

See required space on drawings in paragraph 1.2.

Pumps which have been filled with oil must only be moved in the upright position (horizontally). Otherwise oil may escape. The angle of slope may not be over 10° max. Avoid any other orientations while moving the pump.

Only use the lifting lugs which are provided on the pump to lift the pump with the specified lifting devices.

Make sure that these have been installed safety. Use suitable lifting equipment. Make sure that all safety regulations are observed.

### 2.3 Storing

Before stocking the pump for a long time put it back in its original condition (blank off inlet and exhaust ports with the shipping seals, drain the oil) and store the pump in a dry place at room temperature.

Until the pump is put back in to service again, the pump should be stored in a dry place, preferably at room temperature (20 °C - 168 °F). Before taking the pump out of service, it should be properly disconnected from the vacuum system, purged with dry nitrogen and the oil should be exchange too. The gas ballast must be closed and if the pump is to be shelved for a longer period of time is should be sealed in a plastic bag together with a desiccant (Silicagel).

If the pump has been shelved for over one year, standard maintenance must be done and the oil must be exchanged too before the pump is put in to service once more.

We recommend that you contact the service from Oerlikon Leybold Vacuum.

---

### Caution

---

# Installation

## Warning



### 3 Installation

It is essential to observe the following instructions step by step to ensure safe start-up. Start-up may only be conducted by trained specialists.

The standard pump is not suitable for installation in explosion hazard areas ATEX. Please contact us, if you are planning such an application. Before installing the pump you must reliably disconnect it from the electrical power supply and prevent the pump from running up inadvertently.

Observe all safety regulations.

#### 3.1 Setting up

The pump must be set up or mounted horizontally on a flat surface. Special mounting is not required.

The following ambient operating environment must be observed:

- Ambient temperature: 12 °C to 40 °C (54 °F to 104 °F),
- Ambient pressure = Atmospheric pressure.

In order to avoid over-heating of the pump, an undisturbed fresh airflow to the pump is necessary.

#### 3.2 Connection to system

The standard pump is not suitable for installation in explosion hazard areas ATEX. Please contact us, when you are planning such an application.

## Caution

### Inlet connection

See safety instructions page 3.

- The inlet flange can be connected with a vacuum-tight flexible hose and/or pipe. The pipes should cause no stresses on the pump's flanges. If necessary, compensators must be installed.
- Restriction of the pipes must be avoided in order not to decrease the pumping speed of the pump. The nominal diameter of the pipes has to be at least the same as the diameter of pump's inlet flange.
- When removing condensable vapours, a gas ballast valve must be installed.
- Inlet pressure must not exceed atmospheric pressure.

### Connection to exhaust side

■ No isolation or restricting devices should be installed in the exhaust line of the pump. If an exhaust line is installed, it must at least have the same diameter as the exhaust flange. It should be installed in a manner so that no condensate can enter the pump (siphon, slope).

The maximum exhaust pressure must neither exceed 1.15 bar absolute (0.15 bar relative), nor fall under atmosphere pressure minus 15 mbar.

## Warning



### 3.3 Electrical connections

Ensure that incoming power to the pump is off before wiring the motor or altering the wiring.

Electrical connection work must only be carried out by a qualified electrician in accordance with the applicable safety rules, see IEC 60204-1.

#### Warning

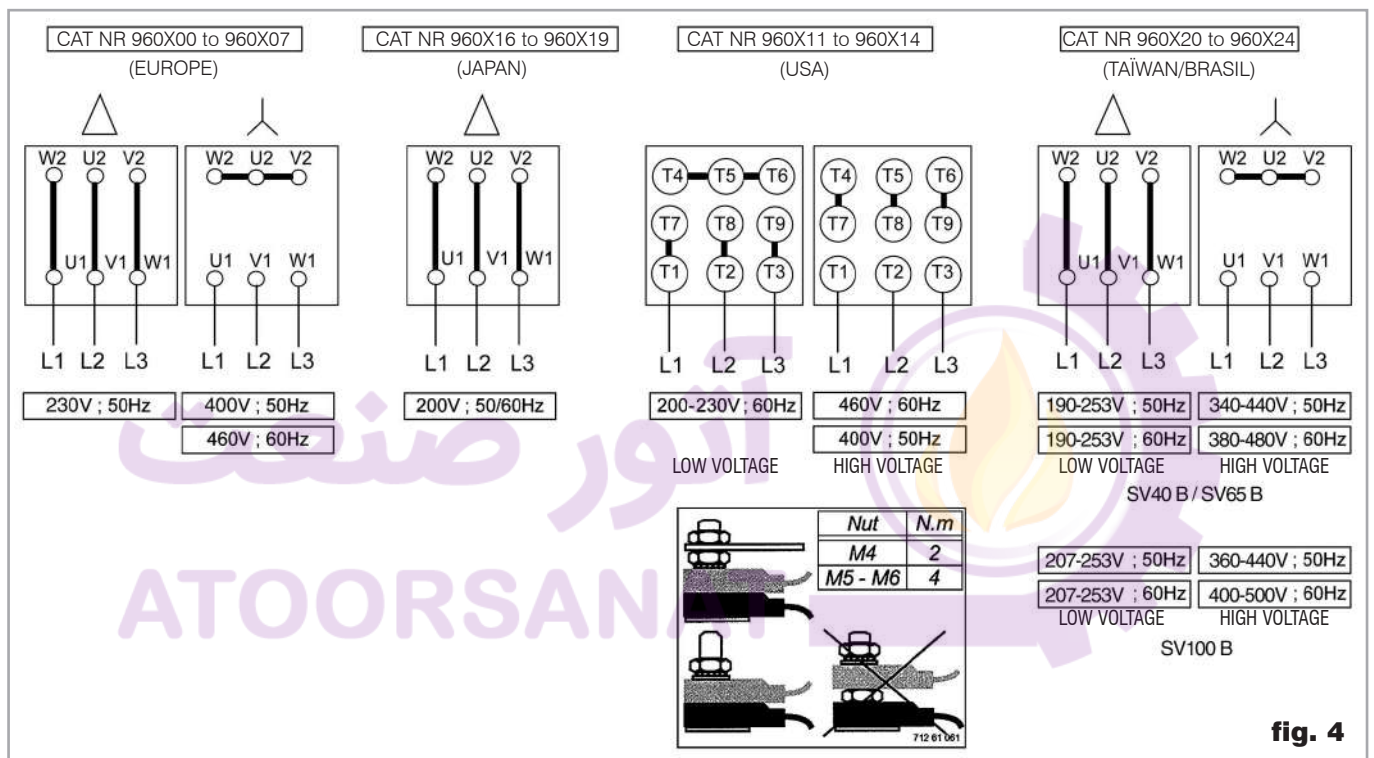

fig. 4

Voltage and frequency mentioned on the motor nameplate must agree with the supply voltage.

To check the direction of rotation of pumps, flick the ON/OFF switch. If the direction of rotation is not identical with the one indicated by the arrow sticking on the motor hood, then inverse any two of the electrical phases in the terminal box. Looking at the motor fan cover, the direction of rotation has to be counterclockwise.

## Motorization

### European versions:

A 50/60 Hz motor is mounted in standard on the SV40 B, SV65 B and SV100 B.

Voltages:

230-400 V  $\pm$ 10% at 50 Hz

460 V  $\pm$ 10% at 60 Hz

### Japan versions:

A JIS 50/60Hz motor is mounted in standard on the SV40 B, SV65 B and SV100 B.

Voltage:

200 V  $\pm$ 10% at 50 Hz and 60 Hz

### US versions:

A NEMA 50/60Hz motor is mounted in standard on the SV40 B, SV65 B and SV100 B.

Voltages:

400 V  $\pm$ 10% at 50 Hz

230 V/460 V  $\pm$ 10% at 60 Hz

### Taiwan / Brasil versions:

A NEMA 50/60Hz motor is mounted in standard on the SV40 B and SV65 B.

Voltage:

230-400 V  $\pm$ 10% at 50 Hz and 230-440 V  $\pm$ 10% at 60 Hz.

SV100B: 230/400 V at 50Hz and 60 Hz.

## Caution

### 3.4 Oil filling

For SV40 B and SV65 B, the necessary oil is supplied in a can beside the pump.

For the SV100 B, the oil is filled in.

To fill in the oil, unscrew the oil fill plug (48 for SV40 B and SV65 B, 52 for SV100 B) and fill in until the oil level reaches the "MAX" mark beside the oil sight glass.

### 3.5 Start-up

The pumps are supplied with the necessary oil filling in ready-to-use condition. Always verify proper oil level before operating the pump.

The pump is designed for fail-safe start-up at temperatures over 12 °C (55 °F) (as per PNEUROPE).

If local regulations provide a WYE-DELTA starting connect the pump to the system so that it can start loadfree, i.e. at atmospheric pressure in the intake port. If the vacuum system is not to be vented further measures will be necessary, e.g. a starting valve can be mounted.

Please contact us in this case.

## Caution

The signals of the oil level switch and exhaust filter over pressure switch must be delayed (timer) on the pump switch-on for approx. 1 minute.



## 4 Operation

### 4.1 Operation

To avoid overloading the motor, do not start the pump more than 6 times within one hour. If more than 6 starts per hour are necessary keep the pump running and mount a valve which opens and closes into the intake line.

Take note of warning labels on the pump.

---

#### Warning



#### Pumping of non-condensable gases

If the pump system contains mainly non condensable gases, the pumps should be operated without gas ballast.

If the composition of the gases to be pumped is not known and if condensation in the pump cannot be ruled out, run the pump with gas ballast valve open in accordance with section below.

#### Pumping of condensable gases and vapors

With the gas ballast valve open and at operating temperature, the Sogevac® pumps can pump pure water vapor up to the values indicated in the Technical Data.

The gas ballast valve is opened by a screwdriver. The running noise of the pump is slightly louder if the gas ballast valve is open. Before pumping vapors ensure that the pump has warmed up for approx. 30 min. with closed intake line and with open gas ballast valve.

Don't open the pump to condensable vapors until it has warmed to operating temperature; pumping process gas with a cold pump results in vapors condensing in the oil.

For processes with a high proportion of condensable vapors, the intake line should be opened only slowly after reaching the operating temperature.

One sign of condensation of vapors in the pump is a rise of the oil level during operation of the pump.

When vapors are pumped, the pump must not be switched off immediately after completion of the process because the condensate dissolved in the pump oil may cause changes or corrosion. To prevent this, the pump must continue to operate with open gas ballast valve and closed intake port until the oil is free of condensate. We recommend operating the pump in this mode for at least 30 min. after completion of the process.

In cycle operation, the pump should not be switched off between the cycles but should continue to run with gas ballast valve open and intake port closed (if possible via a valve). Power consumption is minimal when the pump is operating at ultimate pressure.

Once all vapors have been pumped off from a process (e. g. during drying), the gas ballast valve can be closed in order to improve the ultimate pressure.

---

#### Caution

---



---

#### Caution

---



---

#### Note

---

## 4.2 Switching off / Shutdown

The intake port of the Sogevac® pumps contains an anti-suckback valve which closes the intake port when the pump is switched off, thus maintaining the vacuum in the connected apparatus and preventing oil from being sucked back into the apparatus. The valve's functioning is not impaired by gas ballast operation.

Nevertheless, the anti suck-back valve is not a safety device and it is recommended to install a pilot valve.

If the pump has to be shutdown, drain the oil flush out the pump with fresh oil and fill in the required amount of clean oil (see § 5.4). Close the connection ports. Special preservation or flushing oils do not need to be used.

---

### Caution

---

When the pump has been switched off due to over heating, initiated by the motor or its temperature detector, the pump must be cooled down to the ambient temperature, and must only be switched on again manually after having eliminated the cause.

In order to prevent the pump from running up unexpectedly after a mains power failure, the pump must be integrated in to the control system in such a way that the pump can only be started by a manually operated switch. This applies equally to emergency cut-off switches.

In case of switching processes in connection with a pump which has warmed up under operation conditions, the pump must then not be directly switched on again.

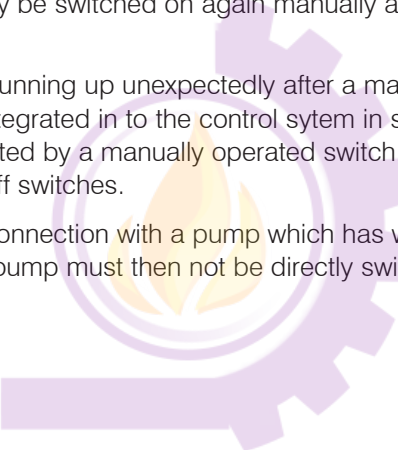
آتور صنعت  
ATOORSANAT 

## 5 Maintenance

### 5.1 Safety Information

Observe all safety regulations.

All work must be done by suitably trained personnel. Maintenance or repairs carried out incorrectly will affect the life and performance of the pump and may cause problems when filing warranty claims.

Never mount used seals; always mount new seals.

### Warning



### Caution

### 5.2 Maintenance Intervals

The intervals stated in the maintenance schedule are approximate values for normal pump operation. Unfavourable ambient conditions and/or aggressive media may significantly reduce the maintenance intervals.

Maintenance job	Frequency	Section
Check the oil level	Daily	A
1st oil change	After 150 h of operation	B
Subsequent oil changes	After 500 to 1500 h of operation or 6 months	B
Replace the oil filter	At each oil change	B
Replace the exhaust filter	If oil mist at exhaust or annually	C
Gas ballast	Monthly	D
Clean the dirt trap	6 months	E
Check the anti-suckback valve	6 months	F
Fan cover cleaning	6 months	G
Electrical connections (only by a specialist)	6 months	

To simplify the maintenance work we recommend combining several jobs.

- Contamination** **5.3 Oerlikon Leybold Vacuum Service**  
Whenever you send us in equipment, indicate whether the equipment is contaminated or is free of substances which could pose a health hazard. If it is contaminated, specify exactly which substances are involved. You must use the form we have prepared for this purpose.
- Formulaire** A copy of the form has been reproduced at the end of these Operating Instructions: "Declaration of Contamination for Compressors, Vacuum Pumps and Components". Another suitable form is available from [www.oerlikon.com](http://www.oerlikon.com) → Oerlikon Leybold Vacuum Systems → Documentation → Download Documents.

Attach the form to the equipment or enclose it with the equipment.

This statement detailing the type of contamination is required to satisfy legal requirements and for the protection of our employees.

We must return to the sender any equipment which is not accompanied by a contamination statement.

---

## Caution

The pump must be packaged in such a way that it will not be damaged during shipping, and so that no harmful substances can escape from the package.

When disposing of used oil, please observe the relevant environmental regulations.

## 5.4 Maintenance Work

### Checking the oil

#### A. Oil level

The pump's oil level during operation must always be between the middle and top edge of the oil-level glass (48 for SV40 B and SV65 B, 52 for SV100 B).

When necessary, switch off the pump and add the correct quantity of oil.

High oil consumption often indicates that exhaust filters are clogged.

The oil level should be checked at least once a day.

#### B. Oil Change, Replacing the Oil Filter (if installed)

Tool required:

- oil filter key (Ref. No. 710 73 532)

Always change the oil when the pump is switched off but still at working temperature.

If there is a risk of the oil being polymerized by the connected process, change the oil immediately after operation of the pump.

Pump when operating is hot and some surfaces could reach a temperature higher than 80 °C (176 °F).

There is a risk of burn by touching. Take note of the warning labels on the pump.

---

## Warning



Unscrew the oil-drain plug (59 for SV40 B and SV65 B, 53 for SV100 B) and let the used oil drain into a suitable container.

### Observe the safety regulations!

When the flow of oil slows down, screw the oil drain plug back in, briefly switch on the pump (max. 10s) and switch it off. Remove the oil drain plug again and drain the remaining oil.

Unscrew the oil filter (39 for SV40 B and SV65 B, 50 for SV100 B). Take a new oil filter, moisten its gasket with oil and screw it in manually.

Reinsert the oil-drain plug.

Unscrew the oil-fill plug (50 for SV40 B and SV65 B, 60 for SV100 B) and fill the pump with fresh oil up to the bottom edge of the oil level glass, run the pump for a short time and then change the oil again.

Use suitable oil only (see Section 1.8).

Depending on the process involved dangerous substances may escape from the pump and oil. Take the appropriate precautions.

### Observe the safety regulations.

Never mount used seals. Always mount new seals.

When disposing of used oil please observe the relevant environmental regulations!

### C. Replacing the exhaust filters

When the exhaust filter elements are clogged, the integrated by-pass opens and the filters are bypassed. Oil mist at the exhaust, and/or high oil consumption are signs that the exhaust filters are clogged.

The exhaust filters must be replaced more often if subjected to increased oil cracking products at high operating temperatures and/or aggressive media.

Oil mist escaping from the exhaust during operation indicates that the filter is probably clogged. Increased energy intake by the motor could also be the result of a soiled exhaust filter.

Open the exhaust hood, take out the filter and replace it.

Also check the gasket of the exhaust flange and change it if necessary.

When disposing of used oil please observe the relevant environmental regulations!

---

#### Caution

---

#### Warning



---

#### Note

---



---

#### Note

---

## **D. Gas ballast valve cleaning**

To clean the gas ballast valve, disassemble the fan cover and the fan. Unscrew the lateral pressure screw, remove the plug and the gas ballast valve by using an appropriate M10 screw screwed in the valve by pulling on the screw.

Clean the membrane, the seat and the RILSAN tube.

Reassemble in the reverse sequence.

## **E. Inlet flange sifter cleaning**

To clean the inlet flange sifter, disconnect the inlet flange and clean the sifter with blast air or an appropriate solvent.

## **F. Anti-suck back valve checking**

The anti-suck back valve should be checked at the same time as the inlet flange sifter and if dirty, be cleaned with an appropriate solvent.

Also check, if there is no damage on the sealing part of the valve.

## **G. Fan cover cleaning**

Soiling of the fan cover may lead to overheating of the motor and the pump.

Put off the cover and clean it with blast air.

Before starting the pump again, be sure that the cover has been reassembled.

## **H. Checking the float valve**

When replacing the exhaust filter, check the cleanliness and the proper operation of the float valve.

After having disassembled the exhaust flange, remove the centering pin, pull on the float valve, clean the nozzle and check that the float itself oscillates free around its axle and that the valve is tight.

Clean the float chamber of the oil casing.

Reassemble in the reverse sequence.

## 6 Troubleshooting

Fault	Possible cause	Remedy	Reference section *
Pump does not start.	Pump is connected incorrectly.	Connect the pump correctly.	3.3
	Motor protection switch incorrectly set.	Set motor protection switch properly.	3.3
Pump does not reach ultimate pressure.	Operating voltage does not match motor.	Replace the motor.	1.8
	Motor is malfunctioning.	Replace the motor.	
	Oil temperature is below 12 °C (54 °F).	Heat the pump and pump oil or use different oil.	5.4-B
	Oil is too viscous.	Use appropriate oil grade.	3.4-C
Pumping speed is too low.	Exhaust filter / exhaust line is clogged.	Replace the filter or clean the exhaust line.	5.4-H
	External leak.	Repair the pump.	
	Float valve does not close.	Repair the valve.	5.4-F
	Anti-suckback valve is malfunctioning.	Repair the valve.	5.4-B
	Inadequate lubrication due to:	Change the oil (degas it, if necessary).	
	■ unsuitable or contaminated oil,	Replace the oil filter.	5.4-B
	■ clogged oil filter,	Clean the oil casing.	5.4-C
	■ clogged oil lines.	Clean vacuum lines.	
	Vacuum lines are dirty.	Check the process date; replace the pump, if necessary.	5.4-E/1.2/3.2
	Pump is too small.	Clean the dirt trap;	
After switching off pump under vacuum, pressure in system rises too fast.	Dirt trap in the intake port is clogged.	Precaution: install a dust filter in intake line.	5.4-C
	Exhaust filter is clogged.	Install new filter elements.	
	Connecting lines are too narrow or too long.	Use adequately wide and short connecting lines.	3.2
Pump gets too hot.	Anti-suckback valve is hard to open.	Check spring free length.	5.4-F
	System has a leak.	Check the system.	
Pump gets too hot.	Anti-suckback is malfunctioning.	Repair the valve.	3.1
	Cooling air supply is obstructed.	Set pump up correctly.	
	Cooler is dirty.	Clean the cooler.	3.1
	Ambient temperature is too high.	Set pump up correctly.	
	Process gas is too hot.	Change the process.	5.4-B
	Oil level is too low.	Add oil to reach the correct oil level.	
	Oil is unsuitable.	Change the oil.	5.4-B
	Oil cycle is obstructed.	Clean or repair the oil lines.	5.4-C
Exhaust filter / exhaust line is obstructed.	Replace the exhaust filter, clean the exhaust line.		

# Troubleshooting

Fault	Possible cause	Remedy	Reference section *
Oil in intake line or in vacuum vessel.	Oil comes from the vacuum system.	Check the vacuum system.	
	Anti-suckback valve is obstructed.	Clean or repair the valve.	5.4-F
	Sealing surfaces of anti-suckback valve are damaged or dirty.	Clean or repair the intake port and valve.	5.4-F
Pump's oil consumption too high, oil mist at exhaust.	Oil level is too high.	Drain the excess oil.	5.4-B
	Exhaust filters are clogged or damaged.	Replace the filters.	5.4-C
	Nozzle of float valve is clogged.	Check the valve, clean the nozzle.	5.4-I
Oil is turbid.	Condensation.	Drain the excess oil.	
		Degas the oil or change the oil and clean the pump. Precaution: open the gas ballast valve or insert a condensate trap. Clean the gas ballast intake filter.	4.1/5.4-B 5.4-G
Pump is excessively noisy.	Oil level is very low (oil is no longer visible).	Add oil.	5.4-B
	Oil filter is clogged.	Change the oil and filter.	5.4-B
	Large vacuum leak in system.	Repair vacuum leak.	Contact Oerlikon Leybold Vacuum.

\* Reference section: This column refers to the section in the Operating Instructions that contains the applicable repair information.

Never mount used seals. Always mount new seals.

آتور صنعت  
ATOORSANAT





## 7 Spare parts

To guarantee safe operation of the Oerlikon Leybold Vacuum vacuum pump, only original spare parts and accessories should be used. When ordering spare parts and accessories, always state pump type and serial number. You can find part numbers in the spare parts list.

Consummables and main spare parts kits for Sogevac® pumps are usually available on stock at Oerlikon Leybold Vacuum's service centers. The list of these parts is given here after and in the spare parts table where the contents of each kits is detailed.

- Oil filter (on some models)
- Exhaust demisters
- Oil GS 77 (Special oils please refer to the specific notice of the pump or contact Oerlikon Leybold Vacuum)
- Service kit
- Set of seals
- Repair kit
- Vacuum generator without GB
- Vacuum generator with GB

We recommend to use these kits which have been defined to allow an optimal maintenance or repair. Individual spare parts may need longer delivery time.

آتور صنعت  
ATOORSANAT



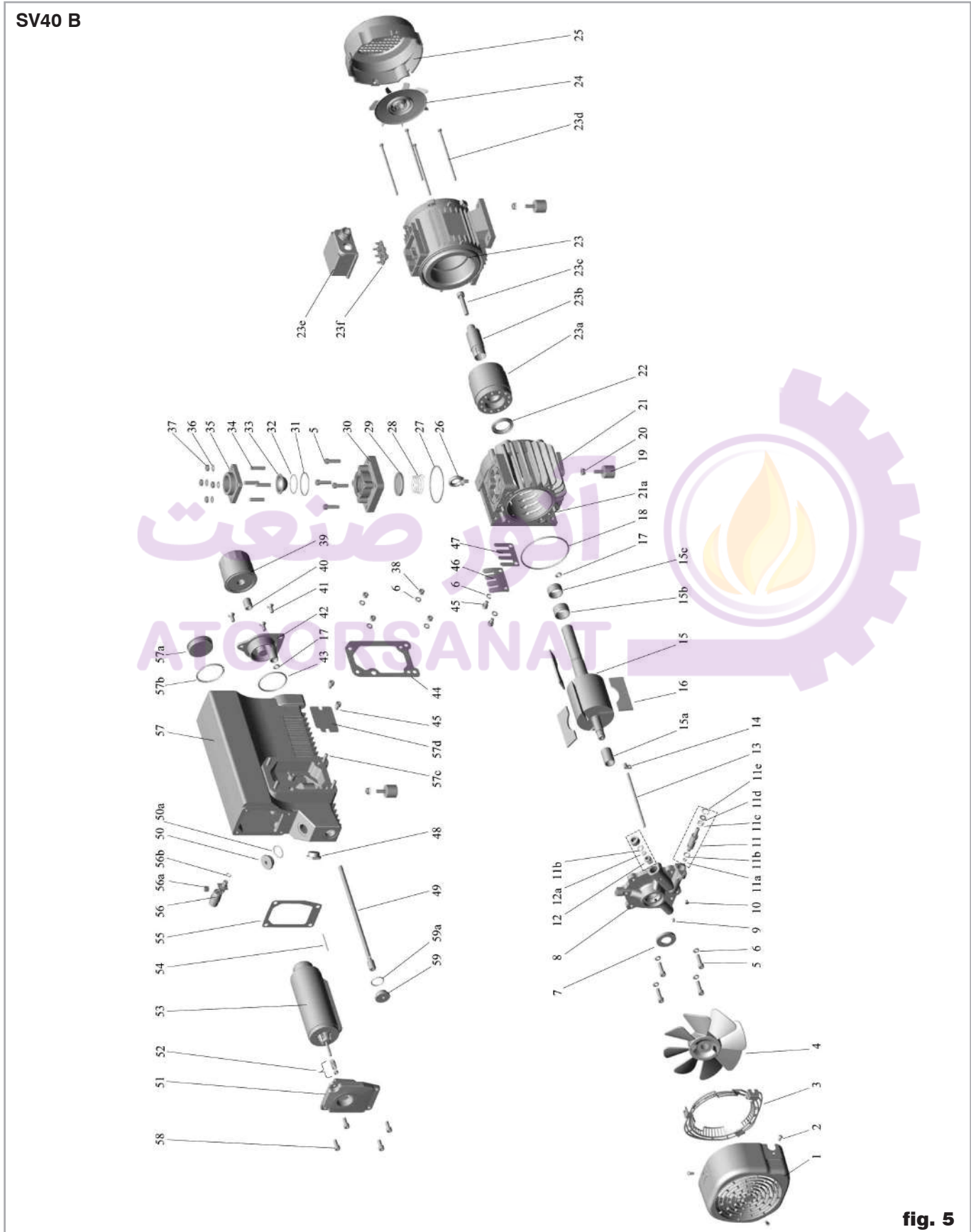

fig. 5

Pos.	Qty	Specification	Dimensions (mm)	Material	Ref, No,	Notes	714 20 410	714 20 420	714 20 80	9 714 23 430	9 714 23 440
1	1	MODULE COVER			971424850						
2	3	SCREW	HC M6X12		V3815407						
3	1	PROTECTIVE COVER			971424860						
4	1	TURBINE			971424870						
5	8	SCREW	CHC M8 X 30 Q8.8		V3811517				●	●	
6	10	WASHER	W8		V3600524						
7	1	RADIAL SHAFT SEAL	25/47X6	FKM	71421000		●		●	●	
8	1	END PLATE WITHOUT GB			971424660				●		
8	1	END PLATE WITH GB			71420450	Incl.11, 12, 13, 14				●	
9	1	SCREW	HC M6X10 Q8.8		V3821415						
10	1	SCREW	M6		971424710						
11	1	GAS BALLAST VALVE			971424450	Incl. 10, 11a, b, c, d, e					
11a	1	O-RING	4.42 X 2.62	FKM	971424460		●				
11b	2	O-RING	10.77 X 2.62	FKM	71237320		●				
11c	1	SPRING			71417990						
11d	1	WASHER	M8		V3600501						
11e	1	LOCKING RING	D18 type 7000		V0800012						
12	1	GAS BALLAST			71417050	Incl. 9, 11b, 12a					
12	1	GAS BALLAST			71418710	Incl. 9, 11b, 12a					
12a	1	MEMBRAN	D12 X 2 70SH	FKM	71417060		●				
13	1	RILSAN TUBE	D4/6 LG165		971424360					●	
14	1	CLAMPING RING	DN8		971424370					●	
15	1	ROTOR WITH RINGS			71420760	Incl. 15a, b, c				●	●
15a	1	ROTOR RING	DN20/25X38.5		71421170			●			
15b	1	ROTOR RING	DN32/37X20		971424900			●			
15c	1	ROTOR RING	DN30/35X17		71420790			●			
16	1	VANE SET OF 3			71420810			●	●	●	
17	2	O-RING	9.12 X 3.53	FKM	71417260		●				
18	1	O-RING	110.72X3.53	FKM	71237440		●				
19	3	RUBBER MOUNT	DN30 H25		71212640						
20	4	HEXAGON FLANGE NUT	H M8		V1507500						
21	1	PUMP CYLINDER			71420400	Incl. 21a				●	●
21a	2	CENTERING PIN	DN8 L32		71233890					●	●
22	1	RADIAL SHAFT SEAL	35/52X6	FKM	71420820		●		●	●	
23	1	MOTOR EUR.	1.1kW 50Hz 230/400V		71421130	Incl. 23a, b, c, d, e, f, 24, 25					
23a	1	ELECTRICAL ROTOR	1.3kW 60Hz 460V		971424230						
23b	1	MOTOR RING			71421150						
23c	1	SCREW	CHC M10 X 55 Q8.8		V3811627						
23d	1	TIE ROD (SET OF 4) EUR			71420560						
23e	1	TERMINAL BOX			971422840						
23f	1	TERMINAL BOARD			971422860						
23	1	MOTOR USA	2 HP 60Hz 230/460V		71421160	Incl. 23a, b, c, d, e, 24, 25					
23a	1	ELECTRICAL ROTOR	2 HP 50Hz 400V		971424240						
23b	1	MOTOR RING			71421140						
23c	1	SCREW	CHC M10 X 80 Q8.8		V3811637						
23d	1	TIE ROD (SET OF 4)			71416800						
23e	1	TERMINAL BOX			971422900						
23	1	MOTOR JAPAN	1.5 kW 50/60Hz 200V		71421250	Incl. 23a, b, c, d, e, 24, 25					
23a	1	ELECTRICAL ROTOR			971424240						
23b	1	MOTOR RING			71421140						
23c	1	SCREW	CHC M10 X 80 Q8.8		V3811637						
23d	1	TIE ROD (SET OF 4)			71416800						
23e	1	TERMINAL BOX			971422840						
23f	1	TERMINAL BOARD			971422860						
23	1	MOTOR TAIWAN / BRASIL	1.3 kW 50Hz 190/440V		71421240	Incl. 23a, b, c, d, e, f, 24, 25					
23a	1	ELECTRICAL ROTOR	1.3 kW 60Hz 190/480V		971424240						
23b	1	MOTOR RING			71421140						
23c	1	SCREW	CHC M10 X 80 Q8.8		V3811637						
23d	1	TIE ROD (SET OF 4)			71416800						
23e	1	TERMINAL BOX			971422840						
23f	1	TERMINAL BOARD			971422860						

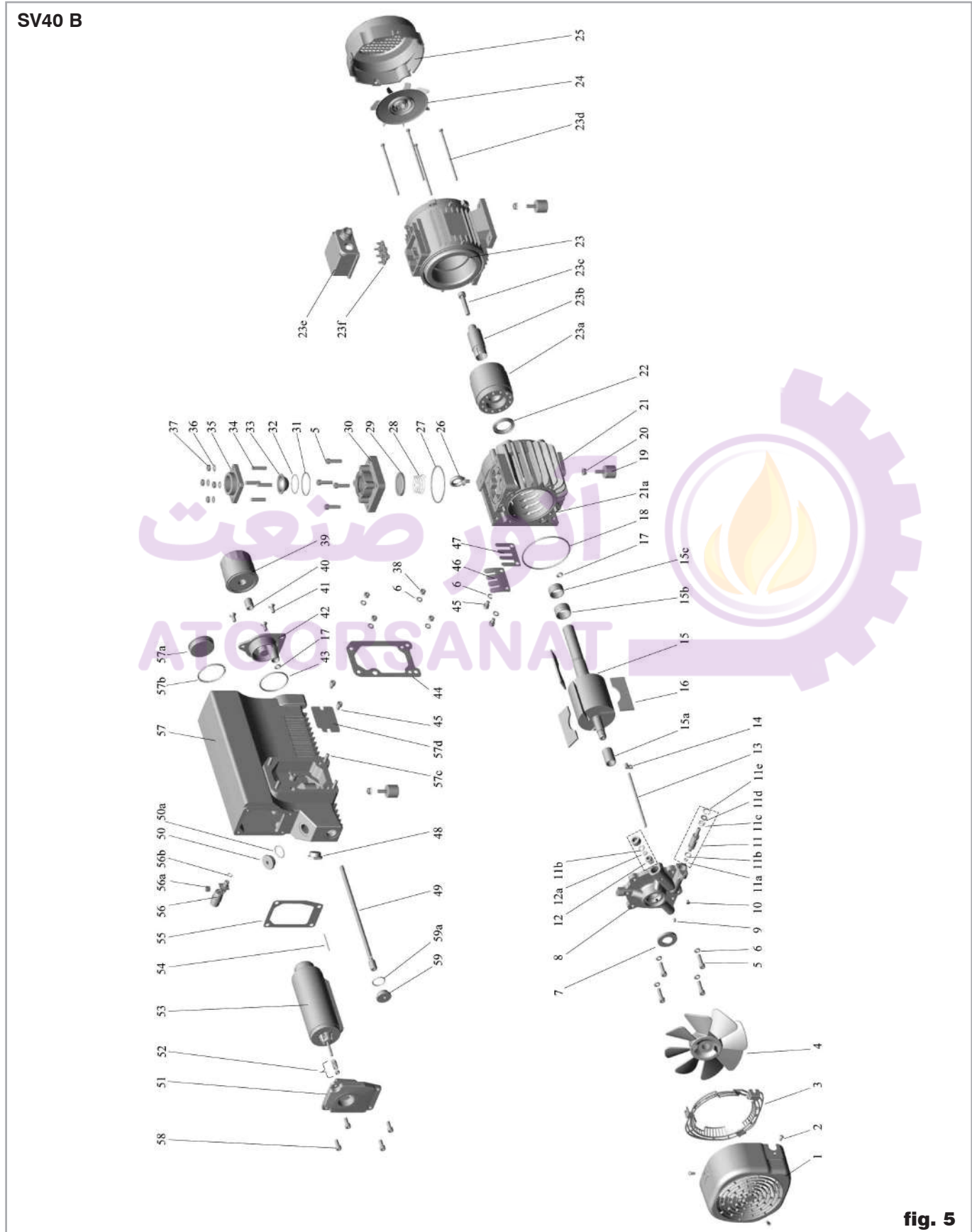
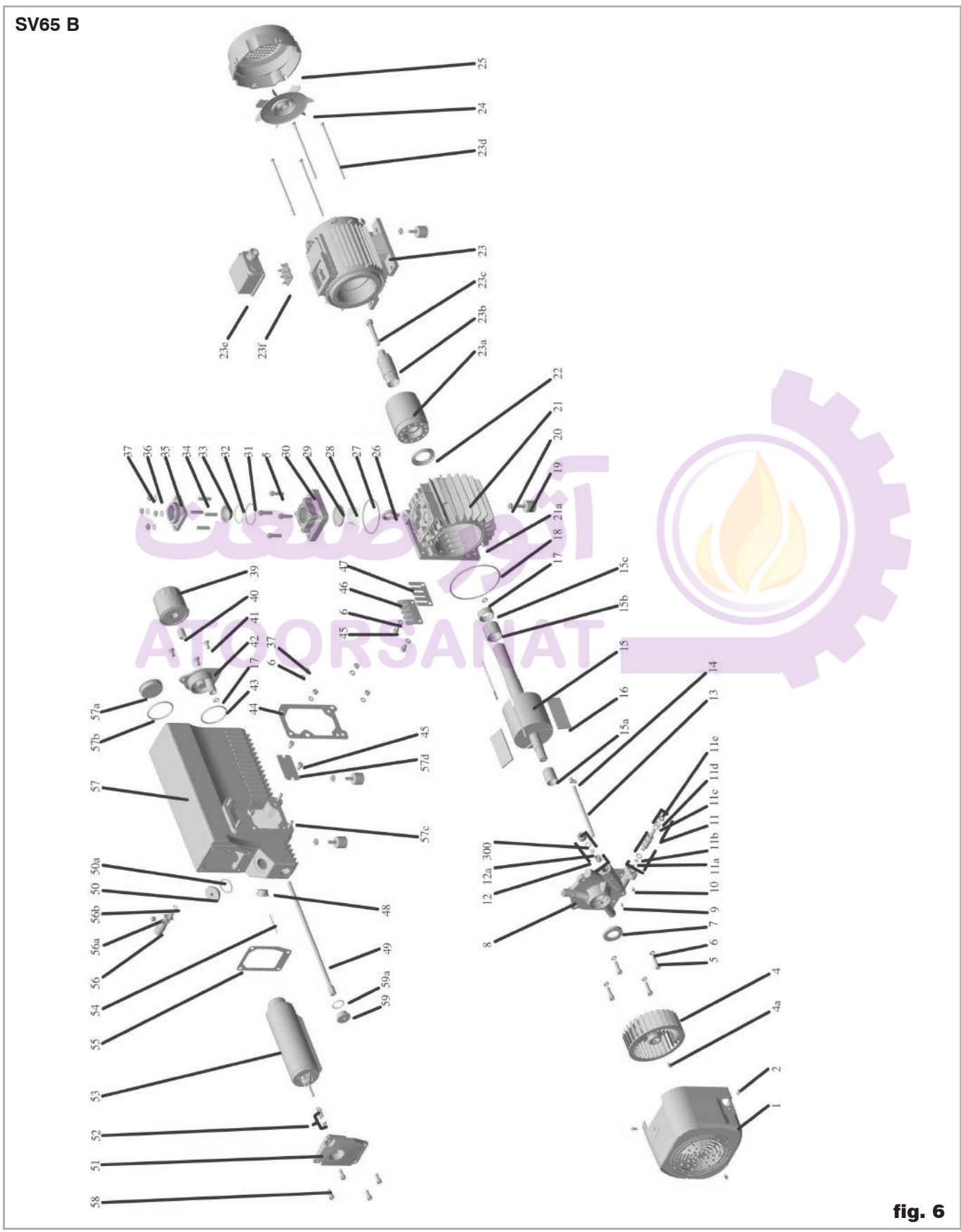

fig. 5

Pos.	Qty	Specification	Dimensions (mm)	Material	Ref, No,	Notes	714 20 410	714 20 420	714 20 80	9 714 23 430	9 714 23 440
24	1	FAN MOTOR			71416840						
25	1	FAN COVER MOTOR			71416830						
26	1	LIFTING LUG	M8		71402970						
27	1	O-RING	82.14X3.53	FKM	71421340		●				
28	1	SPRING			71212400						
29	1	INTAKE VALVE		FKM	71015460		●				
30	1	INTAKE FLANGE			71416640						
31	1	O-RING	50X3	FKM	71217660		●				
32	1	O-RING	42X2	FKM	71237130		●				
33	1	FILTER	DN45		71407290						
34	4	LOCKING SCREW	M8-25/15J=12 Q6.8		V2100425						
35	1	INTAKE FLANGE	G1 ¼		71416650	USA					
35	1	INTAKE FLANGE	NPT 1 ¼		71417390	USA					
36	4	WASHER	Z8		V3600513						
37	8	NUT	H M8 Q6		V1500501						
39	1	OIL FILTER			71420980			●			
40	1	NIPPLE	¾ 16 UNF 2A		71417150						
41	4	SCREW	FHc M8X20		V3817407						
42	1	OIL FILTER HOLDER			71418960	Incl. 40					
43	1	O-RING	63.09 X 3.53	FKM	71417330		●				
44	1	FLAT GASKET			71420750		●				
45	4	SCREW	CHC M8X12 Q8.8		V3811507			●	●	●	●
46	1	VALVE STOP			71420840			●	●	●	●
47	1	VALVE			71420830			●	●	●	●
48	1	OIL LEVEL GLASS	G3/4		71219480			●			
49	1	OIL RECOVERY PIPE			71420970						
50	1	PLUG + O-RING	G 1		71073040	Incl. 50a					
50a	1	O-RING	33 X 3.5	FKM	71217410		●				●
51	1	EXHAUST FLANGE	G1 ¼		71420440						
51	1	EXHAUST FLANGE	NPT 1 ¼		71422000	USA					
52	1	SPRING UNIT			71420370			●			●
53	1	EXHAUST FILTER			71421180			●			●
54	1	CENTERING PIN	DN2.5		971427110						
55	1	FLAT GASKET		FKM	71420740		●				●
56	1	FLOAT COMPL.			71417210	Incl. 56a, b					
56a	1	OIL RETURN VALVE SEAL			71212500		●				
56b	1	O-RING	8X2	FKM	71217650		●				
57	1	OIL CASING WITH OIL FILTER			71420910	Incl. 45, 57a, b, c, d					
57	1	OIL CASING WITHOUT OIL FILTER			71421260	Incl. 45, 57a, b, c, d					
57a	2	PLUG + GASKET	G 2		71212650	Incl. 57b					
57b	2	O-RING	56 X2.5	FKM	71217980		●				
57c	4	LOCKING SCREW M8X25	M8 25-16/J=16		V2113426						
57d	1	GRID			71421230						
58	4	SCREW	CHC M8X12		V3811513						
59	1	PLUG + O-RING	G ¾		71256380	Incl. 59a					
59a	1	O-RING	27 X 2.5	FKM	71217580		●				●
		SET OF SEALS		FKM	971427640						▲
		REPAIR KIT			971427650						▲
		VACUUM GENERATOR WITHOUT GB			971428210						▲
		VACUUM GENERATOR WITH GB			971428220						▲
		SERVICE KIT			971427660						▲

# Spare parts



**fig. 6**

Pos.	Qty	Specification	Dimensions (mm)	Material	Ref. No,	Notes	714 20 410	714 20 420	714 20 80	9 714 23 430	9 714 23 440
1	1	MODULE COVER			71417020						
2	3	SCREW	HC M6X12		V3815407						
3	1	PROTECTIVE COVER			71417030						
4	1	TURBINE			71417080						
4a	1	SCREW	H M6 X 15		71257660						
5	8	SCREW	CHC M8X30 Q8.8		V3811517						
6	10	WASHER	W8	FKM	V3600524						
7	1	RADIAL SHAFT SEAL	30/52X7		71417570						
8	1	END PLATE WITHOUT GB			71421970						
8	1	END PLATE WITH GB			971423420	Incl.11,12,13,14					
9	1	SCREW	HC M6X10 Q8.8		V3821415						
10	1	SCREW	M6		971424710						
11	1	GAS BALLAST VALVE			971424450	Incl. 10,11a,b,c,d,e					
11a	1	O-RING	4.42 X 2.62	FKM	971424460						
11b	2	O-RING	10.77 X 2.62	FKM	71237320						
11c	1	SPRING			71417990						
11d	1	WASHER	M8		V3600501						
11e	1	LOCKING RING	D18 type 7000		V0800012						
12	1	GAS BALLAST 1.1m3/h			71417050	Incl. 9, 11b, 12a					
12	1	GAS BALLAST 3.5m3/h			71418710	Incl. 9, 11b, 12a					
12a	1	MEMBRAN	D12 X 2 70SH	FKM	71417060						
13	1	RILSAN TUBE	D5.5/8 LG165		71418040						
14	1	CLAMPING RING	DN8		71418050						
15	1	ROTOR WITH RINGS			71417400	Incl. 15a, b, c					
15a	1	ROTOR RING	DN25/30X38.5		71416860						
15b	1	ROTOR RING	DN35/42X36		71421700						
15c	1	ROTOR RING	DN35/40X17		71418310						
16	1	VANE SET OF 3			71416750						
17	2	O-RING	9.12 X 3.53	FKM	71417260						
18	1	O-RING	126.59X3.53	FKM	71417240						
19	4	RUBBER MOUNT	DN30 H25		71212640						
20	4	HEXAGON FLANGE NUT	H M8		V1507500						
21	1	PUMP CYLINDER			71416600	Incl. 21a					
21a	2	CENTERING PIN	DN8 L32		71233890						
22	1	RADIAL SHAFT SEAL	40/62X6	FKM	71417010						
23	1	MOTOR EUR.	1.5kW 50Hz 230/400V		71419820	Incl. 23a, b, c, d, e, f, 24, 25					
23a	1	ELECTRICAL ROTOR	1.8kW 60Hz 460V		71416820						
23b	1	MOTOR RING			71416880						
23e	1	TERMINAL BOX			971422840						
23f	1	TERMINAL BOARD			971422860						
23	1	MOTOR USA	3 HP 60Hz 230/460V		71419970	Incl. 23a, b, c, d, e, 24, 25					
23a	1	ELECTRICAL ROTOR	3 HP 50Hz 400V		71416910						
23b	1	MOTOR RING			71416770						
23f	1	TERMINAL BOARD			971422900						
23	1	MOTOR JAPAN	2.2 kW 50/60Hz 200V		71422120	Incl. 23a, b, c, d, e, f, 24, 25					
23a	1	ELECTRICAL ROTOR			71416910						
23b	1	MOTOR RING			71416770						
23e	1	TERMINAL BOX			971422840						
23f	1	TERMINAL BOARD			971422860						
23	1	MOTOR TAIWAN / BRASIL	1.8 kW 50Hz 190/440V		71422130	Incl. 23a, b, c, d, e, f, 24, 25					
23a	1	ELECTRICAL ROTOR	1.8 kW 60Hz 190/480V		71416970						
23b	1	MOTOR RING			71416760						
23c	1	SCREW	CHC M8 X 70 Q8.8		V3811633						
23d	1	TIE ROD (SET OF 4)			71416800						
23e	1	TERMINAL BOX			971422840						
23f	1	TERMINAL BOARD			971422860						

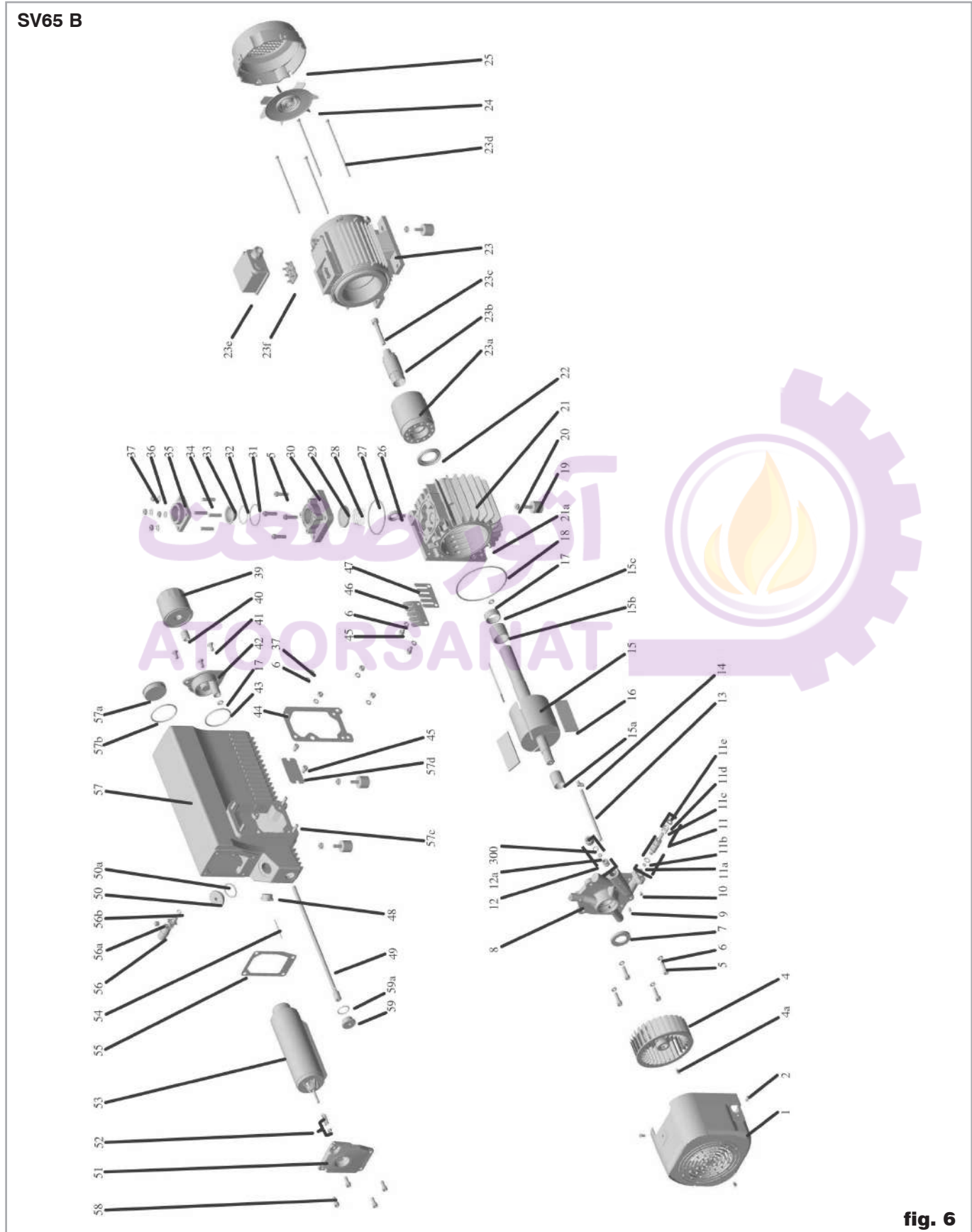

fig. 6



Pos.	Qty	Specification	Dimensions (mm)	Material	Ref, No,	Notes	714 20 410	714 20 420	714 20 80	9 714 23 430	9 714 23 440
24	1	FAN MOTOR			71416840						
25	1	FAN COVER MOTOR			71416830						
26	1	LIFTING LUG	M8		71402970						
27	1	O-RING	82.14X3.53	FKM	71421340		●				
28	1	SPRING			71212400						
29	1	INTAKE VALVE		FKM	71015460		●				
30	1	INTAKE FLANGE			71416640						
31	1	O-RING	50X3	FKM	71217660		●				
32	1	O-RING	42X2	FKM	71237130		●				
33	1	FILTER	DN45		71407290						
34	4	LOCKING SCREW	M8-25/15J=12 Q6.8		V2100425						
35	1	INTAKE FLANGE	G1 1/4		71416650	USA					
35	1	INTAKE FLANGE	NPT 1 1/4		71417390	USA					
36	4	WASHER	Z8		V3600513						
37	8	NUT	H M8 Q6		V1500501						
39	1	OIL FILTER			71420980			●			
40	1	NIPPLE	3/4 16 UNF 2A		71417150						
41	4	SCREW	FHc M8X20		V3817407						
42	1	OIL FILTER HOLDER			71418960	Incl. 40					
43	1	O-RING	63.09 X 3.53	FKM	71417330		●				
44	1	FLAT GASKET			71416730		●				
45	4	SCREW	CHC M8X12 Q8.8		V3811507			●	●	●	●
46	1	VALVE STOP			71417100			●	●	●	●
47	1	VALVE			71417090			●	●	●	●
48	1	OIL LEVEL GLASS	G3/4		71219480		●				
49	1	OIL RECOVERY PIPE			71417130						
50	1	PLUG + O-RING	G 1		71073040	Incl. 50a					
50a	1	O-RING	33 X 3.5	FKM	71217410		●				●
51	1	EXHAUST FLANGE	G1 1/4		71420440						
51	1	EXHAUST FLANGE	NPT 1 1/4		71422000	USA					
52	1	SPRING UNIT			71420370			●			●
53	1	EXHAUST FILTER			71417300			●			●
54	1	CENTERING PIN	DN2.5		971427110						
55	1	FLAT GASKET		FKM	71420360		●				●
56	1	FLOAT COMPL.			71417210	Incl. 56a, b					
56a	1	OIL RETURN VALVE SEAL			71212500		●				
56b	1	O-RING	8X2	FKM	71217650		●				
57	1	OIL CASING WITH OIL FILTER			71419790	Incl. 45, 57a, b, c, d					
57	1	OIL CASING WITHOUT OIL FILTER			71419830	Incl. 45, 57a, b, c, d					
57a	2	PLUG + GASKET	G 2		71212650	Incl. 57b					
57b	1	O-RING	56 X2.5	FKM	71217980		●				
57c	4	LOCKING SCREW M8X25	M8 25-16/J=16		V2113426						
57d	1	GRID			71417170						
58	4	SCREW	CHC M8X20		V3811513						
59	1	PLUG + O-RING	G 3/4		71256380	Incl. 59a					
59a	1	O-RING	27 X 2.5	FKM	71217580		●				●
		SET OF SEALS		FKM	71420410						▲
		REPAIR KIT			71420420						▲
		VACUUM GENERATOR WITHOUT GB			71422080						▲
		VACUUM GENERATOR WITH GB			971423430						▲
		SERVICE KIT			971423440						▲

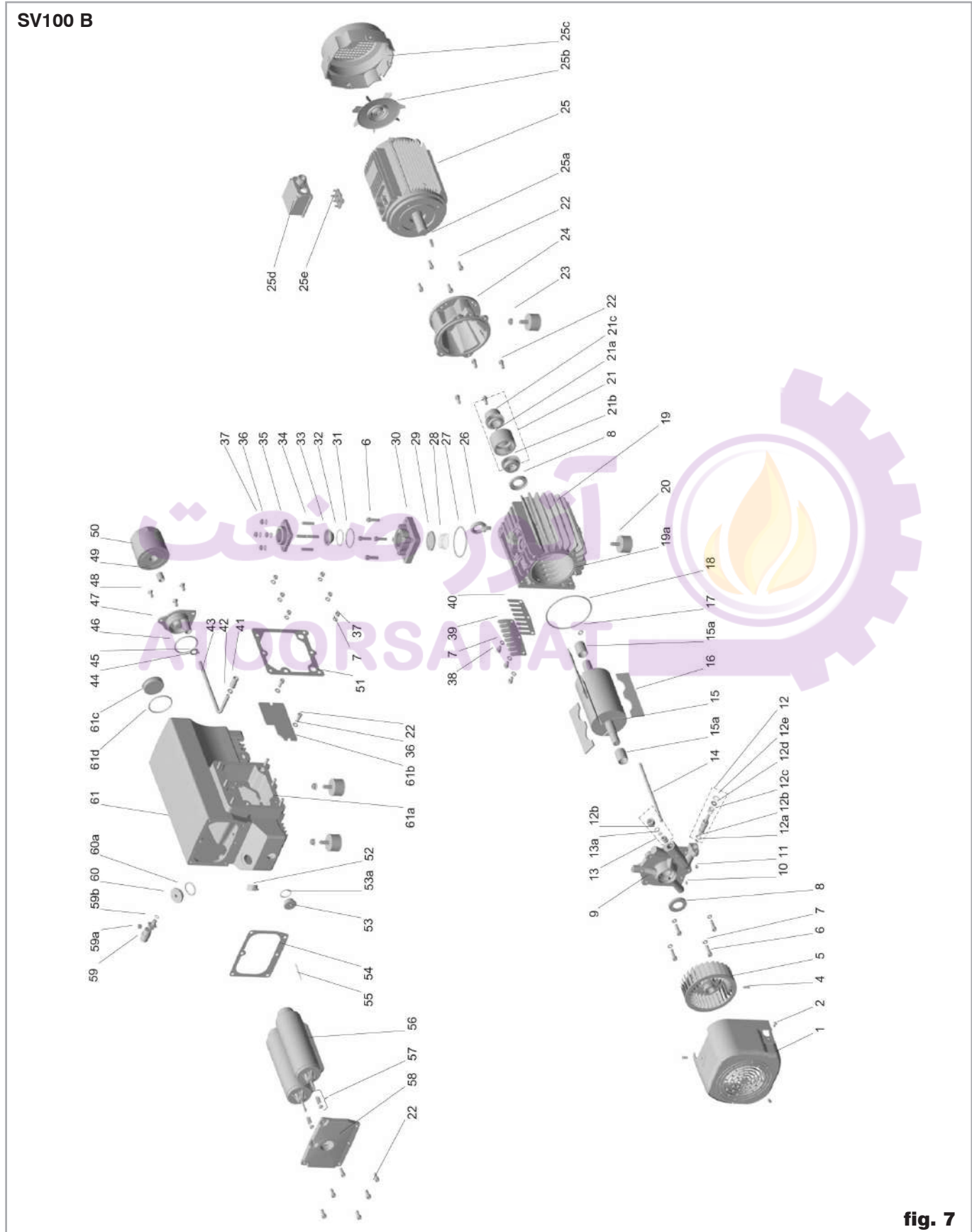

fig. 7

Pos.	Qty	Specification	Dimensions (mm)	Material	Ref, No,	Notes	714 20 410	714 20 420	714 20 80	9 714 23 430	9 714 23 440
1	1	MODULE COVER			71417020						
2	3	SCREW	HC M6X12		V3815407						
3	1	PROTECTIVE COVER			71417030						
4	1	SCREW			71257660						
5	1	TURBINE	H M6 X 15		71417080						
6	8	SCREW	CHC M8 X 30 Q8.8		V3811517						
7	13	WASHER	W8		V3600524						
8	2	RADIAL SHAFT SEAL	30/52X7	FKM	71417570						
9	1	END PLATE WITHOUT GB			971423900						
9	1	END PLATE WITH GB			971423930	Incl.12, 13, 14					
10	1	SCREW	HC M6X10 Q8.8		V3821415						
11	1	SCREW	M6		971424710						
12	1	GAS BALLAST VALVE			971431250	Incl. 11, 12a, b, c, d, e					
12a	1	O-RING	4.42 X 2.62	FKM	971424460						
12b	2	O-RING	10.77 X 2.62	FKM	71237320						
12c	1	SPRING			71417990						
12d	1	WASHER	M8		V3600501						
12e	1	LOCKING RING	D18 type 7000		V0800012						
13	1	GAS BALLAST 1.5 m3/h			71417050	Incl. 10, 12b, 13a					
13	1	GAS BALLAST 4 m3/h			71418710	Incl. 10, 12b, 13a					
13a	1	MEMBRAN	D12 X 2 70SH	FKM	71417060						
14	1	RILSAN TUBE	D5.5/8 LG230		71419130						
15	1	ROTOR WITH RINGS			71418740	Incl. 15a					
15a	2	ROTOR RING	DN25/30X38.5		971427720						
16	1	VANE SET OF 3			71418750						
17	1	O-RING	9.12 X 3.53	FKM	71417260						
18	1	O-RING	126.59 X 3.53	FKM	71417240						
19	1	PUMP CYLINDER			71418730	Incl. 19a					
19a	2	CENTERING PIN	DN8 L32		71233890						
20	4	RUBBER MOUNT	DN50 H30		71024220						
21	1	COUPLING UNIT			71418770	Incl. 21a, b, c					
21a	1	TOOTHED RING	POLYAMIDE		71418780						
21b	1	PUMP COUPLING			71418980						
21c	1	MOTOR COUPLING			71418990						
21	1	USA COUPLING UNIT			71419740	USA Incl. 21a, b, c					
21a	1	TOOTHED RING	POLYAMIDE		71418780						
21b	1	PUMP COUPLING			71418980						
21c	1	USA MOTOR COUPLING			71419750	USA					
22	16	SCREW	CHC M8 X 20 Q8.8		V3811513						
22	4	USA SCREW	CHC 3/8" X 19		V3814715	USA					
23	4	HEXAGON FLANGE NUT	H M8		V1507500						
24	1	COUPLING HOUSING			71418790						
24	1	USA COUPLING HOUSING			971427760	USA					
25	1	MOTOR EUR	2.2 kW 50/60Hz 230/400V		71418800	Incl.25a, b, c, d, e					
25a	1	KEY	2.65 kW 60Hz 460V		*						
25b	1	FAN MOTOR			*						
25c	1	FAN COVER MOTOR			*						
25d	1	TERMINAL BOX			*						
25e	1	TERMINAL BOARD			*						
25	1	MOTOR USA	5 HP 60Hz 230/460V		971423660	Incl.25a, b, c, d					
25a	1	KEY	5 HP 50Hz 400V		*						
25b	1	FAN MOTOR			*						
25c	1	FAN COVER MOTOR	CHC M10 X 80 Q8.8		*						
25d	1	TERMINAL BOX			*						
25e	1	TERMINAL BOARD			*						
25	1	MOTOR JAPAN	3.7 kW 50/60Hz 200V		971423670	Incl.25a, b, c, d, e					
25a	1	KEY			*						
25b	1	FAN MOTOR			*						
25c	1	FAN COVER MOTOR			*						
25d	1	TERMINAL BOX			*						
25e	1	TERMINAL BOARD			*						

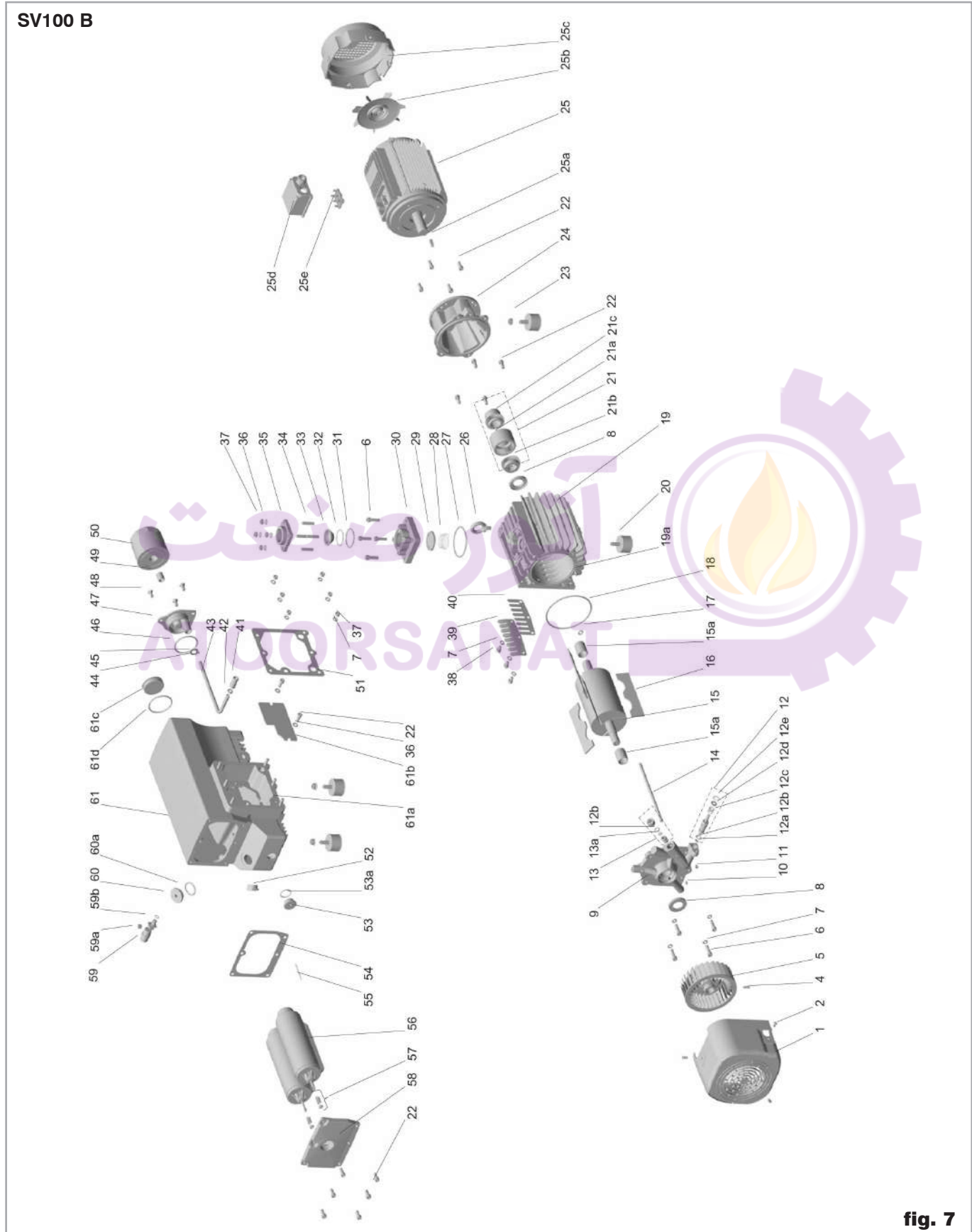

fig. 7

Pos.	Qty	Specification	Dimensions (mm)	Material	Ref, No,	Notes	714 20 410	714 20 420	714 20 80	9 714 23 430	9 714 23 440
25	1	MOTOR TAIWAN / BRASIL	2.2 kW 50/60Hz 230/400V		971423680	Incl.25a, b, c, d, e					
25a	1	KEY	2.7 kW 60Hz 230/400V		*						
25b	1	FAN MOTOR			*						
25c	1	FAN COVER MOTOR			*						
25d	1	TERMINAL BOX			*						
25e	1	TERMINAL BOARD			*						
26	1	LIFTING LUG	M8		71039700						
27	1	O-RING	82.14X3.53	FKM	71421340		●				
28	1	SPRING			71212400						
29	1	INTAKE VALVE		FKM	71015460		●				
30	1	INTAKE FLANGE			71416640						
31	1	O-RING	50X3	FKM	71217660		●				
32	1	O-RING	42X2	FKM	71237130		●				
33	1	FILTER	DN45		71407290						
34	4	LOCKING SCREW	M8-25/15J=12 Q6.8		V2100425						
35	1	INTAKE FLANGE	G1 1/4		71416650						
35	1	INTAKE FLANGE	NPT 1 1/4		71417390	USA					
36	6	WASHER	Z8		V3600513						
37	8	NUT	H M8 Q6		V1500501						
38	3	SCREW			V3811507						
39	1	VALVE STOP			71418840		●	●	●		
40	1	VALVE			71418830		●	●	●		
41	1	PIPE			71418930						
42	1	GASKET	DN10 X 15.5 X 4		71418910		●				
43	1	OIL RECOVERY PIPE			71418880						
44	1	RING			971424570		●				
45	1	O-RING	9.12 X 3.53	FKM	71417260		●				
46	1	O-RING	63.09 X 3.53	FKM	71417330		●				
47	1	OIL FILTER HOLDER			71418960	Incl. 45					
48	4	SCREW	Fhc M8X20		V3817407						
49	1	NIPPLE	3/4 16 UNF		71417150						
50	1	OIL FILTER			71213150			●			
51	1	FLAT GASKET			71418940		●				
52	1	OIL LEVEL GLASS	G3/4		71219480			●			
53	1	PLUG + O-RING	G3/4		71256380	Incl. 53a					
53a	1	O-RING	27 X 2.5	FKM	71217580		●			●	
54	1	FLAT GASKET		FKM	71418890		●			●	
55	1	CENTERING PIN	DN2.5		971427110						
56	2	EXHAUST FILTER			71417300			●		●	
57	2	SPRING UNIT			71420370			●		●	
58	1	EXHAUST FLANGE	G1 1/4		71418900						
58	1	EXHAUST FLANGE	NPT 1 1/4		71421780	USA					
59	1	FLOAT COMPL.			71417210	Incl. 59a, b					
59a	1	OIL RETURN VALVE SEAL			71212500		●				
59b	1	O-RING	8X2	FKM	71217650		●				
60	1	PLUG + O-RING	G1		71073040	Incl. 60a					
60a	1	O-RING	33 X 3.5	FKM	71217410		●			●	
61	1	OIL CASING WITH OIL FILTER			71420110	Incl. 61a, b, c, d					
61	1	OIL CASING WITHOUT OIL FILTER			971424390	Incl. 61a, b, c, d					
61a	6	LOCKING SCREW M8X25	M8 25-16/J=16		V2113426						
61b	1	GRID			71418950						
61c	2	PLUG + GASKET	G2		71212650	Incl. 61d					
61d	1	O-RING	56 X 2.5	FKM	71217980		●				
		SET OF SEALS		FKM	971427670						▲
		REPAIR KIT			971427680						▲
		VACUUM GENERATOR WITHOUT GB			971427740						▲
		VACUUM GENERATOR WITH GB			971427750						▲
		SERVICE KIT			971427690						▲

\*For every order, please indicate the brand and the serial number of motor and of the pump.

## EC Conformance Declaration



We, the Oerlikon Leybold Vacuum France, declare herewith that the products listed below, in the embodiment which we have placed on the market, comply with the applicable EC guidelines.

This declaration becomes invalid if modifications are made to the product without prior consultation with use. Maintaining the EMC guideline assumes an EMC compliant installation of the component within the plant or machine.

**Product type:** SOGEVAC

**Model designation:** SV16, SV25, SV40, SV65, SV10B, SV16B, SV16BI, SV28BI, SV40BI, SV25B, SV40B, SV65B, SV100B, SV100, SV200, SV300, SV500 SV630, SV750, SV1200, SV630B, SV750B  
and their variants, excepted the pumps delivered without motor and the pumps delivered with EEx... motors

**The products comply to the following guidelines :**

- EC Directive on machines (98/37/EC)
- EC Low-Voltage Equipment Guidelines (73/23/EMG)+(98/68/EC)
- EC Directive on Electromagnetic Compatibility (89/336/EEC)

**Related, harmonized standards:**

- EN 1012, 1996  
Compressors and vacuum pumps, safety requirements  
Part 2: Vacuum pumps
- EN 60204-1, 1997  
Safety of machinery - Electrical equipment of machines  
Part 1: General requirements

**Limits of use:**

- The pump and its accessories are not designed for pumping aggressive, flammable, explosive gases or vapors or substances, phrophoric gases or oxidizing agents.
- The pump and its accessories are not designed for working in aggressive, flammable, or explosive ambiance.
- For pumping oxygen in concentrations greater than atmospheric concentration (>20%) or other highly reactive gases, a special pump must be used. This pump must be modified and an inert oil (such as PFPE) must be used.

Contact Oerlikon Leybold Vacuum France for important safety precautions relative to these applications.

**Other safety precautions and restrictions:**

Refer to the manual delivered with the pumps. In any case, take adequate safety precautions.

Valence, January 12<sup>th</sup> 2007

Joseph Schott  
Plant Manager

Valence, January 12<sup>th</sup> 2007

Jean-Luc Abraham  
Vane pumps R&D Manager

**Oerlikon Leybold Vacuum France**  
640, rue Aristide Berges – BP107  
F-26501 BOURG-LES-VALENCE cédex  
Tel.: +33-(0)4.75.82.33.00  
Fax: +33-(0)4.75.82.92.69

[www.oerlikon.com](http://www.oerlikon.com)

### Declaration of Contamination of Compressors, Vacuum Pumps and Components

The repair and / or servicing of compressors, vacuum pumps and components will be carried out only if a correctly completed declaration has been submitted. **Non-completion will result in delay.** The manufacturer can refuse to accept any equipment without a declaration.

**A separate declaration has to be completed for each single component.**

This declaration may be completed and signed only by authorised and qualified staff.

Customer/Dep./Institute: _____	<b>Reason for return</b> <input checked="" type="checkbox"/> applicable please mark
Address: _____	<input type="checkbox"/> Repair <input type="checkbox"/> chargeable <input type="checkbox"/> warranty
Person to contact: _____	<input type="checkbox"/> Exchange <input type="checkbox"/> chargeable <input type="checkbox"/> warranty
Phone: _____ Fax: _____	<input type="checkbox"/> exchange already arranged / received
End user: _____	<b>Return only:</b> <input type="checkbox"/> rent <input type="checkbox"/> loan <input type="checkbox"/> for credit
	<b>Calibration:</b> <input type="checkbox"/> DKD <input type="checkbox"/> Factory calibration
	<input type="checkbox"/> Quality test certificate DIN 55350-18-4.2.1

<b>A. Description of the Leybold product</b>	Failure description: _____
Material description: _____	Additional parts: _____
Catalog number: _____	Application Tool: _____
Serial number: _____	Application Process: _____
Type of oil (Forevacuum pumps): _____	

<b>B. Condition of the equipment</b>			
1. Has the equipment been used <sup>1)</sup>	No <sup>1)</sup> <input type="checkbox"/>	Yes <input type="checkbox"/>	<b>Contamination:</b> <input type="checkbox"/> toxic <input type="checkbox"/> corrosive <input type="checkbox"/> flammable <input type="checkbox"/> explosive <sup>2)</sup> <input type="checkbox"/> radioactive <sup>2)</sup> <input type="checkbox"/> microbiological <sup>2)</sup> <input type="checkbox"/> other harmful substances
2. Drained (Product/service fluid)	<input type="checkbox"/>	<input type="checkbox"/>	
3. All openings sealed airtight	<input type="checkbox"/>	<input type="checkbox"/>	
4. Purged	<input type="checkbox"/>	<input type="checkbox"/>	
If yes which cleaning agent: _____ and which method of cleaning: _____			
1) if answered with "No" go to <b>D.</b>			No <sup>1)</sup> <input type="checkbox"/> Yes <input type="checkbox"/>

<b>C. Description of processed substances (Please fill in absolutely)</b>	
1. What substances have come into contact with the equipment: Trade name and / or chemical term of service fluids and substances processed, properties of the substances; According to safety data sheet (e.g. toxic, inflammable, corrosive, radioactive)	
Tradename: _____	Chemical name: _____
a) _____	
b) _____	
c) _____	
d) _____	
2. Are these substances harmful?	No <input type="checkbox"/> Yes <input type="checkbox"/>
3. Dangerous decomposition products when heated?	No <input type="checkbox"/> Yes <input type="checkbox"/>
If yes, which? _____	

**<sup>2)</sup> Components contaminated by microbiological, explosive or radioactive products/substances will not be accepted without written evidence of decontamination.**

#### D. Legally binding declaration

I / we hereby declare that the information supplied on this form is accurate and sufficient to judge any contamination level.

Name of authorised person (block letters): \_\_\_\_\_

Date \_\_\_\_\_ Signatur of authorised person \_\_\_\_\_

firm stamp

# Notes

آتور صنعت  
ATOORSANAT





آتور صنعت  
ATOORSANAT



# Sales and Service

## Germany

**Oerlikon**  
**Leybold Vacuum GmbH**  
Bonner Strasse 498  
D-50968 Cologne  
Phone: +49-(0)221-347 1234  
Fax: +49-(0)221-347 1245  
sales.vacuum@oerlikon.com

**Oerlikon**  
**Leybold Vacuum GmbH**  
**Sales Area North/East**  
Branch Office Berlin  
Buschkrugallee 33  
1. Obergeschoss  
D-12359 Berlin  
Phone: +49-(0)30-435 609 0  
Fax: +49-(0)30-435 609 10  
sales.vacuum.bn@oerlikon.com

**Oerlikon**  
**Leybold Vacuum GmbH**  
**Sales Area South/Southwest**  
Branch Office Munich  
Sendlinger Strasse 7  
D-80331 Munich  
Phone: +49-(0)89-357 33 9-10  
Fax: +49-(0)89-357 33 9-33  
sales.vacuum.mn@oerlikon.com  
service.vacuum.mn@oerlikon.com

**Oerlikon**  
**Leybold Vacuum GmbH**  
**Sales Area West & Benelux**  
Bonner Strasse 498  
D-50968 Cologne  
Phone: +49-(0)221-347 1270  
Fax: +49-(0)221-347 1291  
sales.vacuum.kn@oerlikon.com

**Oerlikon**  
**Leybold Vacuum GmbH**  
**Service Competence Center**  
Emil-Hoffmann-Strasse 43  
D-50996 Cologne-Suerth  
Phone: +49-(0)221-347 1439  
Fax: +49-(0)221-347 1945  
service.vacuum.kn@oerlikon.com

**Oerlikon**  
**Leybold Vacuum GmbH**  
**Mobil Customer Service**  
Emil-Hoffmann-Strasse 43  
D-50996 Cologne-Suerth  
Phone: +49-(0)221-347 1765  
Fax: +49-(0)221-347 1944  
service.vacuum.kn@oerlikon.com

**Oerlikon**  
**Leybold Vacuum GmbH,**  
**Dresden**  
Zur Wetterwarte 50, Haus 304  
D-01109 Dresden  
Service:  
Phone: +49-(0)351-88 55 00  
Fax: +49-(0)351-88 55 041  
info.vacuum.dr@oerlikon.com

**Oerlikon**  
**Leybold Vacuum USA Inc.**  
5700 Mellon Road  
Export, PA 15632  
Phone: +1-724-327-5700  
Fax: +1-724-325-3577  
info.vacuum.ex@oerlikon.com

## Europe

Belgium  
**Oerlikon**  
**Leybold Vacuum Nederland B.V.**  
**Belgisch bijkantoor**  
Leuvensesteenweg 542-9A  
B-1930 Zaventem  
Sales:  
Phone: +32-2-711 00 83  
Fax: +32-2-720 83 38  
sales.vacuum.zv@oerlikon.com  
Service:  
Phone: +32-2-711 00 82  
Fax: +32-2-720 83 38  
service.vacuum.zv@oerlikon.com

France  
**Oerlikon**  
**Leybold Vacuum France S.A.**  
7, Avenue du Québec  
Z.A. Courtaboeuf 1 - B.P. 42  
F-91942 Courtaboeuf Cedex  
Sales and Service:  
Phone: +33-1-69 82 48 00  
Fax: +33-1-69 07 57 38  
sales.vacuum.or@oerlikon.com

**Oerlikon**  
**Leybold Vacuum France S.A.**  
**Valence Factory**  
640, Rue A. Bergès - B.P. 107  
F-26501 Bourg-lès-Valence Cedex  
Phone: +33-4-75 82 33 00  
Fax: +33-4-75 82 92 69  
info.vacuum.vc@oerlikon.com

Great Britain  
**Oerlikon**  
**Leybold Vacuum UK LTD.**  
Unit 2  
Silverglade Business Park  
Leatherhead Road  
UK-Chessington, Surrey KT9 2QL  
Sales:  
Phone: +44-13-7273 7300  
Fax: +44-13-7273 7301  
sales.vacuum.ln@oerlikon.com  
Service:  
Phone: +44-20-8971 7030  
Fax: +44-20-8971 7003  
service.vacuum.ln@oerlikon.com

Italy  
**Oerlikon**  
**Leybold Vacuum Italia S.p.A.**  
8, Via Trasimeno  
I-20128 Milano  
Sales:  
Phone: +39-02-27 22 31  
Fax: +39-02-27 20 96 41  
sales.vacuum.mi@oerlikon.com  
Service:  
Phone: +39-02-27 22 31  
Fax: +39-02-27 22 32 17  
service.vacuum.mi@oerlikon.com

**Oerlikon**  
**Leybold Vacuum Italia S.p.A.**  
Field Service Base  
Z.I. Le Capanne  
I-05021 Acquasparta (TR)  
Phone: +39-0744-93 03 93  
Fax: +39-0744-94 42 87  
service.vacuum.mi@oerlikon.com

Netherlands  
**Oerlikon**  
**Leybold Vacuum Nederland B.V.**  
Computerweg 7  
NL-3542 DP Utrecht  
Sales and Service:  
Phone: +31-346-58 39 90  
Fax: +31-346-58 39 90  
sales.vacuum.ut@oerlikon.com  
service.vacuum.ut@oerlikon.com

Spain  
**Oerlikon**  
**Leybold Vacuum Spain, S.A.**  
C/ Huelva, 7  
E-08940 Cornellà de Llobregat  
(Barcelona)  
Sales:  
Phone: +34-93-666 46 16  
Fax: +34-93-666 43 70  
sales.vacuum.ba@oerlikon.com  
Service:  
Phone: +34-93-666 49 51  
Fax: +34-93-685 40 10

Sweden  
**Oerlikon**  
**Leybold Vacuum Scandinavia AB**  
Box 9084  
SE-40092 Göteborg  
Sales and Service:  
Phone: +46-31-68 84 70  
Fax: +46-31-68 39 39  
info.vacuum.gt@oerlikon.com  
Visiting/delivery address:  
Datavägen 57B  
SE-43632 Askim

Switzerland  
**Oerlikon**  
**Leybold Vacuum Schweiz AG**  
Leutschenbachstrasse 55  
CH-8050 Zürich  
Sales:  
Phone: +41-044-308 40 50  
Fax: +41-044-302 43 73  
sales.vacuum.zh@oerlikon.com  
Service:  
Phone: +41-044-308 40 62  
Fax: +41-044-308 40 60

## America

USA  
**Oerlikon**  
**Leybold Vacuum USA Inc.**  
5700 Mellon Road  
Export, PA 15632  
Phone: +1-724-327-5700  
Fax: +1-724-325-3577  
info.vacuum.ex@oerlikon.com  
Sales:  
Eastern & Central time zones  
Phone: +1-724-327-5700  
Fax: +1-724-733-1217  
Pacific, Mountain, Alaskan &  
Hawaiian time zones  
Phone: +1-480-752-9191  
Fax: +1-480-752-9494  
Service:  
Phone: +1-724-327-5700  
Fax: +1-724-733-3799

**Oerlikon**  
**Leybold Vacuum GmbH**  
Bonner Strasse 498  
D-50968 Cologne  
Phone: +49-(0)221-347 0  
Fax: +49-(0)221-347 1250  
info.vacuum@oerlikon.com

## Asia

P.R. China  
**Oerlikon**  
**Leybold Vacuum (Tianjin)**  
**International Trade Co., Ltd.**  
Beichen Economic  
Development Area (BEDA),  
Shanghai Road  
Tianjin 300400  
China  
Sales and Service:  
Phone: +86-22-2697 0808  
Fax: +86-22-2697 4061  
Fax: +86-22-2697 2017  
sales.vacuum.tj@oerlikon.com

**Oerlikon**  
**Leybold Vacuum**  
**(Tianjin) Co., Ltd.**  
Beichen Economic  
Development Area (BEDA),  
Shanghai Road  
Tianjin 300400  
China  
Sales and Service:  
Phone: +86-22-2697 0808  
Fax: +86-22-2697 4061  
Fax: +86-22-2697 2017  
info.vacuum.tj@oerlikon.com

**Oerlikon**  
**Leybold Vacuum (Tianjin)**  
**International Trade Co., Ltd.**  
Shanghai Branch:  
Add: No. 33  
76 Futedong San Rd.  
Waigaoqiao FTZ  
Shanghai 200131  
China  
Sales and Service:  
Phone: +86-21-5064-4666  
Fax: +86-21-5064-4668  
info.vacuum.sh@oerlikon.com

**Oerlikon**  
**Leybold Vacuum (Tianjin)**  
**International Trade Co., Ltd.**  
Guangzhou Office and  
Service Center  
1st F, Main Building,  
Science City Plaza,  
No.111 Science Revenue,  
Guangzhou Science City  
(GZSC) 510663, Guangzhou,  
China  
Sales:  
Phone: +86-20-22323980  
Fax: +86-20-22323990  
info.vacuum.gz@oerlikon.com

**Oerlikon**  
**Leybold Vacuum (Tianjin)**  
**International Trade Co., Ltd.**  
Beijing Branch:  
1-908, Beijing Landmark Towers  
8 North Dongsanhuan Road  
Chaoyang District  
Beijing 100004  
China  
Sales:  
Phone: +86-10-6590-7622  
Fax: +86-10-6590-7607

India  
**Oerlikon**  
**Leybold Vacuum India Pvt Ltd.**  
EL-22, J Block  
MIDC Bhosari  
Pune 411026  
India  
Sales:  
Phone: +91-20-3061 60000  
Fax: +91-20-2712 1571  
sales.vacuum.pu@oerlikon.com

Japan  
**Oerlikon**  
**Leybold Vacuum**  
**Japan Co., Ltd.**  
Head Office  
Tobu A.K. Bldg. 4th Floor  
23-3, Shin-Yokohama  
3-chome  
Kohoku-ku, Yokohama-shi  
Kanagawa-ken 222-0033  
Sales:  
Phone: +81-45-471-3330  
Fax: +81-45-471-3323

**Oerlikon**  
**Leybold Vacuum**  
**Japan Co., Ltd.**  
Osaka Sales Office  
5-13, Kawagishi-cho  
Suita-chi  
Osaka-fu  
Phone: +81-6-4860-2212  
Fax: +81-45-471-3323

**Oerlikon**  
**Leybold Vacuum**  
**Japan Co., Ltd.**  
Tsukuba Technical S.C.  
Tsukuba Minami Daiichi  
Kogyo Danchi  
21, Kasumi-no-Sato,  
Ami-machi, Inashiki-gun  
Ibaraki-ken, 300-0315  
Service:  
Phone: +81-29-889-2841  
Fax: +81-29-889-2838

Korea  
**Oerlikon**  
**Leybold Vacuum Korea Ltd.**  
#761-4, Yulkeum-ri  
SungHwan-eup, Cheonan-City  
Choongchung-Namdo  
330-807 Korea  
Sales:  
Phone: +82-41-580-4420  
Fax: +82-41-588-3737  
Service:  
Phone: +82-41-580-4415  
Fax: +82-41-588-3737

Singapore  
**Oerlikon**  
**Leybold Vacuum**  
**Singapore Pte Ltd.**  
1 Science Park Road  
Singapore Science Park 2  
#02-12 Capricorn Building  
Singapore 117528  
Sales and Service:  
Phone: +65-6303 7000  
Fax: +65-67730 039  
info.vacuum.sg@oerlikon.com

Taiwan  
**Oerlikon**  
**Leybold Vacuum Taiwan Ltd.**  
No 416-1, Sec. 3  
Chung-Hsin Rd., Chu-Tung  
Hsin-Chu, Taiwan, R.O.C.  
Sales and Service:  
Phone: +886-3-500 1688  
Fax: +886-3-583 3999  
sales.vacuum.hc@oerlikon.com

**oerlikon**  
leybold vacuum

www.oerlikon.com