



ROTOFLUID

FTSS Series



ADVANCED TECHNOLOGY FOR PUMPING VISCOUS LIQUID

ADVANCED TECHNOLOGY FOR PUMPING VISCOUS LIQUID

Fluid Tech Systems Offers "ROTOFLUID" brand gear pump model "FTSS" which is self priming bi-directional, positive displacement rotary pump in all stainless steel (SS-316) investment ment casting construction with nitrided gear/shaft & dry - teflon coated DU bush bearing requiring no lubrication. These pumps in three piece construction are easily cleanable and maintainable. The back cover can simply be removed by four dom nut or the right angle mounting brackets facilitate foot mounting of the pump on base plate with electric motor of appropriate ratings.

MATERIAL OF CONSTRUCTION

- Pump Body : CF8M - S.S.316
- R.H.&L.H. Gear : AISI - S.S.316
- Dom Nut : AISI - S.S.316
- Front Cover : CF8M- S.S.316
- Rotor/Stator Shaft : AISI - S.S.316
- Sealing : "Z" Pack teflon
- Back Cover : CF8M - S.S.316
- Bush Bearings : Teflon coated "DU"
- Packing : Teflon Sheet
- Giand Cover : CF8M- S.S.316
- Mounting Bracket : C.I.Gr- IS 210
- Key for Coupling : AISI S.S.316

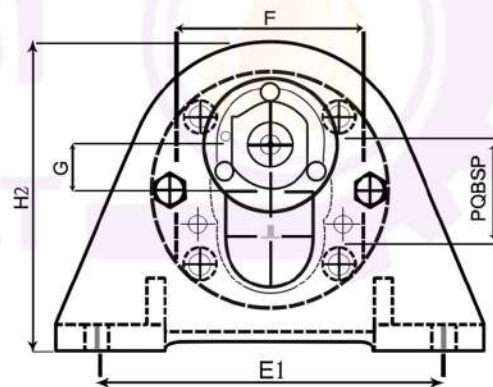
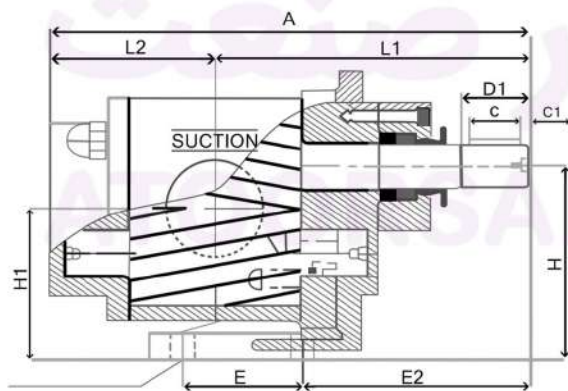

MODEL & POWER CHART

PUMP MODEL FTSS	SUCTION & DELIVERY	CAPACITY at 1440 RPM			POWER REQ			Unit H.P Per Kg-Press	PUMP DIMENSION													WT. OF PUMP IN KG	
		LPM	US GPM	M3/hr	NO LOAD VISCIOUS H.P. at				OVER ALL						MOUNTING & SHAFT								
					200 CST	500 CST	750 CST		A	F G	H2	L1	L2	E	E1	E2	H	H1	D D1	C C1	P Q		B1
025	1/4"x1/4"	8.3	2.2	0.5	0.20	0.25	0.35	0.02	129	54 12.5	101	94	35	40	120	82	63	50.5	11.5 8	17 3	4 13	25	2.00
040	3/8"x3/8"	16.6	4.4	1.0	0.35	0.40	0.55	0.04	134	61	112	98	36	50	120	88	71	57	11.5	17	4	25	3.00
050	1/2"x1/2"	25	6.6	1.5	0.40	0.50	0.70	0.06	146	14	112	103	41	50	120	88	71	57	8	3	13	25	3.50
075	3/4"x3/4"	33.3	8.8	2.0	0.45	0.55	0.90	0.09	160	72.5	128	123	46	55	140	92	90	73	14	25	5	35	4.50
100	1"x1"	50	13.2	3.0	0.50	0.60	1.0	0.13	177	17	128	115	52	55	140	92	90	73	10.5	3	16	35	5.00
125	1 1/4"x1 1/4"	100	26.4	6.0	0.65	0.85	1.25	0.28	210	90	149	143	66	50	155	111	100	79	18	30	6	38	7.00
150	1 1/2"x1 1/2"	125	33.0	7.5	0.75	0.95	1.50	0.35	225	21	149	151	73	50	155	111	100	79	12	3	20.5	38	10.50
200	2"x2"	150	39.6	9.0	0.90	1.15	1.75	0.45	251	103	167	162	85	70	190	131	112	87	24	30	8	40	20.50
200		200	52.8	12.0	1.00	1.25	2.15	0.60	281	25	167	179	97	70	190	131	112	87	14	5	27	40	24.00
250	2 1/2"x2 1/2"	250	66.0	15.0	1.20	1.40	2.35	0.65	299	122	197	206	93	85	200	161	132	102	28	40	8	50	35.00
250		300	79.25	18.0	1.40	1.65	2.50	0.77	319	30	197	218	101	85	200	161	132	102	16	5	32	50	40.00

SPECIAL NOTE

For calculating the power requirement at duty point, multiply the duty point pressure with unit horse power & add no load viscous power of appropriate viscosity, provide safety margin before fixing the rating of the prime mover. for higher viscosity further margin may be kept or the manufacturer may be consulted. All sizes of “**FTSS**” pumps are designed to run at 1440 RPM up to viscosity of 500 CST. For small pump sizes up to 1” same can be safety run at 1440 RPM even at higher viscosity up to 1000 CST with additional horse power. For sizes above 1” reduce the speed to 960 RPM for viscosity up too 1000 CST. For higher viscous liquids , consult the manufacturer to avoid cavitation & overloadin problem.

APPLICATION

This compact and efficient SS pump can be used for handling viscous food products like Ghee, Butter, Fruit pulp, vegetable, sauce, starch etc. They are also used in pharmaceutical industries for handling sugar solution, Glycerine, Glycol etc. In chemical industries corrosive viscous chemicals can be easily handled with this pump most effectively.