

# **ELK** **MOTOR**

**IE2 and IE3  
THREE PHASE ASYNCHRONOUS  
ELECTRIC MOTORS**

**PRODUCT CATALOGUE**

**ELK 0400-0616**





ATOORSANAT



ATOORSANAT

## PRODUCTION SITE AND PRODUCTION TECHNOLOGY

ELK Motor has been founded by major shareholders of Yılmaz Redüktör A.Ş. as the continuation of the product family. ELK motor manufactures electric motors from 71 up to and including 180 IEC frame size in a 40.000m<sup>2</sup> closed area built on a 100.000m<sup>2</sup> open area.

ELK motors are designed and manufactured completely in accordance with European standard with its whole product range. IE2 and IE3 efficiency classes are available in full product range currently.

**ELK**  
MOTOR

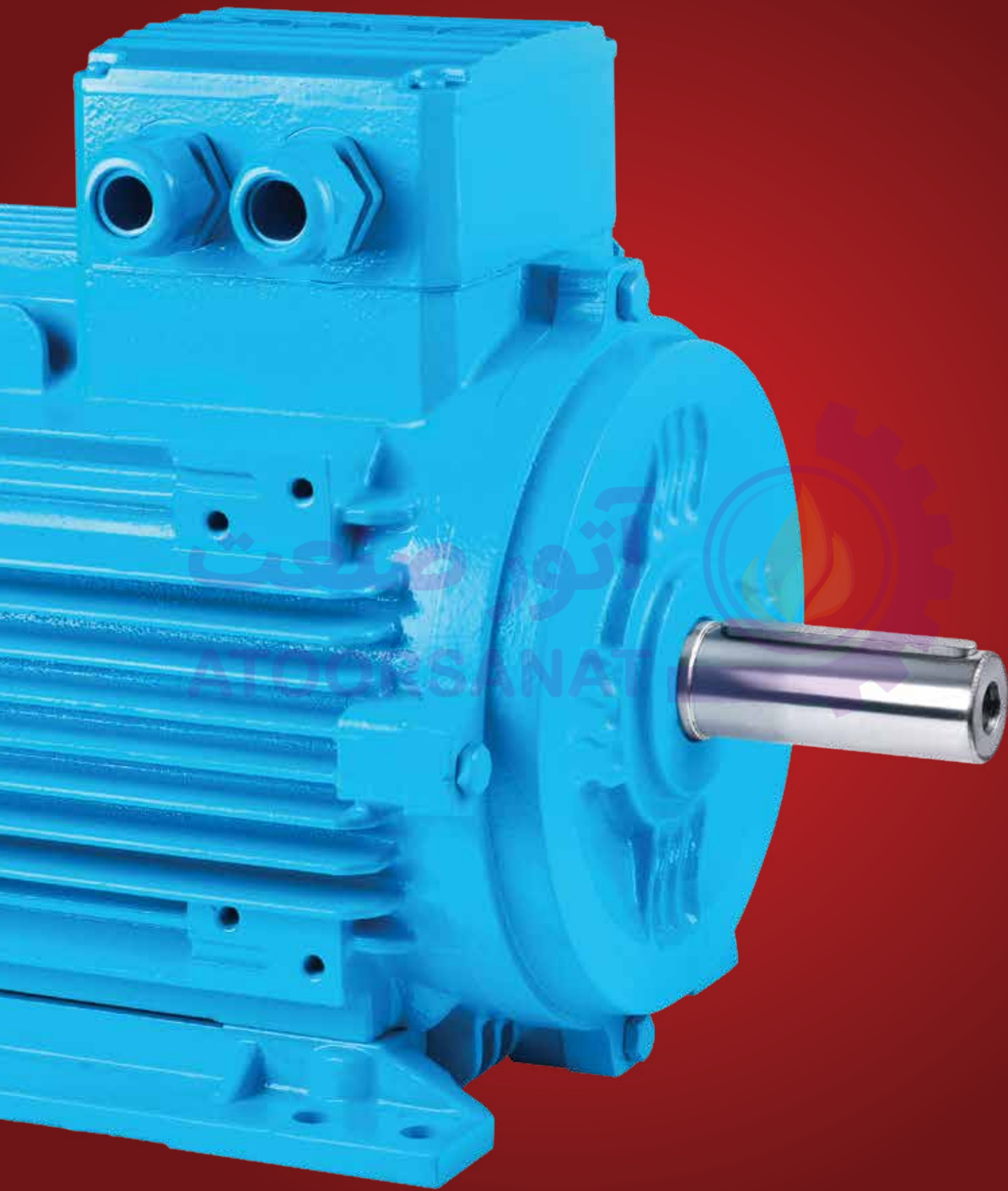

## IE2 and IE3 Motors

The main design and technology of ELK motor is completely suitable to the IE3 efficiency class. Since the outside dimensions of the IE3 and IE2 design are completely same the replacement of the IE2 motor with IE3 motors will be done easily.

In addition to the motors according to the European standards, ELK motor also manufactures special motors for its customers to decrease the cost and increase the productivity.

**ELK**  
MOTOR

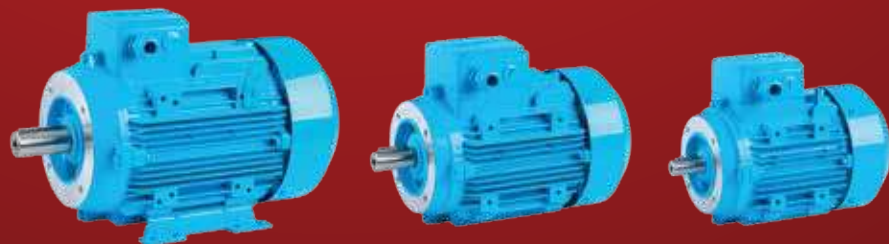



آتور صنعت  
ATOORSANAT

## ELK Motors;

From engineering to manufacturing processes ELK motors are completely manufactured in our factory located in Çerkezköy, 100km far away from Istanbul.

Motor shafts and end shields are manufactured by fully automatic CNC machines under a continuous quality control. The rotor and stator cores are manufactured in our fully automatic punching and interlocking lines.



# ATOORSANAT

After injecting the pure aluminum into the rotor cores in a fully automatic rotor injection line the rotor cores becomes ready for assembly. In automatic winding lines stator cores are wound and varnished either by automatic dipping method or VPI (Vacuum Pressure Impregnation) method according to the needs and usage area. So the products are always in the best levels of quality and performance.

After all of these operations, our motors which are assembled in accordance with product prescriptions, are being tested and controlled fully for the last time and shipped to the customers after packaging.



**ELK**  
MOTOR



## TECHNICAL INFORMATION

All of our standard products are designed, manufactured, and tested according to the IEC and EN standards given below:

IEC 60034-1	Rating and performance
IEC 60034-2-1	Methods for determining losses and efficiency
IEC 60034-5	Classification of degrees of protection
IEC 60034-6	Methods of cooling
IEC 60034-7	Symbols of construction and mounting arrangements
IEC 60034-8	Terminal markings and direction of rotation
IEC 60034-9	Noise limits
IEC 60034-11	Built-in thermal protection
IEC 60034-14	Vibration limits
IEC 60034-18-1	Functional evaluation of insulation system
IEC 60034-30	Efficiency classes (IE-code)
IEC 60038	Standard voltages
EN 50347	Dimensions and output for electrical machines

EN 55014-1	} Electromagnetic compatibility
EN 61000-3-2	
EN 61000-3-3	

According to IEC 60034-1, catalogue values are permitted to deviate from the real values as follows:



<b>Speed (n)</b>	$\Delta n = \pm 20\% (n_s - n_N), P_N > 1 \text{ kW}$ $\Delta n = \pm 30\% (n_s - n_N), P_N \leq 1 \text{ kW}$
<b>Efficiency %(<math>\eta</math>)</b>	$\Delta \eta = -15\% (100 - \eta_N), P_N \leq 150 \text{ kW}$ $\Delta \eta = -10\% (100 - \eta_N), P_N > 150 \text{ kW}$
<b>Power factor (cos <math>\phi</math>)</b>	$\text{Cos } \phi = -1/6 (1 - \text{Cos } \phi)$
<b>Locked rotor current (<math>I_{LN}</math>)</b>	$\Delta (I_{LN}) = +20\% (I_{LN})$
<b>Starting Torque (<math>M_L/M_N</math>)</b>	min. ( $M_L/M_N$ ) = -15% ( $M_L/M_N$ ) max. ( $M_L/M_N$ ) = +25% ( $M_L/M_N$ )
<b>Break down Torque (<math>M_K/M_N</math>)</b>	$(M_K/M_N) = -10\% (M_K/M_N)$
<b>Moment of Inertia (J) [kgm<sup>2</sup>]</b>	$\Delta J = \pm 10\% J$
<b>Sound Pressure Level (<math>L_{PA}</math>) [dB(A)]</b>	$L_{PA} = +3 \text{ dB (A)}$

## TECHNICAL INFORMATION

### MECHANICAL CONSTRUCTION

71-132 frame size ELK Motors provides flexibility for different mounting types through their detachable feet which can be mounted on three sides. This feature allows terminal box assembly on the desired side. Terminal box is on the top for standard motors. 160 and 180 frame size motors have fixed feet construction.

#### FRAME SIZE 71-132

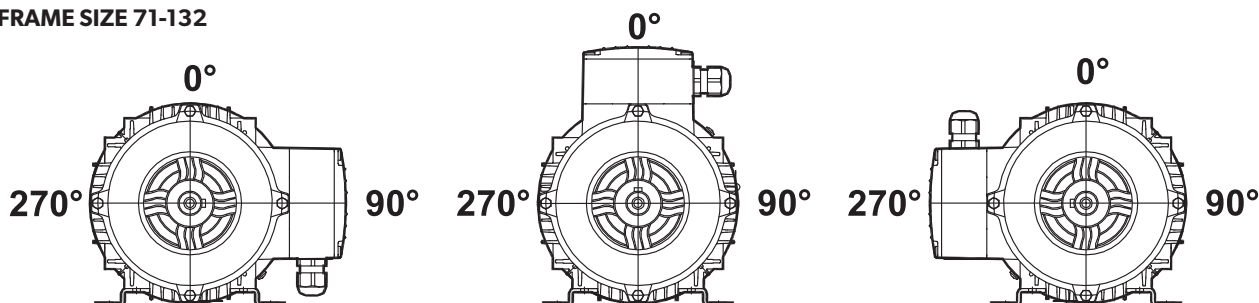

#### FRAME SIZE 160-180

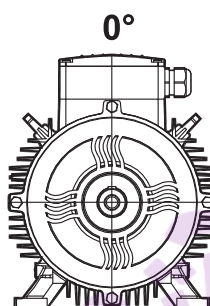

Additionally the housing and end shields are designed symmetrically for all of the frame sizes, so that the drive and non-drive side end shields can be replaced and the direction of the rotor shaft group can be changed. By making this end shields and rotor shaft group modifications the user can have a motor with terminal box is at the non-drive side keeping the distance C according to the standard.

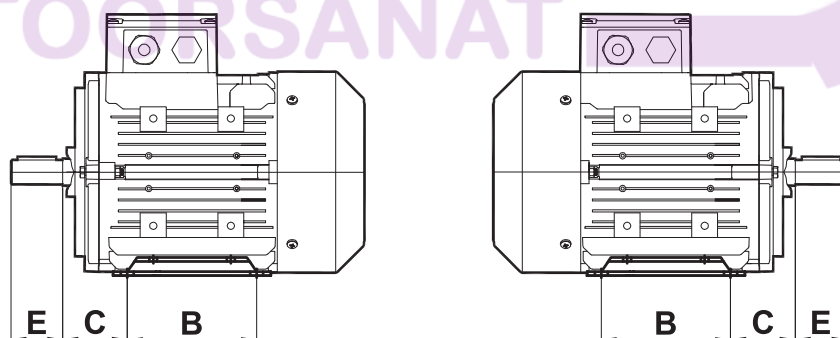

The row materials that we use in our motor depending on the frame size are listed below.

Frame Size	Housing	End Shields	Terminal Box and Cover	Feet	Fan Cover	Fan
71	Aluminum	Aluminum	Aluminum	Steel	Steel	Plastic
80	Aluminum	Aluminum	Aluminum	Steel	Steel	Plastic
90	Aluminum	Aluminum	Aluminum	Steel	Steel	Plastic
100	Aluminum	Aluminum	Aluminum	Steel	Steel	Plastic
112	Aluminum	Aluminum	Aluminum	Steel	Steel	Plastic
132	Aluminum	Aluminum	Aluminum	Steel	Steel	Plastic
160	Cast Iron	Cast Iron	Cast Iron	Cast Iron	Steel	Plastic
180	Cast Iron	Cast Iron	Cast Iron	Cast Iron	Steel	Plastic

## TECHNICAL INFORMATION

### ELECTRICAL CONSTRUCTION

Our standard motors have insulation Class F while the temperature rise is Class B. This means the motors will have a longer service life and work under hard conditions.

Upon the customer's request, Class H insulation motors are manufactured.

### ELECTRICAL CONNECTIONS

Frame Size	71 - 80 - 90	100 - 112 - 132	160 - 180
Cable Glands	M20 + M16	M25 + M25	M32 + M32

The motors shall be connected in star or delta according to rated voltage given in their nameplate and the network voltage that they will be connected. For phase to phase 400 V supply the motors with 230/400V nameplate values shall be connected in star and the motors with 400/690V nameplate values shall be connected in delta.

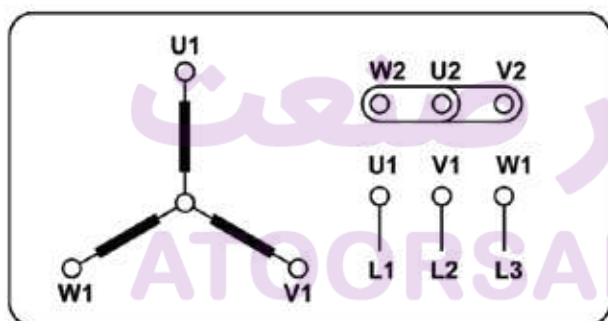

Y Star Connection

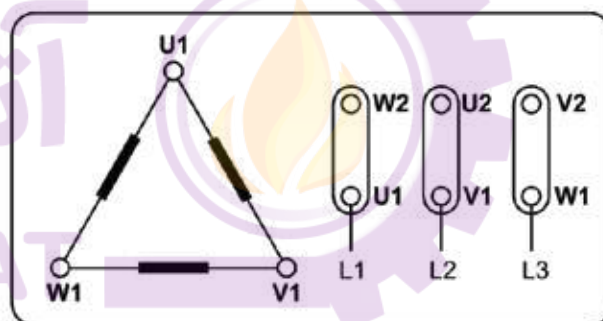

Δ Delta Connection

### RUNNING THE MOTORS AT 60Hz NETWORK

Our standard motors that have been manufactured for 50 Hz power supply can be used at 60 Hz network. The ratios given below indicate changes in the given rated values.

50 Hz Rated Voltage	60 Hz Supply Voltage	Rated Speed	Rated Power	Rated Torque	Rated Current	Starting Torque	Break Down Torque	Starting Current
230V	220V	1.193	1	0.84	0.97	0.77	0.8	0.8
400V	380V	1.193	1	0.84	0.97	0.77	0.8	0.8
400V	440V	1.20	1.16	0.97	0.98	0.87	0.9	0.9

## TECHNICAL INFORMATION

### SPEED CONTROL AND DRIVERS

Standard ELK motors are suitable for electronic speed control operations. The frequency range that the motor can be driven with their fan is given below with blue line. If the motor will be driven in a wider range then an external fan is necessary. By using an external fan the motors can be driven in the range defined by red line.

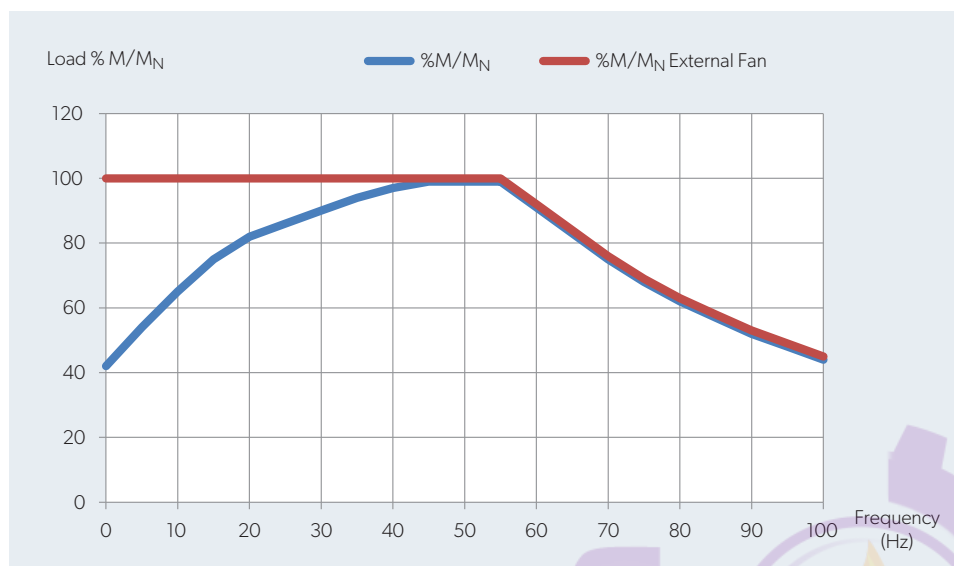

### ENVIRONMENTAL CONDITIONS

Motors are designed to operate at ambient temperature up to 40°C according to IEC 60034-1. Rated output will change at the % ratings given below for different ambient temperatures

Ambient Temperature	<30 °C	35 °C	40 °C	45 °C	50 °C	55 °C	60 °C
% Power Ratio	105	102	100	97	93	87	82

## TECHNICAL INFORMATION

### BEARINGS

Standard motors are equipped with deep groove ball bearings with ZZ shields as listed below according to the frame size. NU NJ type bearing are optional.

Frame Size	Drive Side End Shield	Non Drive Side End Shield
71	6202 ZZ	6202 ZZ
80	6204 ZZ	6204 ZZ
90	6205 ZZ	6205 ZZ
100	6206 ZZ	6206 ZZ
112	6206 ZZ	6206 ZZ
132	6208 ZZ	6208 ZZ
160	6309 ZZ	6209 ZZ
180	6310 ZZ	6210 ZZ

آتور صنعت  
ATOORSANAT

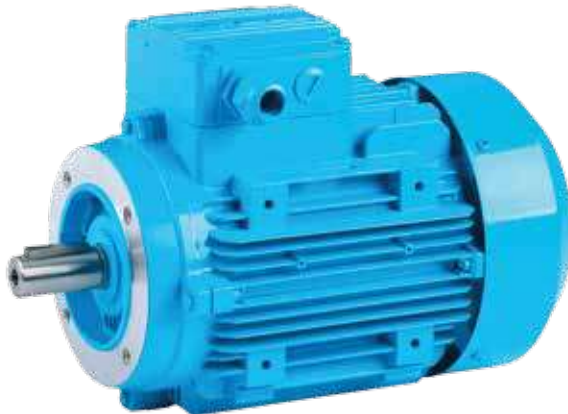

## TECHNICAL INFORMATION

### PRODUCT TYPE CODES

2 EL 132 M 4 C FC 00 000

**Additional Motor Features**  
000.....999 000 : Standard Motor

Electrical Specifications:  
AA..ZZ Voltage, frequency etc.

Construction Types/Flange Types  
PD : Feet mounted B3 type construction  
FA : With B5 flange  
FC : With B14a flange  
FS : With special flange  
PA : Feet mounted B5 type construction  
PC : Feet mounted B14a type construction  
PS : Feet mounted with special flange  
Y0..Y9: With flange for gearbox connection  
PX : Feet mounted without drive side end shield  
XX : Without feet and drive side end shield  
Z0-Z9: With feet and special gearbox flange

Core Length: A, B, C, D

Number of Poles  
2: 2 poles 3000 rpm  
4: 4 poles 1500 rpm  
6: 6 poles 1000 rpm  
D: dahlander 4/2 poles constant torque 1500/3000 rpm  
E : dahlander 4/2 poles square-law torque 1500/3000 rpm  
F : dahlander 8/4 pole constant torque 750/1500 rpm  
G: dahlander 8/4 poles square-law torque 750/1500 rpm  
S : separate windings 6/4 poles 1000/1500 rpm  
T : separate windings 12/4 poles 500/1500 rpm  
U : separate windings 12/2 poles 500/3000 rpm  
Z: 12 poles 500 rpm

Housing Length  
S: Short  
M: Medium  
L: Long

Frame Sizes: 71, 80, 90, 100, 112, 132, 160, 180  
The height of the shaft axis from feet base of motor (mm)

Basic Motor Types  
EL : Aluminum housing standard motors  
EG : Cast iron housing standard motors  
EC : Aluminum housing compact motors  
ED : Cast iron housing compact motors

Motor Efficiency Classes:  
1: IE1  
2: IE2  
3: IE3

## TECHNICAL INFORMATION

### PRODUCT TYPE CODES

00

#### Electrical Specifications

AA..ZZ Voltage, frequency etc.

#### 2nd digit: Additional Electrical Features

0: Standard motor, basic version  
A: Motors with thermistor  
B: Motors with heater  
C: Motors with thermal switch  
K: Motors with thermistor and heater

#### 1st digit : Voltage and Frequency

A: 230/400V 50Hz  
B: 400/690V 50Hz  
C: 240/415V 50Hz  
D: 415/720V 50Hz  
E: 220/380V 60Hz Standard power  
F: 380/660V 60Hz Standard power  
G : 220V 60Hz  
H : 290/500V 50Hz  
I: 220/380V 60Hz 16% increased rated output power  
J: 380/660V 60Hz 16% increased rated output power

آتور صنعت  
ATOORSANAT

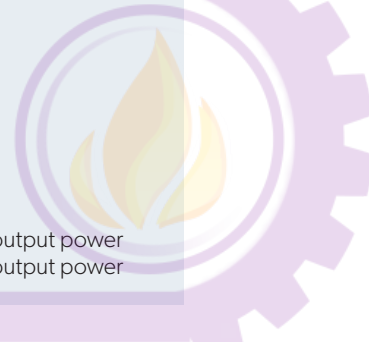

## PERFORMANCE AND DIMENSIONS

ELECTRICAL CHARACTERISTICS 400V 50Hz 3000 rpm

IE2

Voltage (V)	Type	Rated Values								Starting Values		Breakdown Torque	Moment of Inertia	B3 Motor Weight	Sound Pressure Level
		Power	Speed	Current	Torque	Power Factor	Efficiency % $\eta$			Current	Torque				
		kW	rpm	A	Nm	Cos $\phi$	4/4	3/4	1/2	$I_A/I_N$	$M_A/M_N$				
230/400	2EL071M2A	0,37	2805	0,90	1,26	0,80	74,2	74,5	72,5	5,0	2,5	2,8	0,00067	5,5	54
	2EL071M2B	0,55	2800	1,25	1,87	0,84	75,8	77,0	76,0	5,0	2,4	2,7	0,00086	6,3	54
	2EL080M2A	0,75	2850	1,67	2,51	0,83	78,0	79,0	77,5	5,7	2,5	3,0	0,00120	8,7	56
	2EL080M2B	1,10	2850	2,36	3,69	0,84	80,1	81,3	80,7	5,8	2,7	3,1	0,00140	9,7	56
	2EL090S2A	1,50	2880	3,19	4,98	0,83	81,8	82,6	82,0	6,0	2,4	3,1	0,00200	14,1	60
	2EL090L2B	2,20	2860	4,48	7,35	0,85	83,2	85,0	85,0	6,0	2,6	3,1	0,00220	15,5	60
	2EL100L2B	3,00	2900	5,80	9,88	0,88	84,8	85,2	84,7	7,0	2,6	3,4	0,00460	20,8	63
400/690	2EL112M2A	4,00	2910	7,50	13,13	0,89	86,5	87,1	86,8	7,0	2,4	3,6	0,00850	25,7	66
	2EL132S2A	5,50	2930	10,20	17,93	0,89	87,4	87,8	87,0	7,5	2,4	3,7	0,01900	41,0	68
	2EL132S2B	7,50	2925	13,60	24,50	0,90	88,5	88,8	88,6	7,6	2,6	3,7	0,02200	45,2	68
	2EG160M2A	11,00	2940	19,70	35,73	0,90	89,4	89,6	88,2	7,4	2,4	3,5	0,04400	106,6	70
	2EG160M2B	15,00	2935	27,20	48,80	0,88	90,3	90,7	90,7	7,0	2,5	3,4	0,05300	112,8	70
	2EG160L2C	18,50	2935	32,20	60,19	0,91	91,1	91,5	91,0	8,2	2,9	3,8	0,06200	130,2	70
	2EG180M2A	22,00	2955	39,00	71,10	0,89	91,4	91,6	90,6	7,9	2,6	3,6	0,07100	162,6	70

ELECTRICAL CHARACTERISTICS 400V 50Hz 1500 rpm

IE2

Voltage (V)	Type	Rated Values								Starting Values		Breakdown Torque	Moment of Inertia	B3 Motor Weight	Sound Pressure Level
		Power	Speed	Current	Torque	Power Factor	Efficiency % $\eta$			Current	Torque				
		kW	rpm	A	Nm	Cos $\phi$	4/4	3/4	1/2	$I_A/I_N$	$M_A/M_N$				
230/400	2EL071M4B	0,25	1425	0,71	1,68	0,69	74,0	73,5	70,5	4,4	2,0	3,0	0,00080	5,9	46
	2EL071M4C	0,37	1425	1,00	2,47	0,70	76,1	75,5	71,5	4,6	2,0	3,0	0,00096	6,7	46
	2EL080M4B	0,55	1440	1,45	3,65	0,71	77,1	76,7	75,0	5,2	2,0	3,0	0,00180	9,7	50
	2EL080M4C	0,75	1440	1,89	4,97	0,72	79,6	79,2	77,0	5,2	2,0	3,0	0,00220	10,5	50
	2EL090S4B	1,10	1440	2,60	7,30	0,75	81,4	81,4	80,5	5,6	2,2	3,1	0,00320	14,4	52
	2EL090L4C	1,50	1440	3,40	9,95	0,77	82,8	83,0	82,0	6,0	2,3	3,2	0,00390	17,2	52
	2EL100L4B	2,20	1445	4,85	14,60	0,78	84,3	85,3	84,2	6,0	2,1	3,2	0,00800	22,7	54
	2EL100L4C	3,00	1440	6,42	19,89	0,79	85,5	85,7	84,6	6,3	2,3	3,1	0,01100	24,2	54
400/690	2EL112M4C	4,00	1450	8,20	26,35	0,81	86,8	87,4	86,5	6,6	2,5	3,4	0,01300	32,0	58
	2EL132S4B	5,50	1455	11,05	36,10	0,82	87,7	88,6	88,0	6,7	2,6	3,2	0,03000	47,8	62
	2EL132M4C	7,50	1460	15,00	49,00	0,81	88,7	89,0	89,0	7,0	2,7	3,3	0,03500	54,8	62
	2EG160M4B	11,00	1465	21,30	71,70	0,83	89,8	90,3	89,5	6,9	2,4	3,0	0,06800	113,6	65
	2EG160L4C	15,00	1460	28,80	98,12	0,83	90,6	91,3	90,9	6,9	2,6	3,0	0,08500	131,9	65
	2EG180M4B	18,50	1465	34,90	120,60	0,84	91,2	91,5	91,4	6,9	2,5	3,0	0,12600	157,6	65
	2EG180L4C	22,00	1465	41,40	143,40	0,84	91,6	91,7	91,5	7,1	2,6	3,2	0,14000	174,4	65



## PERFORMANCE AND DIMENSIONS

ELECTRICAL CHARACTERISTICS 400V 50Hz 1000 rpm

IE2

Voltage (V)	Type	Rated Values								Starting Values		Breakdown Torque	Moment of Inertia	B3 Motor Weight	Sound Pressure Level
		Power	Speed	Current	Torque	Power Factor	Efficiency % $\eta$			Current	Torque				
		kW	rpm	A	Nm	Cos $\phi$	4/4	3/4	1/2	I <sub>A</sub> /I <sub>N</sub>	M <sub>A</sub> /M <sub>N</sub>				
230/400	2EL071M6B	0,18	920	0,60	1,87	0,67	64,5	63,0	57,0	3,2	1,9	2,3	0,00075	5,9	42
	2EL071M6C	0,25	920	0,78	2,59	0,69	66,5	66,0	61,0	3,3	1,9	2,3	0,00092	6,6	42
	2EL080M6A	0,37	925	1,08	3,82	0,69	71,4	71,5	70,0	4,0	2,0	2,6	0,00190	9,1	45
	2EL080M6B	0,55	932	1,50	5,64	0,72	73,5	74,0	71,0	4,2	2,1	2,6	0,00240	9,9	45
	2EL090S6A	0,75	940	2,00	7,62	0,71	75,9	76,1	73,1	4,1	2,0	2,6	0,00360	13,3	48
	2EL090L6B	1,10	940	2,90	11,18	0,70	78,1	78,3	75,0	4,3	2,1	2,6	0,00400	14,8	48
	2EL100L6A	1,50	950	3,72	15,00	0,73	79,8	80,2	79,5	4,5	2,1	2,6	0,01000	20,2	52
	2EL112M6A	2,20	960	5,32	21,90	0,73	81,8	82,0	81,5	5,3	2,1	2,7	0,01400	25,0	56
400/690	2EL132S6A	3,00	970	6,85	29,60	0,76	83,3	84,0	83,0	5,6	2,0	2,8	0,02800	42,0	60
	2EL132M6B	4,00	970	8,80	39,38	0,77	85,2	85,7	85,3	5,2	2,1	2,6	0,03400	46,0	60
	2EL132M6C	5,50	965	12,00	54,40	0,77	86,0	87,2	87,0	5,7	2,1	2,7	0,03900	51,0	60
	2EG160M6B	7,50	972	16,30	73,68	0,76	87,2	88,1	87,7	5,6	2,4	2,7	0,07900	113,2	63
	2EG160L6D	11,00	970	22,95	108,30	0,78	88,7	90,0	89,9	6,0	2,5	2,9	0,10500	136,1	63
	2EG180L6D	15,00	975	31,00	146,90	0,78	89,7	90,5	90,2	6,2	2,5	2,9	0,18000	175,2	64

آتور صنعت  
ATOORSANAT

## PERFORMANCE AND DIMENSIONS

ELECTRICAL CHARACTERISTICS 400V 50Hz 3000 rpm

IE3

Voltage (V)	Type	Rated Values								Starting Values		Breakdown Torque	Moment of Inertia	B3 Motor Weight	Sound Pressure Level
		Power	Speed	Current	Torque	Power Factor	Efficiency % $\eta$			Current	Torque				
		kW	rpm	A	Nm	Cos $\phi$	4/4	3/4	1/2	$I_A/I_N$	$M_A/M_N$				
230/400	3EL071M2B	0,37	2830	0,86	1,25	0,81	76,6	77,0	75,0	6,0	2,8	3,0	0,00086	6,2	53
	3EL071M2C	0,55	2830	1,19	1,86	0,84	79,4	80,2	78,8	6,1	2,9	3,3	0,00096	7,2	53
	3EL080M2B	0,75	2880	1,59	2,49	0,84	80,7	82,0	81,5	6,7	3,0	3,6	0,00140	9,6	54
	3EL080M2C	1,10	2880	2,26	3,64	0,85	82,7	83,0	82,4	6,8	3,1	3,8	0,00165	10,9	54
	3EL090S2B	1,50	2900	2,97	4,94	0,86	84,8	85,4	84,2	7,6	3,1	3,9	0,00220	15,6	59
	3EL090L2C	2,20	2900	4,25	7,24	0,87	85,9	86,8	86,1	7,2	3,0	3,8	0,00310	17,0	59
	3EL100L2C	3,00	2915	5,58	9,83	0,89	87,1	87,6	86,9	7,9	3,0	4,1	0,00540	23,3	62
400/690	3EL112M2C	4,00	2915	7,28	13,10	0,90	88,1	88,8	88,2	7,5	2,6	3,9	0,01100	29,1	65
	3EL132S2B	5,50	2945	9,90	17,83	0,90	89,2	89,0	88,6	8,9	2,9	3,9	0,02200	44,4	67
	3EL132S2C	7,50	2945	13,20	24,32	0,91	90,1	90,5	89,7	8,4	2,6	4,0	0,02900	51,5	67
	3EG160M2B	11,00	2950	19,70	35,60	0,88	91,2	91,0	90,5	8,0	2,6	3,9	0,05300	113,6	69
	3EG160M2C	15,00	2950	25,90	48,55	0,91	91,9	92,1	91,6	8,9	3,1	4,2	0,06200	131,1	69
	3EG160L2D	18,50	2945	31,70	60,00	0,91	92,4	92,7	92,3	8,9	3,1	4,2	0,07000	135,2	69
	3EG180M2B	22,00	2957	38,10	71,05	0,90	92,7	92,9	92,0	8,6	2,6	3,9	0,08200	178,2	70

ELECTRICAL CHARACTERISTICS 400V 50Hz 1500 rpm

IE3

Voltage (V)	Type	Rated Values								Starting Values		Breakdown Torque	Moment of Inertia	B3 Motor Weight	Sound Pressure Level
		Power	Speed	Current	Torque	Power Factor	Efficiency % $\eta$			Current	Torque				
		kW	rpm	A	Nm	Cos $\phi$	4/4	3/4	1/2	$I_A/I_N$	$M_A/M_N$				
230/400	3EL071M4C	0,25	1435	0,67	1,66	0,71	76,0	75,4	71,5	5,4	2,2	3,0	0,00096	6,8	45
	3EL071M4D	0,37	1435	0,97	2,46	0,70	78,5	78,2	75,0	5,5	2,2	3,1	0,00120	7,5	45
	3EL080M4C	0,55	1450	1,34	3,62	0,73	80,8	80,4	77,0	5,9	2,1	3,1	0,00220	10,5	50
	3EL080M4D	0,75	1450	1,77	4,94	0,74	82,5	82,3	80,0	6,2	2,5	3,4	0,00360	11,6	50
	3EL090S4C	1,10	1450	2,46	7,25	0,76	84,5	84,3	82,0	7,0	2,6	3,6	0,00390	16,3	51
	3EL090L4D	1,50	1450	3,30	9,88	0,77	85,3	85,2	83,0	7,2	2,8	3,8	0,00480	18,0	51
	3EL100L4C	2,20	1450	4,65	14,49	0,79	86,7	87,2	86,0	7,2	2,8	3,6	0,01100	24,4	53
	3EL100L4D	3,00	1450	6,26	19,76	0,79	87,7	88,0	87,0	7,2	2,8	3,6	0,01300	26,7	53
400/690	3EL112M4D	4,00	1460	8,05	26,16	0,81	88,6	88,4	87,5	7,4	2,8	3,8	0,01500	33,9	58
	3EL132S4C	5,50	1460	10,65	36,00	0,83	89,6	90,2	90,0	7,4	2,8	3,4	0,03500	53,4	61
	3EL132M4D	7,50	1465	14,40	48,90	0,83	90,4	90,4	89,4	7,9	3,0	3,8	0,04200	59,5	61
	3EG160M4C	11,00	1470	21,00	71,46	0,83	91,4	91,7	91,0	7,6	2,8	3,3	0,08500	127,4	63
	3EG160L4D	15,00	1470	28,70	97,45	0,82	92,1	92,4	91,9	7,8	2,8	3,6	0,09500	136,4	63
	3EG180M4C	18,50	1475	35,00	119,80	0,82	92,6	93,2	92,9	7,7	3,0	3,3	0,14000	173,2	64
	3EG180L4D	22,00	1470	41,40	142,92	0,82	93,0	93,7	93,7	8,0	3,0	3,4	0,16000	186,8	64

## PERFORMANCE AND DIMENSIONS

ELECTRICAL CHARACTERISTICS 400V 50Hz 1000 rpm

IE3

Voltage (V)	Type	Rated Values								Starting Values		Breakdown Torque	Moment of Inertia	B3 Motor Weight	Sound Pressure Level
		Power	Speed	Current	Torque	Power Factor	Efficiency % $\eta$			Current	Torque				
		kW	rpm	A	Nm	Cos $\phi$	4/4	3/4	1/2	I <sub>A</sub> /I <sub>N</sub>	M <sub>A</sub> /M <sub>N</sub>				
230/400	3EL071M6C	0,18	930	0,55	1,85	0,69	68,0	67,4	62,6	3,6	2,0	2,4	0,00092	6,7	41
	3EL071M6D	0,25	930	0,77	2,57	0,67	70,0	69,7	66,0	3,6	2,2	2,5	0,00105	7,5	41
	3EL080M6B	0,37	930	1,03	3,80	0,70	74,0	73,8	70,0	4,4	2,1	2,6	0,00240	9,8	43
	3EL080M6C	0,55	935	1,47	5,62	0,70	77,2	77,3	74,4	4,3	2,2	2,7	0,00270	10,6	43
	3EL090S6B	0,75	945	1,96	7,58	0,70	78,9	79,5	77,6	4,7	2,2	2,7	0,00400	14,6	46
	3EL090L6C	1,10	940	2,75	11,20	0,71	81,0	80,8	79,4	5,0	2,2	2,7	0,00480	17,0	46
	3EL100L6B	1,50	955	3,50	15,00	0,75	82,5	82,7	81,4	5,3	2,1	2,8	0,01400	22,5	50
	3EL112M6B	2,20	965	4,95	21,70	0,76	84,3	84,5	83,5	5,5	2,2	3,0	0,01900	27,2	56
400/690	3EL132S6B	3,00	970	6,55	29,40	0,77	85,6	85,5	84,5	6,2	2,1	3,0	0,03400	46,5	58
	3EL132M6C	4,00	970	8,52	39,40	0,78	86,8	87,0	85,5	6,2	2,2	3,0	0,03900	51,0	58
	3EL132M6D	5,50	970	11,55	54,15	0,78	88,0	88,9	88,5	6,2	2,2	3,0	0,04200	56,0	58
	3EG160M6D	7,50	972	15,55	73,68	0,78	89,1	89,4	88,4	6,3	2,6	3,0	0,10500	134,8	61
	3EG160L6E	11,00	972	22,90	108,07	0,77	90,3	90,9	90,5	6,6	2,9	3,3	0,13000	143,6	62
	3EG180L6E	15,00	975	30,80	146,92	0,77	91,2	91,6	91,0	6,7	2,9	3,1	0,20000	187,2	63

آتور صنعت  
ATOORSANAT

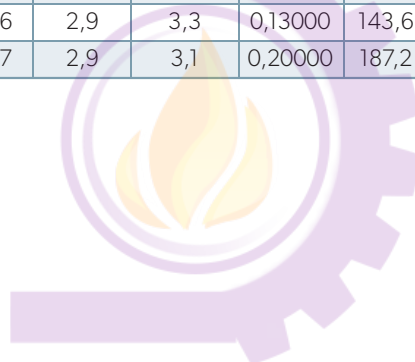

## PERFORMANCE AND DIMENSIONS

### DIMENSIONS B3

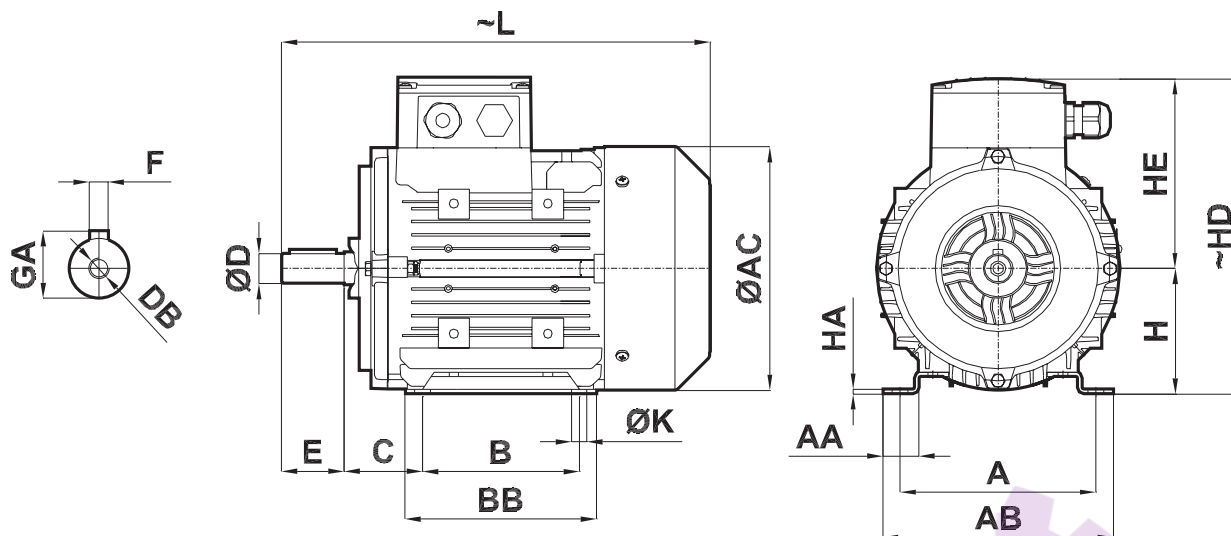

Frame Size	D <sup>[1]</sup>	E	L	AC	H <sup>[2]</sup>	HE	HD	F	GA	DB	C	ØK	B	BB	HA	AA	A	AB
071	14	30	241	137	71	112	183	5	16	M5	45	7	90	110	3	19	112	128
080	19	40	274	155	80	121	201	6	21,5	M6	50	10	100	122	3	23	125	147
090S	24	50	325	176	90	133	223	8	27	M8	56	10	100	151	4	27	140	166
090L	24	50	325	176	90	133	223	8	27	M8	56	10	125	151	4	27	140	166
100	28	60	370,5	193	100	147	247	8	31	M10	63	12	140	170	4	31	160	191
112	28	60	391	215	112	158	270	8	31	M10	70	12	140	177	4	36	190	215
132S	38	80	495	257	132	179	311	10	41	M12	89	12	140	212	5	34	216	246
132M	38	80	495	257	132	179	311	10	41	M12	89	12	178	212	5	34	216	246
160M	42	110	605	316	160	224	384	12	45	M16	108	14,5	210	323	15	49,5	254	295
160L	42	110	605	316	160	224	384	12	45	M16	108	14,5	254	323	15	49,5	254	295
180M	48	110	693	354	180	240	420	14	51,5	M16	121	14,5	241	319	15	50	279	324
180L	48	110	693	354	180	240	420	14	51,5	M16	121	14,5	279	319	15	50	279	324

[1] Tolerance "j6" up to 28mm, "k6" over 28mm EN 50347

[2] Tolerance "-0.5mm" EN 50347

## PERFORMANCE AND DIMENSIONS

### DIMENSIONS B14 - B34

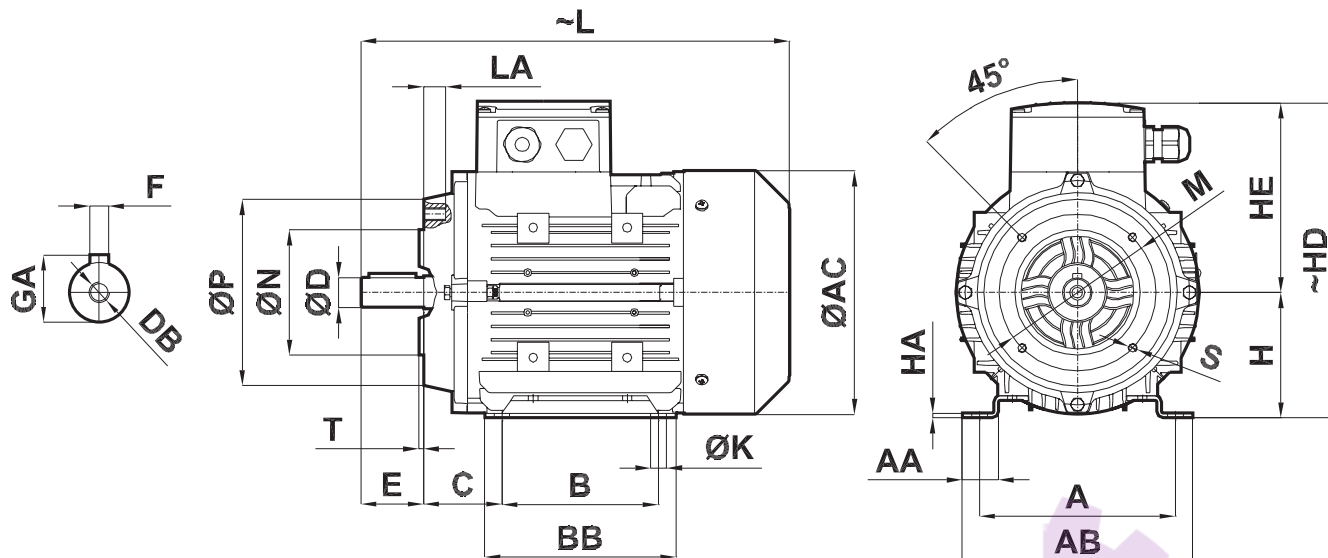

Frame Size	D <sup>[1]</sup>	N <sup>[2]</sup>	P	E	T	LA	L	AC	S	M	H <sup>[3]</sup>	HE	HD	F	GA	DB	C	ØK	B	BB	HA	AA	A	AB
071	14	70	106,5	30	2,5	12	241	137	M6	85	71	112	183	5	16	M5	45	7	90	110	3	19	112	128
080	19	80	118,5	40	3	12	274	155	M6	100	80	121	201	6	21,5	M6	50	10	100	122	3	23	125	147
090S	24	95	136,5	50	3	15	325	176	M8	115	90	133	223	8	27	M8	56	10	100	151	4	27	140	166
090L	24	95	136,5	50	3	15	325	176	M8	115	90	133	223	8	27	M8	56	10	125	151	4	27	140	166
100	28	110	159,5	60	3,5	17	370,5	193	M8	130	100	147	247	8	31	M10	63	12	140	170	4	31	160	191
112	28	110	159,5	60	3,5	17	391	215	M8	130	112	158	270	8	31	M10	70	12	140	177	4	36	190	215
132S	38	130	200	80	3,5	20	495	257	M10	165	132	179	311	10	41	M12	89	12	140	212	5	34	216	246
132M	38	130	200	80	3,5	20	495	257	M10	165	132	179	311	10	41	M12	89	12	178	212	5	34	216	246
160M	42	180	250	110	4	30	605	316	M12	215	160	224	384	12	45	M16	108	14,5	210	323	15	49,5	254	295
160L	42	180	250	110	4	30	605	316	M12	215	160	224	384	12	45	M16	108	14,5	254	323	15	49,5	254	295

[1] Tolerance "j6" up to 28mm, "k6" over 28mm EN 50347

[2] Tolerance "j6" EN 50347

[3] Tolerance "-0.5mm" EN 50347



## PERFORMANCE AND DIMENSIONS

### DIMENSIONS B5 - B35

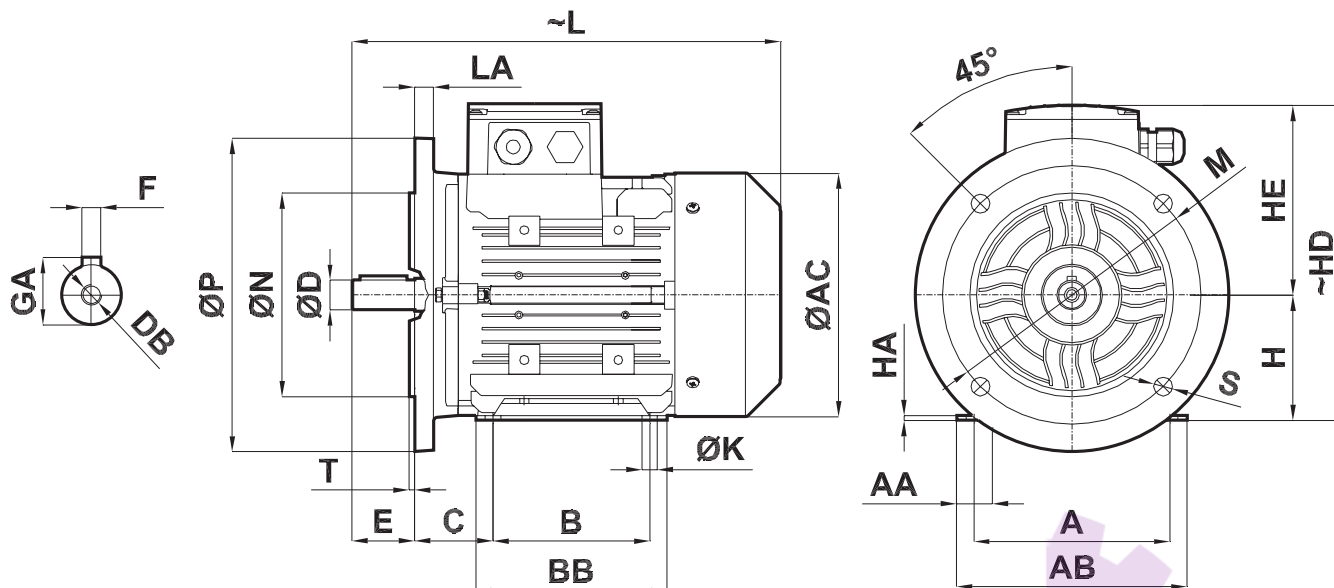



Frame Size	D <sup>[1]</sup>	N <sup>[2]</sup>	P	E	T	LA	L	AC	S	M	H <sup>[3]</sup>	HE	HD	F	GA	DB	C	ØK	B	BB	HA	AA	A	AB
071	14	110	160	30	3,5	8	241	137	10	130	71	112	183	5	16	M5	45	7	90	110	3	19	112	128
080	19	130	200	40	3,5	12	274	155	12	165	80	121	201	6	21,5	M6	50	10	100	122	3	23	125	147
090S	24	130	200	50	3,5	12	325	176	12	165	90	133	223	8	27	M8	56	10	100	151	4	27	140	166
090L	24	130	200	50	3,5	12	325	176	12	165	90	133	223	8	27	M8	56	10	125	151	4	27	140	166
100	28	180	250	60	4	15	370,5	193	14,5	215	100	147	247	8	31	M10	63	12	140	170	4	31	160	191
112	28	180	250	60	4	15	391	215	14,5	215	112	158	270	8	31	M10	70	12	140	177	4	36	190	215
132S	38	230	300	80	4	20	495	257	14,5	265	132	179	311	10	41	M12	89	12	140	212	5	34	216	246
132M	38	230	300	80	4	20	495	257	14,5	265	132	179	311	10	41	M12	89	12	178	212	5	34	216	246
160M	42	250	350	110	5	20	605	316	18,5	300	160	224	384	12	45	M16	108	14,5	210	323	15	49,5	254	295
160L	42	250	350	110	5	20	605	316	18,5	300	160	224	384	12	45	M16	108	14,5	254	323	15	49,5	254	295
180M	48	250	350	110	5	14	693	354	18,5	300	180	240	420	14	51,5	M16	121	14,5	241	319	15	50	279	324
180L	48	250	350	110	5	14	693	354	18,5	300	180	240	420	14	51,5	M16	121	14,5	279	319	15	50	279	324

[1] Tolerance "j6" up to 28mm, "k6" over 28mm EN 50347

[2] Tolerance "j6" EN 50347

[3] Tolerance "-0.5mm" EN 50347

## OVERHUNG LOADS

HORIZONTAL MOUNTING - Permissible Overhung Loads		
Mounting Positions IM: B3, B5, B6, B7, B8, B14, B34, B35		
Frame Size	Fa=0	
		
<b>2 Poles 3000 rpm</b>	<b>Fr<sub>0</sub> [N]</b>	<b>Fr<sub>max</sub> [N]</b>
71	380	340
80	640	550
90	750	660
100	1000	900
112	1000	910
132	1520	1220
160	2800	2300
180	3250	2650
<b>4 Poles 1500 rpm</b>	<b>Fr<sub>0</sub> [N]</b>	<b>Fr<sub>max</sub> [N]</b>
71	520	440
80	800	700
90	950	800
100	1300	1100
112	1300	1100
132	1950	1600
160	3300	2500
180	4100	3400
<b>6 Poles 1000 rpm</b>	<b>Fr<sub>0</sub> [N]</b>	<b>Fr<sub>max</sub> [N]</b>
71	580	500
80	870	800
90	1090	900
100	1500	1250
112	1500	1250
132	2200	1800
160	4050	3200
180	4720	3830

### Overhung Load (F<sub>R</sub>):

Overhung load can be calculated according to below written formulae. Calculated overhung load must be below permissible overhung loads given at tables (F<sub>R</sub> < F<sub>Rx</sub>).

$$F_R = k \cdot \frac{P}{D \cdot n} \cdot 10^7 \text{ (N)}$$

- P: Motor power (kW)  
D: Pulley diameter (mm)  
n: Motor speed (rpm)  
k: Overhung load factor
- Spur gears, chain drives with low speed = 2,1
  - Trigger belts = 2,5
  - V type belts = 5

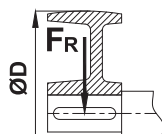

### Correction of Permissible Overhung Load (F<sub>Rx</sub>):

If the overhung load is applied between points x<sub>0</sub> and x<sub>max</sub>, the permissible overhung load can be corrected with the following formulae.

$$F_{R_x} = F_{R_0} - \frac{x}{E} (F_{R_0} - F_{R_{max}})$$

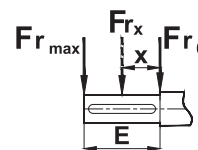

F<sub>R</sub> < F<sub>Rx</sub>: Calculated overhung load must be below permissible overhung loads given at tables.

Fa: Axial load  
F<sub>R0</sub>: Permissible overhung load at shaft shoulder  
F<sub>Rmax</sub>: Permissible overhung load at shaft end point  
Permissible loads are calculated for L<sub>n10</sub> 20000 h bearing lifetimes according to ISO 281

## AXIAL LOADS

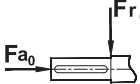
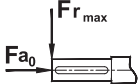
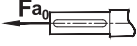
HORIZONTAL MOUNTING - Permissible Axial Loads				
Mounting Positions IM: B3, B5, B6, B7, B8, B14, B34, B35				
Frame Size	Push			Pull
	Fr = 0	Fr = Fr <sub>0</sub>	Fr = Fr <sub>max</sub>	Fr = 0
				
<b>2 Poles 3000 rpm</b>	Fa <sub>0</sub> [N]	Fa <sub>0</sub> [N]	Fa <sub>0</sub> [N]	Fa <sub>0</sub> [N]
71	110	110	110	250
80	190	190	190	400
90	210	210	210	440
100	270	270	270	620
112	270	270	270	620
132	380	380	370	940
160	2280	1060	1020	1800
180	2660	1250	1250	2100
<b>4 Poles 1500 rpm</b>	Fa <sub>0</sub> [N]	Fa <sub>0</sub> [N]	Fa <sub>0</sub> [N]	Fa <sub>0</sub> [N]
71	110	110	110	380
80	190	190	190	590
90	210	210	210	650
100	300	300	300	870
112	300	300	300	900
132	400	400	400	1350
160	2280	1400	1400	2570
180	2660	1570	1500	3000
<b>6 Poles 1000 rpm</b>	Fa <sub>0</sub> [N]	Fa <sub>0</sub> [N]	Fa <sub>0</sub> [N]	Fa <sub>0</sub> [N]
71	110	110	110	450
80	190	190	190	720
90	210	210	210	810
100	290	290	290	1090
112	290	290	290	1090
132	380	380	380	1620
160	2480	1540	1520	3000
180	2750	1780	1700	3500

Fa<sub>0</sub>: Permissible axial load

Fr: Overhung Load

Fr<sub>0</sub>: Permissible overhung load at shaft shoulder

Fr<sub>max</sub>: Permissible overhung load at shaft end point

Permissible loads are calculated for L<sub>n10</sub> 20000 h bearing lifetimes according to ISO 281.



## AXIAL LOADS

### VERTICAL MOUNTING – Shaft Extension Pointing Upwards - Permissible Axial Loads

Mounting Positions IM: V3, V6, V19, V35, V37

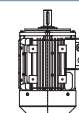

Frame Size	Push			Pull
	$F_r=0$	$F_r = F_{r_0}$	$F_r = F_{r_{max}}$	$F_r=0$
<b>2 Poles 3000 rpm</b>	$F_{a_0}$ [N]	$F_{a_0}$ [N]	$F_{a_0}$ [N]	$F_{a_0}$ [N]
71	100	100	100	290
80	170	170	170	460
90	180	180	180	520
100	250	250	250	680
112	250	250	250	680
132	300	300	300	1100
160	2080	680	690	2160
180	2410	780	770	2570
<b>4 Poles 1500 rpm</b>	Push			Pull
	$F_{a_0}$ [N]	$F_{a_0}$ [N]	$F_{a_0}$ [N]	$F_{a_0}$ [N]
71	95	95	95	390
80	160	160	160	580
90	170	170	170	660
100	210	210	210	930
112	210	210	210	930
132	240	240	240	1500
160	2500	1150	1150	2160
180	2900	1250	1250	2570
<b>6 Poles 1000 rpm</b>	Push			Pull
	$F_{a_0}$ [N]	$F_{a_0}$ [N]	$F_{a_0}$ [N]	$F_{a_0}$ [N]
71	95	95	95	480
80	160	160	160	780
90	170	170	170	880
100	230	230	230	1180
112	210	210	210	1200
132	250	250	250	1850
160	2980	1360	1260	3300
180	3400	1560	1560	3800

$F_{a_0}$  : Permissible axial load

$F_r$ : Overhung Load

$F_{r_0}$  : Permissible overhung load at shaft shoulder

$F_{r_{max}}$  : Permissible overhung load at shaft end point

Permissible loads are calculated for  $L_{h10}$  20000 h bearing lifetimes according to ISO 281.

## AXIAL LOADS

### VERTICAL MOUNTING – Shaft Extension Pointing Downwards - Permissible Axial Loads

Mounting Positions IM: V1, V5, V15, V17, V18

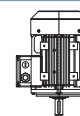

Frame Size	Push			Pull
	$Fr = 0$	$Fr = Fr_0$	$Fr = Fr_{max}$	$Fr = 0$
<b>2 Poles 3000 rpm</b>	$Fa_0$ [N]	$Fa_0$ [N]	$Fa_0$ [N]	$Fa_0$ [N]
71	130	130	130	260
80	220	220	220	420
90	250	250	250	450
100	330	330	330	560
112	340	340	340	560
132	490	490	490	820
160	2600	1300	1280	1650
180	3070	1550	1550	1900
<b>4 Poles 1500 rpm</b>	$Fa_0$ [N]	$Fa_0$ [N]	$Fa_0$ [N]	$Fa_0$ [N]
71	130	130	130	370
80	220	220	220	580
90	260	260	260	620
100	380	370	370	810
112	410	400	400	810
132	580	570	570	1180
160	3500	1850	1840	2200
180	4000	1980	1950	2600
<b>6 Poles 1000 rpm</b>	$Fa_0$ [N]	$Fa_0$ [N]	$Fa_0$ [N]	$Fa_0$ [N]
71	130	130	130	440
80	220	220	220	720
90	250	250	250	770
100	360	360	360	1030
112	390	390	390	1000
132	560	560	560	1450
160	3100	1920	1900	2800
180	3600	2260	2250	3300

$Fa_0$ : Permissible axial load

Fr: Overhung Load

$Fr_0$ : Permissible overhung load at shaft shoulder

$Fr_{max}$ : Permissible overhung load at shaft end point

Permissible loads are calculated for  $L_{h10}$  20000 h bearing lifetimes according to ISO 281.

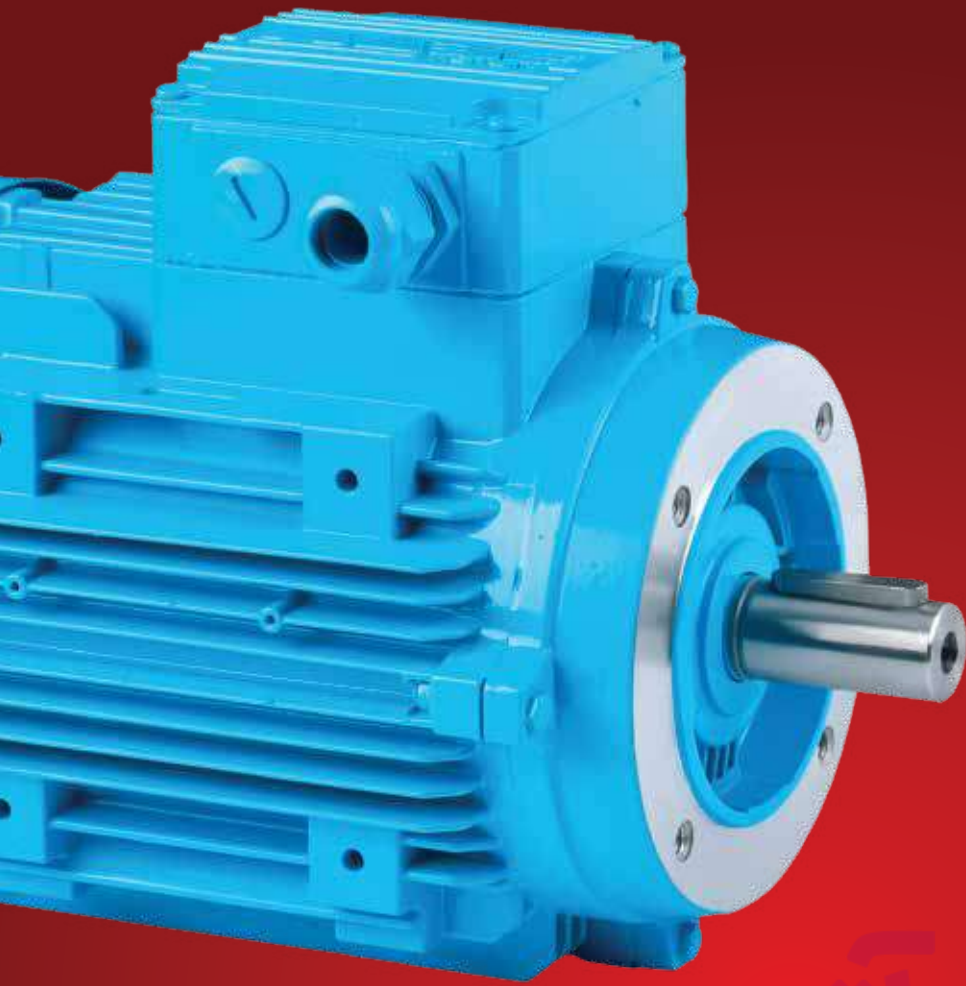

آتور صنعت  
ATOORSANAT

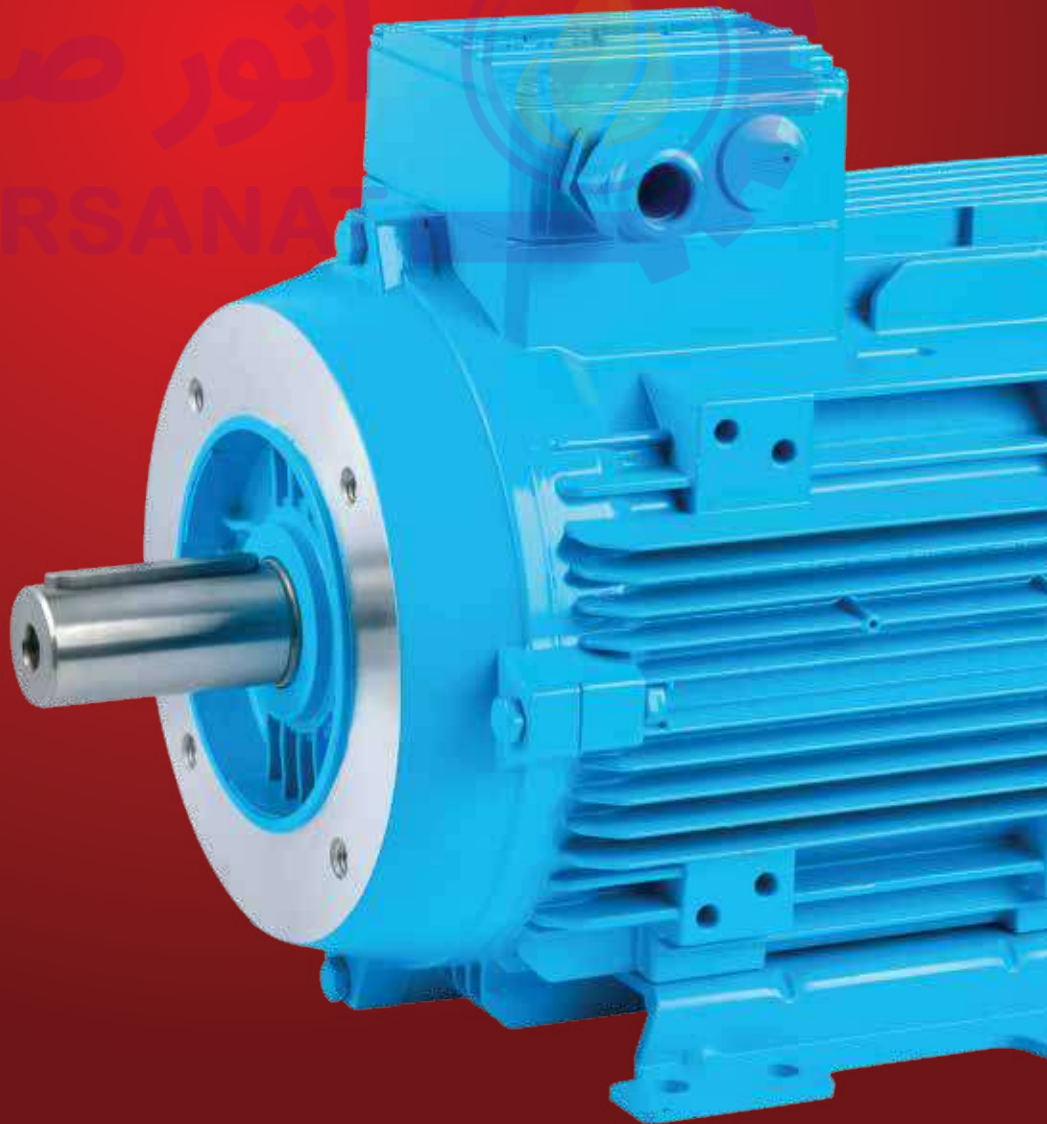

آتور صنعت  
**ELK**  
MOTOR

ATOORSANAT

**MES Elektromekanik Döküm San. ve Tic. A.Ş.**

G.O. Paşa Mah. 1. Cad. No: 125 2. Organize Sanayi Bölgesi 59500  
Çerkezköy / Tekirdağ / TÜRKİYE  
Tel/Phone: +90 282 726 92 94-96 - Faks/Fax: +90 282 726 90 42  
www.elkmotor.com.tr / elkmotor@elkmotor.com.tr

**ELK Motor San. ve Tic. A.Ş.**

Atatürk Mah. Lozan Cad. No:17  
34522 Esenyurt / İstanbul / TÜRKİYE  
Tel/Phone: +90 444 95 60 - Faks/Fax: +90 212 886 54 58  
www.elkmotor.com.tr / elkmotor@elkmotor.com.tr

**YILMAZ REDÜKTÖR GmbH**

Mollsfeld 3 40670 Meerbusch / GERMANY  
Phone: +49 2159 92 84 361 Fax: +49 2159 92 84 364  
www.yilmazreduktor.de