



آتور صنعت
ATOORSANAT



Vacuum pumps and systems



YAĞ SİRKÜLASYONLU VAKUM POMPALARI
ROTARY VANE VACUUM PUMPS



*We vacuum
the
world*



zinisan.com.tr

KATALOG / CATALOG - 2013

VAKUM TEKNOLOJİLERİ
ZINISAN VAKUM POMPA ve MAKİNA LTD.

ZYVP/016

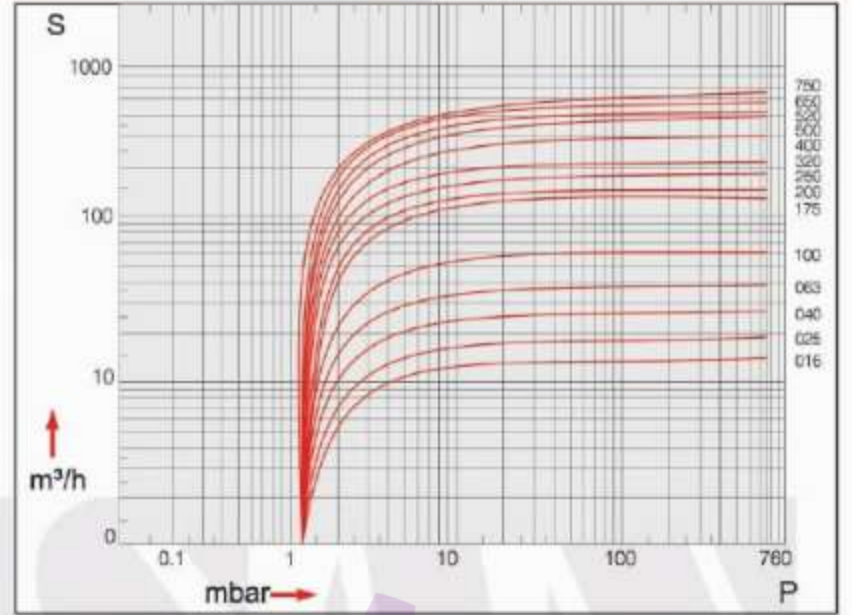

ZYVP/025-040



Geniş kapasite seçenekleri ve yüksek vakum verimi ile ZYVP serisi vakum pompaları çok geniş kullanım alanına sahiptir. ZINISAN ZYVP pompalar kesintisiz çalışmak için tasarlanmıştır ve pek çok sektörde uzun yıllar başarıyla kullanılmaktadır.

Dayanıklısıdır ; Yüksek kaliteli hammaddeler ve en güncel bilgisayar destekli üretim sistemleri kullanılarak üretilen pompalar, zorlu çalışma ortamlarında en yüksek verimi sağlar. Direkt motor tahriki ile güç aktarım elemanlarından kaynaklanan problemler ortadan kaldırılmıştır. Dahili çekvalf sistemi, her türlü uygulama ortamında kesin sızdırmazlık sağlar.

Kolay bakım ; Kompakt tasarım, etkin hava soğutma tasarımı ve bakım noktalarına kolay erişim bakımın hızlı, kolay ve uzun aralıklarla yapılmasına olanak sağlar. Rutin yağ filtre değişimleri haricinde önleyici bakım gerektirmez.

ZYVP/063-100



Teknik Özellikler / Technical Data		ZYVP 016	ZYVP 025	ZYVP 040	ZYVP 063
Nominal Kapasite <i>Nominal Displacement</i>	50 Hz m ³ /h	16	25	40	63
	60 Hz m ³ /h	19	30	48	76
Vakum Verimi <i>Ultimate Pressure</i>	mbar	2	2	2	2
Motor Gücü <i>Nominal Motor Rating</i>	50 Hz kW	0,37	0,75	1,1	1,5
	60 Hz kW	0,55	1,1	1,5	2,2
Motor Devri <i>Nominal Motor Speed</i>	50 Hz d/d	1500	1500	1500	1500
	60 Hz rpm	1800	1800	1800	1800
Ses Seviyesi - EN 2151 <i>Noise Level - EN 2151</i>	50 Hz db(A)	53	60	63	64
	60 Hz db(A)	55	63	66	66
Çalışma Sıcaklığı <i>Operating Temperature</i>	50 Hz °C	80	80	82	84
	60 Hz °C	83	85	90	92
Yağ Miktarı <i>Oil Filling</i>	lt	0,5	1,5	1,5	3
Yaklaşık Ağırlık <i>Approximate Weight</i>	kg	21	37	44	59

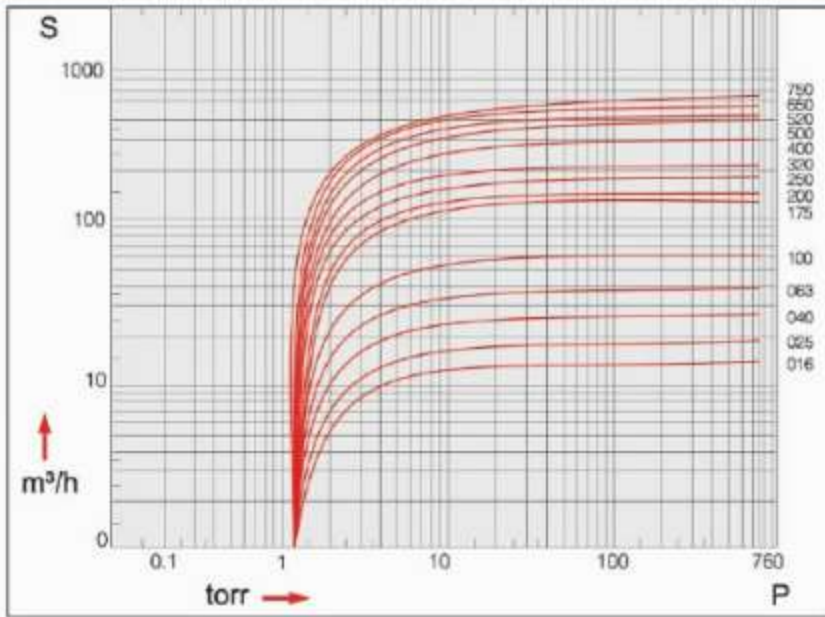

The range of capacity options and high ultimate pressure make ZINISAN ZYVP series vacuum pumps an ideal solution for even the most demanding applications. Designed for continuous operation in industry, the ZYVP series have been successfully used in many applications for long years.

Reliable ; High quality materials and implementing up to date computerized manufacturing methods ensure the optimum performance in all kinds of work environments. Direct driven by a standart electric motor eliminates the problems caused by transmission components. The integrated check-valve prevents air admittance into the vacuum chamber.

Easy to Service ; Compact design, air cooling and easy access allows rapid and simple servicing with long periods between services. No preventative maintenance apart from routine oil changes is required.

ZYVP	ZYVP	ZYVP	ZYVP	ZYVP	ZYVP	ZYVP	ZYVP	ZYVP	ZYVP
100	175	200	250	320	400	500	520	650	750
100	175	200	250	320	400	500	520	650	750
120	195	240	300	380	480	600	630	760	890
2	2	2	2	2	2	2	2	2	2
2,2	4,0	4	5,5	7,5	7,5	11	15	15,0	18,5
3,0	5,5	5,5	7,5	10,0	10,0	15	18,5	18,5	22
1500	1500	1500	1500	1500	1500	1500	1000	1000	1000
1800	1800	1800	1800	1800	1800	1800	1150	1150	1150
65	70	71	73	74	77	79	79	77	85
68	73	73	76	76	79	81	81	79	87
84	82	83	87	88	86	92	88	80	81
93	90	92	96	98	95	98	90	86	87
3	6	6	6	6,5	6,5	8	18	18	22
76	147	176	196	213	236	268	494	580	667

ZYVP/175-200-250



ZYVP/320-400-500



ZYVP/520-650-750



ÇALIŞMA PRENSİBİ / principle of operation

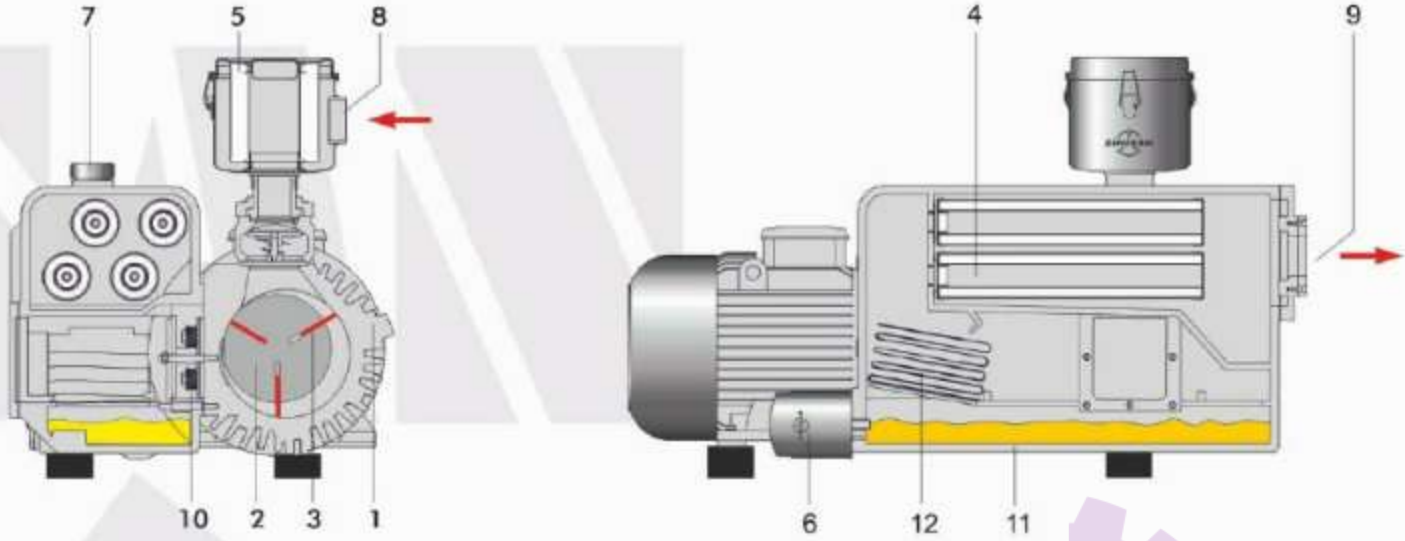

- | | | |
|------------------------------------|--------------------------------------|--|
| 1- Gövde / Cylinder | 5- Hava filtresi / Inlet Filter | 9- Egzos çıkışı / Exhaust Port |
| 2- Rotor / Rotor | 6- Yağ filtresi / Oil Filter | 10- Egzos subabı / Exhaust Valve |
| 3- Palet / Vane | 7- Yağ dolum noktası / Oil Fill Plug | 11- Pompa yağı / Oil Sump |
| 4- Egzos filtresi / Exhaust Filter | 8- Emiş ağız / Inlet Port | 12- Buhar yoğunlaştırıcı / Mist Eliminator |

Çalışma Prensibi :

ZİNİSAN ZYVP serisi yağ sirkülasyonlu vakum pompaları döner palet prensibiyle vakum üretir. Gövdenin (1) içine eksenal olarak kaçık yerleştirilen rotor (2) motor tahriği ile merkezkaç kuvveti oluşturur. Bu kuvvet rotor üzerindeki kanallarda serbest hareket eden paletleri (3) gövde iç yüzeyine doğru iter. Paletler gövde ve rotor arasında bulunan hilal kesitli alanı odacıklara böler. Bu odacıklar dönerek emiş noktasına geldiğinde gaz (hava) emilir, hareketin devamında emilen gaz sıkıştırılır ve son olarak yağ karterine itilir. Gövde içinde oluşan vakum, karterdeki yağın devamlı olarak sirkülasyon edilmesini sağlar. Yağ karterine iletilen hava ve yağ karışımı yağ yoğunlaştırıcısı, egsoz filtreleri (4) ve yerçekimi yardımıyla ayrıştırılarak, hava egsoz çıkışından atılır.

Uygulamalar

- Ambalaj ve paketleme
- Gıda sektörü
- Mermer ve doğaltaş sektörü
- Kaldırma ve taşıma sistemleri
- Medikal teknoloji
- Merkezi vakum sistemleri
- Çevre teknolojileri
- Gemi inşa sektörü
- Ağaç işleme
- Plastik sektörü
- Seramik ve tuğla üretimi
- Atık su transferi
- Tekstil sektörü
- Meşrubat sektörü
- Kağıt Sektörü
- Cam Sektörü

Principle of operation :

ZINISAN ZYVP series vacuum pumps work according to the rotary vane principle. An eccentrically installed rotor (2) rotates in the cylinder. The centrifugal force generated by the rotation pushes the vanes (3) which slide in slots in the rotor, towards the cylinder wall. The vanes separate the space between the rotor and the cylinder in chambers. When the chambers are connected to the inlet channel, gas is sucked, compressed by the next rotation and pushed into the oil separator. Differential pressure constantly causes oil to be passed into the compression chambers. The oil and medium are then discharged into the oil separator and then separated from the exhaust air by the exhaust filters (4) and gravity. Oil collects on the bottom of the oil reservoir and is passed into the chamber again.

Applications

- Packaging industry
- Food industry
- Marble and stone processing
- Transport and lifting systems
- Medical technology
- Central vacuum systems
- Environmental technology
- Ship building industry
- Woodworking
- Plastic industry
- Ceramics and brick industry
- Sewage transfer
- Textile industry
- Beverage industry
- Paper industry
- Glass industry

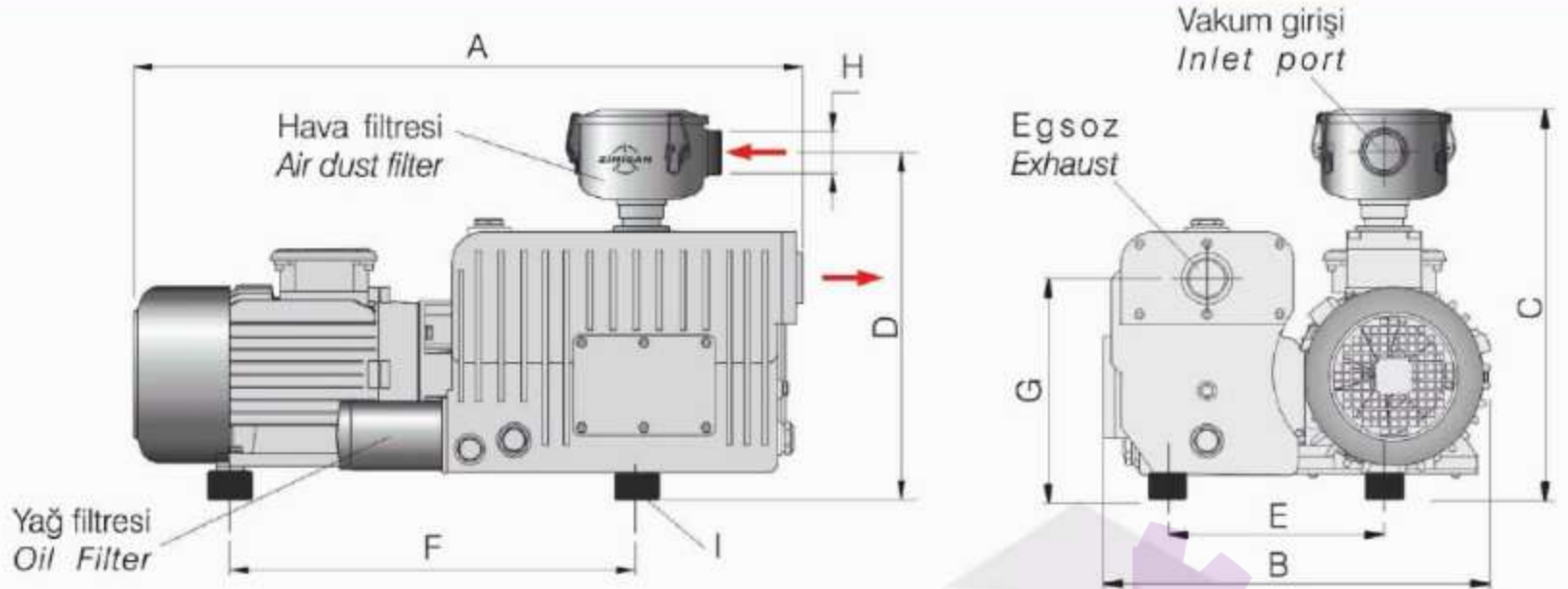

Ölçüler / Dimensions

DIMENSIONS	A	B	C	D	E	F	G	H	I	DIMENSIONS
ZYVP-016	490	230	310	260	130	292	170	G3/4"	M6	ZYVP-016
ZYVP-025	615	320	395	350	140	330	235	G11/4"	M8	ZYVP-025
ZYVP-040	655	320	395	350	140	370	235	G11/4"	M8	ZYVP-040
ZYVP-063	650	420	415	370	230	362	245	G11/4"	M8	ZYVP-063
ZYVP-100	730	420	415	370	230	448	245	G11/4"	M8	ZYVP-100
ZYVP-175	870	540	590	505	320	455	310	G2"	M10	ZYVP-175
ZYVP-200	910	540	590	505	320	495	310	G2"	M10	ZYVP-200
ZYVP-250	990	540	590	505	320	560	310	G2"	M10	ZYVP-250
ZYVP-320	1050	560	640	545	315	565	310	G21/2"	M10	ZYVP-320
ZYVP-400	1120	560	640	545	315	595	310	G21/2"	M10	ZYVP-400
ZYVP-500	1150	590	640	545	340	620	350	G21/2"	M10	ZYVP-500
ZYVP-520	1520	865	985	905	465	810	505	G3"	M12	ZYVP-520
ZYVP-650	1690	865	985	905	465	945	505	G3"	M12	ZYVP-650
ZYVP-750	1170	920	985	905	525	1110	505	G4"	M16	ZYVP-750

Vakum & Basiç çevrim tabloları / Vacuum & Pressure Conversions

Units	mm H ₂ O	Torr(mm Hg)	micron	In. Hg.	In. H ₂ O	lb/in ² (psi)	mbar (hPa)	bar	Pa (N/m ²)	kPa	atm	kp/cm ² (at)
1 mbar (hPa)	10.197	0.75	750	2.953 x 10 ⁻²	0.402	1.45 x 10 ⁻²	1	1 x 10 ⁻²	100	0.1	9.869 x 10 ⁻⁴	1.02 x 10 ⁻¹
1 bar	1.02 x 10 ⁴	7.5 x 10 ²	7.5 x 10 ³	29.53	4.015 x 10 ²	14.5	103	1	1 x 10 ⁵	100	0.987	1.02
1 Pa (N/m ²)	0.102	7.5 x 10 ⁻¹	7.5	2.953 x 10 ⁻³	4.015 x 10 ⁻³	1.45 x 10 ⁻⁴	0.01	1 x 10 ⁻⁵	1	0.001	9.869 x 10 ⁻⁴	1.02 x 10 ⁻³
1 kPa	1.02 x 10 ³	7.5	7.5 x 10 ¹	0.295	4.015	0.145	10	0.01	1 x 10 ³	1	9.869 x 10 ⁻³	1.02 x 10 ⁻²
1 atm	1.033 x 10 ³	7.6 x 10 ²	7.6 x 10 ³	29.92	4.068 x 10 ²	14.7	1.013 x 10 ³	1.013	1.013 x 10 ⁵	1.013 x 10 ²	1	1.033
1 kp/cm ² (at)	1 x 10 ⁴	7.356 x 10 ²	7.356 x 10 ³	28.96	3.973 x 10 ²	14.22	9.807 x 10 ²	0.981	9.807 x 10 ⁴	98.07	0.968	1
1 mm H ₂ O	1	7.354 x 10 ⁻³	73.54	2.896 x 10 ⁻³	3.394 x 10 ⁻³	1.42 x 10 ⁻³	9.807 x 10 ⁻³	9.807 x 10 ⁻³	9.807	9.807 x 10 ⁻³	9.677 x 10 ⁻³	1 x 10 ⁻³
1 Torr (mm Hg)	13.59	1	1 x 10 ³	3.937 x 10 ⁻²	0.535	1.934 x 10 ⁻²	1.333	1.333 x 10 ³	1.333 x 10 ²	1.333 x 10 ¹	1.316 x 10 ⁻¹	1.36 x 10 ⁻¹
1 micron	1.359 x 10 ⁻³	1 x 10 ⁻³	1	3.937 x 10 ⁻³	5.35 x 10 ⁻⁴	1.934 x 10 ⁻⁵	1.333 x 10 ⁻³	1.333 x 10 ⁻³	1.333 x 10 ⁻¹	1.333 x 10 ⁻¹	1.316 x 10 ⁻⁴	1.36 x 10 ⁻⁴
1 in. Hg	3.45 x 10 ¹	25.4	2.54 x 10 ³	1	13.6	0.491	33.86	3.386 x 10 ⁻²	3.386 x 10 ³	3.386	3.342 x 10 ⁻²	3.453 x 10 ⁻¹
1 in. H ₂ O	25.4	1.868	1.868 x 10 ³	7.356 x 10 ⁻²	1	3.613 x 10 ⁻²	2.491	2.491 x 10 ⁻³	2.491 x 10 ²	0.249	2.458 x 10 ⁻³	2.54 x 10 ⁻¹
1 lb.in ² (psi)	7.03 x 10 ²	51.71	5.171 x 10 ⁴	2.036	27.68	1	68.95	6.895 x 10 ⁻²	6.895 x 10 ³	6.895	6.805 x 10 ⁻²	7.03 x 10 ⁻¹



DiĞER ÜRÜNLERİMİZ Other Products



Vakum Ambalaj Sistemleri : Elephant yatay hazneli - VPM dik hazneli vakum ambalaj makineleri - AGV (tabak ağız kapatma) ambalaj makineleri - otomatik termoform vakum ambalaj makineleri.

Vacuum Packing Systems : Elephant horizontal chamber - VPM vertical chamber vacuum packing machines - AGV Traysealers - Automatic thermoforming vacuum packing machines



Otomatik döner tablalı tabak kapatma makinası
Automatic rotary table tray sealer



Dikely vakum ambalaj makinesi (kuruyemiş, bakliyat, kahve vb. için)
Vertical vacuum packing machine (for dried fruits, grains, coffee etc.)

Elephant AGV tabak kapatma makinası
Elephant AGV traysealer



Vakum pompa yedek parça ve aksesuarları
Spare parts and accessories for vacuum pumps



DİĞER ÜRÜNLERİMİZ Other Products



Merkezi Vakum Üniteleri: Hastane ve diş poliklinikleri - Kompozit RTM ve infüzyon sistemleri - Plastik termofom ve vakum ambalaj sanayi - Ahşap ve empenye sanayi - Kimya sanayi için çok amaçlı santraller - Özel projeleri için üretim santralleri

Vakumlu Kaldırma Taşıma Sistemleri: Ağır hizmet tersane sac levha plazma kesim, kumlama ve boyama liftleri - Cam levha kesim ve cephe giydirme serisi liftler - Mermere ve doğal taş kaldırma, taşıma, yükleme, boşaltma sistemleri - Bataryalı uzaktan kumandalı liftler - Özel projelere uygun lift tasarımları

Central Vacuum Units: Hospitals and dental plants - Composite manufacturing systems, RTM & infusion applications - Thermofforming and vacuum packing systems - Woodworking and impregnation plants - Multipurpose vacuum plants for chemical and pharmaceutical industries - Custom vacuum plants for customer projects.

Vacuum Lifting & Transport Systems: Heavy duty sheet metal plasma cutting, sand blasting and painting lifts - Glass working lifts, outdoor panel assembly units - Marble and natural stone lifting, loading and unloading units - Battery operated remote control lifts - Customized vacuum lifters for specific products



Cam, cephe giydirme vakum taşıma sistemleri
Glass and aluminium panel assembly lifters



Endüstriyel vakumlu taşıma sistemleri
Heavy duty vacuum lifters & transport units

Çok amaçlı merkezi vakum sistemleri
Multi purpose central vacuum units



Bataryalı, forklift tipi vakumlu taşıma sistemleri
Battery operated, forklift mounted vacuum lifters



Kullanım alanları / Applications

Metalurji ve Kuyumculuk / Metallurgy

Vakum altında sertleştirme ve ısıtma işlemleri, ergitme, karbürizasyon, sinterleme uygulamaları değerli maden döküm ve kuyumculuk

Heat treatment, sintering, melting, carburization, hardening, tempering applications, precise casting for jewellery making.

Cam Sektörü / Glass Manufacturing

Cam levhaların taşınması, kesim ve rodaj makineleri, temperleme ve şekil verme uygulamaları, dış cephe montaj üniteleri.

Lifting and transporting glass sheets, edging and beveling machines, glass cutting automation, exterior assembling applications.

Kaplama Sistemleri / Coating Systems

Kesici takımların titanyum kaplama işlemleri, güneş panelleri, reflektör ve far üretimi, çeşitli ürünlerin metalizasyon uygulamaları

Anti-corrosion titanium coating for cutting tools, semi conductor devices, solar cells, reflector and headlight manufacturing, metallization applications

Vakumlu Taşıma / Vacuum Lifting

Sac levhaların kumlama, lazer ve plazma işlemleri, mermer ve doğal taş işleme, cam ve sandviç panel montaj uygulamaları, otomasyon sistemleri

Sandblasting, laser cutting and painting jobs of metal sheets, marble and natural stone processing, assembling glass sheets and sandwich panels.

Laboratuvar / Laboratory

Endüstriyel, medikal ve kurumsal laboratuvarlarda, kurutma, damıtma, gaz alma, ayırıştırma ve test uygulamalarında.

For industrial, medical and institutional laboratories, drying, distillation, degassing, separation and leak test applications.

Ahşap ve Mobilya / Woodworking

CNC Router tezgahlarında malzeme tutma, PVC membran kaplama, laminasyon, kurutma ve emprenye, vakumla kaldırma/taşıma üniteleri.

Fixing workpieces in CNC Routers, laminators, veneer presses, drying and impregnation kilns, vacuum lifting and conveying units for wood.

Medikal / Medical

Hastanelerin merkezi vakum sistemlerinde, ameliyathane, doğumhanelerde ve diş laboratuvarlarında.

Central vacuum units for hospitals, surgical operations, maternity rooms and dental laboratories.

Kompozit / Composites Manufacturing

Deniz, hava ve kara taşıt parçalarının infüzyon ve RTM yöntemi ile üretimi, dış cephe kaplamaları, çevre düzenleme ürünleri ve hediyelik eşya imalatı

Manufacturing components for air, naval and land vehicles with Infusion and RTM methods, exterior insulation panels, infrastructure products

Gıda Ambalaj/ Food Vacuum Packaging

Et mamülleri, süt ürünleri, deniz mahsulleri, bakliyat, kuruyemiş ve taze meyve sebzelerin vakum ambalajı, modifiye atmosfer uygulamaları

Vacuum packaging of meat & dairy products, seafood, grains, dried fruits, fresh vegetables, Modified Atmosphere Packing (MAP) applications

Kimya ve İlaç / Chemical & Pharmaceutical

Vakum altında homojen karıştırma, emprenye kurutma, reaksiyon tamamlama üniteleri, blister ambalajlama uygulamaları.

Mixing and impregnation processes under vacuum, drying chemical components, finalizing reactions, blister packing applications

Termoform / Thermoforming

Otomotiv ve uçak parçaları, akrilik küvet, açık hava reklamcılığı ürünleri, gıda kapları, oyuncak ve mobilya komponentleri üretimi.

Land and air vehicle components, acrylic bathtubs, outdoor advertising products, food containers, toy & furniture components.

Otomasyon / Automation

Vakumla kaldırma, taşıma, tutma üniteleri, kaynak, polisaj, boyama, yıkama ve ürün montaj uygulamaları, malzeme nakil sistemleri.

Vacuum lifting, transporting, holding units, surface treatment, welding, painting, washing & product assembly lines. Vacuum conveying systems.