

## SINGLE STAGE GEARBOXES SERIES S

### 67 DESIGN FEATURES

The main design characteristics are:

- modularity
- space effective
- high efficiency
- quite operation
- gears in hardened and case-hardened steel
- bare aluminium housing for sizes 10, 20, 30, unpainted high strength painted cast-iron housings for larger frame sizes
- input and output shafts from high grade steel.

(E 60)

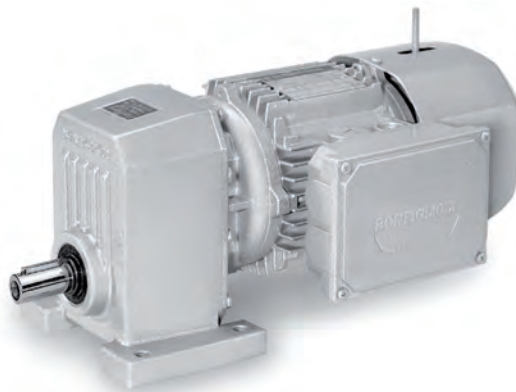
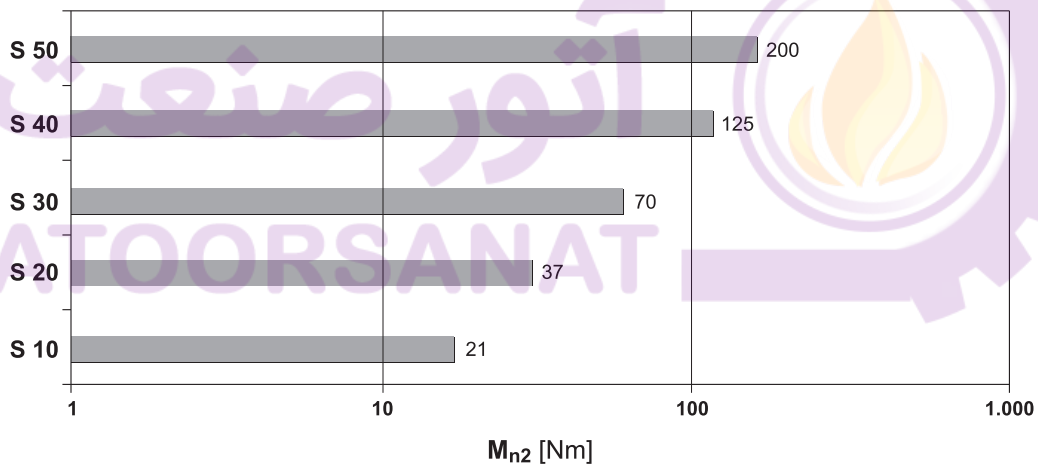

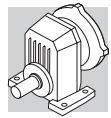

68 VERSIONS

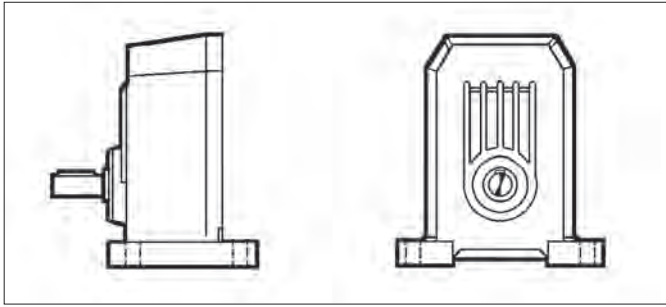

**P**

Foot mount

S 10 ... S 50

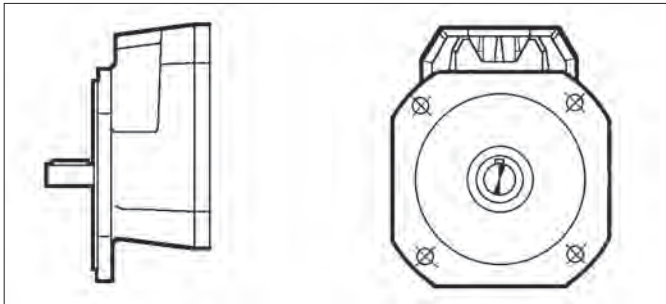

**F**

Flange mount

S 10 ... S 50

آتور صنعت  
ATOORSANAT

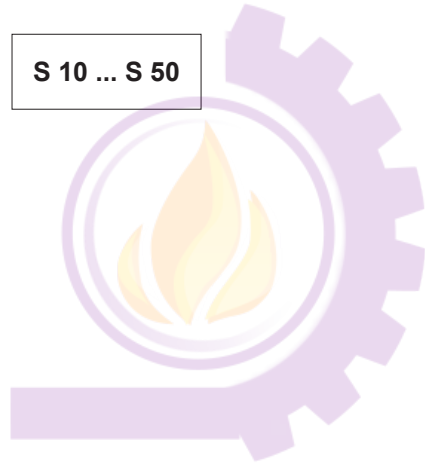

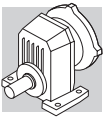

69 DESIGNATION

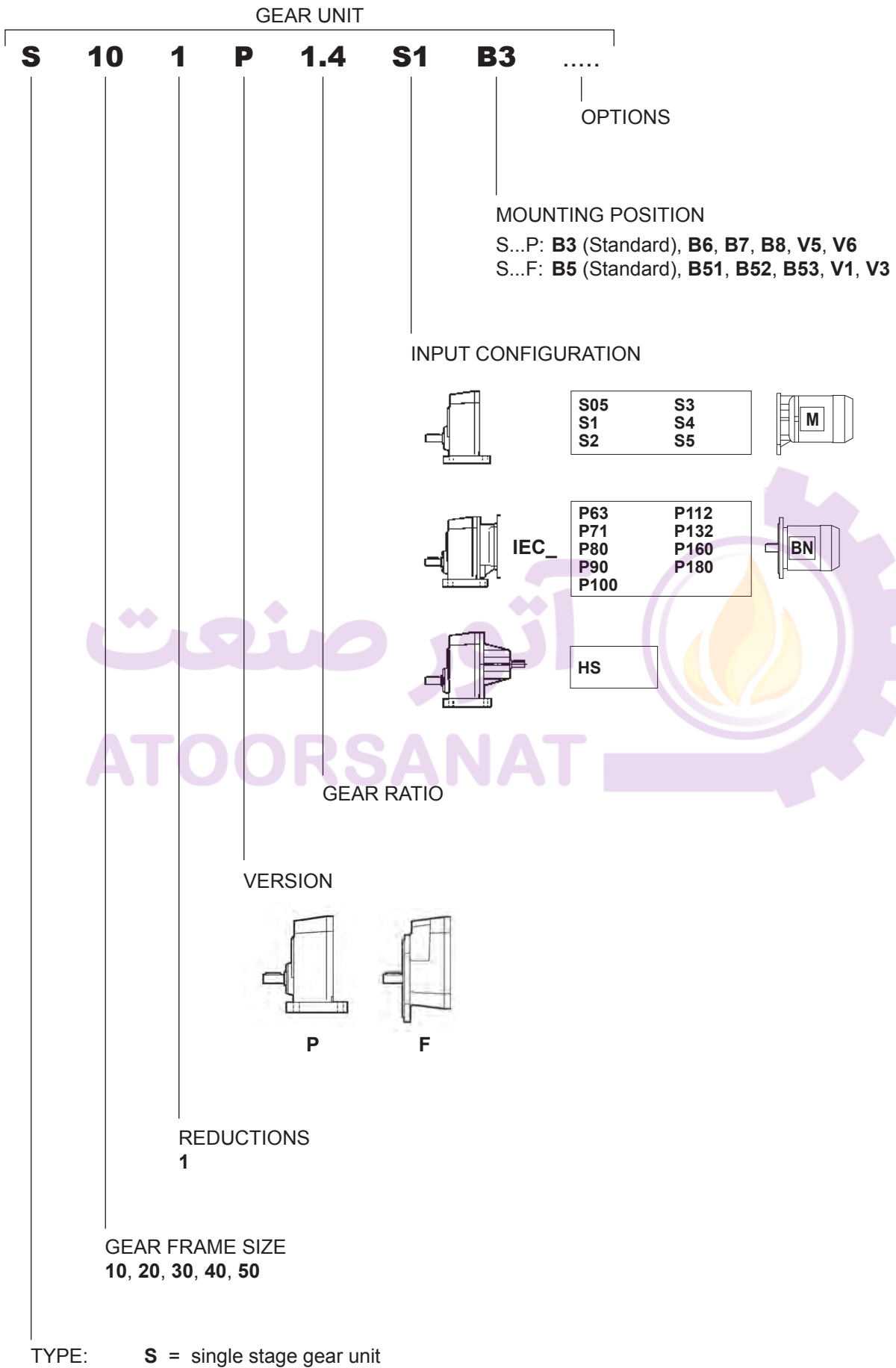

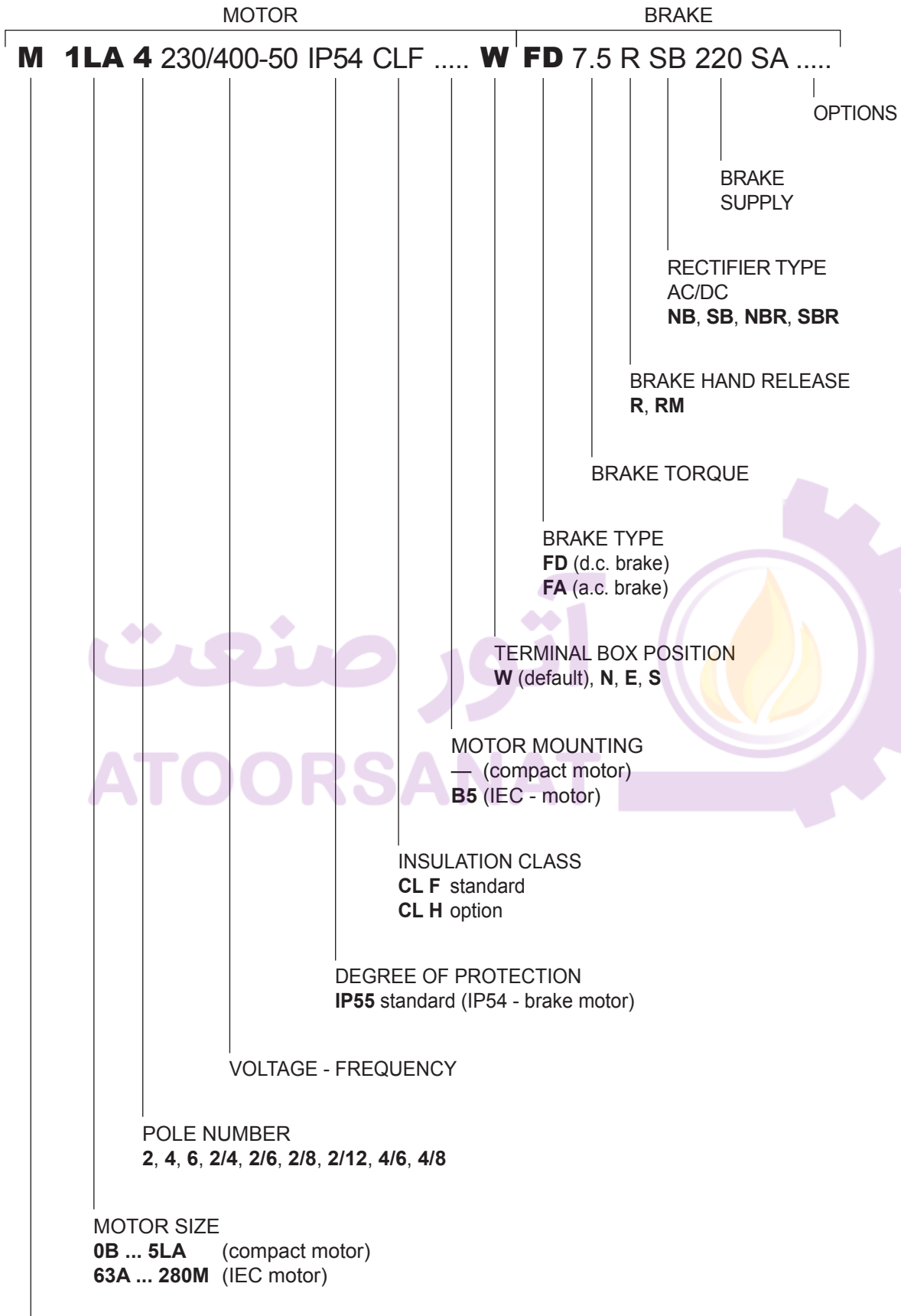

MOTOR TYPE  
**M** = compact 3-phase  
**BN** = IEC 3-phase

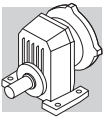

## 69.1 Gearbox options

### SO

Gear units S10, S20, S30, S40, usually factory filled with oil, to be supplied unlubricated.

### LO

Gearbox S50, usually supplied without oil, to be supplied with synthetic oil currently used by BONFIGLIOLI RIDUTTORI and filled according to requested mounting position.

### DV

Dual oil seals on input shaft. (Available only for compact gearmotors).

### VV

Fluoro elastomer oil seal on input shaft.

### PV

All oil seals in Fluoro elastomer.

## SURFACE PROTECTION

When no specific protection class is requested, the painted (ferrous) surfaces of gearboxes are protected to at least corrosivity class C2 (UNI EN ISO 12944-2). For improved resistance to atmospheric corrosion, gearboxes can be delivered with **C3** and **C4** surface protection, obtained by painting the complete gearbox.

(E 61)

SURFACE PROTECTION	Typical environments	Maximum surface temperature	Corrosivity class according to UNI EN ISO 12944-2
<b>C3</b>	Urban and industrial environments with up to 100% relative humidity (medium air pollution)	120°C	C3
<b>C4</b>	Industrial areas, coastal areas, chemical plant, with up to 100% relative humidity (high air pollution)	120°C	C4

Gearboxes with optional protection to class **C3** or **C4** are available in a choice of colours.

If no specific colour is requested (see the "PAINTING" option) gearboxes are finished in RAL 7042.

Gearboxes can also be supplied with surface protection for corrosivity class **C5** according to UNI EN ISO 12944-2. Contact our Technical Service for further details.

## PAINTING

Gearboxes with optional protection to class C3 or C4 are available in the colours listed in the following table.

(E 62)

PAINTING	Colour	RAL number
<b>RAL7042*</b>	Traffic Grey A	7042
<b>RAL5010</b>	Gentian Blue	5010
<b>RAL9005</b>	Jet Black	9005
<b>RAL9006</b>	White Aluminium	9006
<b>RAL9010</b>	Pure White	9010

\* Gearboxes are supplied in this standard colour if no other colour is specified.

NOTE – “PAINTING” options can only be specified in conjunction with “SURFACE PROTECTION” options.

## CERTIFICATES

### AC - Certificate of compliance

The document certifies the compliance of the product with the purchase order and the construction in conformity with the applicable procedures of the Bonfiglioli Quality System.

### CC - Inspection certificate

The document entails checking on order compliance, the visual inspection of external conditions and of mating dimensions. Checking on main functional parameters in unloaded conditions is also performed along with oil seal proofing, both in static and in running conditions. Units inspected are sampled within the shipping batch and marked individually.

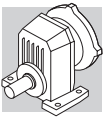

## 69.2 Motor options

### AL, AR

A backstop device on the motor itself, as described in the electric motors section of this catalogue, is available for gearmotors with integral M Series motors. The following table shows the direction of free rotation of the gearbox, on the basis of which the correct option must be selected.

(E 64)

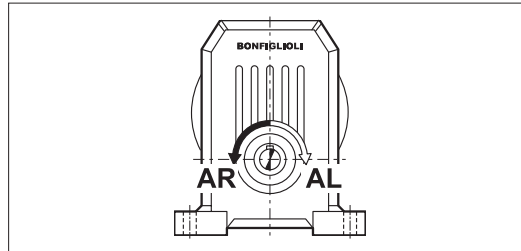

For further information on options, consult the electric motors section.

## 70 MOUNTING POSITION AND TERMINAL BOX ANGULAR LOCATION

Location of motor terminal box can be specified by viewing the motor from the fan side; standard location is shown in black (W).

### Angular position of the brake release lever.

Unless otherwise specified, brake motors have the manual device side located, 90° apart from terminal box.

Different angles can be specified through the relevant options available.

(E 63)

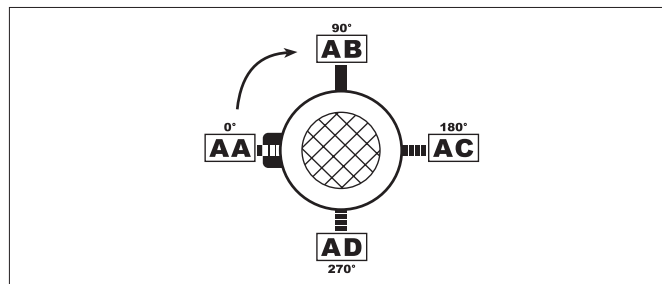

آتور صنعت  
ATOORSANAT

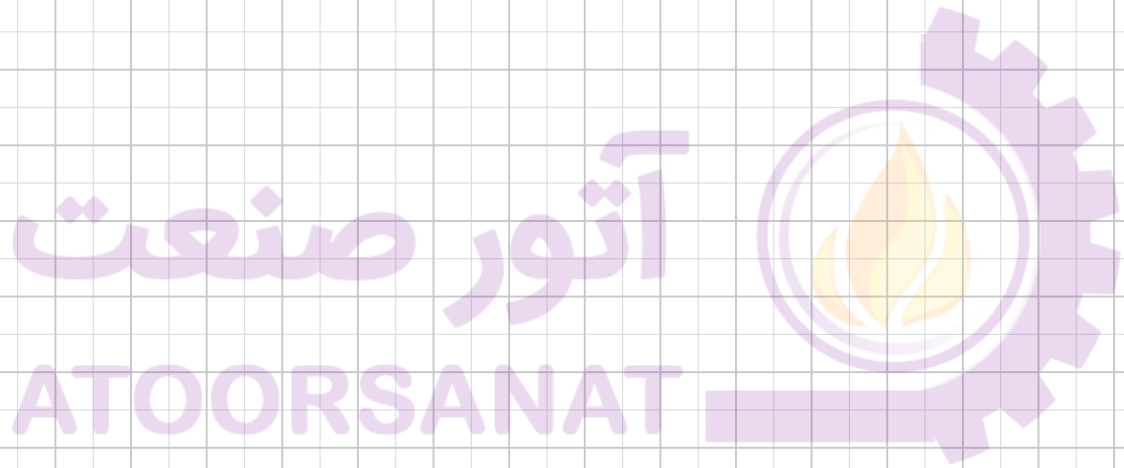



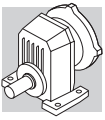

# S ... P

## B3

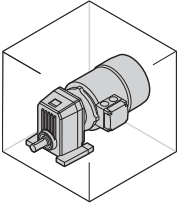

\_S

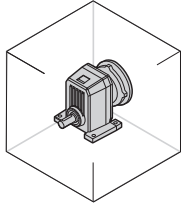

\_P(IEC)

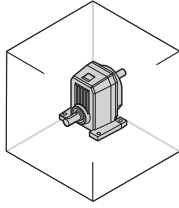

\_HS

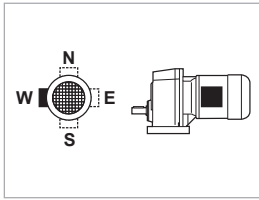

## B6

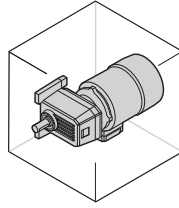

\_S

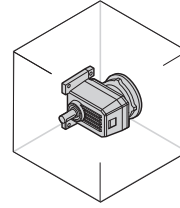

\_P(IEC)

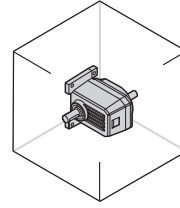

\_HS

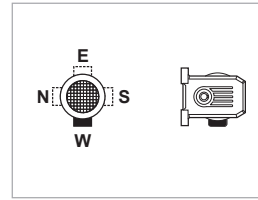

## B7

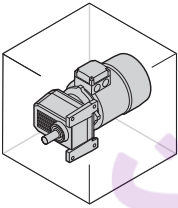

\_S

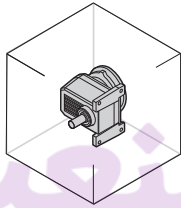

\_P(IEC)

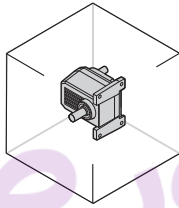

\_HS

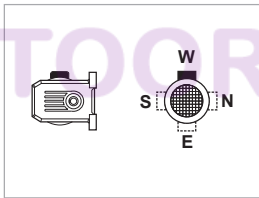

## B8

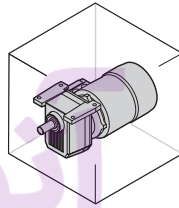

\_S

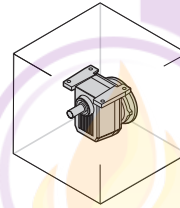

\_P(IEC)

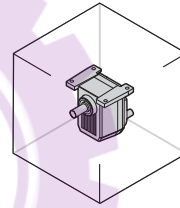

\_HS

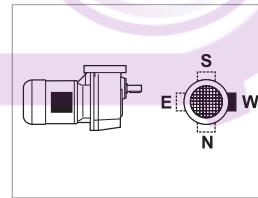

## V5

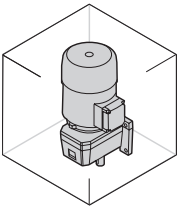

\_S

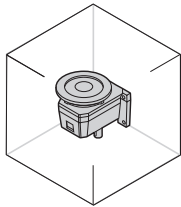

\_P(IEC)

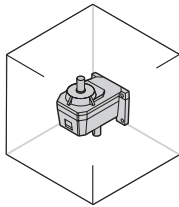

\_HS

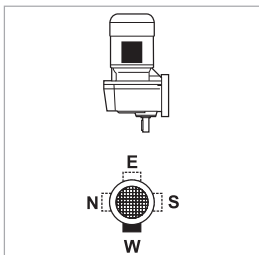

## V6

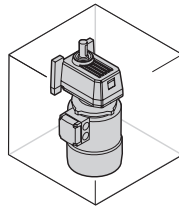

\_S

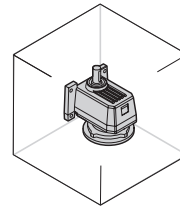

\_P(IEC)

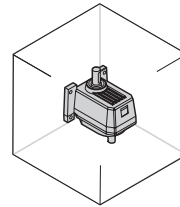

\_HS

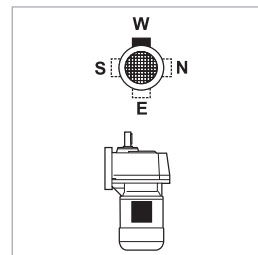

W = Default

# S ... F

## B5

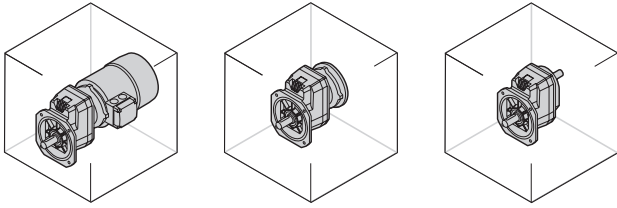

\_S

\_P(IEC)

\_HS

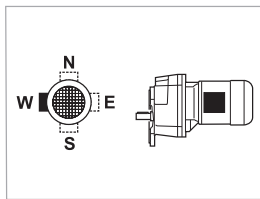

## B51

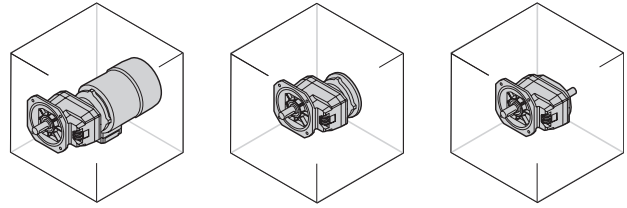

\_S

\_P(IEC)

\_HS

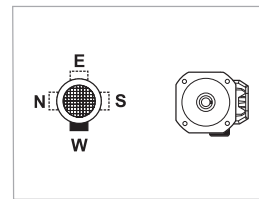

## B53

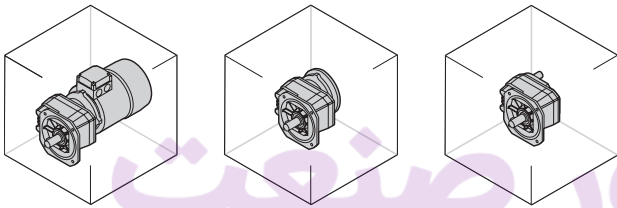

\_S

\_P(IEC)

\_HS

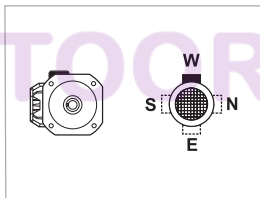

## B52

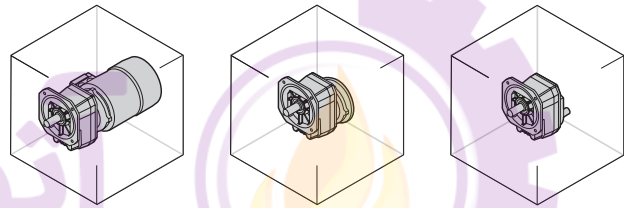

\_S

\_P(IEC)

\_HS

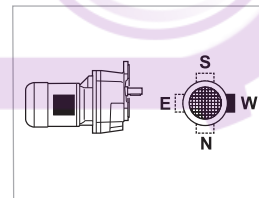

## V1

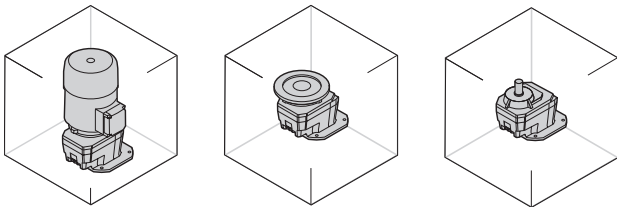

\_S

\_P(IEC)

\_HS

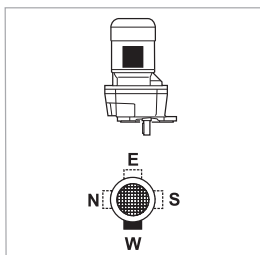

## V3

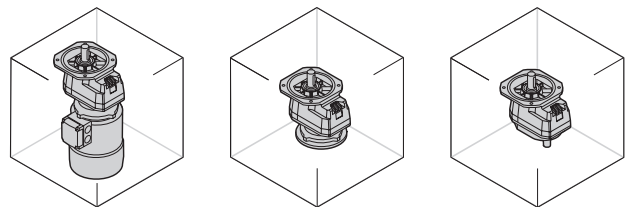

\_S

\_P(IEC)

\_HS

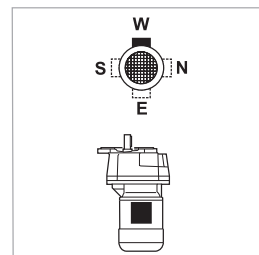

W = Default

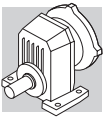

## 71 OVERHUNG LOADS

External transmissions keyed onto input and/or output shaft generate loads that act radially onto same shaft.

Resulting shaft loading must be compatible with both the bearing and the shaft capacity. Namely shaft loading ( $R_{c1}$  for input shaft,  $R_{c2}$  for output shaft), must be equal or lower than admissible overhung load capacity for shaft under study ( $R_{n1}$  for input shaft,  $R_{n2}$  for output shaft). OHL capability listed in the rating chart section.

In the formulas given below, index (1) applies to parameters relating to input shaft, whereas index (2) refers to output shaft.

The load generated by an external transmission can be calculated with close approximation by the following equations:

$$R_{c1} [N] = \frac{2000 \cdot M_1 [Nm] \cdot K_r}{d [mm]} \quad ; \quad R_{c2} [N] = \frac{2000 \cdot M_2 [Nm] \cdot K_r}{d [mm]} \quad (44)$$

(E 65)

$M_1$ [Nm]	Torque applied to input shaft	$K_r = 1,25$	Gear transmission
$M_2$ [Nm]	Torque drawn at output shaft	$K_r = 1,5$	V-belt transmission
$d$ [mm]	Pitch diameter of element keyed onto shaft	$K_r = 2,0$	Flat belt transmission
$K_r = 1$	Chain transmission		

Verification of OHL capability varies depending on whether load applies at midpoint of shaft or it is shifted further out:

(E 66)

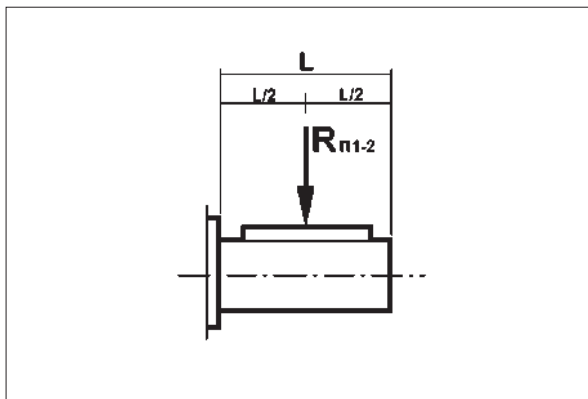

(E 67)

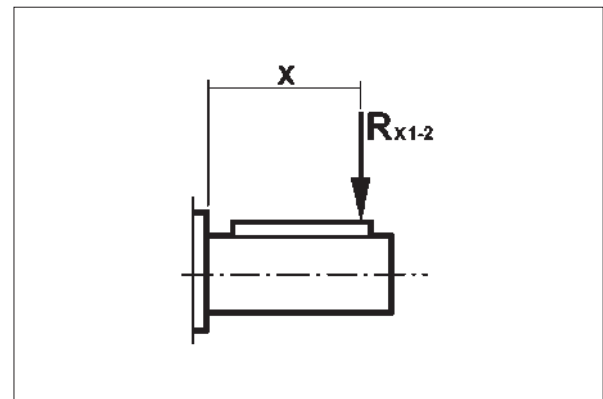

**a) Load applied at midpoint of shaft, tab. (E66)**

A comparison of shaft loading with catalogue OHL ratings should verify the following condition:

$$R_{c1} \leq R_{n1} \quad [\text{input shaft}]$$

or

$$R_{c2} \leq R_{n2} \quad [\text{output shaft}]$$

**b) Load off the midpoint tab. (E67)**

When load is shifted at an “x” distance from shaft shoulder, permissible load must be calculated for that distance.

Revised permissible overhung loads  $R_{x1}$  (input) and  $R_{x2}$  (output) are calculated respectively from original rated values  $R_{n1}$  and  $R_{n2}$  through factor:

$$\frac{a}{b+x} \quad (45)$$

(E 68)

	Load location factors					
	Output shaft			Input shaft		
	a	b	c	a	b	c
<b>S 10 1</b>	61	46	200	21	1	300
<b>S 20 1</b>	73.5	53.5	270	40	20	350
<b>S 30 1</b>	91.5	66.5	380	38.5	18.5	350
<b>S 40 1</b>	126.5	96.5	600	49.5	24.5	450
<b>S 50 1</b>	153.5	113.5	680	49.5	24.5	450

Verification procedure is described here after.

**INPUT SHAFT**

1. Calculate:

$$R_{x1} = R_{n1} \cdot \frac{a}{b+x} \quad (46)$$

N.B. Subject to condition:

$$\frac{L}{2} \leq x \leq c \quad (47)$$

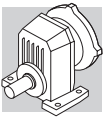

Finally, the following condition must be verified:

$$R_{c1} \leq R_{x1} \quad (48)$$

## OUTPUT SHAFT

1. Calculate:

$$R_{x2} = R_{n2} \cdot \frac{a}{b+x} \quad (49)$$

N.B. Subject to condition:

$$\frac{L}{2} \leq x \leq c \quad (50)$$

Finally, the following condition must be verified:

$$R_{c2} \leq R_{x2} \quad (51)$$

## 72 THRUST LOADS, $A_{n1}$ , $A_{n2}$

Permissible thrust loads on input [ $A_{n1}$ ] and output [ $A_{n2}$ ] shafts are obtained from the radial loading for the shaft under consideration [ $R_{n1}$ ] and [ $R_{n2}$ ] through the following equation:

$$\begin{aligned} A_{n1} &= R_{n1} \cdot 0.2 \\ A_{n2} &= R_{n2} \cdot 0.2 \end{aligned} \quad (52)$$





The thrust loads calculated through these formulas apply to thrust forces occurring at the same time as rated radial loads.

In the only case that no overhung load acts on the shaft the value of the admissible thrust load [ $A_n$ ] amounts to 50% of rated OHL [ $R_n$ ] on same shaft.



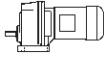

Where thrust loads exceed permissible value or largely prevail over radial loads, contact Bonfiglioli Riduttori for an in-depth analysis of the application.

73 GEARMOTOR RATING CHARTS

**0.09 kW**



n <sub>2</sub> min <sup>-1</sup>	M <sub>2</sub> Nm	S	i	R <sub>n2</sub> N				
69	12.1	2.9	13.1	2400			S301_13.1 P63 BN63A6	507
73	11.5	1.7	12.4	1500	S201_12.4 S05 M05A6	504	S201_12.4 P63 BN63A6	505
74	11.4	1.1	12.3	1160	S101_12.3 S05 M05A6	502	S101_12.3 P63 BN63A6	503
85	10.0	2.0	10.8	1500	S201_10.8 S05 M05A6	504	S201_10.8 P63 BN63A6	505
88	9.5	1.3	10.3	1100	S101_10.3 S05 M05A6	502	S101_10.3 P63 BN63A6	503
103	8.2	1.5	8.9	1060	S101_8.9 S05 M05A6	502	S101_8.9 P63 BN63A6	503
107	7.9	2.5	8.5	1500	S201_8.5 S05 M05A6	504	S201_8.5 P63 BN63A6	505
132	6.4	2.7	6.9	990	S101_6.9 S05 M05A6	502	S101_6.9 P63 BN63A6	503
149	5.7	3.0	6.1	960	S101_6.1 S05 M05A6	502	S101_6.1 P63 BN63A6	503
193	4.4	3.2	4.7	890	S101_4.7 S05 M05A6	502	S101_4.7 P63 BN63A6	503
237	3.6	3.9	3.8	830	S101_3.8 S05 M05A6	502	S101_3.8 P63 BN63A6	503
284	3.0	4.7	3.2	790	S101_3.2 S05 M05A6	502	S101_3.2 P63 BN63A6	503
364	2.3	5.2	2.5	730	S101_2.5 S05 M05A6	502	S101_2.5 P63 BN63A6	503
485	1.7	6.9	1.9	670	S101_1.9 S05 M05A6	502	S101_1.9 P63 BN63A6	503
640	1.3	9.1	1.4	610	S101_1.4 S05 M05A6	502	S101_1.4 P63 BN63A6	503

**0.12 kW**

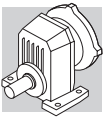

n <sub>2</sub> min <sup>-1</sup>	M <sub>2</sub> Nm	S	i	R <sub>n2</sub> N				
69	16.2	2.2	13.1	2400			S301_13.1 P63 BN63A4	507
73	15.3	1.3	12.4	1500	S201_12.4 S05 M05B6	504	S201_12.4 P63 BN63B6	505
85	13.3	1.5	10.8	1500	S201_10.8 S05 M05B6	504	S201_10.8 P63 BN63B6	505
88	12.7	2.8	10.3	2400			S301_10.3 P63 BN63B6	507
88	12.7	0.9	10.3	1060	S101_10.3 S05 M05B6	502	S101_10.3 P63 BN63B6	503
102	11.0	3.2	8.9	2400			S301_8.9 P63 BN63B6	507
103	11.0	1.1	8.9	1030	S101_8.9 S05 M05B6	502	S101_8.9 P63 BN63B6	503
107	10.5	2.8	13.1	2400			S301_13.1 P63 BN63B6	507
107	10.5	1.9	8.5	1500	S201_8.5 S05 M05B6	504	S201_8.5 P63 BN63B6	505
113	10.0	1.7	12.4	1500	S201_12.4 S05 M05A4	504	S201_12.4 P63 BN63A4	505
114	9.9	1.0	12.3	1000	S101_12.3 S05 M05A4	502	S101_12.3 P63 BN63A4	503
126	8.9	3.4	7.2	1500	S201_7.2 S05 M05B6	504	S201_7.2 P63 BN63B6	505
130	8.6	2.0	10.8	1500	S201_10.8 S05 M05A4	504	S201_10.8 P63 BN63A4	505
132	8.5	2.0	6.9	960	S101_6.9 S05 M05B6	502	S101_6.9 P63 BN63B6	503
136	8.3	1.2	10.3	960	S101_10.3 S05 M05A4	502	S101_10.3 P63 BN63A4	503
149	7.5	2.3	6.1	940	S101_6.1 S05 M05B6	502	S101_6.1 P63 BN63B6	503
158	7.1	1.4	8.9	920	S101_8.9 S05 M05A4	502	S101_8.9 P63 BN63A4	503
165	6.8	2.5	8.5	1500	S201_8.5 S05 M05A4	504	S201_8.5 P63 BN63A4	505
193	5.8	2.4	4.7	870	S101_4.7 S05 M05B6	502	S101_4.7 P63 BN63B6	503
203	5.5	2.7	6.9	860	S101_6.9 S05 M05A4	502	S101_6.9 P63 BN63A4	503
229	4.9	3.1	6.1	830	S101_6.1 S05 M05A4	502	S101_6.1 P63 BN63A4	503
237	4.7	2.9	3.8	820	S101_3.8 S05 M05B6	502	S101_3.8 P63 BN63B6	503
284	3.9	3.5	3.2	780	S101_3.2 S05 M05B6	502	S101_3.2 P63 BN63B6	503
296	3.8	3.2	4.7	770	S101_4.7 S05 M05A4	502	S101_4.7 P63 BN63A4	503
364	3.1	3.9	3.8	720	S101_3.8 S05 M05A4	502	S101_3.8 P63 BN63A4	503
364	3.1	3.9	2.5	720	S101_2.5 S05 M05B6	502	S101_2.5 P63 BN63B6	503
438	2.6	4.7	3.2	680	S101_3.2 S05 M05A4	502	S101_3.2 P63 BN63A4	503

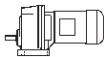



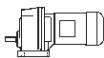

## 0.12 kW

n <sub>2</sub> min <sup>-1</sup>	M <sub>2</sub> Nm	S	i	R <sub>n2</sub> N				
485	2.3	5.2	1.9	660	S101_1.9 S05 M05B6	502	S101_1.9 P63 BN63B6	503
560	2.0	5.0	2.5	630	S101_2.5 S05 M05A4	502	S101_2.5 P63 BN63A4	503
640	1.8	6.8	1.4	600	S101_1.4 S05 M05B6	502	S101_1.4 P63 BN63B6	503
747	1.5	6.6	1.9	580	S101_1.9 S05 M05A4	502	S101_1.9 P63 BN63A4	503
985	1.1	8.8	1.4	530	S101_1.4 S05 M05A4	502	S101_1.4 P63 BN63A4	503



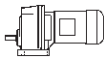

## 0.18 kW

n <sub>2</sub> min <sup>-1</sup>	M <sub>2</sub> Nm	S	i	R <sub>n2</sub> N				
69	24.6	1.4	13.1	2400			S301_13.1 P71 BN71A6	507
73	23.2	2.5	12.4	3800	S401_12.4 S1 M1SC6	508	S401_12.4 P71 BN71A6	500
84	20.1	1.0	10.8	1500			S201_10.8 P71 BN71A6	505
84	20.0	2.9	10.7	3800	S401_10.7 S1 M1SC6	508	S401_10.7 P71 BN71A6	500
87	19.3	1.8	10.3	2400	S301_10.3 S1 M1SC6	506	S301_10.3 P71 BN71A6	507
101	16.6	2.1	8.9	2400	S301_8.9 S1 M1SC6	506	S301_8.9 P71 BN71A6	507
106	15.9	1.3	8.5	1500	S201_8.5 S1 M1SC6	504	S201_8.5 P71 BN71A6	505
106	15.9	1.9	13.1	2400			S301_13.1 P63 BN63B4	507
112	15.1	1.1	12.4	1500	S201_12.4 S05 M05B4	504	S201_12.4 P63 BN63B4	505
112	15.0	3.3	12.4	3800			S401_12.4 P63 BN63B4	509
125	13.5	2.2	7.2	1500	S201_7.2 S1 M1SC6	504	S201_7.2 P71 BN71A6	505
129	13.0	1.3	10.8	1500	S201_10.8 S05 M05B4	504	S201_10.8 P63 BN63B4	505
130	12.9	1.3	6.9	910	S101_6.9 S1 M1SC6	502	S101_6.9 P71 BN71A6	503
135	12.5	2.4	10.3	2330			S301_10.3 P63 BN63B4	507
147	11.4	1.5	6.1	890	S101_6.1 S1 M1SC6	502	S101_6.1 P71 BN71A6	503
155	10.9	2.8	5.8	1500	S201_5.8 S1 M1SC6	504	S201_5.8 P71 BN71A6	505
156	10.8	2.8	8.9	2230			S301_8.9 P63 BN63B4	507
157	10.8	0.9	8.9	880	S101_8.9 S05 M05B4	502	S101_8.9 P63 BN63B4	503
164	10.3	1.7	8.5	1500	S201_8.5 S05 M05B4	504	S201_8.5 P63 BN63B4	505
189	8.9	3.4	4.8	1500	S201_4.8 S1 M1SC6	504	S201_4.8 P71 BN71A6	505
190	8.8	1.6	4.7	830	S101_4.7 S1 M1SC6	502	S101_4.7 P71 BN71A6	503
192	8.8	3.0	7.2	1500	S201_7.2 S05 M05B4	504	S201_7.2 P63 BN63B4	505
201	8.4	1.8	6.9	820	S101_6.9 S05 M05B4	502	S101_6.9 P63 BN63B4	503
214	7.9	3.1	13.1	2020			S301_13.1 P63 BN63A2	507
226	7.5	1.7	12.4	1480	S201_12.4 S05 M05A2	504	S201_12.4 P63 BN63A2	505
227	7.4	2.0	6.1	800	S101_6.1 S05 M05B4	502	S101_6.1 P63 BN63B4	503
228	7.4	1.1	12.3	800	S101_12.3 S05 M05A2	502	S101_12.3 P63 BN63A2	503
234	7.2	1.9	3.8	790	S101_3.8 S1 M1SC6	502	S101_3.8 P71 BN71A6	503
261	6.4	2.0	10.8	1420	S201_10.8 S05 M05A2	504	S201_10.8 P63 BN63A2	505
273	6.2	1.3	10.3	760	S101_10.3 S05 M05A2	502	S101_10.3 P63 BN63A2	503
281	6.0	2.3	3.2	750	S101_3.2 S1 M1SC6	502	S101_3.2 P71 BN71A6	503
294	5.7	2.1	4.7	750	S101_4.7 S05 M05B4	502	S101_4.7 P63 BN63B4	503
317	5.3	1.5	8.9	730	S101_8.9 S05 M05A2	502	S101_8.9 P63 BN63A2	503
331	5.1	2.6	8.5	1320	S201_8.5 S05 M05A2	504	S201_8.5 P63 BN63A2	505
360	4.7	2.6	2.5	700	S101_2.5 S1 M1SC6	502	S101_2.5 P71 BN71A6	503
361	4.7	2.6	3.8	700	S101_3.8 S05 M05B4	502	S101_3.8 P63 BN63B4	503
407	4.1	2.9	6.9	680	S101_6.9 S05 M05A2	502	S101_6.9 P63 BN63A2	503
434	3.9	3.1	3.2	670	S101_3.2 S05 M05B4	502	S101_3.2 P63 BN63B4	503
460	3.7	3.3	6.1	660	S101_6.1 S05 M05A2	502	S101_6.1 P63 BN63A2	503

## 0.18 kW

n <sub>2</sub> min <sup>-1</sup>	M <sub>2</sub> Nm	S	i	R <sub>n2</sub> N				
480	3.5	3.4	1.9	640	S101_1.9 S1 M1SC6	502	S101_1.9 P71 BN71A6	503
556	3.0	3.3	2.5	620	S101_2.5 S05 M05B4	502	S101_2.5 P63 BN63B4	503
594	2.8	3.5	4.7	610	S101_4.7 S05 M05A2	502	S101_4.7 P63 BN63A2	503
633	2.7	4.5	1.4	590	S101_1.4 S1 M1SC6	502	S101_1.4 P71 BN71A6	503
731	2.3	4.3	3.8	570	S101_3.8 S05 M05A2	502	S101_3.8 P63 BN63A2	503
741	2.3	4.4	1.9	570	S101_1.9 S05 M05B4	502	S101_1.9 P63 BN63B4	503
878	1.9	5.2	3.2	540	S101_3.2 S05 M05A2	502	S101_3.2 P63 BN63A2	503
978	1.7	5.8	1.4	520	S101_1.4 S05 M05B4	502	S101_1.4 P63 BN63B4	503
1124	1.5	5.3	2.5	500	S101_2.5 S05 M05A2	502	S101_2.5 P63 BN63A2	503
1499	1.1	7.1	1.9	460	S101_1.9 S05 M05A2	502	S101_1.9 P63 BN63A2	503
1977	0.9	9.4	1.4	420	S101_1.4 S05 M05A2	502	S101_1.4 P63 BN63A2	503



## 0.25 kW

n <sub>2</sub> min <sup>-1</sup>	M <sub>2</sub> Nm	S	i	R <sub>n2</sub> N				
69	34.1	1.0	13.1	2400			S301_13.1 P71 BN71B6	507
70	33.5	3.0	12.9	6520	S501_12.9 S1 M1SD6	510	S501_12.9 P71 BN71B6	511
73	32.2	1.8	12.4	3800	S401_12.4 S1 M1SD6	508	S401_12.4 P71 BN71B6	509
84	27.7	2.1	10.7	3800	S401_10.7 S1 M1SD6	508	S401_10.7 P71 BN71B6	509
87	26.8	1.3	10.3	2400	S301_10.3 S1 M1SD6	506	S301_10.3 P71 BN71B6	507
101	23.1	1.5	8.9	2400	S301_8.9 S1 M1SD6	506	S301_8.9 P71 BN71B6	507
104	22.5	3.1	8.6	3800	S401_8.6 S1 M1SD6	508	S401_8.6 P71 BN71B6	509
105	22.3	1.3	13.1	2400			S301_13.1 P71 BN71A4	507
106	22.1	0.9	8.5	1500	S201_8.5 S1 M1SD6	504	S201_8.5 P71 BN71B6	505
111	21.1	2.4	12.4	3800			S401_12.4 P71 BN71A4	509
125	18.8	1.6	7.2	1500	S201_7.2 S1 M1SD6	504	S201_7.2 P71 BN71B6	505
127	18.4	3.1	7.1	2340	S301_7.1 S1 M1SD6	506	S301_7.1 P71 BN71B6	507
128	18.3	0.9	10.8	1500	S201_10.8 S05 M05C4	504	S201_10.8 P71 BN71A4	505
129	18.2	2.8	10.7	3800			S401_10.7 P71 BN71A4	509
130	17.9	0.9	6.9	850	S101_6.9 S1 M1SD6	502	S101_6.9 P71 BN71B6	503
133	17.5	1.7	10.3	2300			S301_10.3 P71 BN71A4	507
147	15.9	1.1	6.1	840	S101_6.1 S1 M1SD6	502	S101_6.1 P71 BN71B6	503
155	15.1	2.0	5.8	1500	S201_5.8 S1 M1SD6	504	S201_5.8 P71 BN71B6	505
155	15.1	2.0	8.9	2200			S301_8.9 P71 BN71A4	507
162	14.5	1.2	8.5	1500	S201_8.5 S05 M05C4	504	S201_8.5 P71 BN71A4	505
189	12.4	2.4	4.8	1500	S201_4.8 S1 M1SD6	504	S201_4.8 P71 BN71B6	505
190	12.3	1.1	4.7	790	S101_4.7 S1 M1SD6	502	S101_4.7 P71 BN71B6	503
190	12.3	2.1	7.2	1500	S201_7.2 S05 M05C4	504	S201_7.2 P71 BN71A4	505
199	11.7	1.3	6.9	780	S101_6.9 S05 M05C4	502	S101_6.9 P71 BN71A4	503
214	10.9	2.2	13.1	2000			S301_13.1 P63 BN63B2	507
225	10.4	1.4	6.1	770	S101_6.1 S05 M05C4	502	S101_6.1 P71 BN71A4	503
226	10.3	1.3	12.4	1450	S201_12.4 S05 M05B2	504	S201_12.4 P63 BN63B2	505
229	10.2	2.9	3.9	1440	S201_3.9 S1 M1SD6	504	S201_3.9 P71 BN71B6	505
234	10.0	1.4	3.8	750	S101_3.8 S1 M1SD6	502	S101_3.8 P71 BN71B6	503
236	9.9	2.6	5.8	1430	S201_5.8 S05 M05C4	504	S201_5.8 P71 BN71A4	505
261	9.0	1.5	10.8	1390	S201_10.8 S05 M05B2	504	S201_10.8 P63 BN63B2	505
273	8.6	2.8	10.3	1860			S301_10.3 P63 BN63B2	507
273	8.6	0.9	10.3	730	S101_10.3 S05 M05B2	502	S101_10.3 P63 BN63B2	503

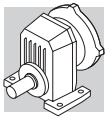



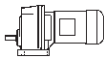

## 0.25 kW



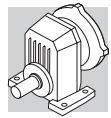

n <sub>2</sub> min <sup>-1</sup>	M <sub>2</sub> Nm	S	i	R <sub>n2</sub> N				
281	8.3	1.7	3.2	720	S101_3.2 S1 M1SD6	502	S101_3.2 P71 BN71B6	503
288	8.1	3.2	4.8	1350	S201_4.8 S05 M05C4	504	S201_4.8 P71 BN71A4	505
291	8.0	1.5	4.7	720	S101_4.7 S05 M05C4	502	S101_4.7 P71 BN71A4	503
316	7.4	3.2	8.9	1770			S301_8.9 P63 BN63B2	507
317	7.4	1.1	8.9	710	S101_8.9 S05 M05B2	502	S101_8.9 P63 BN63B2	503
331	7.1	1.8	8.5	1300	S201_8.5 S05 M05B2	504	S201_8.5 P63 BN63B2	505
358	6.5	1.8	3.8	680	S101_3.8 S05 M05C4	502	S101_3.8 P71 BN71A4	503
360	6.5	1.8	2.5	680	S101_2.5 S1 M1SD6	502	S101_2.5 P71 BN71B6	503
389	6.0	3.5	7.2	1240	S201_7.2 S05 M05B2	504	S201_7.2 P63 BN63B2	505
407	5.7	2.1	6.9	660	S101_6.9 S05 M05B2	502	S101_6.9 P63 BN63B2	503
430	5.4	2.2	3.2	650	S101_3.2 S05 M05C4	502	S101_3.2 P71 BN71A4	503
460	5.1	2.4	6.1	640	S101_6.1 S05 M05B2	502	S101_6.1 P63 BN63B2	503
480	4.9	2.5	1.9	620	S101_1.9 S1 M1SD6	502	S101_1.9 P71 BN71B6	503
550	4.3	2.4	2.5	610	S101_2.5 S05 M05C4	502	S101_2.5 P71 BN71A4	503
594	3.9	2.5	4.7	600	S101_4.7 S05 M05B2	502	S101_4.7 P63 BN63B2	503
633	3.7	3.2	1.4	580	S101_1.4 S1 M1SD6	502	S101_1.4 P71 BN71B6	503
731	3.2	3.1	3.8	560	S101_3.8 S05 M05B2	502	S101_3.8 P63 BN63B2	503
733	3.2	3.1	1.9	560	S101_1.9 S05 M05C4	502	S101_1.9 P71 BN71A4	503
878	2.7	3.8	3.2	530	S101_3.2 S05 M05B2	502	S101_3.2 P63 BN63B2	503
968	2.4	4.1	1.4	510	S101_1.4 S05 M05C4	502	S101_1.4 P71 BN71A4	503
1124	2.1	3.8	2.5	500	S101_2.5 S05 M05B2	502	S101_2.5 P63 BN63B2	503
1499	1.6	5.1	1.9	450	S101_1.9 S05 M05B2	502	S101_1.9 P63 BN63B2	503
1977	1.2	6.8	1.4	420	S101_1.4 S05 M05B2	502	S101_1.4 P63 BN63B2	503

## 0.37 kW



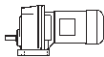

n <sub>2</sub> min <sup>-1</sup>	M <sub>2</sub> Nm	S	i	R <sub>n2</sub> N				
71	49.0	2.0	12.9	6420	S501_12.9 S1 M1LA6	510	S501_12.9 P80 BN80A6	511
73	47.2	1.2	12.4	3800	S401_12.4 S1 M1LA6	508	S401_12.4 P80 BN80A6	509
85	40.6	1.4	10.7	3800	S401_10.7 S1 M1LA6	508	S401_10.7 P80 BN80A6	509
87	39.8	2.9	10.5	6020	S501_10.5 S1 M1LA6	510	S501_10.5 P80 BN80A6	511
102	33.8	1.0	8.9	2400	S301_8.9 S1 M1LA6	506	S301_8.9 P80 BN80A6	507
104	33.2	0.9	13.1	2390			S301_13.1 P71 BN71B4	507
105	32.9	2.1	8.6	3800	S401_8.6 S1 M1LA6	508	S401_8.6 P80 BN80A6	509
106	32.6	3.1	12.9	5650	S501_12.9 S1 M1SD4	510	S501_12.9 P71 BN71B4	511
110	31.3	1.6	12.4	3800	S401_12.4 S1 M1SD4	508	S401_12.4 P71 BN71B4	509
126	27.5	1.1	7.2	1500	S201_7.2 S1 M1LA6	504	S201_7.2 P80 BN80A6	505
127	27.2	3.3	7.2	3800	S401_7.2 S1 M1LA6	508	S401_7.2 P80 BN80A6	509
128	27.0	2.1	7.1	2260	S301_7.1 S1 M1LA6	506	S301_7.1 P80 BN80A6	507
128	27.0	1.9	10.7	3800	S401_10.7 S1 M1SD4	508	S401_10.7 P71 BN71B4	509
133	26.0	1.2	10.3	2240	S301_10.3 S1 M1SD4	506	S301_10.3 P71 BN71B4	507
154	22.5	1.3	8.9	2150	S301_8.9 S1 M1SD4	506	S301_8.9 P71 BN71B4	507
156	22.2	2.6	5.8	2140	S301_5.8 S1 M1LA6	506	S301_5.8 P80 BN80A6	507
156	22.1	1.4	5.8	1500	S201_5.8 S1 M1LA6	504	S201_5.8 P80 BN80A6	505
159	21.8	2.7	8.6	3610	S401_8.6 S1 M1SD4	508	S401_8.6 P71 BN71B4	509
184	18.8	3.1	4.9	2040	S301_4.9 S1 M1LA6	506	S301_4.9 P80 BN80A6	507
190	18.3	1.4	7.2	1460	S201_7.2 S1 M1SD4	504	S201_7.2 P71 BN71B4	505
191	18.1	1.7	4.8	1460	S201_4.8 S1 M1LA6	504	S201_4.8 P80 BN80A6	505



## 0.37 kW



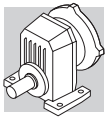

n <sub>2</sub> min <sup>-1</sup>	M <sub>2</sub> Nm	S	i	R <sub>n2</sub> N				
193	17.9	2.8	7.1	2020	S301_7.1 S1 M1SD4	506	S301_7.1 P71 BN71B4	507
214	16.2	1.5	13.1	1960			S301_13.1 P71 BN71A2	507
224	15.4	1.0	6.1	710	S101_6.1 S1 M1SD4	502	S101_6.1 P71 BN71B4	503
227	15.3	2.6	12.4	3230			S401_12.4 P71 BN71A2	509
231	15.0	2.0	3.9	1380	S201_3.9 S1 M1LA6	504	S201_3.9 P80 BN80A6	505
234	14.8	3.4	5.8	1900	S301_5.8 S1 M1SD4	506	S301_5.8 P71 BN71B4	507
235	14.7	1.8	5.8	1390	S201_5.8 S1 M1SD4	504	S201_5.8 P71 BN71B4	505
237	14.6	1.0	3.8	690	S101_3.8 S1 M1LA6	502	S101_3.8 P80 BN80A6	503
261	13.2	1.0	10.8	1350	S201_10.8 S05 M05C2	504	S201_10.8 P71 BN71A2	505
263	13.1	3.0	10.7	3080			S401_10.7 P71 BN71A2	509
273	12.7	1.9	10.3	1820			S301_10.3 P71 BN71A2	507
284	12.2	1.1	3.2	670	S101_3.2 S1 M1LA6	502	S101_3.2 P80 BN80A6	503
287	12.1	2.2	4.8	1310	S201_4.8 S1 M1SD4	504	S201_4.8 P71 BN71B4	505
290	11.9	1.0	4.7	670	S101_4.7 S1 M1SD4	502	S101_4.7 P71 BN71B4	503
293	11.8	2.5	3.1	1300	S201_3.1 S1 M1LA6	504	S201_3.1 P80 BN80A6	505
316	11.0	2.2	8.9	1740			S301_8.9 P71 BN71A2	507
331	10.5	1.2	8.5	1270	S201_8.5 S05 M05C2	504	S201_8.5 P71 BN71A2	505
348	9.9	2.6	3.9	1240	S201_3.9 S1 M1SD4	504	S201_3.9 P71 BN71B4	505
356	9.7	1.2	3.8	640	S101_3.8 S1 M1SD4	502	S101_3.8 P71 BN71B4	503
364	9.5	1.3	2.5	630	S101_2.5 S1 M1LA6	502	S101_2.5 P80 BN80A6	503
373	9.3	3.2	2.4	1210	S201_2.4 S1 M1LA6	504	S201_2.4 P80 BN80A6	505
389	8.9	2.4	7.2	1210	S201_7.2 S05 M05C2	504	S201_7.2 P71 BN71A2	505
407	8.5	1.4	6.9	630	S101_6.9 S05 M05C2	502	S101_6.9 P71 BN71A2	503
428	8.1	1.5	3.2	620	S101_3.2 S1 M1SD4	502	S101_3.2 P71 BN71B4	503
440	7.9	3.3	3.1	1160	S201_3.1 S1 M1SD4	504	S201_3.1 P71 BN71B4	505
460	7.5	1.6	6.1	610	S101_6.1 S05 M05C2	502	S101_6.1 P71 BN71A2	503
480	7.2	2.8	1.9	1130	S201_1.9 S1 M1LA6	504	S201_1.9 P80 BN80A6	505
483	7.2	2.9	5.8	1130	S201_5.8 S05 M05C2	504	S201_5.8 P71 BN71A2	505
485	7.1	1.7	1.9	590	S101_1.9 S1 M1LA6	502	S101_1.9 P80 BN80A6	503
548	6.3	1.6	2.5	580	S101_2.5 S1 M1SD4	502	S101_2.5 P71 BN71B4	503
594	5.8	1.7	4.7	570	S101_4.7 S05 M05C2	502	S101_4.7 P71 BN71A2	503
640	5.4	2.2	1.4	550	S101_1.4 S1 M1LA6	502	S101_1.4 P80 BN80A6	503
731	4.7	2.1	3.8	540	S101_3.8 S05 M05C2	502	S101_3.8 P71 BN71A2	503
731	4.7	2.1	1.9	540	S101_1.9 S1 M1SD4	502	S101_1.9 P71 BN71B4	503
878	3.9	2.5	3.2	520	S101_3.2 S05 M05C2	502	S101_3.2 P71 BN71A2	503
964	3.6	2.8	1.4	500	S101_1.4 S1 M1SD4	502	S101_1.4 P71 BN71B4	503
1124	3.1	2.6	2.5	480	S101_2.5 S05 M05C2	502	S101_2.5 P71 BN71A2	503
1499	2.3	3.5	1.9	440	S101_1.9 S05 M05C2	502	S101_1.9 P71 BN71A2	503
1977	1.8	4.6	1.4	410	S101_1.4 S05 M05C2	502	S101_1.4 P71 BN71A2	503

## 0.55 kW

n <sub>2</sub> min <sup>-1</sup>	M <sub>2</sub> Nm	S	i	R <sub>n2</sub> N				
71	72.1	1.4	12.9	6290	S501_12.9 S2 M2SA6	510	S501_12.9 P80 BN80B6	511
86	59.7	1.0	10.7	3800	S401_10.7 S2 M2SA6	508	S401_10.7 P80 BN80B6	509
88	58.5	2.0	10.5	5910	S501_10.5 S2 M2SA6	510	S501_10.5 P80 BN80B6	511
105	49.1	2.5	8.8	5600	S501_8.8 S2 M2SA6	510	S501_8.8 P80 BN80B6	511
107	48.3	1.4	8.6	3800	S401_8.6 S2 M2SA6	508	S401_8.6 P80 BN80B6	509

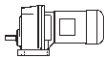



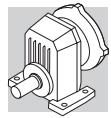

## 0.55 kW



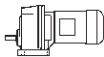

n <sub>2</sub> min <sup>-1</sup>	M <sub>2</sub> Nm	S	i	R <sub>n2</sub> N				
107	48.1	2.1	12.9	5560	S501_12.9 S1 M1LA4	510	S501_12.9 P80 BN80A4	511
111	46.3	1.1	12.4	3800	S401_12.4 S1 M1LA4	508	S401_12.4 P80 BN80A4	509
124	41.4	3.4	7.4	5310	S501_7.4 S2 M2SA6	510	S501_7.4 P80 BN80B6	511
129	40.0	2.2	7.2	3780	S401_7.2 S2 M2SA6	508	S401_7.2 P80 BN80B6	509
129	39.8	1.3	10.7	3770	S401_10.7 S1 M1LA4	508	S401_10.7 P80 BN80A4	509
130	39.7	1.5	7.1	2150	S301_7.1 S2 M2SA6	506	S301_7.1 P80 BN80B6	507
132	39.0	2.8	10.5	5220	S501_10.5 S1 M1LA4	510	S501_10.5 P80 BN80A4	511
152	33.9	3.1	6.1	3600	S401_6.1 S2 M2SA6	508	S401_6.1 P80 BN80B6	509
155	33.2	0.9	8.9	2060	S301_8.9 S1 M1LA4	506	S301_8.9 P80 BN80A4	507
157	32.7	1.8	5.8	2050	S301_5.8 S2 M2SA6	506	S301_5.8 P80 BN80B6	507
157	32.7	3.4	8.8	4940	S501_8.8 S1 M1LA4	510	S501_8.8 P80 BN80A4	511
158	32.6	0.9	5.8	1420	S201_5.8 S2 M2SA6	504	S201_5.8 P80 BN80B6	505
160	32.2	1.9	8.6	3540	S401_8.6 S1 M1LA4	508	S401_8.6 P80 BN80A4	509
186	27.6	2.1	4.9	1960	S301_4.9 S2 M2SA6	506	S301_4.9 P80 BN80B6	507
191	26.9	1.0	7.2	1370	S201_7.2 S1 M1LA4	504	S201_7.2 P80 BN80A4	505
193	26.7	1.1	4.8	1370	S201_4.8 S2 M2SA6	504	S201_4.8 P80 BN80B6	505
193	26.7	3.0	7.2	3350	S401_7.2 S1 M1LA4	508	S401_7.2 P80 BN80A4	509
195	26.4	1.9	7.1	1940	S301_7.1 S1 M1LA4	506	S301_7.1 P80 BN80A4	507
214	24.0	1.0	13.1	1900			S301_13.1 P71 BN71B2	507
218	23.6	3.4	12.9	4460	S501_12.9 S1 M1SD2	510	S501_12.9 P71 BN71B2	511
227	22.7	1.8	12.4	3190	S401_12.4 S1 M1SD2	508	S401_12.4 P71 BN71B2	509
233	22.1	2.6	3.9	1850	S301_3.9 S2 M2SA6	506	S301_3.9 P80 BN80B6	507
234	22.0	1.4	3.9	1300	S201_3.9 S2 M2SA6	504	S201_3.9 P80 BN80B6	505
236	21.8	2.3	5.8	1840	S301_5.8 S1 M1LA4	506	S301_5.8 P80 BN80A4	507
237	21.7	1.2	5.8	1310	S201_5.8 S1 M1LA4	504	S201_5.8 P80 BN80A4	505
263	19.5	2.0	10.7	3040	S401_10.7 S1 M1SD2	508	S401_10.7 P71 BN71B2	509
273	18.9	1.3	10.3	1780	S301_10.3 S1 M1SD2	506	S301_10.3 P71 BN71B2	507
280	18.4	2.7	4.9	1760	S301_4.9 S1 M1LA4	506	S301_4.9 P80 BN80A4	507
289	17.8	1.5	4.8	1250	S201_4.8 S1 M1LA4	504	S201_4.8 P80 BN80A4	505
296	17.4	1.7	3.1	1230	S201_3.1 S2 M2SA6	504	S201_3.1 P80 BN80B6	505
300	17.1	3.4	3.1	1720	S301_3.1 S2 M2SA6	506	S301_3.1 P80 BN80B6	507
316	16.3	1.5	8.9	1700	S301_8.9 S1 M1SD2	506	S301_8.9 P71 BN71B2	507
325	15.8	3.0	8.6	2850	S401_8.6 S1 M1SD2	508	S401_8.6 P71 BN71B2	509
350	14.7	3.4	3.9	1650	S301_3.9 S1 M1LA4	506	S301_3.9 P80 BN80A4	507
351	14.7	1.8	3.9	1190	S201_3.9 S1 M1LA4	504	S201_3.9 P80 BN80A4	505
377	13.6	2.2	2.4	1160	S201_2.4 S2 M2SA6	504	S201_2.4 P80 BN80B6	505
389	13.2	1.6	7.2	1160	S201_7.2 S1 M1SD2	504	S201_7.2 P71 BN71B2	505
396	13.0	3.1	7.1	1600	S301_7.1 S1 M1SD2	506	S301_7.1 P71 BN71B2	507
407	12.6	0.9	6.9	570	S101_6.9 S1 M1SD2	502	S101_6.9 P71 BN71B2	503
431	11.9	1.0	3.2	560	S101_3.2 S1 M1LA4	502	S101_3.2 P80 BN80A4	503
444	11.6	2.2	3.1	1120	S201_3.1 S1 M1LA4	504	S201_3.1 P80 BN80A4	505
460	11.2	1.1	6.1	570	S101_6.1 S1 M1SD2	502	S101_6.1 P71 BN71B2	503
483	10.7	2.0	5.8	1100	S201_5.8 S1 M1SD2	504	S201_5.8 P71 BN71B2	505
486	10.6	1.9	1.9	1080	S201_1.9 S2 M2SA6	504	S201_1.9 P80 BN80B6	505
491	10.5	1.1	1.9	540	S101_1.9 S2 M2SA6	502	S101_1.9 P80 BN80B6	503
504	10.2	3.4	1.8	1470	S301_1.8 S2 M2SA6	506	S301_1.8 P80 BN80B6	507
552	9.3	1.1	2.5	540	S101_2.5 S1 M1LA4	502	S101_2.5 P80 BN80A4	503
566	9.1	2.9	2.4	1050	S201_2.4 S1 M1LA4	504	S201_2.4 P80 BN80A4	505
589	8.7	2.4	4.8	1040	S201_4.8 S1 M1SD2	504	S201_4.8 P71 BN71B2	505
594	8.7	1.2	4.7	540	S101_4.7 S1 M1SD2	502	S101_4.7 P71 BN71B2	503
647	8.0	1.5	1.4	510	S101_1.4 S2 M2SA6	502	S101_1.4 P80 BN80B6	503



## 0.55 kW

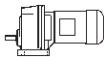

n <sub>2</sub> min <sup>-1</sup>	M <sub>2</sub> Nm	S	i	R <sub>n2</sub> N				
661	7.8	2.6	1.4	990	S201_1.4 S2 M2SA6	504	S201_1.4 P80 BN80B6	505
714	7.2	2.9	3.9	980	S201_3.9 S1 M1SD2	504	S201_3.9 P71 BN71B2	505
728	7.1	2.4	1.9	970	S201_1.9 S1 M1LA4	504	S201_1.9 P80 BN80A4	505
731	7.0	1.4	3.8	510	S101_3.8 S1 M1SD2	502	S101_3.8 P71 BN71B2	503
736	7.0	1.4	1.9	500	S101_1.9 S1 M1LA4	502	S101_1.9 P80 BN80A4	503
878	5.9	1.7	3.2	490	S101_3.2 S1 M1SD2	502	S101_3.2 P71 BN71B2	503
971	5.3	1.9	1.4	470	S101_1.4 S1 M1LA4	502	S101_1.4 P80 BN80A4	503
992	5.2	3.3	1.4	890			S201_1.4 P80 BN80A4	505
1124	4.6	1.7	2.5	460	S101_2.5 S1 M1SD2	502	S101_2.5 P71 BN71B2	503
1499	3.4	2.3	1.9	430	S101_1.9 S1 M1SD2	502	S101_1.9 P71 BN71B2	503
1977	2.6	3.1	1.4	390	S101_1.4 S1 M1SD2	502	S101_1.4 P71 BN71B2	503

## 0.75 kW

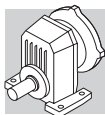

n <sub>2</sub> min <sup>-1</sup>	M <sub>2</sub> Nm	S	i	R <sub>n2</sub> N				
71	98.3	1.0	12.9	6170	S501_12.9 S2 M2SB6	510	S501_12.9 P90 BN90S6	511
88	79.8	1.4	10.5	5810	S501_10.5 S2 M2SB6	510	S501_10.5 P90 BN90S6	511
105	66.9	1.9	8.8	5520	S501_8.8 S2 M2SB6	510	S501_8.8 P90 BN90S6	511
107	65.9	1.1	8.6	3800	S401_8.6 S2 M2SB6	508	S401_8.6 P90 BN90S6	509
109	64.6	1.5	12.9	5460	S501_12.9 S2 M2SA4	510	S501_12.9 P80 BN80B4	511
124	56.5	2.5	7.4	5240	S501_7.4 S2 M2SB6	510	S501_7.4 P90 BN90S6	511
129	54.6	1.6	7.2	3700	S401_7.2 S2 M2SB6	508	S401_7.2 P90 BN90S6	509
130	54.1	1.1	7.1	2040	S301_7.1 S2 M2SB6	506	S301_7.1 P90 BN90S6	507
131	53.5	0.9	10.7	3670	S401_10.7 S2 M2SA4	508	S401_10.7 P80 BN80B4	509
134	52.4	2.1	10.5	5130	S501_10.5 S2 M2SA4	510	S501_10.5 P80 BN80B4	511
152	46.3	2.3	6.1	3530	S401_6.1 S2 M2SB6	508	S401_6.1 P90 BN90S6	509
152	46.2	3.2	6.1	4940	S501_6.1 S2 M2SB6	510	S501_6.1 P90 BN90S6	511
157	44.6	1.3	5.8	1960	S301_5.8 S2 M2SB6	506	S301_5.8 P90 BN90S6	507
160	44.0	2.5	8.8	4870	S501_8.8 S2 M2SA4	510	S501_8.8 P80 BN80B4	511
162	43.3	1.4	8.6	3460	S401_8.6 S2 M2SA4	508	S401_8.6 P80 BN80B4	509
186	37.6	1.5	4.9	1880	S301_4.9 S2 M2SB6	506	S301_4.9 P90 BN90S6	507
190	36.9	2.8	4.8	3300	S401_4.8 S2 M2SB6	508	S401_4.8 P90 BN90S6	509
196	35.9	2.2	7.2	3280	S401_7.2 S2 M2SA4	508	S401_7.2 P80 BN80B4	509
197	35.6	1.4	7.1	1860	S301_7.1 S2 M2SA4	506	S301_7.1 P80 BN80B4	507
217	32.3	2.5	12.9	4420	S501_12.9 S1 M1LA2	510	S501_12.9 P80 BN80A2	511
226	31.1	1.3	12.4	3150	S401_12.4 S1 M1LA2	508	S401_12.4 P80 BN80A2	509
231	30.4	3.0	6.1	3120	S401_6.1 S2 M2SA4	508	S401_6.1 P80 BN80B4	509
233	30.1	1.9	3.9	1780	S301_3.9 S2 M2SB6	506	S301_3.9 P90 BN90S6	507
234	30.0	1.0	3.9	1220	S201_3.9 S2 M2SB6	504	S201_3.9 P90 BN90S6	505
239	29.3	1.7	5.8	1780	S301_5.8 S2 M2SA4	506	S301_5.8 P80 BN80B4	507
263	26.7	1.5	10.7	3000	S401_10.7 S1 M1LA2	508	S401_10.7 P80 BN80A2	509
268	26.2	3.2	10.5	4140	S501_10.5 S1 M1LA2	510	S501_10.5 P80 BN80A2	511
272	25.8	0.9	10.3	1730	S301_10.3 S1 M1LA2	506	S301_10.3 P80 BN80A2	507
284	24.7	2.0	4.9	1700	S301_4.9 S2 M2SA4	506	S301_4.9 P80 BN80B4	507
294	23.9	1.1	4.8	1180	S201_4.8 S2 M2SA4	504	S201_4.8 P80 BN80B4	505
296	23.7	1.3	3.1	1160	S201_3.1 S2 M2SB6	504	S201_3.1 P90 BN90S6	505
300	23.4	2.5	3.1	1670	S301_3.1 S2 M2SB6	506	S301_3.1 P90 BN90S6	507
315	22.3	1.1	8.9	1660	S301_8.9 S1 M1LA2	506	S301_8.9 P80 BN80A2	507

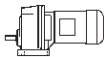



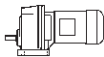

## 0.75 kW

n <sub>2</sub> min <sup>-1</sup>	M <sub>2</sub> Nm	S	i	R <sub>n2</sub> N				
324	21.7	2.2	8.6	2820	S401_8.6 S1 M1LA2	508	S401_8.6 P80 BN80A2	509
355	19.8	2.5	3.9	1600	S301_3.9 S2 M2SA4	506	S301_3.9 P80 BN80B4	507
356	19.7	1.3	3.9	1130	S201_3.9 S2 M2SA4	504	S201_3.9 P80 BN80B4	505
377	18.6	1.6	2.4	1110	S201_2.4 S2 M2SB6	504	S201_2.4 P90 BN90S6	505
380	18.5	3.1	2.4	1560	S301_2.4 S2 M2SB6	506	S301_2.4 P90 BN90S6	507
388	18.1	1.2	7.2	1120	S201_7.2 S1 M1LA2	504	S201_7.2 P80 BN80A2	505
395	17.8	2.3	7.1	1560	S301_7.1 S1 M1LA2	506	S301_7.1 P80 BN80A2	507
450	15.6	1.7	3.1	1070	S201_3.1 S2 M2SA4	504	S201_3.1 P80 BN80B4	505
457	15.4	3.3	3.1	1490	S301_3.1 S2 M2SA4	506	S301_3.1 P80 BN80B4	507
479	14.7	2.7	5.8	1480	S301_5.8 S1 M1LA2	506	S301_5.8 P80 BN80A2	507
481	14.6	1.4	5.8	1060	S201_5.8 S1 M1LA2	504	S201_5.8 P80 BN80A2	505
486	14.5	1.4	1.9	1040	S201_1.9 S2 M2SB6	504	S201_1.9 P90 BN90S6	505
504	13.9	2.5	1.8	1440	S301_1.8 S2 M2SB6	506	S301_1.8 P90 BN90S6	507
568	12.4	3.2	4.9	1410	S301_4.9 S1 M1LA2	506	S301_4.9 P80 BN80A2	507
574	12.2	2.1	2.4	1010	S201_2.4 S2 M2SA4	504	S201_2.4 P80 BN80B4	505
587	12.0	1.8	4.8	1010	S201_4.8 S1 M1LA2	504	S201_4.8 P80 BN80A2	505
647	10.8	1.1	1.4	460	S101_1.4 S2 M2SB6	502	S101_1.4 P90 BN90S6	503
654	10.7	3.3	1.4	1330	S301_1.4 S2 M2SB6	506	S301_1.4 P90 BN90S6	507
661	10.6	1.9	1.4	960	S201_1.4 S2 M2SB6	504	S201_1.4 P90 BN90S6	505
712	9.9	2.1	3.9	960	S201_3.9 S1 M1LA2	504	S201_3.9 P80 BN80A2	505
728	9.6	1.0	3.8	480	S101_3.8 S1 M1LA2	502	S101_3.8 P80 BN80A2	503
739	9.5	1.8	1.9	940	S201_1.9 S2 M2SA4	504	S201_1.9 P80 BN80B4	505
747	9.4	1.1	1.9	460	S101_1.9 S2 M2SA4	502	S101_1.9 P80 BN80B4	503
767	9.2	3.3	1.8	1280	S301_1.8 S2 M2SA4	506	S301_1.8 P80 BN80B4	507
875	8.0	1.2	3.2	460	S101_3.2 S1 M1LA2	502	S101_3.2 P80 BN80A2	503
900	7.8	2.7	3.1	900	S201_3.1 S1 M1LA2	504	S201_3.1 P80 BN80A2	505
985	7.1	1.4	1.4	440	S101_1.4 S2 M2SA4	502	S101_1.4 P80 BN80B4	503
1006	7.0	2.4	1.4	860	S201_1.4 S2 M2SA4	504	S201_1.4 P80 BN80B4	505
1120	6.3	1.3	2.5	440	S101_2.5 S1 M1LA2	502	S101_2.5 P80 BN80A2	503
1149	6.1	3.4	2.4	840	S201_2.4 S1 M1LA2	504	S201_2.4 P80 BN80A2	505
1478	4.7	2.7	1.9	780	S201_1.9 S1 M1LA2	504	S201_1.9 P80 BN80A2	505
1493	4.7	1.7	1.9	410	S101_1.9 S1 M1LA2	502	S101_1.9 P80 BN80A2	503
1970	3.6	2.2	1.4	380	S101_1.4 S1 M1LA2	502	S101_1.4 P80 BN80A2	503

## 1.1 kW

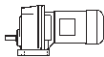

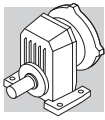

n <sub>2</sub> min <sup>-1</sup>	M <sub>2</sub> Nm	S	i	R <sub>n2</sub> N				
88	117.0	1.0	10.5	5650	S501_10.5 S3 M3SA6	510	S501_10.5 P90 BN90L6	511
105	98.1	1.3	8.8	5380	S501_8.8 S3 M3SA6	510	S501_8.8 P90 BN90L6	511
109	94.8	1.1	12.9	5320	S501_12.9 S2 M2SB4	510	S501_12.9 P90 BN90S4	511
124	82.8	1.7	7.4	5120	S501_7.4 S3 M3SA6	510	S501_7.4 P90 BN90L6	511
129	80.1	1.1	7.2	3550	S401_7.2 S3 M3SA6	508	S401_7.2 P90 BN90L6	509
134	76.9	1.4	10.5	5020	S501_10.5 S2 M2SB4	510	S501_10.5 P90 BN90S4	511
152	67.9	1.5	6.1	3400	S401_6.1 S3 M3SA6	508	S401_6.1 P90 BN90L6	509
152	67.8	2.2	6.1	4840	S501_6.1 S3 M3SA6	510	S501_6.1 P90 BN90L6	511
160	64.5	1.7	8.8	4770	S501_8.8 S2 M2SB4	510	S501_8.8 P90 BN90S4	511
162	63.5	0.9	8.6	3350	S401_8.6 S2 M2SB4	508	S401_8.6 P90 BN90S4	509
186	55.2	1.1	4.9	1740	S301_4.9 S3 M3SA6	506	S301_4.9 P90 BN90L6	507

## 1.1 kW



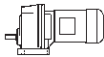

n <sub>2</sub> min <sup>-1</sup>	M <sub>2</sub> Nm	S	i	R <sub>n2</sub> N				
189	54.4	2.4	7.4	4530	S501_7.4 S2 M2SB4	510	S501_7.4 P90 BN90S4	511
190	54.1	1.9	4.8	3200	S401_4.8 S3 M3SA6	508	S401_4.8 P90 BN90L6	509
194	53.2	3.3	4.8	4500	S501_4.8 S3 M3SA6	510	S501_4.8 P90 BN90L6	511
196	52.6	1.5	7.2	3180	S401_7.2 S2 M2SB4	508	S401_7.2 P90 BN90S4	509
197	52.1	1.0	7.1	1730	S301_7.1 S2 M2SB4	506	S301_7.1 P90 BN90S4	507
217	47.4	1.7	12.9	4350	S501_12.9 S2 M2SA2	510	S501_12.9 P80 BN80B2	511
231	44.6	2.0	6.1	3040	S401_6.1 S2 M2SB4	508	S401_6.1 P90 BN90S4	509
231	44.5	2.9	6.1	4270	S501_6.1 S2 M2SB4	510	S501_6.1 P90 BN90S4	511
233	44.1	1.3	3.9	1670	S301_3.9 S3 M3SA6	506	S301_3.9 P90 BN90L6	507
239	43.0	1.2	5.8	1670	S301_5.8 S2 M2SB4	506	S301_5.8 P90 BN90S4	507
241	42.7	2.5	3.8	2990	S401_3.8 S3 M3SA6	508	S401_3.8 P90 BN90L6	509
263	39.2	1.0	10.7	2930	S401_10.7 S2 M2SA2	508	S401_10.7 P80 BN80B2	509
268	38.4	2.2	10.5	4090	S501_10.5 S2 M2SA2	510	S501_10.5 P80 BN80B2	511
284	36.3	1.4	4.9	1610	S301_4.9 S2 M2SB4	506	S301_4.9 P90 BN90S4	507
290	35.5	2.5	4.8	2850	S401_4.8 S2 M2SB4	508	S401_4.8 P90 BN90S4	509
300	34.3	1.7	3.1	1580	S301_3.1 S3 M3SA6	506	S301_3.1 P90 BN90L6	507
301	34.2	3.1	3.1	2810	S401_3.1 S3 M3SA6	508	S401_3.1 P90 BN90L6	509
319	32.2	2.6	8.8	3870	S501_8.8 S2 M2SA2	510	S501_8.8 P80 BN80B2	511
324	31.8	1.5	8.6	2760	S401_8.6 S2 M2SA2	508	S401_8.6 P80 BN80B2	509
355	29.0	1.7	3.9	1530	S301_3.9 S2 M2SB4	506	S301_3.9 P90 BN90S4	507
367	28.0	3.2	3.8	2650	S401_3.8 S2 M2SB4	508	S401_3.8 P90 BN90S4	509
377	27.3	1.1	2.4	1010	S201_2.4 S3 M3SA6	504	S201_2.4 P90 BN90L6	505
380	27.1	2.1	2.4	1490	S301_2.4 S3 M3SA6	506	S301_2.4 P90 BN90L6	507
391	26.3	2.4	7.2	2610	S401_7.2 S2 M2SA2	508	S401_7.2 P80 BN80B2	509
395	26.1	1.5	7.1	1500	S301_7.1 S2 M2SA2	506	S301_7.1 P80 BN80B2	507
450	22.9	1.1	3.1	990	S201_3.1 S2 M2SB4	504	S201_3.1 P90 BN90S4	505
457	22.5	2.2	3.1	1430	S301_3.1 S2 M2SB4	506	S301_3.1 P90 BN90S4	507
462	22.3	3.1	6.1	2490	S401_6.1 S2 M2SA2	508	S401_6.1 P80 BN80B2	509
479	21.5	1.9	5.8	1420	S301_5.8 S2 M2SA2	506	S301_5.8 P80 BN80B2	507
481	21.4	1.0	5.8	990	S201_5.8 S2 M2SA2	504	S201_5.8 P80 BN80B2	505
486	21.2	0.9	1.9	960	S201_1.9 S3 M3SA6	504	S201_1.9 P90 BN90L6	505
497	20.7	3.4	1.9	2420	S401_1.9 S3 M3SA6	508	S401_1.9 P90 BN90L6	509
504	20.4	1.7	1.8	1380	S301_1.8 S3 M3SA6	506	S301_1.8 P90 BN90L6	507
568	18.1	2.2	4.9	1360	S301_4.9 S2 M2SA2	506	S301_4.9 P80 BN80B2	507
574	17.9	1.5	2.4	940	S201_2.4 S2 M2SB4	504	S201_2.4 P90 BN90S4	505
578	17.8	2.8	2.4	1340	S301_2.4 S2 M2SB4	506	S301_2.4 P90 BN90S4	507
587	17.5	1.2	4.8	950	S201_4.8 S2 M2SA2	504	S201_4.8 P80 BN80B2	505
654	15.7	2.2	1.4	1290	S301_1.4 S3 M3SA6	506	S301_1.4 P90 BN90L6	507
661	15.6	1.3	1.4	900	S201_1.4 S3 M3SA6	504	S201_1.4 P90 BN90L6	505
710	14.5	2.8	3.9	1280	S301_3.9 S2 M2SA2	506	S301_3.9 P80 BN80B2	507
712	14.5	1.5	3.9	910	S201_3.9 S2 M2SA2	504	S201_3.9 P80 BN80B2	505
739	13.9	1.2	1.9	890	S201_1.9 S2 M2SB4	504	S201_1.9 P90 BN90S4	505
767	13.4	2.2	1.8	1240	S301_1.8 S2 M2SB4	506	S301_1.8 P90 BN90S4	507
900	11.4	1.8	3.1	860	S201_3.1 S2 M2SA2	504	S201_3.1 P80 BN80B2	505
985	10.4	1.0	1.4	390	S101_1.4 S2 M2SB4	502	S101_1.4 P90 BN90S4	503
995	10.3	2.9	1.4	1150	S301_1.4 S2 M2SB4	506	S301_1.4 P90 BN90S4	507
1006	10.2	1.7	1.4	820	S201_1.4 S2 M2SB4	504	S201_1.4 P90 BN90S4	505
1149	9.0	2.3	2.4	810	S201_2.4 S2 M2SA2	504	S201_2.4 P80 BN80B2	505
1478	7.0	1.9	1.9	750	S201_1.9 S2 M2SA2	504	S201_1.9 P80 BN80B2	505
1493	6.9	1.2	1.9	380	S101_1.9 S2 M2SA2	502	S101_1.9 P80 BN80B2	503
1970	5.2	1.5	1.4	350	S101_1.4 S2 M2SA2	502	S101_1.4 P80 BN80B2	503







## 1.1 kW

n <sub>2</sub> min <sup>-1</sup>	M <sub>2</sub> Nm	S	i	R <sub>n2</sub> N				
2013	5.1	2.5	1.4	690	S201_1.4 S2 M2SA2	504	S201_1.4 P80 BN80B2	505



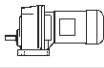

## 1.5 kW

n <sub>2</sub> min <sup>-1</sup>	M <sub>2</sub> Nm	S	i	R <sub>n2</sub> N				
88	117.0	1.0	10.5	5650	S501_10.5 S3 M3SA6	510	S501_10.5 P90 BN90L6	511
105	98.1	1.3	8.8	5380	S501_8.8 S3 M3SA6	510	S501_8.8 P90 BN90L6	511
109	94.8	1.1	12.9	5320	S501_12.9 S2 M2SB4	510	S501_12.9 P90 BN90S4	511
124	82.8	1.7	7.4	5120	S501_7.4 S3 M3SA6	510	S501_7.4 P90 BN90L6	511
129	80.1	1.1	7.2	3550	S401_7.2 S3 M3SA6	508	S401_7.2 P90 BN90L6	509
134	76.9	1.4	10.5	5020	S501_10.5 S2 M2SB4	510	S501_10.5 P90 BN90S4	511
152	67.9	1.5	6.1	3400	S401_6.1 S3 M3SA6	508	S401_6.1 P90 BN90L6	509
152	67.8	2.2	6.1	4840	S501_6.1 S3 M3SA6	510	S501_6.1 P90 BN90L6	511
160	64.5	1.7	8.8	4770	S501_8.8 S2 M2SB4	510	S501_8.8 P90 BN90S4	511
162	63.5	0.9	8.6	3350	S401_8.6 S2 M2SB4	508	S401_8.6 P90 BN90S4	509
186	55.2	1.1	4.9	1740	S301_4.9 S3 M3SA6	506	S301_4.9 P90 BN90L6	507
189	54.4	2.4	7.4	4530	S501_7.4 S2 M2SB4	510	S501_7.4 P90 BN90S4	511
190	54.1	1.9	4.8	3200	S401_4.8 S3 M3SA6	508	S401_4.8 P90 BN90L6	509
194	53.2	3.3	4.8	4500	S501_4.8 S3 M3SA6	510	S501_4.8 P90 BN90L6	511
196	52.6	1.5	7.2	3180	S401_7.2 S2 M2SB4	508	S401_7.2 P90 BN90S4	509
197	52.1	1.0	7.1	1730	S301_7.1 S2 M2SB4	506	S301_7.1 P90 BN90S4	507
217	47.4	1.7	12.9	4350	S501_12.9 S2 M2SA2	510	S501_12.9 P80 BN80B2	511
231	44.6	2.0	6.1	3040	S401_6.1 S2 M2SB4	508	S401_6.1 P90 BN90S4	509
231	44.5	2.9	6.1	4270	S501_6.1 S2 M2SB4	510	S501_6.1 P90 BN90S4	511
233	44.1	1.3	3.9	1670	S301_3.9 S3 M3SA6	506	S301_3.9 P90 BN90L6	507
239	43.0	1.2	5.8	1670	S301_5.8 S2 M2SB4	506	S301_5.8 P90 BN90S4	507
241	42.7	2.5	3.8	2990	S401_3.8 S3 M3SA6	508	S401_3.8 P90 BN90L6	509
263	39.2	1.0	10.7	2930	S401_10.7 S2 M2SA2	508	S401_10.7 P80 BN80B2	509
268	38.4	2.2	10.5	4090	S501_10.5 S2 M2SA2	510	S501_10.5 P80 BN80B2	511
284	36.3	1.4	4.9	1610	S301_4.9 S2 M2SB4	506	S301_4.9 P90 BN90S4	507
290	35.5	2.5	4.8	2850	S401_4.8 S2 M2SB4	508	S401_4.8 P90 BN90S4	509
300	34.3	1.7	3.1	1580	S301_3.1 S3 M3SA6	506	S301_3.1 P90 BN90L6	507
301	34.2	3.1	3.1	2810	S401_3.1 S3 M3SA6	508	S401_3.1 P90 BN90L6	509
319	32.2	2.6	8.8	3870	S501_8.8 S2 M2SA2	510	S501_8.8 P80 BN80B2	511
324	31.8	1.5	8.6	2760	S401_8.6 S2 M2SA2	508	S401_8.6 P80 BN80B2	509
355	29.0	1.7	3.9	1530	S301_3.9 S2 M2SB4	506	S301_3.9 P90 BN90S4	507
367	28.0	3.2	3.8	2650	S401_3.8 S2 M2SB4	508	S401_3.8 P90 BN90S4	509
377	27.3	1.1	2.4	1010	S201_2.4 S3 M3SA6	504	S201_2.4 P90 BN90L6	505
380	27.1	2.1	2.4	1490	S301_2.4 S3 M3SA6	506	S301_2.4 P90 BN90L6	507
391	26.3	2.4	7.2	2610	S401_7.2 S2 M2SA2	508	S401_7.2 P80 BN80B2	509
395	26.1	1.5	7.1	1500	S301_7.1 S2 M2SA2	506	S301_7.1 P80 BN80B2	507
450	22.9	1.1	3.1	990	S201_3.1 S2 M2SB4	504	S201_3.1 P90 BN90S4	505
457	22.5	2.2	3.1	1430	S301_3.1 S2 M2SB4	506	S301_3.1 P90 BN90S4	507
462	22.3	3.1	6.1	2490	S401_6.1 S2 M2SA2	508	S401_6.1 P80 BN80B2	509
479	21.5	1.9	5.8	1420	S301_5.8 S2 M2SA2	506	S301_5.8 P80 BN80B2	507
481	21.4	1.0	5.8	990	S201_5.8 S2 M2SA2	504	S201_5.8 P80 BN80B2	505
486	21.2	0.9	1.9	960	S201_1.9 S3 M3SA6	504	S201_1.9 P90 BN90L6	505
497	20.7	3.4	1.9	2420	S401_1.9 S3 M3SA6	508	S401_1.9 P90 BN90L6	509

## 1.5 kW

n <sub>2</sub> min <sup>-1</sup>	M <sub>2</sub> Nm	S	i	R <sub>n2</sub> N				
504	20.4	1.7	1.8	1380	S301_1.8 S3 M3SA6	506	S301_1.8 P90 BN90L6	507
568	18.1	2.2	4.9	1360	S301_4.9 S2 M2SA2	506	S301_4.9 P80 BN80B2	507
574	17.9	1.5	2.4	940	S201_2.4 S2 M2SB4	504	S201_2.4 P90 BN90S4	505
578	17.8	2.8	2.4	1340	S301_2.4 S2 M2SB4	506	S301_2.4 P90 BN90S4	507
587	17.5	1.2	4.8	950	S201_4.8 S2 M2SA2	504	S201_4.8 P80 BN80B2	505
654	15.7	2.2	1.4	1290	S301_1.4 S3 M3SA6	506	S301_1.4 P90 BN90L6	507
661	15.6	1.3	1.4	900	S201_1.4 S3 M3SA6	504	S201_1.4 P90 BN90L6	505
710	14.5	2.8	3.9	1280	S301_3.9 S2 M2SA2	506	S301_3.9 P80 BN80B2	507
712	14.5	1.5	3.9	910	S201_3.9 S2 M2SA2	504	S201_3.9 P80 BN80B2	505
739	13.9	1.2	1.9	890	S201_1.9 S2 M2SB4	504	S201_1.9 P90 BN90S4	505
767	13.4	2.2	1.8	1240	S301_1.8 S2 M2SB4	506	S301_1.8 P90 BN90S4	507
900	11.4	1.8	3.1	860	S201_3.1 S2 M2SA2	504	S201_3.1 P80 BN80B2	505
985	10.4	1.0	1.4	390	S101_1.4 S2 M2SB4	502	S101_1.4 P90 BN90S4	503
995	10.3	2.9	1.4	1150	S301_1.4 S2 M2SB4	506	S301_1.4 P90 BN90S4	507
1006	10.2	1.7	1.4	820	S201_1.4 S2 M2SB4	504	S201_1.4 P90 BN90S4	505
1149	9.0	2.3	2.4	810	S201_2.4 S2 M2SA2	504	S201_2.4 P80 BN80B2	505
1478	7.0	1.9	1.9	750	S201_1.9 S2 M2SA2	504	S201_1.9 P80 BN80B2	505
1493	6.9	1.2	1.9	380	S101_1.9 S2 M2SA2	502	S101_1.9 P80 BN80B2	503
1970	5.2	1.5	1.4	350	S101_1.4 S2 M2SA2	502	S101_1.4 P80 BN80B2	503
2013	5.1	2.5	1.4	690	S201_1.4 S2 M2SA2	504	S201_1.4 P80 BN80B2	505



## 2.2 kW

n <sub>2</sub> min <sup>-1</sup>	M <sub>2</sub> Nm	S	i	R <sub>n2</sub> N				
154	134.1	1.1	6.1	4520	S501_6.1 S3 M3LC6	510	S501_6.1 P112 BN112M6	511
191	108.1	1.2	7.4	4280	S501_7.4 S3 M3LA4	510	S501_7.4 P100 BN100LA4	511
192	107.0	1.0	4.8	2880	S401_4.8 S3 M3LC6	508	S401_4.8 P112 BN112M6	509
196	105.2	1.7	4.8	4230	S501_4.8 S3 M3LC6	510	S501_4.8 P112 BN112M6	511
232	88.6	1.0	6.1	2790	S401_6.1 S3 M3LA4	508	S401_6.1 P100 BN100LA4	509
233	88.4	1.5	6.1	4060	S501_6.1 S3 M3LA4	510	S501_6.1 P100 BN100LA4	511
242	85.1	2.1	3.8	4000	S501_3.8 S3 M3LC6	510	S501_3.8 P112 BN112M6	511
244	84.4	1.2	3.8	2730	S401_3.8 S3 M3LC6	508	S401_3.8 P112 BN112M6	509
269	76.6	1.1	10.5	3910	S501_10.5 S3 M3SA2	510	S501_10.5 P90 BN90L2	511
292	70.6	1.3	4.8	2640	S401_4.8 S3 M3LA4	508	S401_4.8 P100 BN100LA4	509
297	69.4	2.2	4.8	3790	S501_4.8 S3 M3LA4	510	S501_4.8 P100 BN100LA4	511
305	67.6	1.6	3.1	2590	S401_3.1 S3 M3LC6	508	S401_3.1 P112 BN112M6	509
306	67.4	2.4	3.0	3750	S501_3.0 S3 M3LC6	510	S501_3.0 P112 BN112M6	511
320	64.3	1.3	8.8	3730	S501_8.8 S3 M3SA2	510	S501_8.8 P90 BN90L2	511
367	56.1	2.7	3.8	3570	S501_3.8 S3 M3LA4	510	S501_3.8 P100 BN100LA4	511
370	55.7	1.6	3.8	2490	S401_3.8 S3 M3LA4	508	S401_3.8 P100 BN100LA4	509
380	54.2	1.8	7.4	3540	S501_7.4 S3 M3SA2	510	S501_7.4 P90 BN90L2	511
384	53.6	1.1	2.4	1260	S301_2.4 S3 M3LC6	506	S301_2.4 P112 BN112M6	507
386	53.3	2.8	2.4	3500	S501_2.4 S3 M3LC6	510	S501_2.4 P112 BN112M6	511
389	52.9	2.0	2.4	2450	S401_2.4 S3 M3LC6	508	S401_2.4 P112 BN112M6	509
393	52.4	1.2	7.2	2460	S401_7.2 S3 M3SA2	508	S401_7.2 P90 BN90L2	509
460	44.7	1.1	3.1	1240	S301_3.1 S3 M3LA4	506	S301_3.1 P100 BN100LA4	507
462	44.6	2.0	3.1	2340	S401_3.1 S3 M3LA4	508	S401_3.1 P100 BN100LA4	509
463	44.5	1.6	6.1	2360	S401_6.1 S3 M3SA2	508	S401_6.1 P90 BN90L2	509

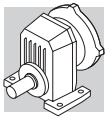







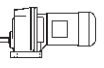

## 2.2 kW

n <sub>2</sub> min <sup>-1</sup>	M <sub>2</sub> Nm	S	i	R <sub>n2</sub> N				
463	44.4	3.2	3.0	3340	S501_3.0 S3 M3LA4	510	S501_3.0 P100 BN100LA4	511
464	44.4	2.3	6.1	3340	S501_6.1 S3 M3SA2	510	S501_6.1 P90 BN90L2	511
481	42.8	0.9	5.8	1250	S301_5.8 S3 M3SA2	506	S301_5.8 P90 BN90L2	507
502	41.0	1.7	1.9	2280	S401_1.9 S3 M3LC6	508	S401_1.9 P112 BN112M6	509
520	39.6	3.2	1.8	3210	S501_1.8 S3 M3LC6	510	S501_1.8 P112 BN112M6	511
570	36.1	1.1	4.9	1220	S301_4.9 S3 M3SA2	506	S301_4.9 P90 BN90L2	507
581	35.4	2.0	4.8	2210	S401_4.8 S3 M3SA2	508	S401_4.8 P90 BN90L2	509
582	35.4	1.4	2.4	1190	S301_2.4 S3 M3LA4	506	S301_2.4 P100 BN100LA4	507
590	34.9	2.6	2.4	2200	S401_2.4 S3 M3LA4	508	S401_2.4 P100 BN100LA4	509
592	34.8	3.4	4.8	3110	S501_4.8 S3 M3SA2	510	S501_4.8 P90 BN90L2	511
661	31.2	1.1	1.4	1140	S301_1.4 S3 M3LC6	506	S301_1.4 P112 BN112M6	507
682	30.2	2.3	1.4	2090	S401_1.4 S3 M3LC6	508	S401_1.4 P112 BN112M6	509
712	28.9	1.4	3.9	1160	S301_3.9 S3 M3SA2	506	S301_3.9 P90 BN90L2	507
737	27.9	2.5	3.8	2070	S401_3.8 S3 M3SA2	508	S401_3.8 P90 BN90L2	509
761	27.0	2.2	1.9	2040	S401_1.9 S3 M3LA4	508	S401_1.9 P100 BN100LA4	509
772	26.7	1.1	1.8	1120	S301_1.8 S3 M3LA4	506	S301_1.8 P100 BN100LA4	507
903	22.8	0.9	3.1	730	S201_3.1 S3 M3SA2	504	S201_3.1 P90 BN90L2	505
918	22.4	1.8	3.1	1100	S301_3.1 S3 M3SA2	506	S301_3.1 P90 BN90L2	507
921	22.4	3.1	3.1	1940	S401_3.1 S3 M3SA2	508	S401_3.1 P90 BN90L2	509
1002	20.6	1.5	1.4	1050	S301_1.4 S3 M3LA4	506	S301_1.4 P100 BN100LA4	507
1034	19.9	3.0	1.4	1860	S401_1.4 S3 M3LA4	508	S401_1.4 P100 BN100LA4	509
1153	17.9	1.2	2.4	710	S201_2.4 S3 M3SA2	504	S201_2.4 P90 BN90L2	505
1161	17.7	2.3	2.4	1030	S301_2.4 S3 M3SA2	506	S301_2.4 P90 BN90L2	507
1483	13.9	0.9	1.9	670	S201_1.9 S3 M3SA2	504	S201_1.9 P90 BN90L2	505
1539	13.4	1.8	1.8	960	S301_1.8 S3 M3SA2	506	S301_1.8 P90 BN90L2	507
1997	10.3	2.3	1.4	890	S301_1.4 S3 M3SA2	506	S301_1.4 P90 BN90L2	507
2020	10.2	1.3	1.4	630	S201_1.4 S3 M3SA2	504	S201_1.4 P90 BN90L2	505



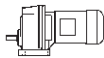

## 3.0 kW

n <sub>2</sub> min <sup>-1</sup>	M <sub>2</sub> Nm	S	i	R <sub>n2</sub> N				
198	141.9	1.2	4.8	4040	S501_4.8 S4 M4SA6	510	S501_4.8 P132 BN132S6	511
233	120.6	1.1	6.1	3910	S501_6.1 S3 M3LB4	510	S501_6.1 P100 BN100LB4	511
245	114.8	1.5	3.8	3840	S501_3.8 S4 M4SA6	510	S501_3.8 P132 BN132S6	511
247	113.9	0.9	3.8	2550	S401_3.8 S4 M4SA6	508	S401_3.8 P132 BN132S6	509
292	96.2	0.9	4.8	2490	S401_4.8 S3 M3LB4	508	S401_4.8 P100 BN100LB4	509
297	94.6	1.6	4.8	3670	S501_4.8 S3 M3LB4	510	S501_4.8 P100 BN100LB4	511
308	91.2	1.2	3.1	2440	S401_3.1 S4 M4SA6	508	S401_3.1 P132 BN132S6	509
309	90.9	1.8	3.0	3630	S501_3.0 S4 M4SA6	510	S501_3.0 P132 BN132S6	511
326	86.1	1.0	8.8	3600	S501_8.8 S3 M3LA2	510	S501_8.8 P100 BN100L2	511
367	76.5	2.0	3.8	3470	S501_3.8 S3 M3LB4	510	S501_3.8 P100 BN100LB4	511
370	75.9	1.2	3.8	2370	S401_3.8 S3 M3LB4	508	S401_3.8 P100 BN100LB4	509
386	72.6	1.4	7.4	3440	S501_7.4 S3 M3LA2	510	S501_7.4 P100 BN100L2	511
390	71.9	2.1	2.4	3390	S501_2.4 S4 M4SA6	510	S501_2.4 P132 BN132S6	511
393	71.4	1.5	2.4	2320	S401_2.4 S4 M4SA6	508	S401_2.4 P132 BN132S6	509
462	60.8	1.5	3.1	2250	S401_3.1 S3 M3LB4	508	S401_3.1 P100 BN100LB4	509
463	60.6	2.3	3.0	3260	S501_3.0 S3 M3LB4	510	S501_3.0 P100 BN100LB4	511
471	59.6	1.2	6.1	2260	S401_6.1 S3 M3LA2	508	S401_6.1 P100 BN100L2	509

### 3.0 kW



n <sub>2</sub> min <sup>-1</sup>	M <sub>2</sub> Nm	S	i	R <sub>n2</sub> N				
472	59.4	1.7	6.1	3260	S501_6.1 S3 M3LA2	510	S501_6.1 P100 BN100L2	511
508	55.3	1.3	1.9	2170	S401_1.9 S4 M4SA6	508	S401_1.9 P132 BN132S6	509
526	53.4	2.3	1.8	3120	S501_1.8 S4 M4SA6	510	S501_1.8 P132 BN132S6	511
582	48.2	1.0	2.4	1080	S301_2.4 S3 M3LB4	506	S301_2.4 P100 BN100LB4	507
586	47.9	2.7	2.4	3040	S501_2.4 S3 M3LB4	510	S501_2.4 P100 BN100LB4	511
590	47.6	1.9	2.4	2120	S401_2.4 S3 M3LB4	508	S401_2.4 P100 BN100LB4	509
592	47.4	1.5	4.8	2130	S401_4.8 S3 M3LA2	508	S401_4.8 P100 BN100L2	509
602	46.6	2.6	4.8	3030	S501_4.8 S3 M3LA2	510	S501_4.8 P100 BN100L2	511
661	42.4	2.9	1.4	2920	S501_1.4 S4 M4SA6	510	S501_1.4 P132 BN132S6	511
689	40.7	1.7	1.4	2010	S401_1.4 S4 M4SA6	508	S401_1.4 P132 BN132S6	509
725	38.7	1.0	3.9	1070	S301_3.9 S3 M3LA2	506	S301_3.9 P100 BN100L2	507
744	37.7	3.2	3.8	2850	S501_3.8 S3 M3LA2	510	S501_3.8 P100 BN100L2	511
750	37.4	1.9	3.8	2000	S401_3.8 S3 M3LA2	508	S401_3.8 P100 BN100L2	509
761	36.9	1.6	1.9	1970	S401_1.9 S3 M3LB4	508	S401_1.9 P100 BN100LB4	509
789	35.6	3.1	1.8	2780	S501_1.8 S3 M3LB4	510	S501_1.8 P100 BN100LB4	511
934	30.1	1.3	3.1	1020	S301_3.1 S3 M3LA2	506	S301_3.1 P100 BN100L2	507
937	30.0	2.3	3.1	1880	S401_3.1 S3 M3LA2	508	S401_3.1 P100 BN100L2	509
1002	28.0	1.1	1.4	980	S301_1.4 S3 M3LB4	506	S301_1.4 P100 BN100LB4	507
1034	27.2	2.2	1.4	1820	S401_1.4 S3 M3LB4	508	S401_1.4 P100 BN100LB4	509
1181	23.8	1.7	2.4	980	S301_2.4 S3 M3LA2	506	S301_2.4 P100 BN100L2	507
1196	23.5	3.0	2.4	1760	S401_2.4 S3 M3LA2	508	S401_2.4 P100 BN100L2	509
1544	18.2	2.6	1.9	1630	S401_1.9 S3 M3LA2	508	S401_1.9 P100 BN100L2	509
1566	17.9	1.3	1.8	910	S301_1.8 S3 M3LA2	506	S301_1.8 P100 BN100L2	507
2032	13.8	1.7	1.4	850	S301_1.4 S3 M3LA2	506	S301_1.4 P100 BN100L2	507
2056	13.7	1.0	1.4	580	S201_1.4 S3 M3LA2	504	S201_1.4 P100 BN100L2	505

### 4.0 kW

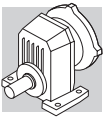

n <sub>2</sub> min <sup>-1</sup>	M <sub>2</sub> Nm	S	i	R <sub>n2</sub> N				
200	187.2	0.9	4.8	3810	S501_4.8 S4 M4LA6	510	S501_4.8 P132 BN132MA6	511
247	151.4	1.2	3.8	3650	S501_3.8 S4 M4LA6	510	S501_3.8 P132 BN132MA6	511
293	127.9	1.2	4.8	3530	S501_4.8 S3 M3LC4	510	S501_4.8 P112 BN112M4	511
312	119.9	1.3	3.0	3470	S501_3.0 S4 M4LA6	510	S501_3.0 P132 BN132MA6	511
362	103.5	1.4	3.8	3360	S501_3.8 S3 M3LC4	510	S501_3.8 P112 BN112M4	511
388	96.5	1.0	7.4	3320	S501_7.4 S3 M3LB2	510	S501_7.4 P112 BN112M2	511
395	94.9	1.6	2.4	3270	S501_2.4 S4 M4LA6	510	S501_2.4 P132 BN132MA6	511
397	94.2	1.1	2.4	2180	S401_2.4 S4 M4LA6	508	S401_2.4 P132 BN132MA6	509
455	82.2	1.1	3.1	2130	S401_3.1 S3 M3LC4	508	S401_3.1 P112 BN112M4	509
457	82.0	1.7	3.0	3170	S501_3.0 S3 M3LC4	510	S501_3.0 P112 BN112M4	511
474	79.0	1.3	6.1	3160	S501_6.1 S3 M3LB2	510	S501_6.1 P112 BN112M2	511
513	73.0	1.0	1.9	2050	S401_1.9 S4 M4LA6	508	S401_1.9 P132 BN132MA6	509
531	70.5	1.8	1.8	3020	S501_1.8 S4 M4LA6	510	S501_1.8 P132 BN132MA6	511
577	64.8	2.0	2.4	2970	S501_2.4 S3 M3LC4	510	S501_2.4 P112 BN112M4	511
581	64.4	1.4	2.4	2030	S401_2.4 S3 M3LC4	508	S401_2.4 P112 BN112M4	509
594	63.0	1.1	4.8	2040	S401_4.8 S3 M3LB2	508	S401_4.8 P112 BN112M2	509
604	62.0	1.9	4.8	2960	S501_4.8 S3 M3LB2	510	S501_4.8 P112 BN112M2	511
669	56.0	2.2	1.4	2830	S501_1.4 S4 M4LA6	510	S501_1.4 P132 BN132MA6	511
697	53.7	1.3	1.4	1920	S401_1.4 S4 M4LA6	508	S401_1.4 P132 BN132MA6	509

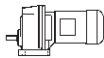



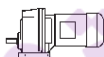

## 4.0 kW

n <sub>2</sub> min <sup>-1</sup>	M <sub>2</sub> Nm	S	i	R <sub>n2</sub> N				
747	50.1	2.4	3.8	2790	S501_3.8 S3 M3LB2	510	S501_3.8 P112 BN112M2	511
751	49.9	1.2	1.9	1900	S401_1.9 S3 M3LC4	508	S401_1.9 P112 BN112M4	509
753	49.7	1.4	3.8	1930	S401_3.8 S3 M3LB2	508	S401_3.8 P112 BN112M2	509
777	48.2	2.3	1.8	2730	S501_1.8 S3 M3LC4	510	S501_1.8 P112 BN112M4	511
937	39.9	1.0	3.1	940	S301_3.1 S3 M3LB2	506	S301_3.1 P112 BN112M2	507
940	39.8	1.8	3.1	1820	S401_3.1 S3 M3LB2	508	S401_3.1 P112 BN112M2	509
943	39.7	2.8	3.0	2610	S501_3.0 S3 M3LB2	510	S501_3.0 P112 BN112M2	511
978	38.3	2.9	1.4	2560	S501_1.4 S3 M3LC4	510	S501_1.4 P112 BN112M4	511
1019	36.7	1.6	1.4	1760	S401_1.4 S3 M3LC4	508	S401_1.4 P112 BN112M4	509
1185	31.6	1.3	2.4	910	S301_2.4 S3 M3LB2	506	S301_2.4 P112 BN112M2	507
1192	31.4	3.2	2.4	2430	S501_2.4 S3 M3LB2	510	S501_2.4 P112 BN112M2	511
1200	31.2	2.2	2.4	1710	S401_2.4 S3 M3LB2	508	S401_2.4 P112 BN112M2	509
1550	24.2	2.0	1.9	1590	S401_1.9 S3 M3LB2	508	S401_1.9 P112 BN112M2	509
1572	23.8	1.0	1.8	860	S301_1.8 S3 M3LB2	506	S301_1.8 P112 BN112M2	507
2039	18.4	1.3	1.4	810	S301_1.4 S3 M3LB2	506	S301_1.4 P112 BN112M2	507
2105	17.8	2.7	1.4	1460	S401_1.4 S3 M3LB2	508	S401_1.4 P112 BN112M2	509



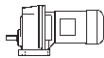

## 5.5 kW

n <sub>2</sub> min <sup>-1</sup>	M <sub>2</sub> Nm	S	i	R <sub>n2</sub> N				
311	165.8	1.0	3.0	3260	S501_3.0 S4 M4LB6	510	S501_3.0 P132 BN132MB6	511
375	137.3	1.1	3.8	3150	S501_3.8 S4 M4SA4	510	S501_3.8 P132 BN132S4	511
393	131.1	1.1	2.4	3090	S501_2.4 S4 M4LB6	510	S501_2.4 P132 BN132MB6	511
473	108.8	1.3	3.0	3000	S501_3.0 S4 M4SA4	510	S501_3.0 P132 BN132S4	511
477	107.9	0.9	6.1	3020	S501_6.1 S4 M4SA2	510	S501_6.1 P132 BN132SA2	511
529	97.4	1.3	1.8	2880	S501_1.8 S4 M4LB6	510	S501_1.8 P132 BN132MB6	511
598	86.1	1.5	2.4	2830	S501_2.4 S4 M4SA4	510	S501_2.4 P132 BN132S4	511
602	85.5	1.1	2.4	1870	S401_2.4 S4 M4SA4	508	S401_2.4 P132 BN132S4	509
608	84.6	1.4	4.8	2840	S501_4.8 S4 M4SA2	510	S501_4.8 P132 BN132SA2	511
665	77.4	1.6	1.4	2720	S501_1.4 S4 M4LB6	510	S501_1.4 P132 BN132MB6	511
693	74.3	0.9	1.4	1780	S401_1.4 S4 M4LB6	508	S401_1.4 P132 BN132MB6	509
752	68.4	1.8	3.8	2690	S501_3.8 S4 M4SA2	510	S501_3.8 P132 BN132SA2	511
758	67.9	1.0	3.8	1810	S401_3.8 S4 M4SA2	508	S401_3.8 P132 BN132SA2	509
778	66.2	0.9	1.9	1770	S401_1.9 S4 M4SA4	508	S401_1.9 P132 BN132S4	509
805	63.9	1.7	1.8	2610	S501_1.8 S4 M4SA4	510	S501_1.8 P132 BN132S4	511
947	54.4	1.3	3.1	1730	S401_3.1 S4 M4SA2	508	S401_3.1 P132 BN132SA2	509
950	54.2	2.0	3.0	2530	S501_3.0 S4 M4SA2	510	S501_3.0 P132 BN132SA2	511
1013	50.8	2.2	1.4	2450	S501_1.4 S4 M4SA4	510	S501_1.4 P132 BN132S4	511
1056	48.7	1.2	1.4	1660	S401_1.4 S4 M4SA4	508	S401_1.4 P132 BN132S4	509
1200	42.9	2.3	2.4	2370	S501_2.4 S4 M4SA2	510	S501_2.4 P132 BN132SA2	511
1209	42.6	1.6	2.4	1640	S401_2.4 S4 M4SA2	508	S401_2.4 P132 BN132SA2	509
1561	33.0	1.5	1.9	1530	S401_1.9 S4 M4SA2	508	S401_1.9 P132 BN132SA2	509
1616	31.8	2.7	1.8	2170	S501_1.8 S4 M4SA2	510	S501_1.8 P132 BN132SA2	511
2034	25.3	3.4	1.4	2030	S501_1.4 S4 M4SA2	510	S501_1.4 P132 BN132SA2	511
2119	24.3	2.0	1.4	1410	S401_1.4 S4 M4SA2	508	S401_1.4 P132 BN132SA2	509

## 7.5 kW

n <sub>2</sub> min <sup>-1</sup>	M <sub>2</sub> Nm	S	i	R <sub>n2</sub> N				
473	148.4	0.9	3.0	2810	S501_3.0 S4 M4LA4	510	S501_3.0 P132 BN132MA4	511
534	131.4	1.0	1.8	2690			S501_1.8 P160 BN160M6	511
598	117.3	1.1	2.4	2670	S501_2.4 S4 M4LA4	510	S501_2.4 P132 BN132MA4	511
611	115.0	1.0	4.8	2690	S501_4.8 S4 M4SB2	510	S501_4.8 P132 BN132SB2	511
672	104.4	1.2	1.4	2560			S501_1.4 P160 BN160M6	511
755	93.0	1.3	3.8	2570	S501_3.8 S4 M4SB2	510	S501_3.8 P132 BN132SB2	511
805	87.1	1.3	1.8	2490	S501_1.8 S4 M4LA4	510	S501_1.8 P132 BN132MA4	511
950	73.9	0.9	3.1	1610	S401_3.1 S4 M4SB2	508	S401_3.1 P132 BN132SB2	509
953	73.7	1.5	3.0	2440	S501_3.0 S4 M4SB2	510	S501_3.0 P132 BN132SB2	511
1013	69.3	1.6	1.4	2350	S501_1.4 S4 M4LA4	510	S501_1.4 P132 BN132MA4	511
1056	66.5	0.9	1.4	1540	S401_1.4 S4 M4LA4	508	S401_1.4 P132 BN132MA4	509
1205	58.3	1.7	2.4	2290	S501_2.4 S4 M4SB2	510	S501_2.4 P132 BN132SB2	511
1213	57.9	1.2	2.4	1540	S401_2.4 S4 M4SB2	508	S401_2.4 P132 BN132SB2	509
1566	44.8	1.1	1.9	1450	S401_1.9 S4 M4SB2	508	S401_1.9 P132 BN132SB2	509
1622	43.3	2.0	1.8	2110	S501_1.8 S4 M4SB2	510	S501_1.8 P132 BN132SB2	511
2041	34.4	2.5	1.4	1980	S501_1.4 S4 M4SB2	510	S501_1.4 P132 BN132SB2	511
2127	33.0	1.5	1.4	1350	S401_1.4 S4 M4SB2	508	S401_1.4 P132 BN132SB2	509

## 9.2 kW

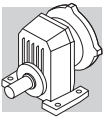

n <sub>2</sub> min <sup>-1</sup>	M <sub>2</sub> Nm	S	i	R <sub>n2</sub> N				
598	143.9	0.9	2.4	2530	S501_2.4 S4 M4LB4	510	S501_2.4 P132 BN132MB4	511
755	114.1	1.1	3.8	2470	S501_3.8 S4 M4LA2	510	S501_3.8 P132 BN132M2	511
805	106.9	1.0	1.8	2390	S501_1.8 S4 M4LB4	510	S501_1.8 P132 BN132MB4	511
953	90.4	1.2	3.0	2360	S501_3.0 S4 M4LA2	510	S501_3.0 P132 BN132M2	511
1013	85.0	1.3	1.4	2270	S501_1.4 S4 M4LB4	510	S501_1.4 P132 BN132MB4	511
1205	71.5	1.4	2.4	2220	S501_2.4 S4 M4LA2	510	S501_2.4 P132 BN132M2	511
1213	71.0	1.0	2.4	1460	S401_2.4 S4 M4LA2	508	S401_2.4 P132 BN132M2	509
1622	53.1	1.6	1.8	2060	S501_1.8 S4 M4LA2	510	S501_1.8 P132 BN132M2	511
2041	42.2	2.0	1.4	1930	S501_1.4 S4 M4LA2	510	S501_1.4 P132 BN132M2	511
2127	40.5	1.2	1.4	1300	S401_1.4 S4 M4LA2	508	S401_1.4 P132 BN132M2	509



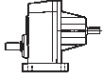

74 GEARBOX RATING CHARTS

**S 10**

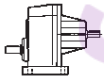

**21 Nm**



	i	n <sub>1</sub> = 2800 min <sup>-1</sup>					n <sub>1</sub> = 1400 min <sup>-1</sup>					
		n <sub>2</sub> min <sup>-1</sup>	M <sub>n2</sub> Nm	P <sub>n1</sub> kW	R <sub>n1</sub> N	R <sub>n2</sub> N	n <sub>2</sub> min <sup>-1</sup>	M <sub>n2</sub> Nm	P <sub>n1</sub> kW	R <sub>n1</sub> N	R <sub>n2</sub> N	
S 10 1_1.4	1.4	1972	8.0	1.7	800	310	986	10.0	1.1	800	390	503
S 10 1_1.9	1.9	1489	8.0	1.3	800	360	745	10.0	0.80	800	460	
S 10 1_2.5	2.5	1120	8.0	0.96	800	420	560	10.0	0.60	800	520	
S 10 1_3.2	3.2	875	10.0	0.93	800	440	438	12.0	0.56	800	560	
S 10 1_3.8	3.8	727	10.0	0.78	800	480	364	12.0	0.47	800	610	
S 10 1_4.7	4.7	592	10.0	0.63	800	520	296	12.0	0.38	800	660	
S 10 1_6.1	6.1	458	12.0	0.59	800	560	229	15.0	0.37	800	710	
S 10 1_6.9	6.9	406	12.0	0.52	800	580	203	15.0	0.33	800	740	
S 10 1_8.9	8.9	315	8.0	0.27	800	700	158	10.0	0.17	800	880	
S 10 1_10.3	10.3	272	8.0	0.23	800	740	136	10.0	0.15	800	930	
S 10 1_12.3	12.3	227	8.0	0.19	800	800	114	10.0	0.12	800	1000	

	i	n <sub>1</sub> = 900 min <sup>-1</sup>					n <sub>1</sub> = 500 min <sup>-1</sup>					
		n <sub>2</sub> min <sup>-1</sup>	M <sub>n2</sub> Nm	P <sub>n1</sub> kW	R <sub>n1</sub> N	R <sub>n2</sub> N	n <sub>2</sub> min <sup>-1</sup>	M <sub>n2</sub> Nm	P <sub>n1</sub> kW	R <sub>n1</sub> N	R <sub>n2</sub> N	
S 10 1_1.4	1.4	634	12.0	0.81	800	450	352	14.0	0.53	800	560	503
S 10 1_1.9	1.9	479	12.0	0.61	800	520	266	14.0	0.40	800	640	
S 10 1_2.5	2.5	360	12.0	0.46	800	600	200	14.0	0.30	800	740	
S 10 1_3.2	3.2	281	14.0	0.42	800	650	156	17.0	0.28	800	790	
S 10 1_3.8	3.8	234	14.0	0.35	800	700	130	17.0	0.24	800	850	
S 10 1_4.7	4.7	190	14.0	0.28	800	770	106	17.0	0.19	800	930	
S 10 1_6.1	6.1	147	17.0	0.27	800	820	82	21	0.18	800	1000	
S 10 1_6.9	6.9	130	17.0	0.24	800	860	72	21	0.16	800	1040	
S 10 1_8.9	8.9	101	12.0	0.13	800	1020	56	14.0	0.08	800	1200	
S 10 1_10.3	10.3	87	12.0	0.11	800	1080	49	14.0	0.07	800	1200	
S 10 1_12.3	12.3	73	12.0	0.09	800	1160	41	14.0	0.06	800	1200	

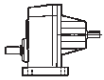
# S 20

# 37 Nm

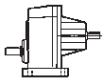

	i	n <sub>1</sub> = 2800 min <sup>-1</sup>					n <sub>1</sub> = 1400 min <sup>-1</sup>					
		n <sub>2</sub> min <sup>-1</sup>	M <sub>n2</sub> Nm	P <sub>n1</sub> kW	R <sub>n1</sub> N	R <sub>n2</sub> N	n <sub>2</sub> min <sup>-1</sup>	M <sub>n2</sub> Nm	P <sub>n1</sub> kW	R <sub>n1</sub> N	R <sub>n2</sub> N	
S 20 1_1.4	1.4	2014	13.0	2.8	1000	590	1007	17.0	1.8	1000	740	505
S 20 1_1.9	1.9	1481	13.0	2.1	1000	680	741	17.0	1.3	1000	860	
S 20 1_2.4	2.4	1148	21	2.6	640	680	574	26	1.6	850	860	
S 20 1_3.1	3.1	900	21	2.0	730	750	450	26	1.3	960	950	
S 20 1_3.9	3.9	712	21	1.6	820	840	356	26	0.99	1000	1060	
S 20 1_4.8	4.8	587	21	1.3	910	920	294	26	0.82	1000	1160	
S 20 1_5.8	5.8	481	21	1.1	960	1000	241	26	0.67	1000	1260	
S 20 1_7.2	7.2	388	21	0.87	980	1090	194	26	0.54	1000	1370	
S 20 1_8.5	8.5	329	13.0	0.46	1000	1240	165	17.0	0.30	1000	1500	
S 20 1_10.8	10.8	260	13.0	0.36	1000	1350	130	17.0	0.24	1000	1500	
S 20 1_12.4	12.4	225	13.0	0.31	1000	1430	113	17.0	0.20	1000	1500	

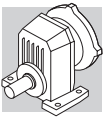

	i	n <sub>1</sub> = 900 min <sup>-1</sup>					n <sub>1</sub> = 500 min <sup>-1</sup>					
		n <sub>2</sub> min <sup>-1</sup>	M <sub>n2</sub> Nm	P <sub>n1</sub> kW	R <sub>n1</sub> N	R <sub>n2</sub> N	n <sub>2</sub> min <sup>-1</sup>	M <sub>n2</sub> Nm	P <sub>n1</sub> kW	R <sub>n1</sub> N	R <sub>n2</sub> N	
S 20 1_1.4	1.4	647	20	1.4	1000	850	360	24	0.92	1000	1040	505
S 20 1_1.9	1.9	476	20	1.0	1000	990	265	24	0.68	1000	1210	
S 20 1_2.4	2.4	369	30	1.2	990	990	205	37	0.81	1000	1200	
S 20 1_3.1	3.1	289	30	0.93	1000	1110	161	37	0.64	1000	1340	
S 20 1_3.9	3.9	229	30	0.73	1000	1230	127	37	0.50	1000	1490	
S 20 1_4.8	4.8	189	30	0.60	1000	1350	105	37	0.41	1000	1500	
S 20 1_5.8	5.8	155	30	0.50	1000	1460	86	37	0.34	1000	1500	
S 20 1_7.2	7.2	125	30	0.40	1000	1500	69	37	0.27	1000	1500	
S 20 1_8.5	8.5	106	20	0.23	1000	1500	59	24	0.15	1000	1500	
S 20 1_10.8	10.8	84	20	0.18	1000	1500	47	24	0.12	1000	1500	
S 20 1_12.4	12.4	72	20	0.15	1000	1500	40	24	0.10	1000	1500	

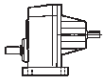

# S 30

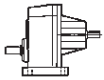

# 70 Nm



	i	n <sub>1</sub> = 2800 min <sup>-1</sup>					n <sub>1</sub> = 1400 min <sup>-1</sup>					
		n <sub>2</sub> min <sup>-1</sup>	M <sub>n2</sub> Nm	P <sub>n1</sub> kW	R <sub>n1</sub> N	R <sub>n2</sub> N	n <sub>2</sub> min <sup>-1</sup>	M <sub>n2</sub> Nm	P <sub>n1</sub> kW	R <sub>n1</sub> N	R <sub>n2</sub> N	
S 30 1_1.4	1.4	1986	24	5.1	1500	770	993	30	3.2	1500	970	507
S 30 1_1.8	1.8	1530	24	3.9	1500	870	765	30	2.5	1500	1090	
S 30 1_2.4	2.4	1157	40	4.9	1270	850	579	50	3.1	1500	1070	
S 30 1_3.1	3.1	915	40	3.9	1470	950	458	50	2.4	1500	1200	
S 30 1_3.9	3.9	711	40	3.0	1500	1070	355	50	1.9	1500	1360	
S 30 1_4.9	4.9	568	40	2.4	1500	1190	284	50	1.5	1500	1500	
S 30 1_5.8	5.8	479	40	2.0	1500	1280	239	50	1.3	1500	1610	
S 30 1_7.1	7.1	395	40	1.7	1500	1390	197	50	1.1	1500	1750	
S 30 1_8.9	8.9	315	24	0.81	1500	1650	157	30	0.50	1500	2080	
S 30 1_10.3	10.3	272	24	0.70	1500	1740	136	30	0.44	1500	2190	
S 30 1_13.1	13.1	213	24	0.55	1500	1900	107	30	0.34	1500	2400	

	i	n <sub>1</sub> = 900 min <sup>-1</sup>					n <sub>1</sub> = 500 min <sup>-1</sup>					
		n <sub>2</sub> min <sup>-1</sup>	M <sub>n2</sub> Nm	P <sub>n1</sub> kW	R <sub>n1</sub> N	R <sub>n2</sub> N	n <sub>2</sub> min <sup>-1</sup>	M <sub>n2</sub> Nm	P <sub>n1</sub> kW	R <sub>n1</sub> N	R <sub>n2</sub> N	
S 30 1_1.4	1.4	638	35	2.4	1500	1120	355	42	1.6	1500	1360	507
S 30 1_1.8	1.8	492	35	1.8	1500	1260	273	42	1.2	1500	1540	
S 30 1_2.4	2.4	372	58	2.3	1500	1240	207	70	1.5	1500	1510	
S 30 1_3.1	3.1	294	58	1.8	1500	1390	163	70	1.2	1500	1700	
S 30 1_3.9	3.9	228	58	1.4	1500	1570	127	70	0.95	1500	1920	
S 30 1_4.9	4.9	183	58	1.1	1500	1740	101	70	0.76	1500	2120	
S 30 1_5.8	5.8	154	58	0.95	1500	1870	85	70	0.64	1500	2280	
S 30 1_7.1	7.1	127	58	0.79	1500	2030	71	62	0.47	1500	2400	
S 30 1_8.9	8.9	101	35	0.38	1500	2400	56	42	0.25	1500	2400	
S 30 1_10.3	10.3	87	35	0.33	1500	2400	49	42	0.22	1500	2400	
S 30 1_13.1	13.1	69	35	0.26	1500	2400	38	37	0.15	1500	2400	

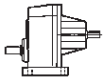
# S 40

# 125 Nm

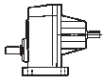
	i	n <sub>1</sub> = 2800 min <sup>-1</sup>					n <sub>1</sub> = 1400 min <sup>-1</sup>					
		n <sub>2</sub> min <sup>-1</sup>	M <sub>n2</sub> Nm	P <sub>n1</sub> kW	R <sub>n1</sub> N	R <sub>n2</sub> N	n <sub>2</sub> min <sup>-1</sup>	M <sub>n2</sub> Nm	P <sub>n1</sub> kW	R <sub>n1</sub> N	R <sub>n2</sub> N	
S 40 1_1.4	1.4	2059	48	10.6	2000	1270	1029	60	6.6	2000	1600	509
S 40 1_1.9	1.9	1514	48	7.8	2000	1450	757	60	4.9	2000	1830	
S 40 1_2.4	2.4	1172	70	8.8	1860	1490	586	90	5.6	2000	1870	
S 40 1_3.1	3.1	918	70	6.9	2000	1660	459	90	4.4	2000	2080	
S 40 1_3.8	3.8	735	70	5.5	2000	1830	367	90	3.5	2000	2290	
S 40 1_4.8	4.8	580	70	4.3	2000	2020	290	90	2.8	2000	2530	
S 40 1_6.1	6.1	461	70	3.5	2000	2220	231	90	2.2	2000	2790	
S 40 1_7.2	7.2	392	63	2.6	2000	2410	196	80	1.7	2000	3030	
S 40 1_8.6	8.6	324	48	1.7	2000	2670	162	60	1.0	2000	3370	
S 40 1_10.7	10.7	262	40	1.1	2000	2930	131	50	0.70	2000	3690	
S 40 1_12.4	12.4	226	40	1.0	2000	3100	113	50	0.60	2000	3800	



	i	n <sub>1</sub> = 900 min <sup>-1</sup>					n <sub>1</sub> = 500 min <sup>-1</sup>					
		n <sub>2</sub> min <sup>-1</sup>	M <sub>n2</sub> Nm	P <sub>n1</sub> kW	R <sub>n1</sub> N	R <sub>n2</sub> N	n <sub>2</sub> min <sup>-1</sup>	M <sub>n2</sub> Nm	P <sub>n1</sub> kW	R <sub>n1</sub> N	R <sub>n2</sub> N	
S 40 1_1.4	1.4	662	70	4.9	2000	1850	368	85	3.3	2000	2250	509
S 40 1_1.9	1.9	486	70	3.6	2000	2120	270	85	2.5	2000	2580	
S 40 1_2.4	2.4	377	105	4.2	2000	2160	209	125	2.8	2000	2650	
S 40 1_3.1	3.1	295	105	3.3	2000	2400	164	125	2.2	2000	2940	
S 40 1_3.8	3.8	236	105	2.7	2000	2650	131	125	1.8	2000	3240	
S 40 1_4.8	4.8	186	105	2.1	2000	2930	104	125	1.4	2000	3580	
S 40 1_6.1	6.1	148	105	1.7	2000	3220	82	110	1.0	2000	3800	
S 40 1_7.2	7.2	126	90	1.2	2000	3530	70	90	0.67	2000	3800	
S 40 1_8.6	8.6	104	70	0.78	2000	3800	58	85	0.53	2000	3800	
S 40 1_10.7	10.7	84	58	0.52	2000	3800	47	70	0.35	2000	3800	
S 40 1_12.4	12.4	73	58	0.45	2000	3800	40	70	0.30	2000	3800	

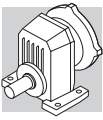



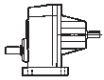

## S 50

## 200 Nm

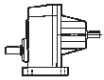
	i	n <sub>1</sub> = 2800 min <sup>-1</sup>					n <sub>1</sub> = 1400 min <sup>-1</sup>					
		n <sub>2</sub> min <sup>-1</sup>	M <sub>n2</sub> Nm	P <sub>n1</sub> kW	R <sub>n1</sub> N	R <sub>n2</sub> N	n <sub>2</sub> min <sup>-1</sup>	M <sub>n2</sub> Nm	P <sub>n1</sub> kW	R <sub>n1</sub> N	R <sub>n2</sub> N	
S 50 1_1.4	1.4	1972	85	17.9	730	1720	986	110	11.6	730	2150	511
S 50 1_1.8	1.8	1564	85	14.2	1220	1920	782	110	9.2	1370	2400	
S 50 1_2.4	2.4	1162	100	12.4	930	2110	581	130	8.1	970	2640	
S 50 1_3.0	3.0	921	110	10.8	860	2300	461	140	6.9	1020	2880	
S 50 1_3.8	3.8	729	120	9.3	640	2480	365	150	5.8	860	3130	
S 50 1_4.8	4.8	589	120	7.6	880	2710	295	150	4.7	1160	3420	
S 50 1_6.1	6.1	462	100	4.9	1980	3100	231	130	3.2	2330	3880	
S 50 1_7.4	7.4	378	100	4.0	2060	3340	189	130	2.6	2400	4190	
S 50 1_8.8	8.8	319	85	2.9	2400	3640	160	110	1.9	2400	4570	
S 50 1_10.5	10.5	268	85	2.4	2400	3880	134	110	1.6	2400	4870	
S 50 1_12.9	12.9	217	80	1.9	2400	4200	109	100	1.2	2400	5300	

	i	n <sub>1</sub> = 900 min <sup>-1</sup>					n <sub>1</sub> = 500 min <sup>-1</sup>					
		n <sub>2</sub> min <sup>-1</sup>	M <sub>n2</sub> Nm	P <sub>n1</sub> kW	R <sub>n1</sub> N	R <sub>n2</sub> N	n <sub>2</sub> min <sup>-1</sup>	M <sub>n2</sub> Nm	P <sub>n1</sub> kW	R <sub>n1</sub> N	R <sub>n2</sub> N	
S 50 1_1.4	1.4	634	125	8.5	1010	2510	352	155	5.8	1040	3040	511
S 50 1_1.8	1.8	503	125	6.7	1730	2790	279	155	4.6	1940	3380	
S 50 1_2.4	2.4	373	150	6.0	1160	3060	207	180	4.0	1530	3730	
S 50 1_3.0	3.0	296	160	5.1	1290	3350	164	200	3.5	1310	4050	
S 50 1_3.8	3.8	234	175	4.4	940	3620	130	200	2.8	1740	4460	
S 50 1_4.8	4.8	189	175	3.5	1290	3960	105	180	2.0	2400	4970	
S 50 1_6.1	6.1	149	150	2.4	2400	4500	83	150	1.3	2400	5620	
S 50 1_7.4	7.4	122	140	1.8	2400	4900	68	140	1.0	2400	6100	
S 50 1_8.8	8.8	103	125	1.4	2400	5310	57	125	0.80	2400	6580	
S 50 1_10.5	10.5	86	115	1.1	2400	5700	48	115	0.60	2400	7050	
S 50 1_12.9	12.9	70	100	0.70	2400	6210	39	100	0.40	2400	7200	

## 75 MOTOR AVAILABILITY

Please be aware that motor-gearbox combinations resulting from the following charts are purely based on geometrical compatibility.

When selecting a gearmotor, refer to procedure specified at paragraph 12 and observe particularly the condition  $S \geq f_s$ .

(E 69)

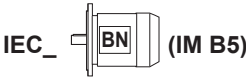
		 IEC_ <b>BN</b> (IM B5)								
		<b>BN</b>								
$P_{n1}^{(\#)}$ [kW]	2p	0.37	0.75	1.5	2.2	4	4	9.2	18.5	22
	4p	0.25	0.55	1.1	1.85	3	4	9.2	15	22
	6p	0.12	0.37	0.75	1.1	1.85	2.2	5.5	11	15
		P63	P71	P80	P90	P100	P112	P132	P160	P180
S 10 1	i =	1.4_12.3	1.4_12.3	1.4_8.9	1.4_8.9	1.4_8.9	1.4_8.9			
S 20 1		1.9_12.4	1.9_12.4	1.4_10.8	1.4_10.8	1.4_10.8	1.4_10.8			
S 30 1		2.4_13.1	2.4_13.1	1.4_13.1	1.4_13.1	1.4_13.1	1.4_13.1	1.4_4.9		
S 40 1		3.1_12.4	3.1_12.4	1.4_12.4	1.4_12.4	1.4_12.4	1.4_12.4	1.4_6.1		
S 50 1		3.8_12.9	3.8_12.9	1.4_12.9	1.4_12.9	1.4_12.9	1.4_12.9	1.4_7.4	1.4_7.4	1.4_7.4

(#)  $P_{n1}$  = maximum installable power on input P\_

(E 70)

		 M					
		M05	M1	M2	M3	M4	M5
S 10 1	i =	1.4_12.3	1.4_6.9	1.4_8.9	1.4_8.9		
S 20 1		1.9_12.4	1.9_8.5	1.4_10.8	1.4_10.8		
S 30 1			2.4_10.3	1.4_13.1	1.4_13.1	1.4_4.9	
S 40 1			3.1_12.4	1.4_12.4	1.4_12.4	1.4_6.1	
S 50 1			3.8_12.9	1.4_12.9	1.4_12.9	1.4_7.4	1.4_7.4

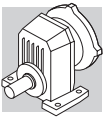

## 76 MOMENT OF INERTIA

The following charts indicate moment of inertia values  $J_r$  [kgm<sup>2</sup>] referred to the gear unit high speed shaft. A key to the symbols used follows:



Values under this icon refer to compact gear units, without motor. To obtain the overall moment of inertia for the gearmotor just add the value of the inertia for the specific compact motor, given in the relevant rating chart.



Values under this symbol refer to gearboxes with IEC motor adaptor (IEC size...).

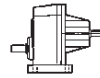

This symbol refers to gearbox values.

آتور صنعت  
ATOORSANAT



### S 10

	i	J (•10 <sup>-4</sup> ) [kgm <sup>2</sup> ]							
			63	71	80	90	100	112	
<b>S 10 1_1.4</b>	1.4	0.33	1.8	1.8	3.2	3.1	4.4	4.4	1.2
<b>S 10 1_1.9</b>	1.9	0.22	1.7	1.7	3.1	3.0	4.3	4.3	1.1
<b>S 10 1_2.5</b>	2.5	0.16	1.6	1.6	3.0	2.9	4.2	4.2	1.0
<b>S 10 1_3.2</b>	3.2	0.10	1.6	1.6	3.0	2.9	4.2	4.2	0.97
<b>S 10 1_3.9</b>	3.9	0.08	1.5	1.5	2.9	2.9	4.2	4.2	0.95
<b>S 10 1_4.7</b>	4.7	0.06	1.5	1.5	2.9	2.8	4.1	4.1	0.93
<b>S 10 1_6.1</b>	6.1	0.04	1.5	1.5	2.9	2.8	4.1	4.1	0.92
<b>S 10 1_6.9</b>	6.9	0.03	1.5	1.5	2.9	2.8	4.1	4.1	0.91
<b>S 10 1_8.9</b>	8.9	0.02	1.5	1.5	2.9	2.8	4.1	4.1	0.90
<b>S 10 1_10.3</b>	10.3	0.02	1.5	1.5	—	—	—	—	0.89
<b>S 10 1_12.3</b>	12.3	0.01	1.5	1.5	—	—	—	—	0.89

## S 20



	i	J ( $\cdot 10^{-4}$ ) [kgm <sup>2</sup> ]							
			63	71	80	90	100	112	
S 20 1_1.4	1.4	0.73	—	—	3.6	3.5	4.8	4.8	2.7
S 20 1_1.9	1.9	0.48	1.9	1.9	3.3	3.3	4.6	4.6	2.4
S 20 1_2.4	2.4	0.34	1.8	1.8	3.2	3.1	4.4	4.4	2.3
S 20 1_3.1	3.1	0.20	1.7	1.7	3.0	3.0	4.3	4.3	2.1
S 20 1_3.9	3.9	0.14	1.6	1.6	3.0	2.9	4.2	4.2	2.1
S 20 1_4.8	4.8	0.12	1.6	1.6	3.0	2.9	4.2	4.2	2.0
S 20 1_5.8	5.8	0.08	1.6	1.5	2.9	2.9	4.2	4.2	2.0
S 20 1_7.2	7.2	0.06	1.5	1.5	2.9	2.8	4.1	4.1	2.0
S 20 1_8.5	8.5	0.05	1.5	1.5	2.9	2.8	4.1	4.1	2.0
S 20 1_10.8	10.8	0.03	1.5	1.5	2.9	2.8	4.1	4.1	1.9
S 20 1_12.4	12.4	0.02	1.5	1.5	—	—	—	—	1.9

## S 30

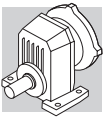

	i	J ( $\cdot 10^{-4}$ ) [kgm <sup>2</sup> ]								
			63	71	80	90	100	112		132
S 30 1_1.4	1.4	1.5	—	—	4.3	4.3	5.6	5.6	18	3.8
S 30 1_1.8	1.8	1.1	—	—	3.9	3.8	5.1	5.1	18	3.4
S 30 1_2.4	2.4	0.59	2.1	2.0	3.4	3.4	4.7	4.7	17	2.9
S 30 1_3.1	3.1	0.45	1.9	1.9	3.3	3.2	4.5	4.5	17	2.8
S 30 1_3.9	3.9	0.33	1.8	1.8	3.2	3.1	4.4	4.4	17	2.7
S 30 1_4.9	4.9	0.24	1.7	1.7	3.1	3.0	4.3	4.3	17	2.6
S 30 1_5.8	5.8	0.19	1.7	1.7	3.0	3.0	4.3	4.3	—	2.6
S 30 1_7.1	7.1	0.14	1.6	1.6	3.0	2.9	4.2	4.2	—	2.5
S 30 1_8.9	8.9	0.10	1.6	1.6	2.9	2.9	4.2	4.2	—	2.5
S 30 1_10.3	10.3	0.08	1.5	1.5	2.9	2.9	4.2	4.2	—	2.4
S 30 1_13.1	13.1	0.05	1.5	1.5	2.9	2.8	4.1	4.1	—	2.4



## S 40

	i	J ( $\cdot 10^{-4}$ ) [kgm <sup>2</sup> ]								
			63	71	80	90	100	112	132	
S 40 1_1.4	1.4	3.7	—	—	6.5	6.5	7.8	7.8	23	14
S 40 1_1.9	1.9	2.4	—	—	5.2	5.2	6.5	6.5	21	13
S 40 1_2.4	2.4	1.6	—	—	4.4	4.4	5.7	5.7	21	12
S 40 1_3.1	3.1	1.1	2.6	2.6	4.0	3.9	5.2	5.2	20	12
S 40 1_3.8	3.8	0.82	2.3	2.3	3.7	3.6	4.9	4.9	18	11
S 40 1_4.8	4.8	0.50	2.0	2.0	3.3	3.3	4.6	4.6	18	11
S 40 1_6.1	6.1	0.39	1.8	1.8	3.2	3.2	4.5	4.5	18	11
S 40 1_7.2	7.2	0.30	1.8	1.8	3.1	3.1	4.4	4.4	—	11
S 40 1_8.6	8.6	0.22	1.7	1.7	3.1	3.0	4.3	4.3	—	11
S 40 1_10.7	10.7	0.15	1.6	1.6	3.0	2.9	4.2	4.2	—	11
S 40 1_12.4	12.4	0.12	1.6	1.6	3.0	2.8	4.2	4.2	—	11

## S 50

	i	J ( $\cdot 10^{-4}$ ) [kgm <sup>2</sup> ]										
			63	71	80	90	100	112	132	160	180	
S 50 1_1.4	1.4	8.2	—	—	11	11	12	12	27	86	84	19
S 50 1_1.8	1.8	5.9	—	—	8.8	8.7	10	10	25	84	82	16
S 50 1_2.4	2.4	3.9	—	—	6.8	6.7	8.0	8.0	23	82	80	14
S 50 1_3.0	3.0	2.7	—	—	5.5	5.5	6.8	6.8	22	81	79	13
S 50 1_3.8	3.8	1.9	3.3	3.3	4.7	4.6	5.9	5.9	21	80	78	12
S 50 1_4.8	4.8	1.4	2.8	2.8	4.2	4.1	5.4	5.4	21	79	77	12
S 50 1_6.1	6.1	0.89	2.4	2.4	3.7	3.7	5.0	5.0	21	79	77	11
S 50 1_7.4	7.4	0.63	2.1	2.1	3.5	3.4	4.7	4.7	20	79	77	11
S 50 1_8.8	8.8	0.50	2.0	2.0	3.4	3.3	4.6	4.6	—	—	—	11
S 50 1_10.5	10.5	0.36	1.8	1.8	3.2	3.1	4.4	4.4	—	—	—	11
S 50 1_12.9	12.9	0.25	1.7	1.7	3.1	3.0	4.3	4.3	—	—	—	11

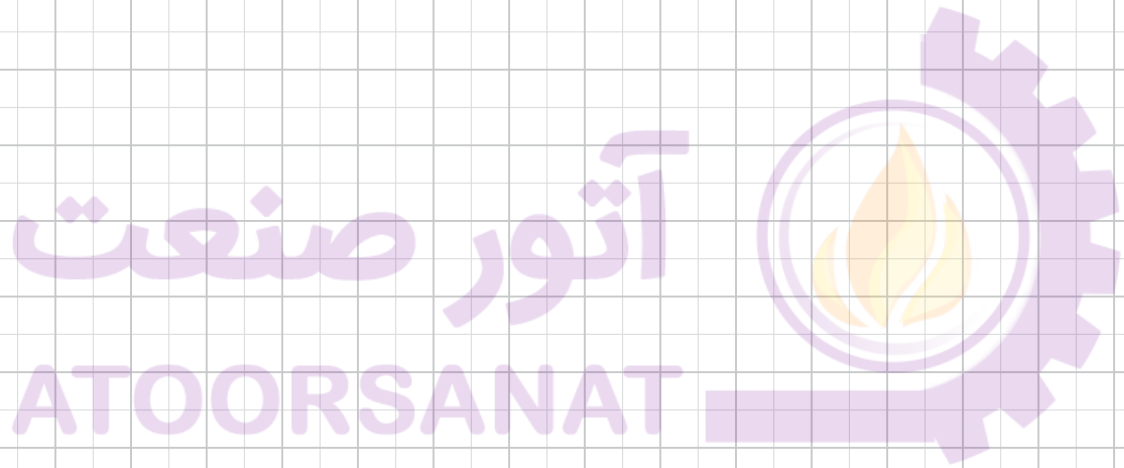

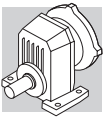

77 DIMENSIONS

S 10...M

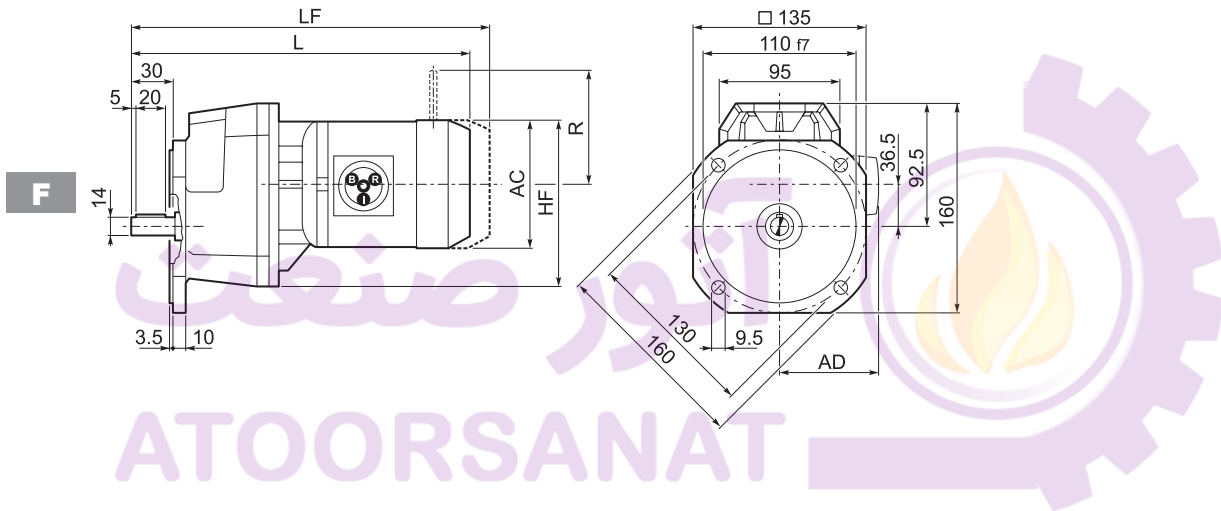
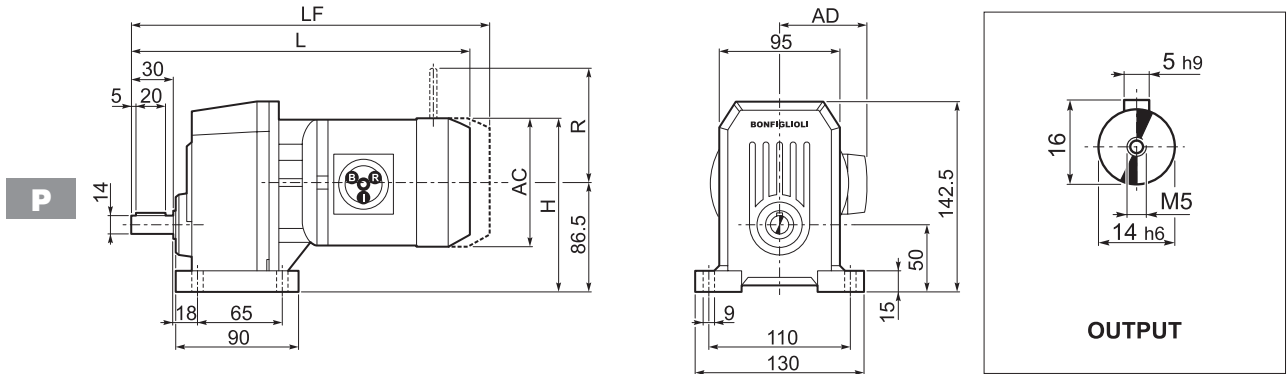

S	S	M	AC	H	HF	L	AD	Kg	M...FD M...FA		M...FD		M...FA	
									LF	Kg	R	AD	R	AD
S 10 1	S05	M05	121	147	143	315	95	8	381	11	96	122	116	95
S 10 1	S1	M1	137	155	151	344	102	10	405	13	103	135	124	108
S 10 1	S2	M2S	156	164	160	367	111	13	443	17	129	146	134	119
S 10 1	S3	M3S	195	184	180	416	135	19	512	24	160	158	160	142
S 10 1	S3	M3L	195	184	180	448	135	21	539	26	160	158	160	142

## S 10...P (IEC)

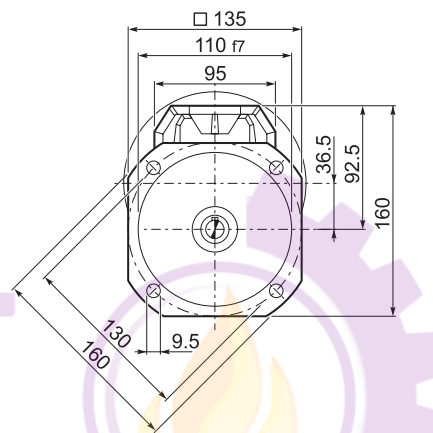
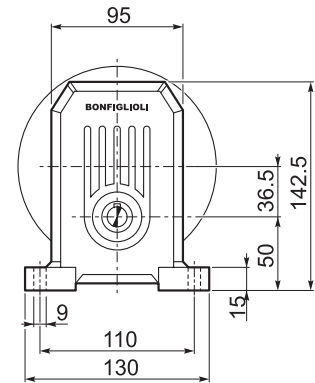
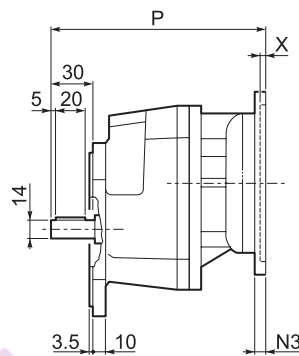
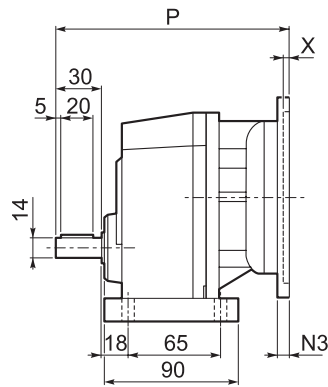
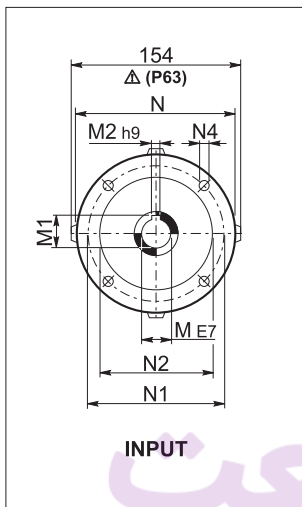
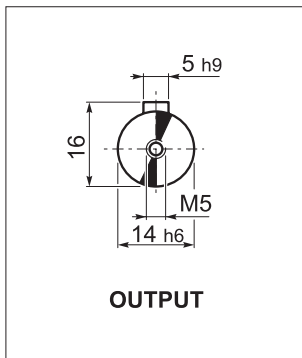

		M	M1	M2	N	N1	N2	N3	N4	P	X	kg
S 10 1	P63	11	12.8	4	140	115	95	—	M8x10	189	4	5
S 10 1	P71	14	16.3	5	160	130	110	—	M8x10	189	4.5	5
S 10 1	P80	19	21.8	6	200	165	130	—	M10x14.5	208	4	6
S 10 1	P90	24	27.3	8	200	165	130	—	M10x14.5	208	4	6
S 10 1	P100	28	31.3	8	250	215	180	—	M12x16	218	4.5	10
S 10 1	P112	28	31.3	8	250	215	180	—	M12x16	218	4.5	10

## S 10...HS

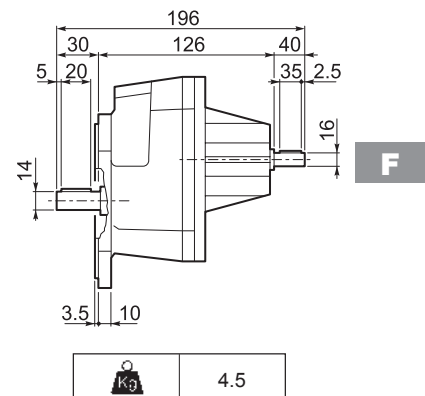
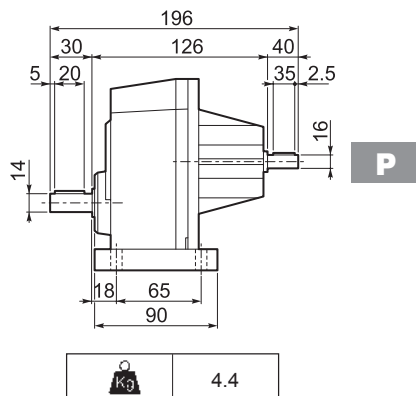
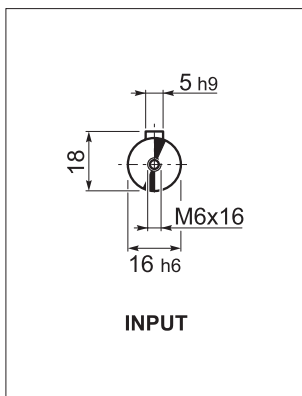



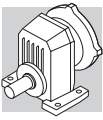

## S 20...M

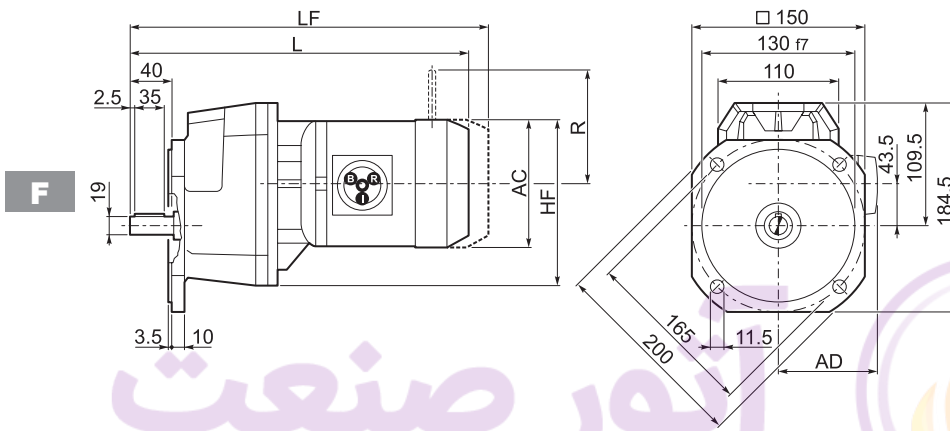
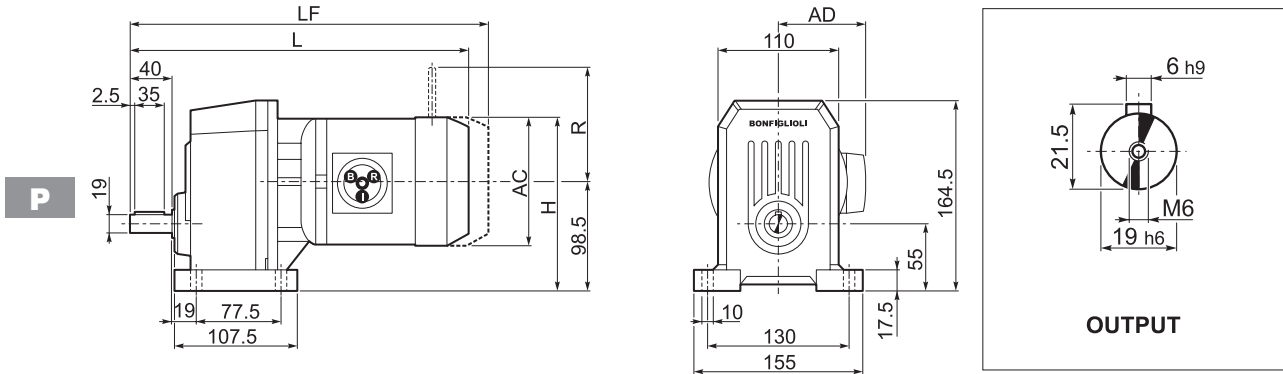

⌋	⌋	□	AC	H	HF	L	AD	Kg	M...FD M...FA	Kg	M...FD		M...FA	
									LF		R	AD	R	AD
S 20 1	S05	M05	121	159	153	333.5	95	10	399.5	12	96	122	116	95
S 20 1	S1	M1	137	167	161	362.5	102	12	423.5	14	103	135	124	108
S 20 1	S2	M2S	156	176	170	385.5	111	16	461.5	19	129	146	134	119
S 20 1	S3	M3S	195	196	190	434.5	135	20	530.5	25	160	158	160	142
S 20 1	S3	M3L	195	196	190	466.5	135	26	557.5	31	160	158	160	142

## S 20...P(IEC)

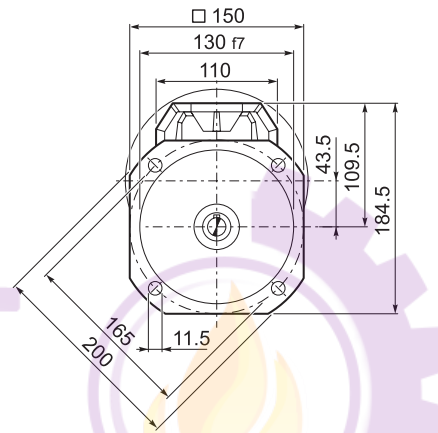
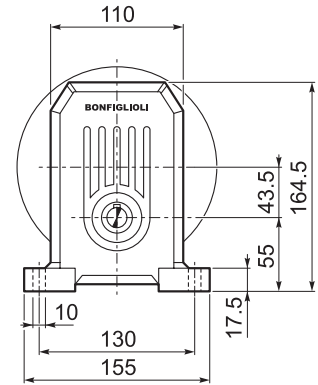
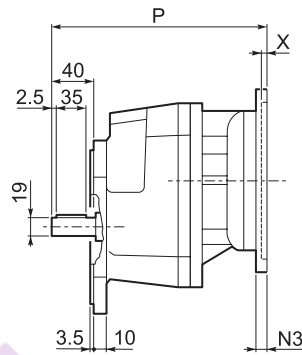
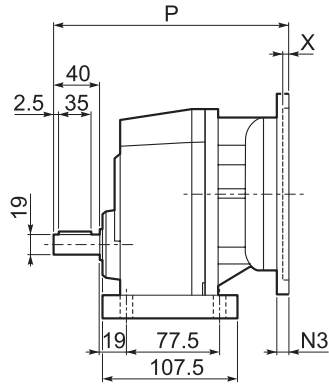
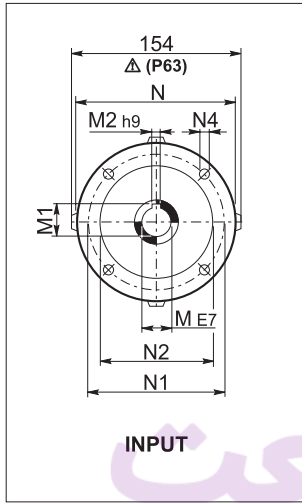
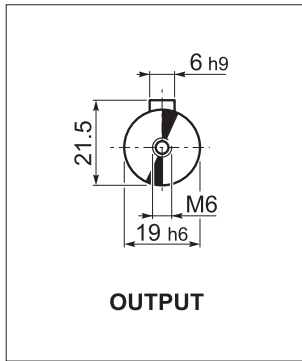

		M	M1	M2	N	N1	N2	N3	N4	P	X	Kg
S 20 1	P63	11	12.8	4	140	115	95	—	M8x10	207	4	6
S 20 1	P71	14	16.3	5	160	130	110	—	M8x10	207	4.5	6
S 20 1	P80	19	21.8	6	200	165	130	—	M10x14.5	227	4	7
S 20 1	P90	24	27.3	8	200	165	130	—	M10x14.5	227	4	7
S 20 1	P100	28	31.3	8	250	215	180	—	M12x16	237	4.5	11
S 20 1	P112	28	31.3	8	250	215	180	—	M12x16	237	4.5	11

## S 20...HS

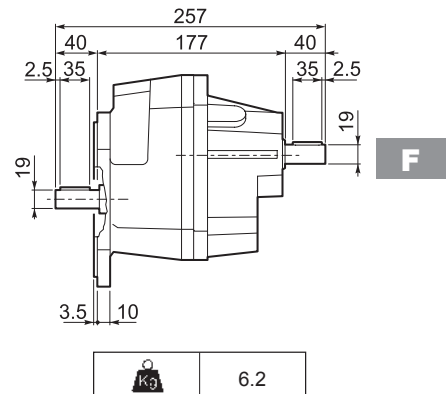
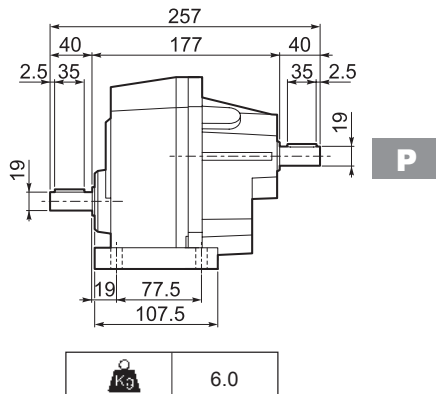
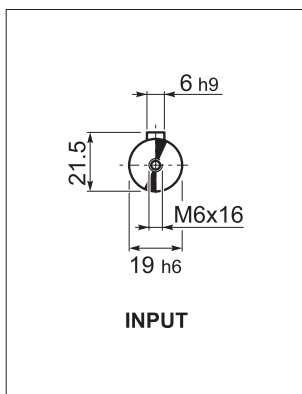

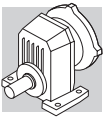

## S 30...M

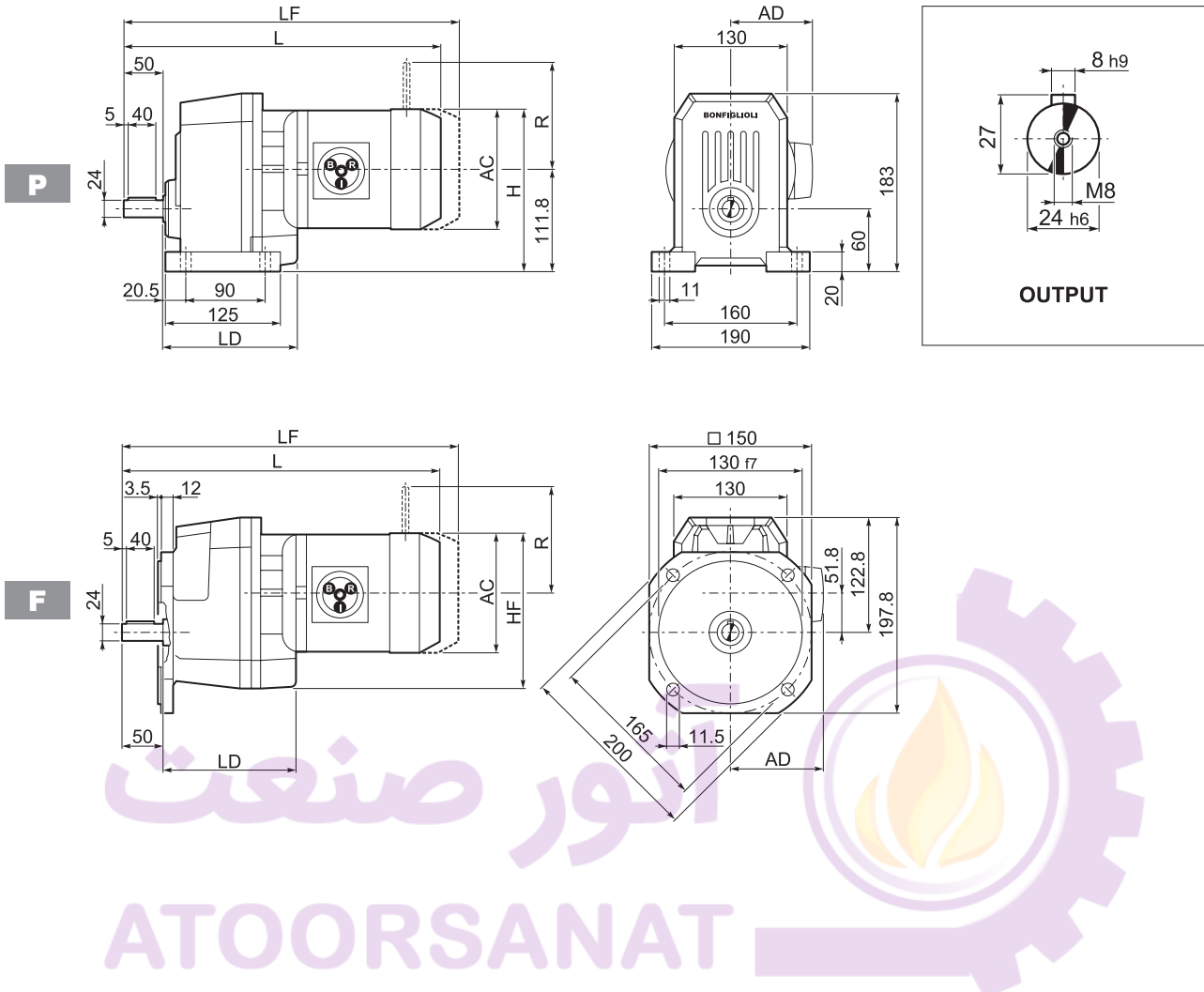

S	S	M	AC	H	HF	L	LD	AD	Kg	M...FD M...FA		M...FD		M...FA	
										LF	Kg	R	AD	R	AD
S 30 1	S1	M1	137	180	177	387.5	140.5	102	14	448.5	16	103	135	124	108
S 30 1	S2	M2S	156	190	186	410.5	152.5	111	18	486.5	21	129	146	134	119
S 30 1	S3	M3S	195	209	206	459.5	162.5	135	23	555.5	28	160	158	160	142
S 30 1	S3	M3L	195	209	206	491.5	162.5	135	32	582.5	37	160	158	160	142
S 30 1	S4	M4	258	240.8	237	599.5	—	193	71	708.5	87	226	210	217	193
S 30 1	S4	M4LC	258	240.8	237	634.5	—	193	79	733.5	95	226	210	217	193

## S 30...P(IEC)

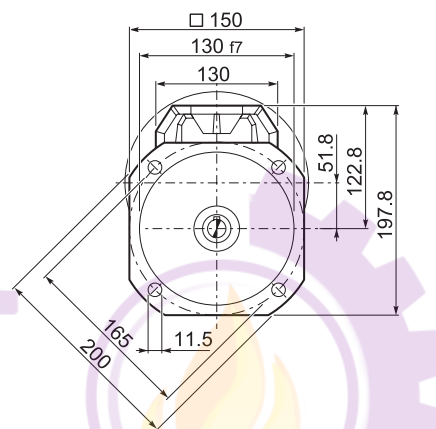
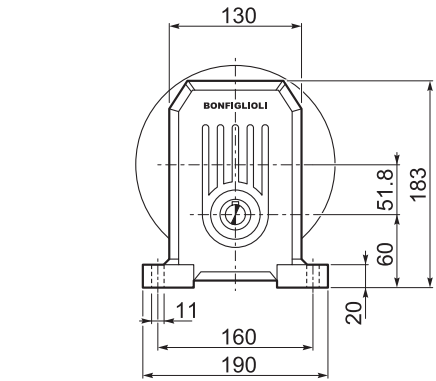
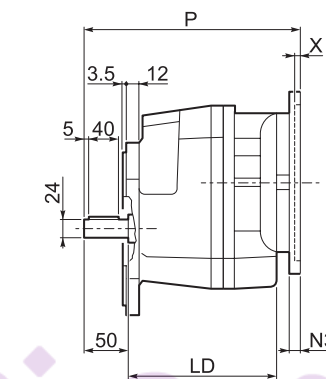
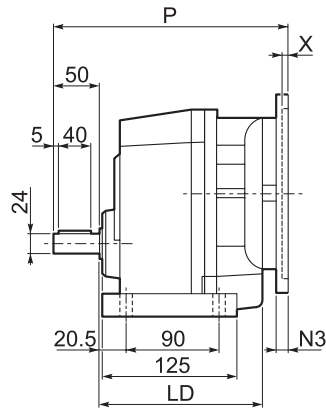
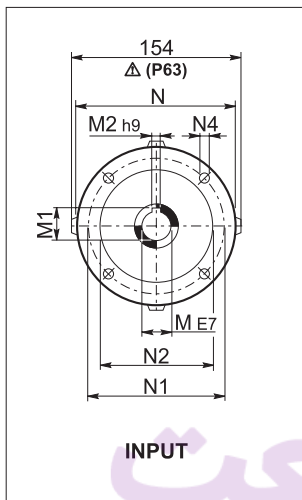
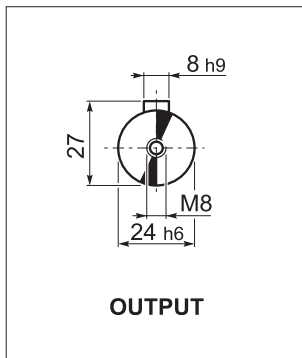

		LD	M	M1	M2	N	N1	N2	N3	N4	P	X	kg
S 30 1	P63	152.5	11	12.8	4	140	115	95	—	M8x10	232	4	8
S 30 1	P71	152.5	14	16.3	5	160	130	110	—	M8x10	232	4.5	8
S 30 1	P80	162.5	19	21.8	6	200	165	130	—	M10x14.5	252	4	9
S 30 1	P90	162.5	24	27.3	8	200	165	130	—	M10x14.5	252	4	9
S 30 1	P100	162.5	28	31.3	8	250	215	180	—	M12x16	262	4.5	13
S 30 1	P112	162.5	28	31.3	8	250	215	180	—	M12x16	262	4.5	13
S 30 1	P132	—	38	41.3	10	300	265	230	16	14	298.5	5	21

## S 30...HS

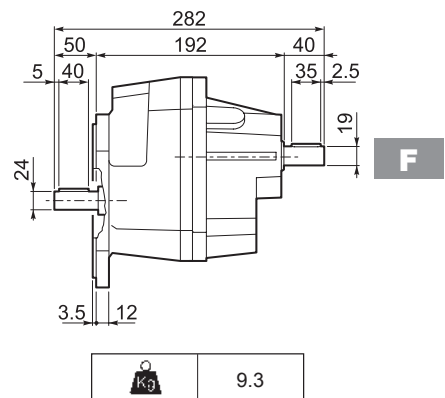
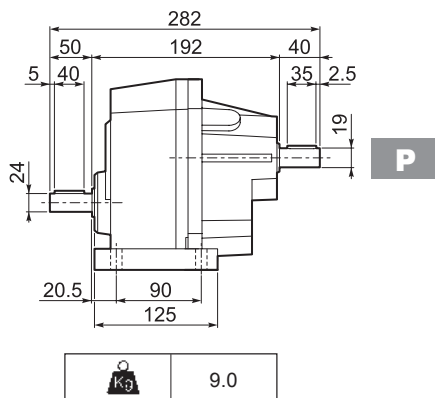
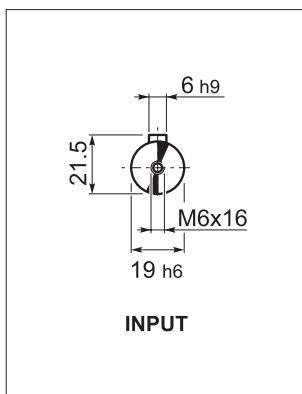

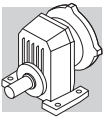

## S 40...M

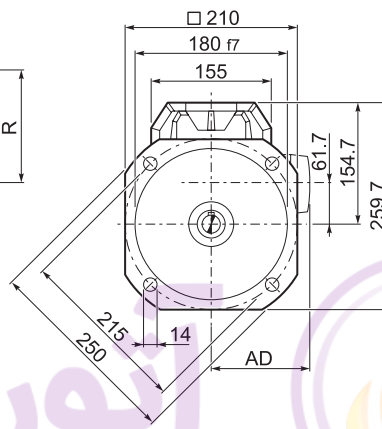
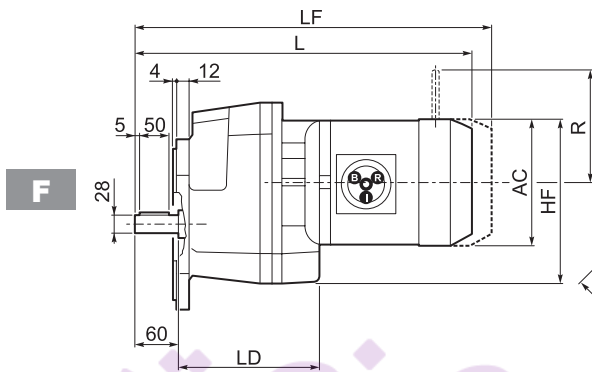
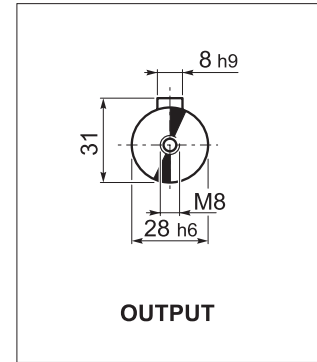
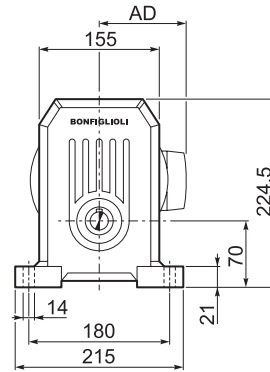
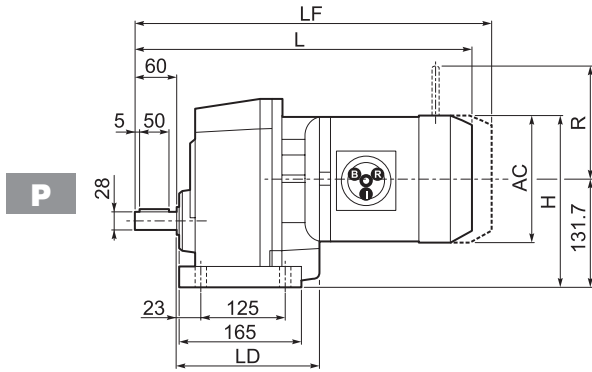

آتور صنعت  
ATOORSANAT

S	S	M	AC	H	HF	L	LD	AD	Kg	M...FD M...FA		M...FD		M...FA	
										LF	Kg	R	AD	R	AD
S 40 1	S1	M1	137	200	197	429.5	168	102	28	490.5	31	103	135	124	108
S 40 1	S2	M2S	156	210	206	452.5	183.5	111	34	528.5	37	129	146	134	119
S 40 1	S3	M3S	195	229	226	501.5	199.5	135	39	597.5	44	160	158	160	142
S 40 1	S3	M3L	195	229	226	533.5	199.5	135	48	624.5	53	160	158	160	142
S 40 1	S4	M4	258	261	257	641.5	—	193	74	750.5	86	226	210	217	193
S 40 1	S4	M4LC	258	261	257	676.5	—	193	90	775.5	106	226	210	217	193

## S 40...P(IEC)

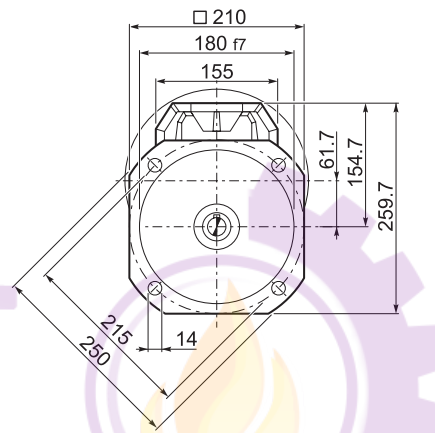
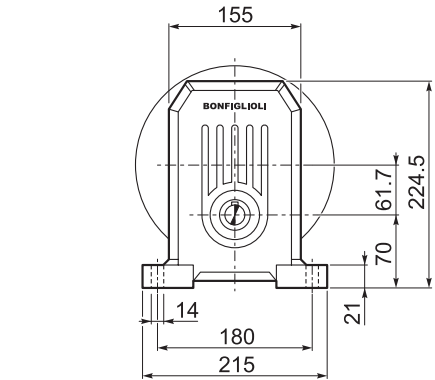
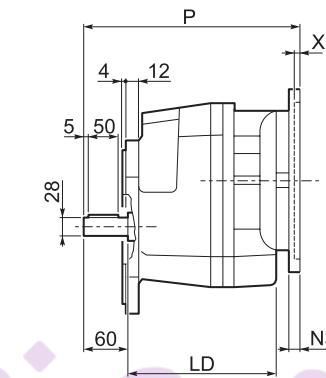
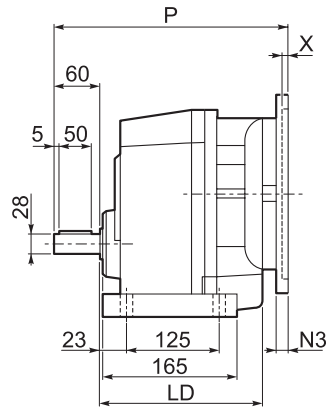
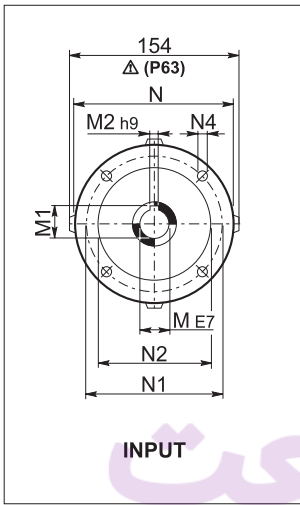
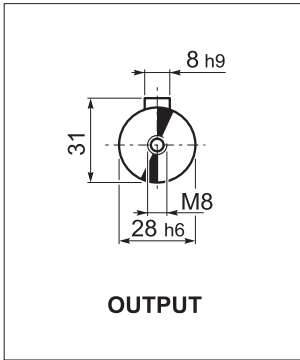

		LD	M	M1	M2	N	N1	N2	N3	N4	P	X	kg
S 40 1	P63	183.5	11	12.8	4	140	115	95	—	M8x10	274	4	25
S 40 1	P71	183.5	14	16.3	5	160	130	110	—	M8x10	274	4.5	26
S 40 1	P80	199.5	19	21.8	6	200	165	130	—	M10x14.5	294	4	26
S 40 1	P90	199.5	24	27.3	8	200	165	130	—	M10x14.5	294	4	30
S 40 1	P100	—	28	31.3	8	250	215	180	—	M12x16	304	4.5	30
S 40 1	P112	—	28	31.3	8	250	215	180	—	M12x16	304	4.5	30
S 40 1	P132	—	38	41.3	10	300	265	230	16	14	340	5	32

## S 40...HS

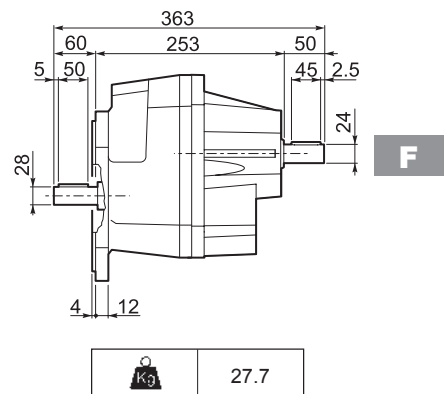
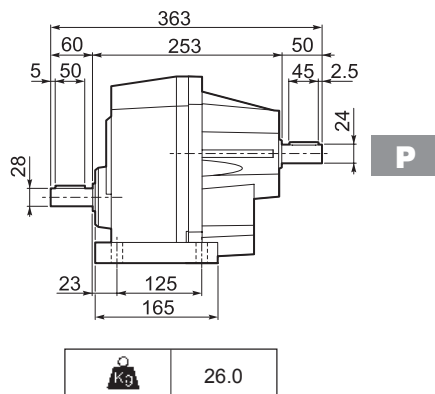
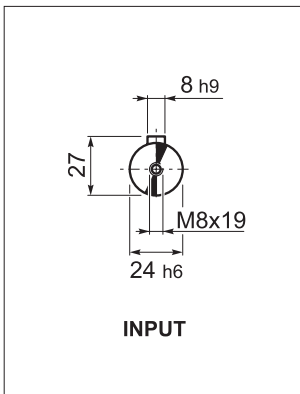

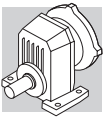

## S 50...M

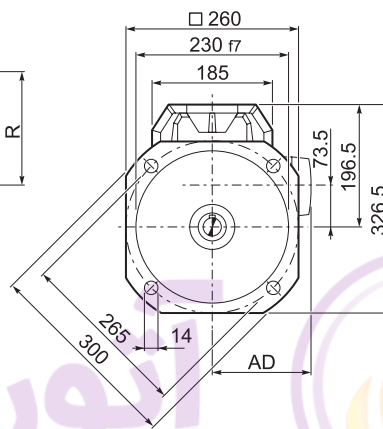
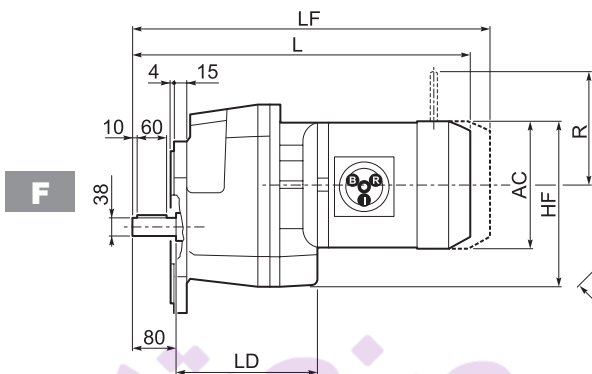
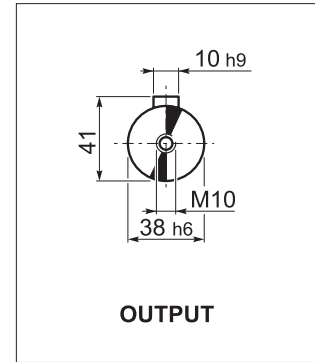
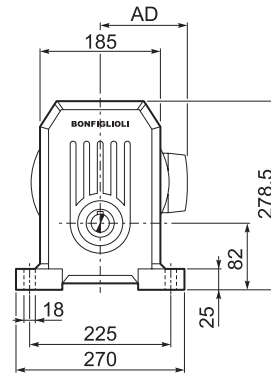
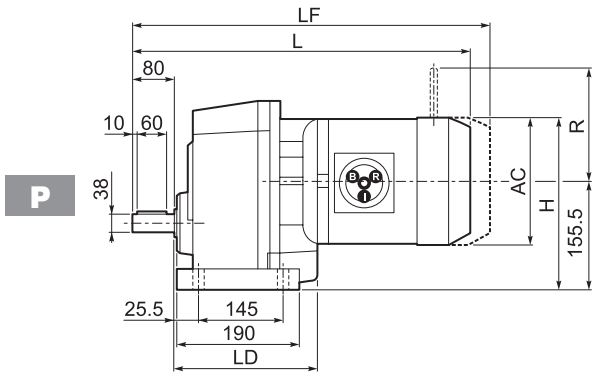

آتور صنعت  
ATOORSANAT

⎓	⏏	□	AC	H	HF	L	LD	AD	Kg	M...FD M...FA		M...FD		M...FA	
										LF	Kg	R	AD	R	AD
S 50 1	S1	M1	137	225	222	469	—	102	40	530	42	103	135	124	108
S 50 1	S2	M2S	156	233	230	492.5	204.5	111	44	568.5	47	129	146	134	119
S 50 1	S3	M3S	195	253	250	541.5	219.5	135	51	637.5	56	160	158	160	142
S 50 1	S3	M3L	195	253	250	573.5	219.5	135	60	664.5	65	160	158	160	142
S 50 1	S4	M4	258	284	281	681.5	204.5	193	86	790.5	98	226	210	217	193
S 50 1	S4	M4LC	258	284	281	716.5	204.5	193	94	815.5	106	226	210	217	193
S 50 1	S5	M5S	310	310.5	307	768	—	245	114	908	138	266	245	247	245
S 50 1	S5	M5L	310	310.5	307	812	—	245	130	952	154	266	245	247	245

## S 50...P(IEC)

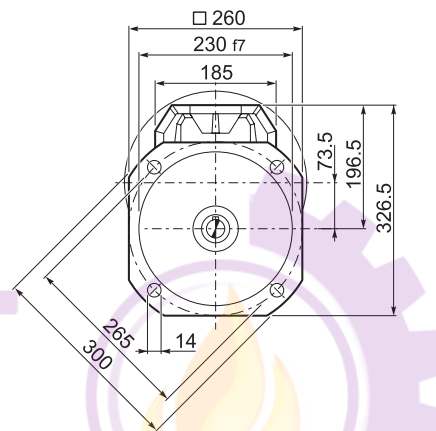
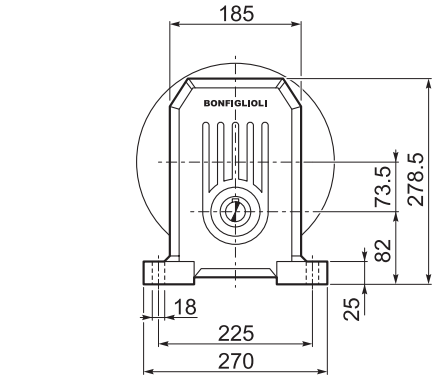
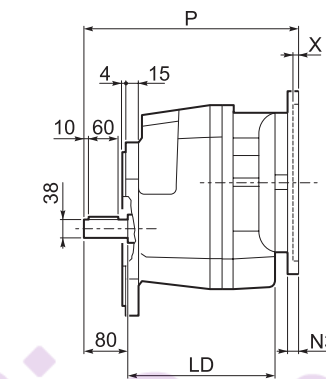
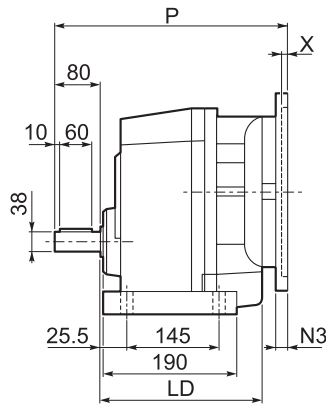
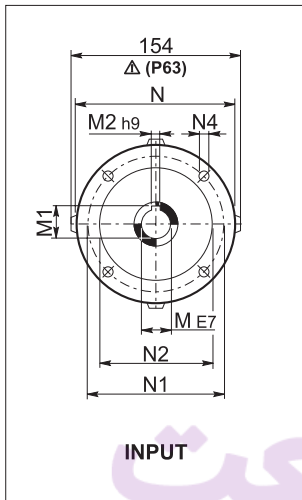
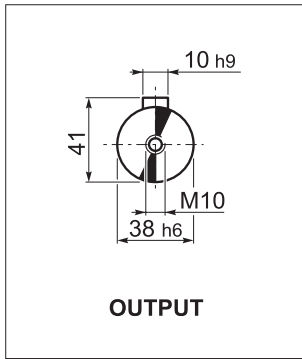

		LD	M	M1	M2	N	N1	N2	N3	N4	P	X	kg
S 50 1	P63	204.5	11	12.8	4	140	115	95	—	M8x10	314	4	35
S 50 1	P71	204.5	14	12.8	4	160	130	110	—	M8x10	314	4.5	35
S 50 1	P80	219.5	19	16.3	5	200	165	130	—	M10x14.5	314	4	37
S 50 1	P90	219.5	24	21.8	6	200	165	130	—	M10x14.5	334	4	37
S 50 1	P100	204.5	28	27.3	8	250	215	180	—	M12x16	344	4.5	41
S 50 1	P112	204.5	28	31.3	8	250	215	180	—	M12x16	344	4.5	41
S 50 1	P132	204.5	38	41.3	10	300	265	230	16	14	380	5	44
S 50 1	P160	—	42	45.3	12	350	300	250	23	18	431	5.5	48
S 50 1	P180	—	48	51.8	14	350	300	250	23	18	431	5.5	48

## S 50...HS

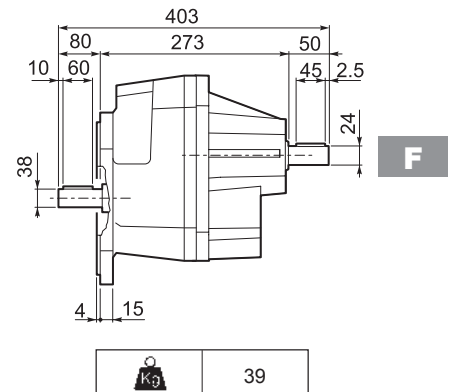
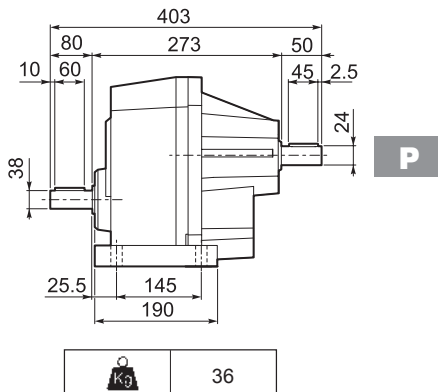
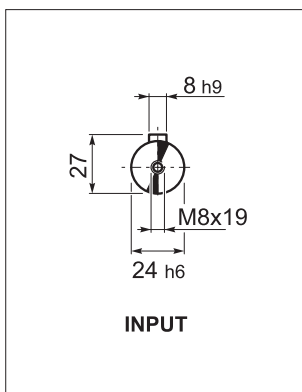



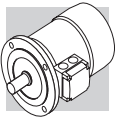

## ELECTRIC MOTORS

### M1 SYMBOLS AND UNITS OF MEASUREMENT

Symbols	Units of Measure	Description	Symbols	Units of Measure	Description
$\cos\phi$	–	Power factor	$n$	[min <sup>-1</sup> ]	Rated speed
$\eta$	–	Efficiency	$P_B$	[W]	Power drawn by the brake at 20°C
$f_m$	–	Power adjusting factor	$P_n$	[kW]	Motor rated power
$I$	–	Cyclic duration factor	$P_r$	[kW]	Required power
$I_N$	[A]	Rated current	$t_1$	[ms]	Brake response time with one-way rectifier
$I_s$	[A]	Locked rotor current	$t_{1s}$	[ms]	Brake response time with electronic-controlled rectifier
$J_C$	[Kgm <sup>2</sup> ]	Load moment of inertia	$t_2$	[ms]	Brake reaction time with a.c. disconnect
$J_M$	[Kgm <sup>2</sup> ]	Moment of inertia	$t_{2c}$	[ms]	Brake reaction time with a.c. and d.c. disconnect
$K_C$	–	Torque factor	$t_a$	[°C]	Ambient temperature
$K_d$	–	Load factor	$t_f$	[min]	Work time at constant load
$K_J$	–	Inertia factor	$t_r$	[min]	Rest time
$M_A$	[Nm]	Mean breakaway torque	$W$	[J]	Braking work between service interval
$M_B$	[Nm]	Brake torque	$W_{max}$	[J]	Maximum brake work for each braking
$M_N$	[Nm]	Rated torque	$Z$	[1/h]	Permissible starting frequency, loaded
$M_L$	[Nm]	Counter-torque during acceleration	$Z_0$	[1/h]	Max. permissible unloaded starting frequency (I = 50%)
$M_S$	[Nm]	Starting torque			

## M2 GENERAL CHARACTERISTICS

### M2.1 Production range

The asynchronous three-phase electric motors of BONFIGLIOLI RIDUTTORI's production, are available in basic designs IMB5 and derived versions, with the following polarities: 2, 4, 6, 2/4, 2/6, 2/8, 2/12.

The technical characteristics of compact motors, M type, are also supplied in this manual.

### M2.2 Standards

The motors described in this catalogue are manufactured to the applicable standards shown in the following table.

(F 1)

Title	CEI	IEC
General requirements for rotating electrical machines	CEI EN 60034-1	IEC 60034-1
Terminal markings and direction of rotation of rotating machines	CEI 2-8	IEC 60034-8
Methods of cooling for electrical machines	CEI EN 60034-6	IEC 60034-6
Dimensions and output ratings for rotating electrical machines	EN 50347	IEC 60072
Classification of degree of protection provided by enclosures for rotating machines	CEI EN 60034-5	IEC 60034-5
Noise limits	CEI EN 60034-9	IEC 60034-9
Classification of type of construction and mounting arrangements	CEI EN 60034-7	IEC 60034-7
Rated voltage for low voltage mains power	CEI 8-6	IEC 60038
Vibration level of electric machines	CEI EN 60034-14	IEC 60034-14

The motors also comply with foreign standards adapted to IEC 60034-1 as shown here below.

(F 2)

DIN VDE 0530	Germany
BS5000 / BS4999	Great Britain
AS 1359	Australia
NBNC 51 - 101	Belgium
NEK - IEC 34	Norway
NF C 51	France
OEVE M 10	Austria
SEV 3009	Switzerland
NEN 3173	Netherlands
SS 426 01 01	Sweden

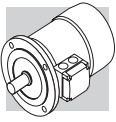

## M2.3 Motors for USA and Canada

### CUS

BN motors are available in NEMA Design C configuration (concerning electrical characteristics), in compliance with CSA (Canadian standard) C22.2 No. 100 and UL (Underwriters Laboratory) UL 1004-1. By specifying the option CUS the name plate is marked with both symbols shown here below.



The CUS option does not apply to servo-ventilated motors. US power mains voltages and the corresponding rated voltages to be specified for the motor are indicated in the following table:

(F 3)

Frequency	Mains voltage	V <sub>mot</sub>
60 Hz	208 V	<b>200 V</b>
	240 V	<b>230 V</b>
	480 V	<b>460 V</b>
	600 V	<b>575 V</b>

CUS option is applicable onto 50 Hz operating motors as well.

Motors with voltage in ratio 2 (e.g. 230/460-60; 220/440-60) feature, as standard, a 9-stud terminal board. For some executions, as well as for 575V-60Hz tions, as well as for 575V-60Hz supply, the nominal rating is coincident with the correspondent 50Hz rating.

For DC brake motors type BN/M\_FD, the rectifier is connected to a single-phase 230 VAC supply voltage in the motor terminal box.

**Brake power supply** for brake motors is as follows:

(F 4)

BN_FD M_FD	BN_FA M_FA	Specify
Wired to terminal box 1~230V a.c.	Separate power supply 230V Δ	230SA
	Separate power supply 460V Y	460SA

## M2.4 China Compulsory Certification

### CCC

Electric motors destined for sale in the People's Republic of China have to be certified under the CCC (China Compulsory Certification) system. BN motors of up to 7 Nm in rated torque are available with CCC certification and a special nameplate bearing the mark shown below:



CCC option is not currently available for servo - ventilated motors.

## M2.5 Directives 2006/95/EC (LVD) and 2004/108/EC (EMC)

BN and M motors meet the requirements of Directives 2006/95/EC (Low Voltage Directive) and 2004/108/EC (Electromagnetic Compatibility Directive) and their name plates bear the CE mark. As for the EMC Directive, construction is in accordance with standards CEI EN 60034-1, EN 61000-6-2, EN 61000-6-4.

Motors with FD brakes, when fitted with the suitable capacitive filter at rectifier input (option **CF**), meet the emission limits required by Standard EN 61000-6-3:2007 "Electromagnetic compatibility - Generic Emission Standard - Part 6-3 Residential, commercial and light industrial environment". Motors also meet the requirements of standard CEI EN 60204-1 "Electrical equipment of machines". The responsibility for final product safety and compliance with applicable directives rests with the manufacturer or the assembler who incorporate the motors as component parts.

## M2.6 Tolerances

As per the Norms applicable the tolerances here below apply to the following quantities.

(F 5)

-0.15 (1 - $\eta$ ) $P \leq 50kW$	Efficiency
$-(1 - \cos\phi)/6$ min 0.02 max 0.07	Power factor
$\pm 20\%$ *	Slip
+20%	Locked rotor current
-15% +25%	Locked rotor torque
-10%	Max. torque

\*  $\pm 30\%$  for motors with  $P_n < 1 kW$

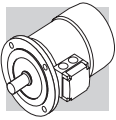

### M3 MECHANICAL FEATURES

#### M3.1 Versions

EC-normalised BN motors are available in the design versions indicated in table (F6) as per Standards CEI EN 60034-14.

Mounting versions are:

**IM B5** (basic)

IM V1, IM V3 (derived)

IM B5 design motors can be installed in positions IM V1 and IM V3; in such cases, the basic design IM B5 is indicated on the motor name plate.

In design versions with a vertically located motor and shaft downwards, it is recommended to request the drip cover (always necessary for brake motors). This facility, included in the option list should be specified when ordering as it does not come as a standard device

(F 6)

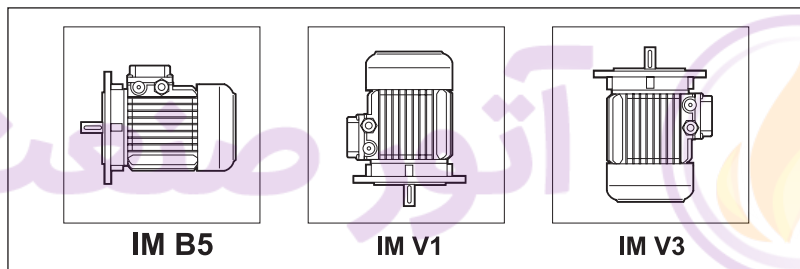

Flange output motors are also available with reduced coupling dimensions, as indicated in the table below - executions **B5R**. Their use in combination with gearboxes must be however coherent with the maximum installable power on gearboxes themselves (see chapters "Motors availability"). In case this condition is not met need to contact the Technical Service for the checking of the combination.

(F 7)

	BN 71	BN 80	BN 90	BN 100	BN 112	BN 132
	DxE - Ø					
<b>B5R</b> <sup>(1)</sup>	11x23 - 140	14x30 - 160	19x40 - 200	24x50 - 200	24x50 - 200	28x60 - 250

(1) flange with through holes







### M3.2 Degree of protection

#### IP..

The following chart provides an overview of the degrees of protection available.

In addition to the degree of protection specified when ordering, motors to be installed outdoors require protection against direct sunlight and also – when they are to be installed vertically down – a drip cover to prevent the ingress of water and solid particles (option **RC**).

(F 8)

		IP 54	IP 55	IP 56
<b>BN</b>	<b>M</b>		standard	
<b>BN_FD</b> <b>BN_FA</b>	<b>M_FD</b> <b>M_FA</b>	standard		

### M3.3 Cooling

The motors are externally ventilated (IC 411 to CEI EN 60034-6) and are equipped with a plastic fan working in both directions. The motors must be installed allowing sufficient space between fan cowl and the nearest wall to ensure free air intake and allow access for maintenance purposes on motor and brake, if supplied.

Independent, forced air ventilation (IC 416) can be supplied on request (option U1).

This solution enables to increase the motor duty factor when driven by an inverter and operating at reduced speed.

### M3.4 Direction of rotation

Rotation is possible in both directions. If terminals U1, V1, and W1 are connected to line phases L1, L2 and L3, clockwise rotation (looking from drive end) is obtained. For counterclockwise rotation, switch two phases.

### M3.5 Noise

Noise levels, measured using the method prescribed by ISO 1680 Standards, are within the maximum levels specified by Standards CEI EN 60034-9.

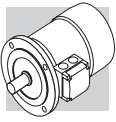

### M3.6 Vibrations and balancing

Rotor shafts are balanced with half key fitted and fall within the vibration class N, as per Standard CEI EN 60034-14.

If a further reduced noise level is required improved balancing care required improved balancing can be optionally requested (class B).

Table below shows the value for the vibration velocity for standard (A) and improved (B) balancing.

(F 9)

Vibration class	Angular velocity  n [min <sup>-1</sup> ]	Limits of the vibration velocity
		[mm/s] <b>BN 56 ≤ H ≤ BN 200</b> <b>M05 ≤ H ≤ M5</b>
<b>A</b>	600 < n < 3600	1.6
<b>B</b>	600 < n < 3600	0.70

Values refer to measures with freely suspended motor in unloaded conditions.

### M3.7 Terminal box

Terminal board features 6 studs for eyelet terminal connection (9 studs execution for US voltage “Dual Voltage”).

A ground terminal is also supplied for earthing of the equipment.



Terminals number and type are shown in the following table.

For brake power supply, please read par. M6 (brake FD), M7 (brake FA).

Brakemotors house the a.c./d.c. rectifier (factory pre-wired) inside the terminal box.

Wiring instructions are provided either in the box or in the user manual.



(F 10)

		No. of terminals	Terminal threads	Wire max cross section area mm <sup>2</sup>
<b>BN 56 ... BN 71</b>	<b>M05, M1</b>	6	M4	2.5
<b>BN 80, BN 90</b>	<b>M2</b>	6	M4	2.5
<b>BN 100 ... BN 112</b>	<b>M3</b>	6	M5	6
<b>BN 132 ... BN 160MR</b>	<b>M4</b>	6	M5	6
<b>BN 160M ... BN 180M</b>	<b>M5</b>	6	M6	16
<b>BN 180L ... BN 200L</b>	–	6	M8	25
<b>BN 63 ... BN 160MR</b>	<b>M05 ... M4</b>	9	M4	6
<b>BN 160M ... BN 200L</b>	<b>M5</b>	9	M6	16

### M3.8 Cable entry

The holes used to bring cables to terminal boxes use metric threads in accordance with standard EN 50262 as indicated in the table here after.

(F 11)

		Cable entry	Max. cable diameter allowed [mm]
<b>BN 63</b>	<b>M05</b>	2 x M20 x 1.5	13
<b>BN 71</b>	<b>M1</b>	2 x M25 x 1.5	17
<b>BN 80 - BN 90</b>	<b>M2</b>	2 x M25 x 1.5	17
<b>BN 100</b>	<b>M3</b>	2 x M32 x 1.5	21
		2 x M25 x 1.5	17
<b>BN 112</b>	—	2 x M32 x 1.5	21
		2 x M25 x 1.5	17
<b>BN 132...BN 160MR</b>	<b>M4</b>	4 x M32 x 1.5	21
<b>BN 160M...BN 200L</b>	<b>M5</b>	2 x M40 x 1.5	28

### M3.9 Bearings

Life lubricated preloaded radial ball bearings are used, types are shown in the chart here under. Calculated endurance lifetime  $L_{10h}$ , as per ISO 281, in unloaded condition, exceeds 40000 hrs.

**DE** = drive end **NDE** = non drive end

(F 12)

	<b>DE</b>		<b>NDE</b>	
	<b>M, M_FD, M_FA</b>		<b>M</b>	<b>M_FD, M_FA</b>
<b>M05</b>	6004 2Z C3		6201 2Z C3	6201 2RS C3
<b>M1</b>	6004 2Z C3		6202 2Z C3	6202 2RS C3
<b>M2</b>	6007 2Z C3		6204 2Z C3	6204 2RS C3
<b>M3</b>	6207 2Z C3		6206 2Z C3	6206 2RS C3
<b>M4</b>	6309 2Z C3		6308 2Z C3	6308 2RS C3
<b>M5</b>	6309 2Z C3		6309 2Z C3	6309 2RS C3

(F 13)

	<b>DE</b>		<b>NDE</b>	
	<b>BN, BN_FD, BN_FA</b>		<b>BN</b>	<b>BN_FD, BN_FA</b>
<b>BN 56</b>	6201 2Z C3		6201 2Z C3	—
<b>BN 63</b>	6201 2Z C3		6201 2Z C3	6201 2RS C3
<b>BN 71</b>	6202 2Z C3		6202 2Z C3	6202 2RS C3
<b>BN 80</b>	6204 2Z C3		6204 2Z C3	6204 2RS C3
<b>BN 90</b>	6205 2Z C3		6205 2Z C3	6305 2RS C3
<b>BN 100</b>	6206 2Z C3		6206 2Z C3	6206 2RS C3
<b>BN 112</b>	6306 2Z C3		6306 2Z C3	6306 2RS C3
<b>BN 132</b>	6308 2Z C3		6308 2Z C3	6308 2RS C3
<b>BN 160MR</b>	6309 2Z C3		6308 2Z C3	6308 2RS C3
<b>BN 160M/L</b>	6309 2Z C3		6309 2Z C3	6309 2RS C3
<b>BN 180M</b>	6310 2Z C3		6309 2Z C3	6309 2RS C3
<b>BN 180L</b>	6310 2Z C3		6310 2Z C3	6310 2RS C3
<b>BN 200L</b>	6312 2Z C3		6310 2Z C3	6310 2RS C3



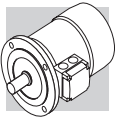

## M4 ELECTRICAL CHARACTERISTICS

### M4.1 Voltage



Single speed motors are provided in standard execution either for nominal voltage 230 / 400 V  $\Delta/Y$ , 50 Hz, or 400 / 690 V  $\Delta/Y$ , 50 Hz, with a voltage tolerance of  $\pm 10\%$ , according to what is specified on the below table.

On all the motors BN and M, for which the voltage / frequency configuration is not included on the below table, the voltage tolerance is reduced down to  $\pm 5\%$ .

For the operation out of the tolerance boundaries, the temperature may exceed by 10 K the limit provided by the adopted insulation class.

The motors are suitable for operation on distribution European grid with voltage complying with the publication IEC 60038.

(F 14)

			$V_{mot}$ $\pm 10\%$ 3 ~	Configuration
IE1	BN 56 ... BN 132	M0 ... M4	230 / 400 V - $\Delta/Y$ - 50 Hz	Standard
			400 / 690 V - $\Delta/Y$ - 50 Hz	On request at no extra charge
			460 V Y - 60 Hz	Standard
	BN 160 ... 200	M5	400 / 690 V - $\Delta/Y$ - 50 Hz	Standard
			460 V $\Delta$ - 60 Hz	Standard

<sup>1</sup> 4 pole motor only

The only rated voltage for motors type 50Hz and all double speed motors is 400V.

Applicable tolerances as per CEI EN 60034-1.

The table below shows the wiring options available.

(F 15)

Pole		Wiring options
2	BN 63 ... BN 200	$\Delta / Y^{(2)}$
4	BN 56 ... BN 200	
6	BN 63 ... BN 200	
8	BN 71 ... BN 132	$\Delta / YY$ (Dahlander)
2/4	BN 63 ... BN 132	
2/6	BN 71 ... BN 132	Y / Y (Two windings)
2/8	BN 71 ... BN 132	
2/12	BN 80 ... BN 132	
4/6	BN 71 ... BN 132	
4/8	BN 80 ... BN 132	$\Delta / YY$ (Dahlander)

<sup>(2)</sup> Motors with voltage in ratio 2 (ex. 230/460 - 60) will be equipped with a 9 pin terminal box with winding connection either  $\Delta\Delta/\Delta$  or  $YY/Y$  (except 6 pole BN 63  $\Delta/Y$ )

## M4.2 Frequency

Rated output power BN / M for 60 Hz operation is shown in the following diagram.

(F 16)

		P <sub>n</sub> [kW]						P <sub>n</sub> [kW]			
		2P	4P	6P	8P (*)			2P	4P	6P	8P (*)
BN 56A	–	–	0.07	–	–	BN 100L	M3LA	3.5	–	–	–
BN 56B	M0B	–	0.1	–	–	BN 100LA		–	2.5	1.8	0.9
BN 63A	M05A	0.21	0.14	0.1	–	BN 100LB	M3LB	4.7	3.5	2.2	1.3
BN 63B	M05B	0.3	0.21	0.14	–	BN 112M		4.7	4.7	2.5	1.8
BN 63C	M05C	0.45	0.3	–	–		M3LC	–	4.7	2.5	–
BN 71A		0.45	0.3	0.21	0.1	BN 132S	M4SA	–	6.5	3.5	2.5
	M1SC	–	–	0.21	–	BN 132SA		6.5	–	–	–
BN 71B	M05SD	0.65	0.45	0.3	0.14	BN 132SB	M4SB	8.7	–	–	–
BN 71C	M1LA	0.9	0.65	0.45	–	BN 132M		11	–	–	3.5
BN 80A	–	0.9	0.65	0.45	0.21	BN 132MA	M4LA	–	8.7	4.6	–
BN 80B	M2SA	1.3	0.9	0.65	0.30	BN 132MB	M4LB	–	11	6.5	–
BN 80C	M2SB	1.8	1.3	0.9	–	BN 160MR	M4LC	12.5	12.5	–	–
BN 90S		–	1.3	0.9	0.45	BN 160M	M5SA	–	–	8.6	–
BN 90SA	–	1.8	–	–	–	BN 160MB		17.5	–	–	–
BN 90SB		2.2	–	–	–		M5SB	17.5	17.5	–	–
BN 90L		2.5	–	1.3	0.65	BN 160L		21.5	17.5	12.6	–
BN 90LA	M3SA	–	1.8	–	–		M5SC	21.5	–	–	–
BN 90LB	–	–	2.2	–	–	BN 180M	M5LA	24.5	21.5	–	–
						BN 180L	–	–	25.3	17.5	–
						BN 200L	–	–	34	–	–
						BN 200LA	–	34	–	22	–

(\*) Excluded M<sub>1</sub> motors

Double speed BN / M motors supplied at 60 Hz will have an increase of nominal power, referred to 50 Hz, equal to 15%.

If a nominal power rating, equal to the normalised nominal power rating at 50 Hz, was requested to be on a nameplate of a motor meant to be voltage supplied at 60 Hz, the PN option shall be specified on the motor designation. Motors normally designed for a 50 Hz frequency may be used on a 60 Hz operating grid, but the related data shall be updated according to the following table.

Motors designated for 50 Hz operation show on the nameplate also the values for 60 Hz operation (excluding motors in CUS execution and brake motors). See the following table.

(F 17)

50 Hz	60 Hz			
V - 50 Hz	V - 60 Hz	P <sub>n</sub> - 60 Hz	M <sub>n</sub> , M <sub>a</sub> /M <sub>n</sub> - 60 Hz	n [min <sup>-1</sup> ] - 60 Hz
230/400 Δ/Y	220 - 240 Δ	1	0.83	1.2
	380 - 415 Y			
400/690 Δ/Y	380 - 415 Δ	1.15	1	1.2
230/400 Δ/Y	265 - 280 Δ			
	440 - 480 Y			
400/690 Δ/Y	440 - 480 Δ			

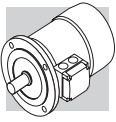

### M4.3 Ambient temperature

Catalogue rating values are calculated for 50 Hz operation and for standard ambient conditions (temperature 40 °C; elevation <1000 m a.s.l.) as per the CEI EN 60034-1 Standards.

The motors can be used within the 40 - 60 °C temperature range with rated power output adjusted by factors given in the following charts.

(F 18)

Ambient temperature (°C)	40°	45°	50°	55°	60°
Permitted power as a % of rated power	100%	95%	90%	85%	80%

Should a derating factor higher than 15% apply please consult factory.

### M4.4 Insulation class

#### CL F

Bonfiglioli motors use class **F** insulating materials (enamelled wire, insulators, impregnation resins) as compare to the standard motor.

#### CL H

Motors manufactured in insulation class **H** are available at request.

In standard motors, stator windings over temperature normally stays below the 80 K limit corresponding to class B over temperature. A careful selection of insulating components makes the motors compatible with tropical climates and normal vibration. For applications involving the presence of aggressive chemicals or high humidity, contact Bonfiglioli Engineering for assistance with product selection. Not available for motors in compliance with CSA e UL standards (CUS option).

(F 19)

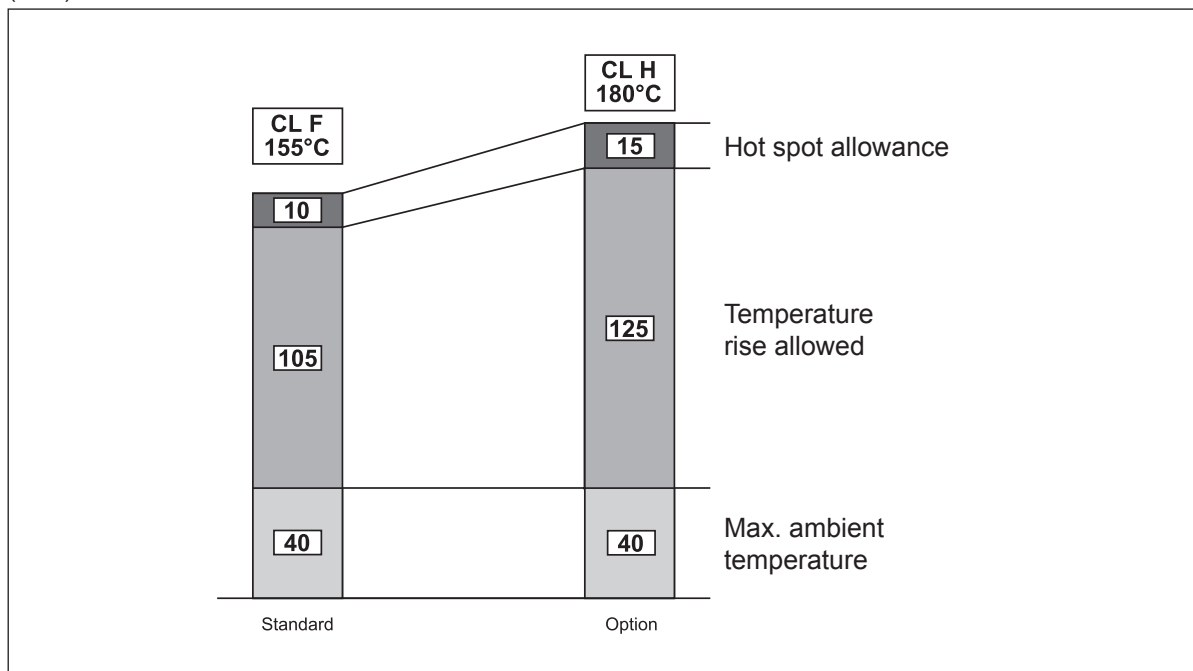

## M4.5 Type of duty

Unless otherwise specified, catalogue motor power refers to continuous duty S1.

Any operating conditions other than S1 duty must be identified in accordance with duty cycle definitions laid down in standards CEI EN 60034-1. For duty cycles S2 and S3, the power increase coefficient reported in the following table may be used. Please note that the table provided below applies to single-speed motors. As an alternative to S1 continuous duty, one of the following values can be specified at the product configuration stage: S2, S3 or S9. The motor nameplate will be marked with an increased power rating to suit the type of duty, and with specific electrical data and a duty type of S2-30 min, S3-70% or S9 respectively.

For further details, contact Bonfiglioli's Technical Service.

Please contact Bonfiglioli Engineering for the power increase coefficients applicable to switch-pole motors.

(F 20)

	Duty						Consult factory
	S2			S3 *			
	Cycle duration (min)			Cyclic duration factor ( I )			
	10	30 (*)	60	25%	40%	70% (*)	
$f_m$	1.35	1.15	1.05	1.25	1.15	1.1	

\* Cycle duration must, in any event, be equal to or less than 10 minutes; if this time is exceeded, please contact our Technical Service.

(\*) Default values from options.

### M4.5.1 Cyclic duration factor:

$$I = \frac{t_f}{t_f + t_r} \cdot 100 \quad (23)$$

$t_f$  = work time under constant load

$t_r$  = rest time

### M4.5.2 Limited duration duty S2

This type of duty is characterized by operation at constant load for a limited time, which is shorter than the time required to reach thermal equilibrium, followed by a rest period of sufficient duration to restore ambient temperature in the motor.

### M4.5.3 Periodical intermittent duty S3:

This type of duty is characterized by a sequence of identical operation cycles, each including a constant load operation period and a rest period.

For this type of duty, the starting current does not significantly influence overtemperature.

#### M4.6 Inverter-controlled motors

The electric motors of series BN and M may be used in combination with PWM inverters with rated voltage at transformer input up to 500 V. Standard motors use a phase insulating system with separators, class 2 enamelled wire and class H impregnation resins (1600V peak-to-peak voltage pulse capacity and rise edge  $t_s > 0.1 \mu s$  at motor terminals). The following table shows the typical torque/speed curves referred to S1 duty for motors with base frequency  $f_b = 50$  Hz.

Because ventilation is somewhat impaired in operation at lower frequencies (about 30 Hz), standard motors with incorporated fan (IC411) require adequate torque derating or - alternately - the addition of a separate supply fan cooling.

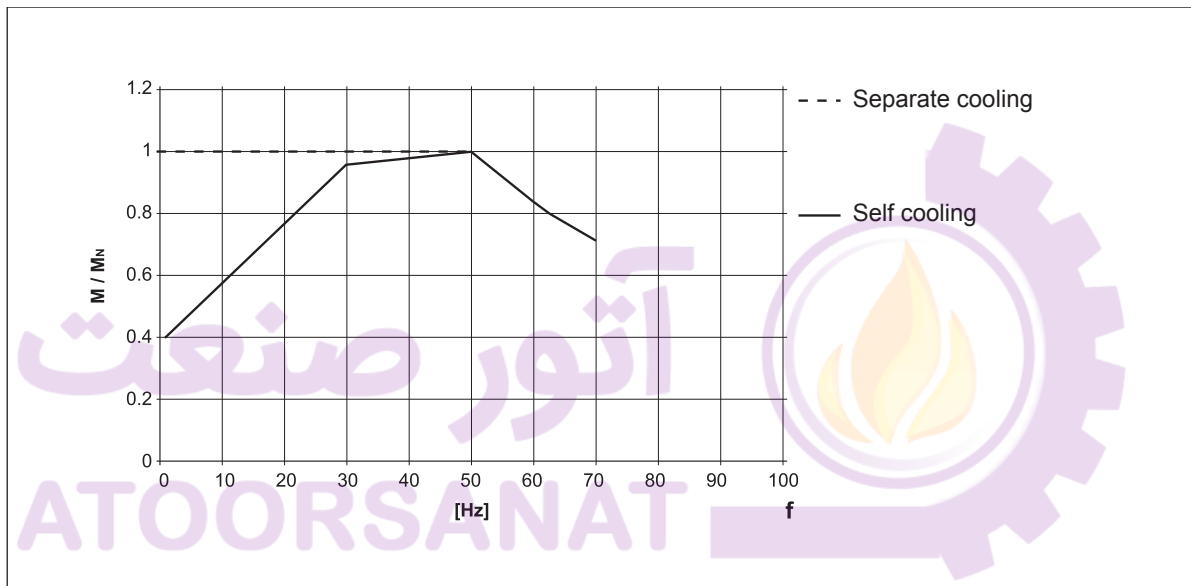

Above base frequency, upon reaching the maximum output voltage of the inverter, the motor enters a steady-power field of operation, and shaft torque drops with ratio  $(f/f_b)$ . As motor maximum torque decreases with  $(f/f_b)^2$ , the allowed overloading must be reduced progressively.

(F 21)



The following table reports the mechanical limit speed for motor operation above rated frequency:

(F 22)

		n [min <sup>-1</sup> ]		
		2p	4p	6p
				
≤ BN 112	M05...M3	5200	4000	3000
≥ BN 132	M4, M5	4500	4000	3000

Above rated speed, motors generate increased mechanical vibration and fan noise. Class B rotor balancing is highly recommended in these applications. Installing a separate supply fan cooling may also be advisable.

Remote-controlled fan and brake (if fitted) must always be connected direct to mains power supply.

#### M4.7 Permissible starts per hour, Z

The rating charts of brakemotors lend the permitted number of starts  $Z_0$ , based on 50% intermittence and for unloaded operation.

The catalogue value represents the maximum number of starts per hour for the motor without exceeding the rated temperature for the insulation class F.

To give a practical example for an application characterized by inertia  $J_c$ , drawing power  $P_r$  and requiring mean torque at start-up  $M_L$  the actual number of starts per hour for the motor can be calculated approximately through the following equation:

$$Z = \frac{Z_0 \cdot K_c \cdot K_d}{K_J} \quad (24)$$

where:

$$K_J = \frac{J_m + J_c}{J_m} \quad \text{inertia factor}$$

$$K_c = \frac{M_a - M_L}{M_a} \quad \text{torque factor}$$

$$K_d = \quad \text{load factor see table (F23)}$$

(F 23)

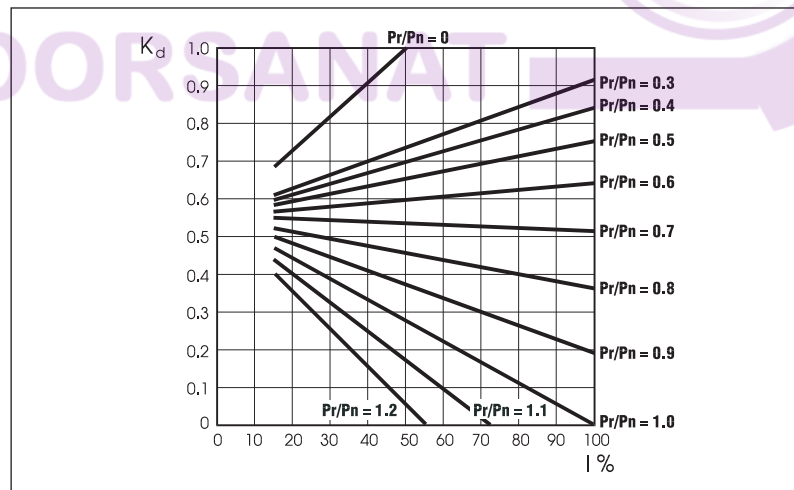

If actual starts per hour is within permitted value ( $Z$ ) it may be worth checking that braking work is compatible with brake (thermal) capacity  $W_{max}$  also given in tables (F30), (F38) and dependent on the number of switches (c/h).

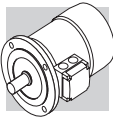

## M5 ASYNCHRONOUS BRAKE MOTORS

### M5.1 Operation

Versions with incorporated brake use spring-applied DC (FD option) or AC (FA options) brakes. All brakes are designed to provide fail-safe operation, meaning that they are applied by spring-action in the event of power failure.

(F 24)

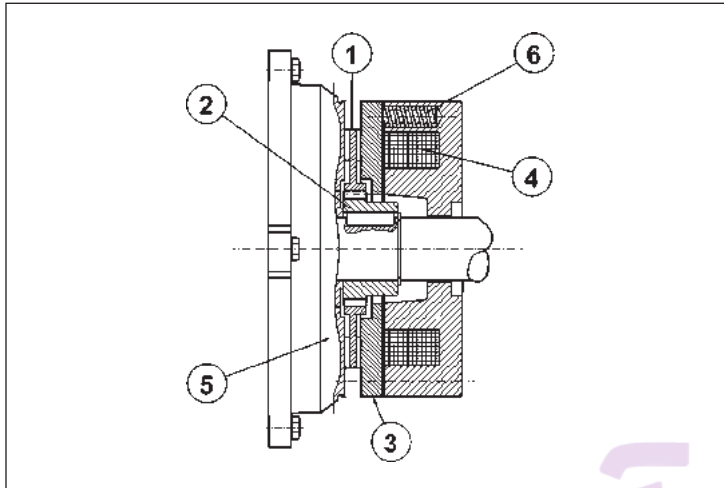

Key:

- ① brake disc
- ② disc carrier
- ③ pressure plate
- ④ brake coil
- ⑤ motor rear shield
- ⑥ brake springs

When voltage is interrupted, pressure springs push the armature plate against the brake disc. The disc becomes trapped between the armature plate and motor shield and stops the shaft from rotation. When the coil is energized, a magnetic field strong enough to overcome spring action attracts the armature plate, so that the brake disc – which is integral with the motor shaft – is released.

### M5.2 Most significant features

- High braking torques (normally  $M_b \approx 2 M_n$ ), braking torque adjustment.
- Steel brake disc with double friction lining (low-wear, asbestos-free lining).
- Hexagonal seat on motor shaft fan end (N.D.E.) for manual rotation (not compatible with options PS, RC, TC, U1, U2, EN1, EN2, EN3, EN4, EN5, EN6).
- Manual release lever (options **R** and **RM** for BN/M\_FD; option **R** for BN/M\_FA).
- Corrosion-proof treatment on all brake surfaces.
- Insulation class F.

## M6 DC BRAKE MOTORS TYPE BN\_FD and M\_FD

Frame sizes: BN 63 ... BN 200L / M05 ... M5

(F 25)

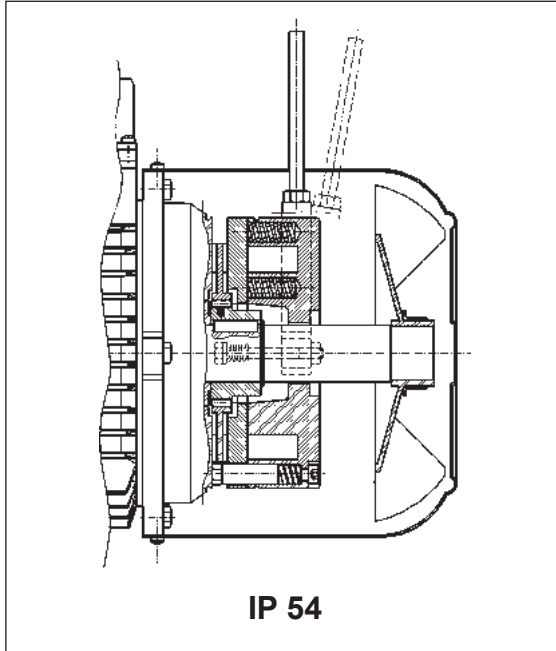

(F 26)

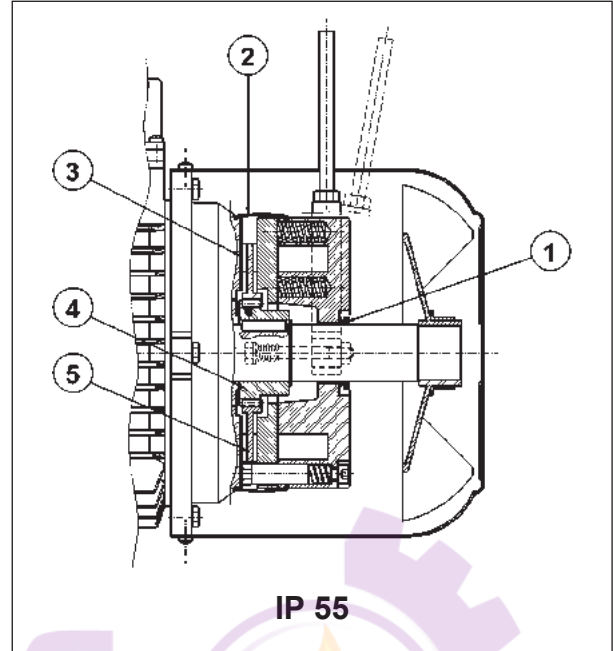

**Direct current** toroidal-coil electromagnetic brake bolted onto motor shield. Preloading springs provide axial positioning of magnet body.

Brake disc slides axially on steel hub shrunk onto motor shaft with anti-vibration device.

Brake torque factory setting is indicated in the corresponding motor rating charts. Braking torque may be modified by changing the type and/or number of springs.

At request, motors may be equipped with manual release lever with automatic return (**R**) or system for holding brake in the released position (**RM**).

See variant at paragraph "BRAKE RELEASE SYSTEMS" for available release lever locations.

FD brakes ensure excellent dynamic performance with low noise. DC brake operating characteristics may be optimized to meet application requirements by choosing from the various rectifier/power supply and wiring connection options available.

**For applications involving lifting and/or high hourly energy dissipation, contact Bonfiglioli's Technical Service.**

### M6.1 Degree of protection

Standard protection class is IP54.

Brake motor FD is also available in protection class **IP55**, which mandates the following variants:

- ① V-ring at N.D.E. of motor shaft
- ② dust and water-proof rubber boot
- ③ stainless steel ring placed between motor shield and brake disc
- ④ stainless steel hub
- ⑤ stainless steel brake disc



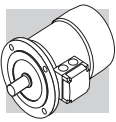



## M6.2 FD brake power supply

A rectifier accommodated inside the terminal box feeds the DC brake coil. Wiring connection across rectifier and brake coil is performed at the factory.

On all single-pole motors, rectifier is connected to the motor terminal board.

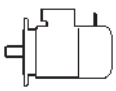

Rectifier standard power supply voltage  $V_B$  is as indicated in the following table, regardless of mains frequency:

(F 27)

2, 4, 6 P				1 speed		
		<b>BN_FD / M_FD</b> $V_{mot} \pm 10\%$ 3 ~		$V_B \pm 10\%$ 1 ~	brake connected to terminal board power supply	separate power supply
<b>BN 63...BN 132</b>	<b>M05...M4LB</b>	230/400 V – 50 Hz	230 V	standard	standard	specify $V_B$ SA o $V_B$ SD
<b>BN 160...BN 200</b>	<b>M4LC...M5</b>	400/690 V – 50 Hz	400 V	standard	standard	specify $V_B$ SA o $V_B$ SD

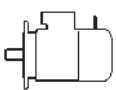

Switch-pole motors feature a separate power supply line for the brake with rectifier input voltage  $V_B$  as indicated in the table below:

(F 28)

2/4, 2/6, 2/8, 2/12, 4/6, 4/8 P				2 speed		
		<b>BN_FD / M_FD</b> $V_{mot} \pm 10\%$ 3 ~		$V_B \pm 10\%$ 1 ~	brake connected to terminal board power supply	separate power supply
<b>BN 63...BN 132</b>	<b>M05...M4LB</b>	400 V – 50 Hz	230 V		standard	specify $V_B$ SA o $V_B$ SD

The diode half-wave rectifier ( $V_{DC} \approx 0,45 \times V_{AC}$ ) is available in versions **NB**, **SB**, **NBR** e **SBR**, as detailed in the table below:

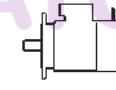
(F 29)

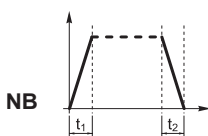
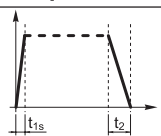
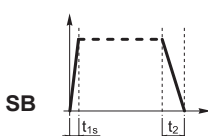
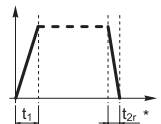
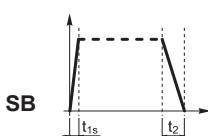
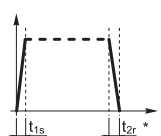
		brake	standard	at request
<b>BN 63</b>	<b>M05</b>	<b>FD 02</b>		
<b>BN 71</b>	<b>M1</b>	<b>FD 03</b> <b>FD 53</b>		
<b>BN 80</b>	<b>M2</b>	<b>FD 04</b>		
<b>BN 90S</b>	—	<b>FD 14</b>		
<b>BN 90L</b>	—	<b>FD 05</b>		
<b>BN 100</b>	<b>M3</b>	<b>FD 15</b>		
—	—	<b>FD 55</b>		
<b>BN 112</b>	—	<b>FD 06S</b>		
<b>BN 132 - BN 160MR</b>	<b>M4</b>	<b>FD 56</b> <b>FD 06</b> <b>FD 07</b>		
<b>BN 160L - BN 180M</b>	<b>M5</b>	<b>FD 08</b>		
<b>BN 180L - BN 200M</b>	—	<b>FD 09</b>		

(\*)  $t_{2c} < t_{2r} < t_2$

Rectifier **SB** with electronic energizing control over-energizes the electromagnet upon power-up to cut brake release response time and then switches to normal half-wave operation once the brake has been released.

Use of the **SB** rectifier is mandatory in the event of:

- high number of operations per hour
- reduced brake release response time
- brake is exposed to extreme thermal stress

Rectifiers **NBR** or **SBR** are available for applications requiring quick brake intervention (braking condition reinstatement) response.

These rectifiers complement the **NB** and **SB** types as their electronic circuit incorporates a static switch that de-energizes the brake quickly in the event voltage is missing.

This arrangement ensures short brake release response time with no need for additional external wiring and contacts.

Optimum performance of rectifiers **NBR** and **SBR** is achieved with separate brake power supply.

**Versions available: 230Vac ±10%, 400Vac ± 10%, 50/60 Hz (with power supply); 100Vdc ±10%, 180Vdc ± 10% (with SD option).**

### M6.3 FD brake technical specifications

The table below reports the technical specifications of DC brakes FD.

(F 30)

Brake	Brake torque $M_b$ [Nm]			Release		Braking		$W_{max}$ per brake operation			W	P
	springs			$t_1$	$t_{1s}$	$t_2$	$t_{2c}$	[ J ]				
	6	4	2	[ms]	[ms]	[ms]	[ms]	10 s/h	100 s/h	1000 s/h		
FD02	–	3.5	1.75	30	15	80	9	4500	1400	180	15	17
FD03	5	3.5	1.75	50	20	100	12					
FD53	7.5	5	2.5	60	30	100	12	7000	1900	230	25	24
FD04	15	10	5	80	35	140	15	10000	3100	350	30	33
FD14												
FD05	40	26	13	130	65	170	20	18000	4500	500	50	45
FD15	40	26	13	130	65	170	20					
FD55	55	37	18	–	65	170	20					
FD06S	60	40	20	–	80	220	25	20000	4800	550	70	55
FD56	–	75	37	–	90	250	20	29000	7400	800	80	65
FD06		100	50		100	250	20					
FD07	150	100	50	–	120	200	25	40000	9300	1000	130	65
FD08*	250	200	170	–	140	350	30	60000	14000	1500	230	100
FD09**	400	300	200	–	200	450	40	70000	15000	1700	230	120

\* brake torque values obtained with 9, 7 and 6 springs, respectively

\*\* brake torque values obtained with 12, 9 and 6 springs, respectively

$t_1$  = brake release time with half-wave rectifier  
 $t_{1s}$  = brake release time with over-energizing rectifier  
 $t_2$  = brake engagement time with AC line interruption and separate power supply

$t_{2c}$  = brake engagement time with AC and DC line interruption – Values for  $t_1$ ,  $t_{1s}$ ,  $t_2$ ,  $t_{2c}$  indicated in the tab. (F30) are referred to brake set at maximum torque, medium air gap and rated voltage

$W_{max}$  = max energy per brake operation

W = braking energy between two successive air gap adjustments

$P_b$  = brake power absorption at 20 °C

$M_b$  = static braking torque (±15%)

s/h = starts per hour

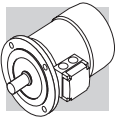

The brake pad wear depends on the operating/ambient conditions (temperature, humidity, angular speed, specific pressure); Therefore the declared wear rate must be considered as indicative.

#### M6.4 FD brake connections

On standard single-pole motors, the rectifier is connected to the motor terminal board at the factory. For switch-pole motors and where a separate brake power supply is required, connection to rectifier must comply with brake voltage VB stated in motor name plate.

**Because the load is of the inductive type, brake control and DC line interruption must use contacts from the usage class AC-3 to IEC 60947-4-1.**

Table (F31) – Brake power supply from motor terminals and AC line interruption  
Delayed stop time  $t_2$  and function of motor time constants.

Mandatory when soft-start/stops are required.

Table (F32) – Brake coil with separate power supply and AC line interruption  
Normal stop time independent of motor.

Achieved stop times  $t_2$  are indicated in the table (F30).

Table (F33) – Brake coil power supply from motor terminals and AC/DC line interruption.

Quick stop with operation times  $t_{2c}$  as per table (F30).

Table (F34) – Brake coil with separate power supply and AC/DC line interruption.

Stop time decreases by values  $t_{2c}$  indicated in the table (F30).

The brake may be voltage supplied directly from the motor terminal box (from tab. F31 to tab. F34) only if the nominal voltage of the brake is the same as the smaller voltage of the motor.

(F 31)

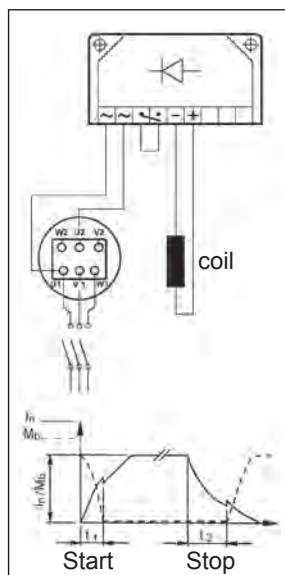

(F 32)

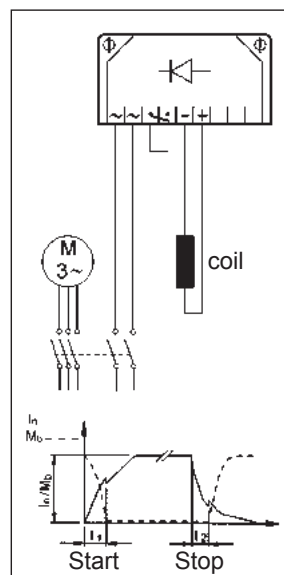

(F 33)

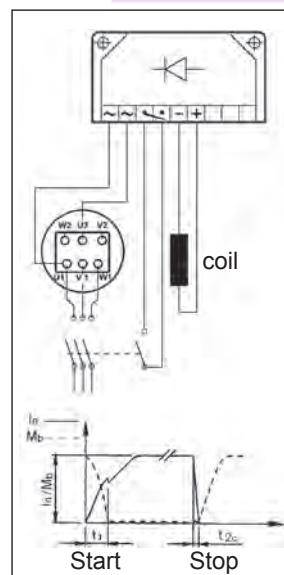

(F 34)

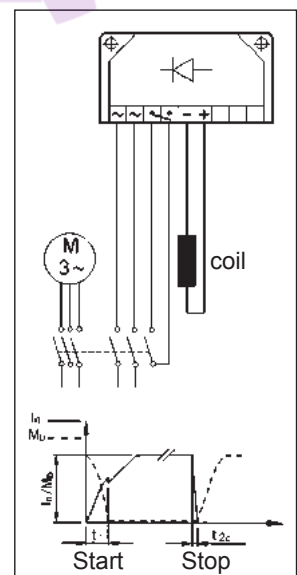

## M7 AC BRAKE MOTORS TYPE BN\_FA and M\_FA

Frame sizes: BN 63 ... BN 180M / M05 ... M5

(F 35)

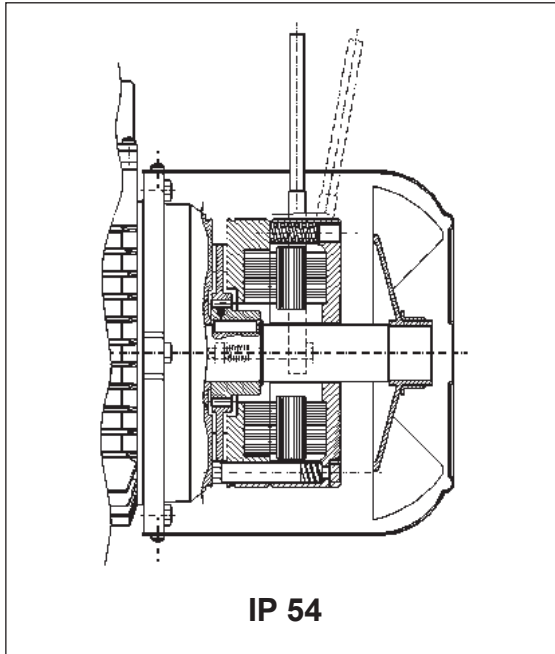

(F 36)

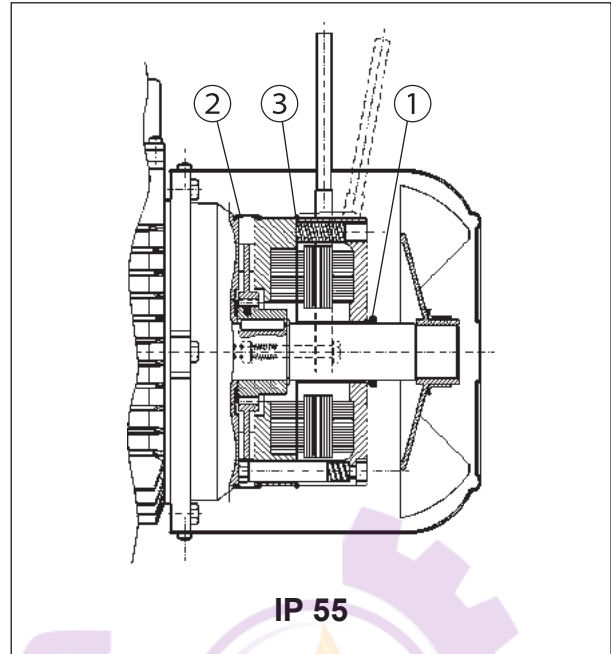

Electromagnetic brake operates from three-phase **alternated current** power supply and is bolted onto conveyor shield. Preloading springs provide axial positioning of magnet body. Steel brake disc slides axially on steel hub shrunk onto motor shaft with anti-vibration device. Brake torque factory setting is indicated in the corresponding motor rating charts. Spring preloading screws provide stepless braking torque adjustment. Torque adjustment range is  $30\% M_{bMAX} < M_b < M_{bMAX}$  (where  $M_{bMAX}$  is maximum braking torque as shown in tab. (F38).

Thanks to their high dynamic characteristics, FA brakes are ideal for heavy-duty applications as well as applications requiring frequent stop/starts and very fast response time.

Motors may be equipped with manual release lever with automatic return (**R**) at request. See variant at paragraph "BRAKE RELEASE SYSTEMS" for available release lever locations.

**For applications involving lifting and/or high hourly energy dissipation, contact Bonfiglioli's Technical Service.**

### M7.1 Degree of protection

Standard protection class is IP54.

Brake motor FA is also available in protection class **IP55**, which mandates the following variants:

- ① V-ring at N.D.E. of motor shaft
- ② dust and water-proof rubber boot
- ③ O-ring

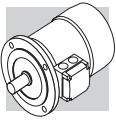

## M7.2 FA brake power supply

In single speed motors, power supply is brought to the brake coil direct from the motor terminal box. As a result, brake voltage and motor voltage are the same. In this case, brake voltage indication may be omitted in the designation.

Switch-pole motors and motors with separate brake power supply feature an auxiliary terminal board with 6 terminals for connection to brake line. In both cases, brake voltage indication in the designation is mandatory. The following table reports standard AC brake power supply ratings for single- and switch-pole motors:

(F 37)

single-pole motor	BN 63...BN 132	BN 160...BN 180
	M05...M4LB	M4LC...M5
	230Δ / 400Y V ±10% – 50 Hz	400Δ/ 690Y V ±10% – 50 Hz
	265Δ / 460Y ±10% - 60 Hz	460Y – 60 Hz

switch-pole motors (separate power supply line)	BN 63...BN 132
	M05...M4
	230Δ / 400Y V ±10% – 50 Hz
	460Y - 60 Hz

Unless otherwise specified, standard brake power supply is 230Δ /400Y V - 50 Hz.

Special voltages in the 24...690 V, 50-60 Hz range are available at request.

## M7.3 Technical specifications of FA brakes

(F 38)

Brake	Brake torque $M_b$ [Nm]	Release $t_1$ [ms]	Braking $t_2$ [ms]	$W_{max}$ [ J ]			W [MJ]	P [VA]
				10 s/h	100 s/h	1000 s/h		
FA 02	3.5	4	20	4500	1400	180	15	60
FA 03	7.5	4	40	7000	1900	230	25	80
FA 04	15	6	60	10000	3100	350	30	110
FA 14								
FA 05	40	8	90	18000	4500	500	50	250
FA 15								
FA 06S	60	16	120	20000	4800	550	70	470
FA 06	75	16	140	29000	7400	800	80	550
FA 07	150	16	180	40000	9300	1000	130	600
FA 08	250	20	200	60000	14000	1500	230	1200

$M_b$  = max static braking torque (±15%)

$t_1$  = brake release time

$t_2$  = brake engagement time

$W_{max}$  = max energy per brake operation (brake thermal capacity)

W = braking energy between two successive air gap adjustments

$P_b$  = power drawn by brake at 20° (50 Hz)

s/h = starts per hour

NOTE

Values  $t_1$  and  $t_2$  in the table refer to a brake set at rated torque, medium air gap and rated voltage.

The brake pad wear depends on the operating/ambient conditions (temperature, humidity, angular speed, specific pressure); Therefore the declared wear rate must be considered as indicative.

#### M7.4 FA brake connections

The diagram below shows the wiring when brake is connected directly to same power supply of the motor:

(F 39)

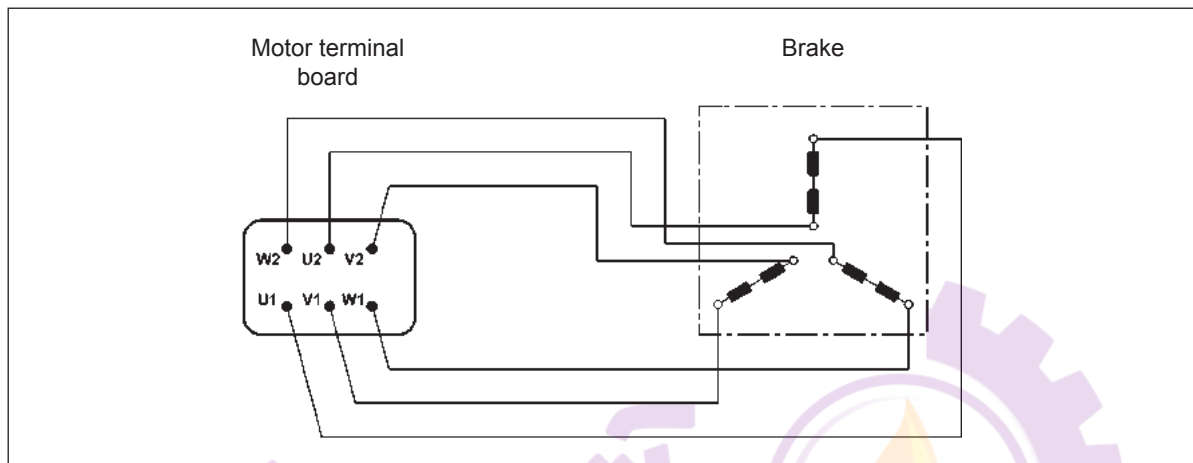

Switch-pole motors and, at request, single-pole motors with separate power supply are equipped with an auxiliary terminal board with 6 terminals for brake connection.

In this version, motors feature a larger terminal box. See diagram below:

(F 40)

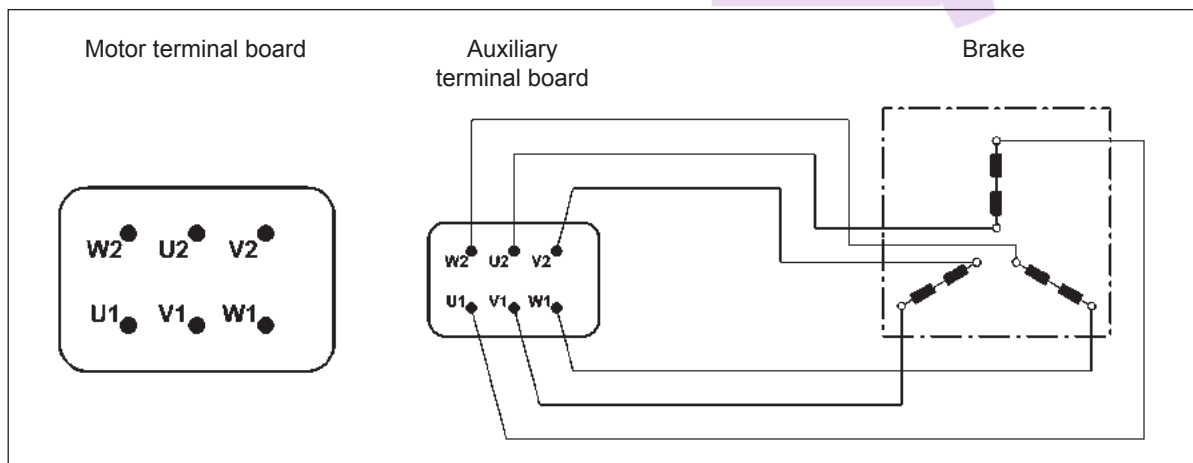

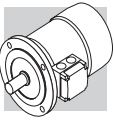

## M8 BRAKE RELEASE SYSTEMS

Spring-applied brakes type FD and FA may be equipped with optional manual release devices. These are typically used for manually releasing the brake before servicing any machine or plant parts operated by the motor.

R

(F 41)

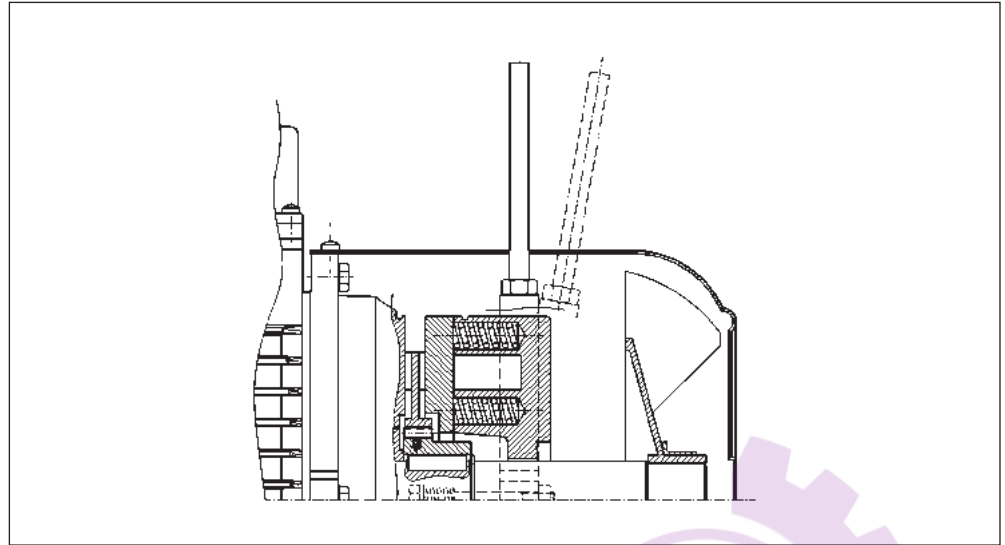

A return spring brings the release lever back in the original position.

RM

(F 42)

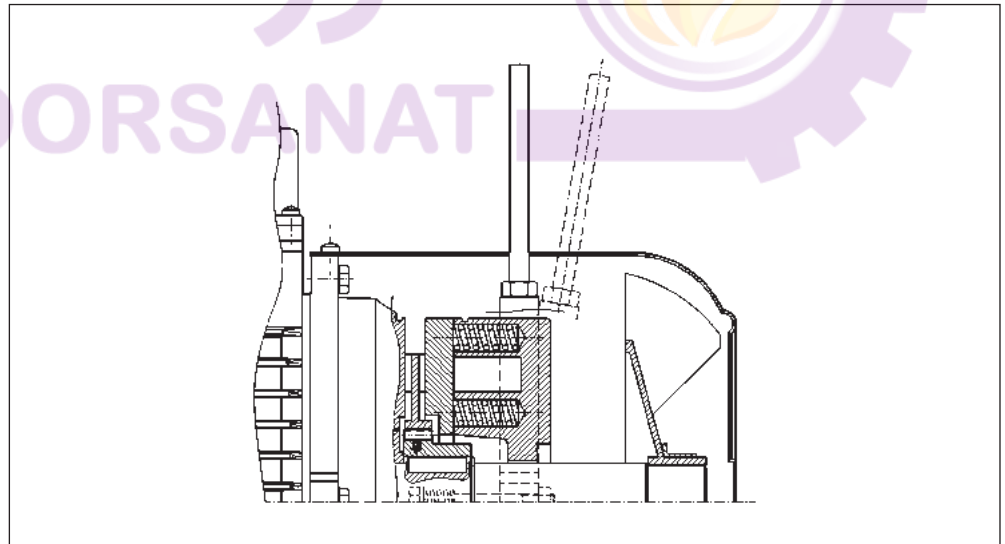

On motors type BN\_FD, if the option RM is specified, the release device may be locked in the "release" position by tightening the lever until its end becomes engaged with a brake housing projection. The availability for the various disengagement devices is charted here below:

(F 43)

	R	RM
BN_FD	BN 63...BN 200	2p 63A2 ≤ H ≤ 132M2 4p 63A4 ≤ H ≤ 132MA4 6p 63A6 ≤ H ≤ 132MA6
M_FD	M 05...M 5	M 05...M 4LA
BN_FA	BN 63...BN 180M	●
M_FA	M 05...M 5	

### M8.1 Release lever orientation

Unless otherwise specified, the release lever is located 90° away from the terminal box – identified by letters [AB] in the diagram below – in a clockwise direction on both options R and RM. Alternative lever positions [AA], [AC] and [AD] are also possible when the corresponding option is specified:

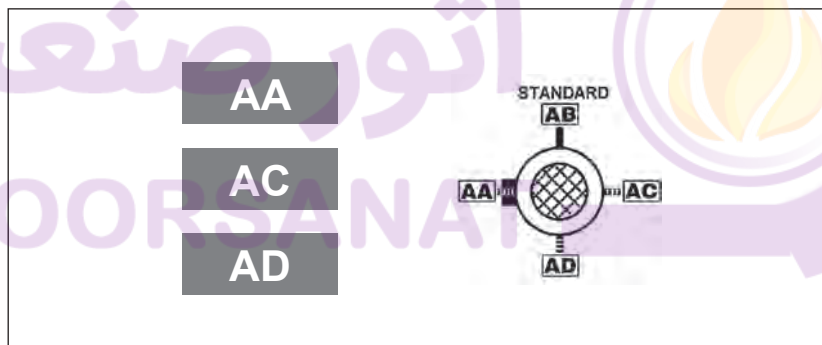

(F 44)



### M8.2 Fly-wheel data (F1)

The table below shows values of weight and inertia of flywheel (option F1). Overall dimensions of motors remain unchanged.

(F 45)

Main data for flywheel of motore type: BN_FD, M_FD			
		Fly-wheel weight [Kg]	Fly-wheel inertia [Kgm <sup>2</sup> ]
BN 63	M05	0.69	0.00063
BN 71	M1	1.13	0.00135
BN 80	M2	1.67	0.00270
BN 90 S - BN 90 L	–	2.51	0.00530
BN 100	M3	3.48	0.00840
BN 112	–	4.82	0.01483
BN 132 S - BN 132 M	M4	6.19	0.02580



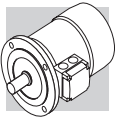

## M9 OPTIONS

### M9.1 Thermal protective devices

In addition to the standard protection provided by the magneto-thermal device, motors can be supplied with built-in thermal probes to protect the winding against overheating caused, by insufficient ventilation or by an intermittent duty.

This additional protection should always be specified for servoventilated motors (IC416).

### M9.2 Capacitive filter

CF

An optional capacitive filter is available for DC brake motors type BN\_FD only. When the suitable capacitive filter is installed upstream of the rectifier (option CF), motors comply with the emission limits required by standard EN61000-6-3:2007“ Electromagnetic Compatibility – Generic Emission Standard – Part 6-3: Residential, commercial and light industrial environment”.

### M9.3 Thermistors

E3

These are semi-conductors having rapid resistance variation when they are close to the rated switch off temperature (150 °C).

Variations of the  $R = f(T)$  characteristic are specified under DIN 44081, IEC 34-11 Standards.

Positive temperature coefficient thermistors are normally used (also known as PTC “cold conductor resistors”).

Thermistors cannot control relays directly and must be connected to a suitable disconnect device.

Thus protected, three PTCs connected in series are installed in the winding, the terminals of which are located on the auxiliary terminal-board.

K1

The design characteristics of this sub-group of PTC thermistors allow them to be used as positive temperature coefficient sensors with variable resistance.

Functioning temperature range: 0°C ... +260°C.

Thermistors cannot control relays directly and must be connected to a suitable disconnect device.

Terminals (polarised) for 1 x KTY 84-130 are provided on an auxiliary terminal strip.

### M9.4 Bimetallic thermostates

D3

These types of protective devices house a bimetal disk. When the rated switch off temperature (150 °C) is reached, the disk switches the contacts from their initial rest position.

As temperature falls, the disk and the contacts automatically return to rest position.

Three bimetallic thermostates connected in series are usually employed, with normally closed contacts. The terminals are located on an auxiliary terminal-board.

## M9.5 Plug connector

### CON

Three types of connectors (CON 1, CON 2, CON 3) are provided; they can be mounted in two different positions: right side of terminal box cover (C1D, C2D, C3D); left side of terminal box cover (C1S, C2S, C3S).

The option CON is applicable to single speed BN and M motors (2, 4, 6, 8 poles), and it is not applicable to switch-pole motors. More details about the motor sizes are available in the next table.

The connectors CON 1 / CON 2 are available for BN and M motors without brake and for BN and M brakemotors equipped with DC brake type FD, for the motor sizes listed below.

**The male connector (with pins) is mounted on the motor, the female connector is not provided. With CON option, the winding connection is always Y.**

With option U1 “forced ventilation”, the fan unit supply is available inside the separate terminal box fixed to fan cover.

With options EN1...EN6, the encoder connection is made by a cable not connected to the motor plug connector.

The CON option is not applicable to brakemotors equipped with AC brake type FA. The CON option is not available when at least one of the next options are selected: the U2, CUS, IC.



### Specifications

(F 46)

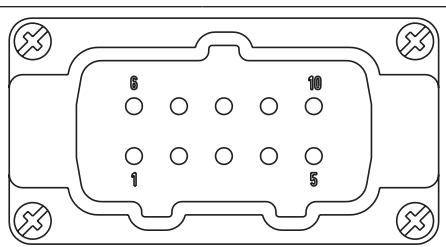
Option	CON 1
Motor size	BN63...BN112 / M05...M3
Connector view	
Type of connector	Harting Han 10ES
Housing	Han EMC 10B with 2 levers
Numbers of pins - nominal current	10 x 16A
Voltage	500 Vac
Contact connection	Screw terminals

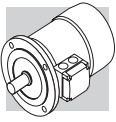

(F 47)

Option	CON 2
Motor size	BN63...BN132M / M05...M4L
Connector view	
Type of connector	Harting Han Modular
Housing	Han EMC 10B with 2 levers
Module type	Module C + Empty module + Module E
Numbers of pins - nominal current	3 x 36A / 6 x 16A
Voltage	500 Vac
Contact connection	Crimping contacts



(F 48)

Option	CON 3
Motor size	BN63...BN132M / M05...M4L
Connector view	
Type of connector	Harting Han Modular
Housing	Han EMC 10B with 2 levers
Module type	Module C + Module E + Module E
Numbers of pins - nominal current	3 x 36A / 6 + 6 x 16A
Voltage	500 Vac
Contact connection	Crimping contacts

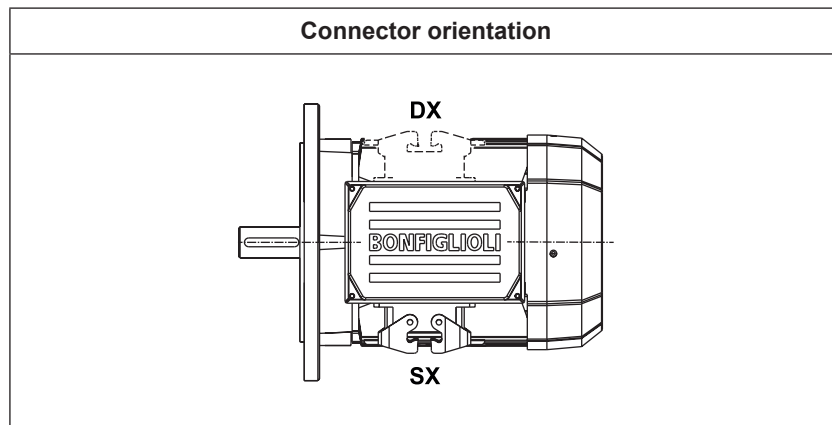
(F 49)



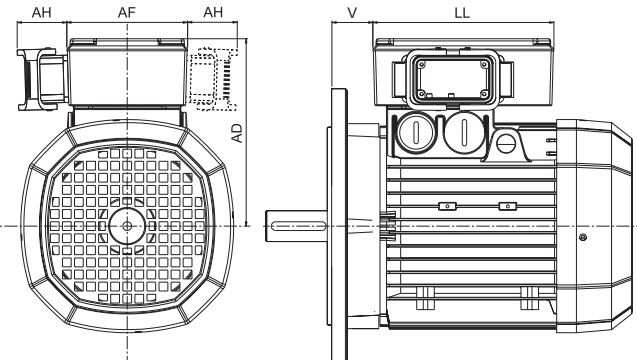

(F 50)

Motors without brake dimensions						
						
		AD (mm)	AF (mm)	AH (mm)	LL (mm)	V <sup>(*)</sup> (mm)
<b>BN63</b>	<b>M05</b>	136	110	45	165	4.5
<b>BN71</b>	<b>M1</b>	149	110	45	165	15.5
<b>BN80</b>	<b>M2</b>	160	110	45	165	16.5
<b>BN90</b>	—	162	110	45	165	31.5
<b>BN100</b>	<b>M3</b>	171	110	45	165	37.5
<b>BN112</b>	—	186	110	45	165	39
<b>BN132</b>	<b>M4</b>	210	140	45	188	45.5
<b>BN160MR</b>	—	210	140	45	188	161

(\*) Dimension valid only for motors BN.

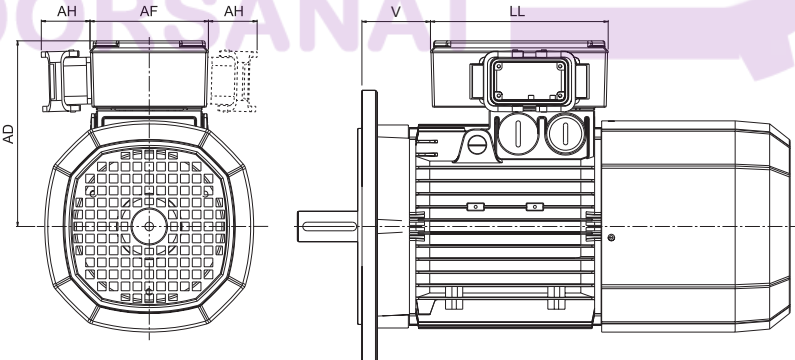
(F 51)

Motors with FD brake dimensions						
						
		AD (mm)	AF (mm)	AH (mm)	LL (mm)	V <sup>(*)</sup> (mm)
<b>BN63</b>	<b>M05</b>	136	110	45	165	4.5
<b>BN71</b>	<b>M1</b>	149	110	45	165	1.5
<b>BN80</b>	<b>M2</b>	160	110	45	165	18.5
<b>BN90</b>	—	162	110	45	165	39.5
<b>BN100</b>	<b>M3</b>	171	110	45	165	63.5
<b>BN112</b>	—	186	110	45	165	75
<b>BN132</b>	<b>M4</b>	210	140	45	188	122
<b>BN160MR</b>	—	210	140	45	188	161

(\*) Dimension valid only for motors BN.

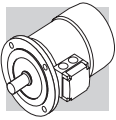

## M9.6 Control of brake operation

### MSW

The microswitch can be set in order to obtain from it a signal related to the attraction/release of an anchor plate, or it can be set in order to give feedback when the air gap reaches the maximum value.

**MSW option is available for brakes FD03...FD09.**

The microswitch is provided with three lead wires (NC, NO, COM). The next figure shown the main components of the brake equipped with microswitch.

(F 52)

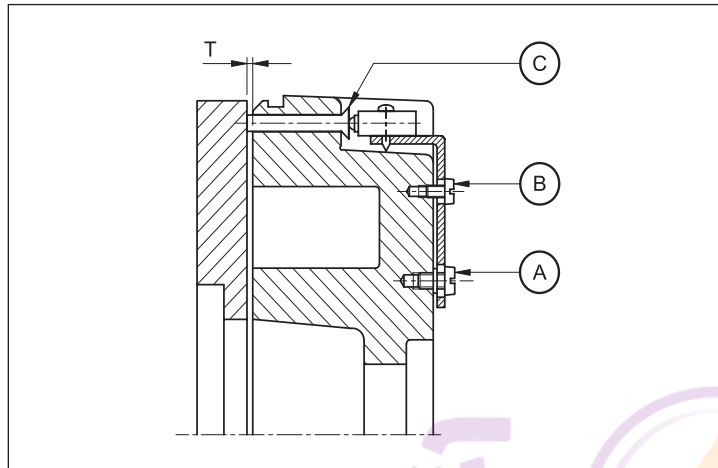

- A: Plate fixing screws
- B: Setting screws
- C: Actuator control pin

## M9.7 Additional cable entry for brakemotors

### IC

The terminal box cover of brakemotors BN63...BN160MR / M05...M4 is provided with two additional cable entry M16 x 1.5 (one cable entry per side).

The terminal box cover of brakemotors BN160...BN200 / M5 is provided with an additional cable entry M16 x 1.5 next to the cable entry used for the brake.

## M9.8 Anti-condensation heaters

### H1

### NH1

Where an application involves high humidity or extreme temperature fluctuation, motors may be equipped with an anti-condensate heater.

A single-phase power supply is available in the auxiliary terminal board inside the main terminal box. Values for the absorbed power are listed here below:

(F 53)

		H1	NH1
		1~ 230V ± 10% P [W]	1~ 115V ± 10% P [W]
BN 56...BN 80	M0...M2	10	10
BN 90...BN 160MR	M3 - M4	25	25
BN 160M...BN 180M	M5	50	50
BN 180L...BN 200L	—		

### Warning!

Always remove power supply to the anti-condensante heater before operating the motor.

## M9.9 Tropicalization

**TP**

When option **TP** is specified, motor windings receive additional protection for operation in high humidity and temperature conditions.

## M9.10 Second shaft extension

**PS**

This option is not compatible with variants RC, TC, U1, U2, EN1, EN2, EN3, EN4, EN5, EN6. For shaft dimensions please see motor dimensions tables.

(F 54)

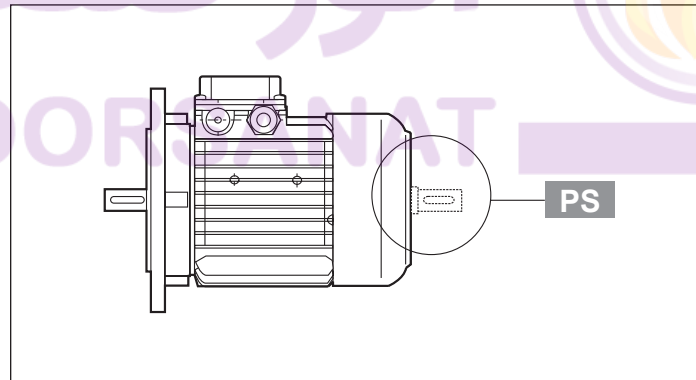

## M9.11 Backstop device

**AL**

**AR**

For applications where backdriving must be avoided, motors equipped with an anti run-back device can be used (available for the M series only). While allowing rotation in the direction required, this device operates instantaneously in case of a power failure, preventing the shaft from running back. The anti run-back device is life lubricated with special grease for this specific application. When ordering, customers should indicate the required rotation direction, AL or AR.

Never use the anti run-back device to prevent reverse rotation caused by faulty electrical connection. Table (F55) shows rated and maximum locking torques for the anti run-back devices. A diagram of the device can be seen in Table (F56). Overall dimensions are same as the corresponding brake motor. The direction of free rotation is described in the "MOTOR OPTIONS" section of specifically dedicated sections to gear units.

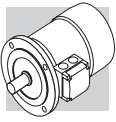

(F 55)

	Rated locking torque	Max. locking torque	Release speed
	[Nm]	[Nm]	[min <sup>-1</sup> ]
<b>M1</b>	6	10	750
<b>M2</b>	16	27	650
<b>M3</b>	54	92	520
<b>M4</b>	110	205	430

(F 56)

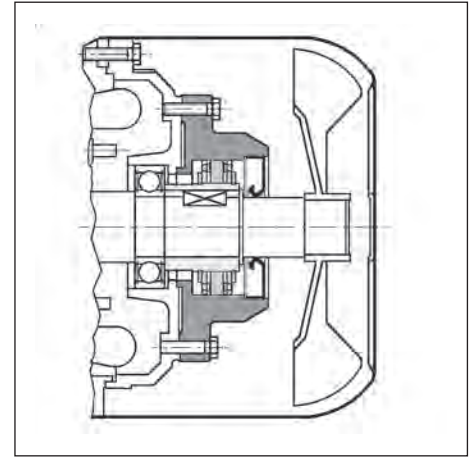

## M9.12 Ventilation

Motors are cooled through outer air blow (IC 411 according to CEI EN 60034-6) and are equipped with a plastic radial fan, which operates in both directions.

Ensure that fan cover is installed at a suitable distance from the closest wall so to allow air circulation and servicing of motor and brake, if fitted.



On request, motors can be supplied with independently power-supplied forced ventilation system starting from BN 71 or M1 size.

Motor is cooled by an axial fan with independent power supply and fitted on the fan cover (IC 416 cooling system).

This version is used in case of motor driven by inverter so that steady torque operation is possible even at low speed or when high starting frequencies are needed.



Brake all motors with rear shaft projection (PS option) are excluded.

(F 57)

Power supply					
		V a.c. ± 10%	Hz	P [W]	I [A]
<b>BN 71</b>	<b>M1</b>	1~ 230	50 / 60	22	0.12
<b>BN 80</b>	<b>M2</b>			22	0.12
<b>BN 90</b>	—			40	0.30
<b>BN 100 (*)</b>	<b>M3</b>			50	0.25
<b>BN 112</b>	—	3~ 230 Δ / 400Y	50	50	0.26 / 0.15
<b>BN 132S</b>	<b>M4S</b>			110	0.38 / 0.22
<b>BN 132M...BN 160MR</b>	<b>M4L</b>				
<b>BN 160...BN 180M</b>	<b>M5</b>			180	1.25 / 0.72

This variant has two different models, called **U1** and **U2**, having the same longitudinal size. Longer side of fan cover (**DL**) is specified for both models in the table below. Overall dimension can be reckoned from motor size table.

(F 58)

Extra length for servoventilated motors			
		$\Delta L_1$	$\Delta L_2$
<b>BN 71</b>	<b>M1</b>	93	32
<b>BN 80</b>	<b>M2</b>	127	55
<b>BN 90</b>	—	131	48
<b>BN 100</b>	<b>M3</b>	119	28
<b>BN 112</b>	—	130	31
<b>BN 132S</b>	<b>M4S</b>	161	51
<b>BN 132M</b>	<b>M4L</b>	161	51

$\Delta L_1$  = extra length to LB value of corresponding standard motor

$\Delta L_2$  = extra length to LB value of corresponding brake motor

**U1**



Fan wiring terminals are housed in a separate terminal box.

In brake motors of size BN 71...BN 160MR, M1...M4L, with **U1** model, the release lever cannot be positioned to AA.

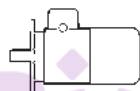

The option is not applicable to motors compliant with the CSA and UL norms (option CUS).

**U2**



Fan terminals are wired in the motor terminal box. The **U2** option does not apply to motors BN 160 through BN 200L, M5, with the only exception of motor BN 160MR for which the option is available instead and to motors with option CUS (compliant to norms CSA and UL).

(F 59)

		V a.c. $\pm 10\%$	Hz	P [W]	I [A]
<b>BN 71</b>	<b>M1</b>	1 ~ 230	50 / 60	22	0.12
<b>BN 80</b>	<b>M2</b>			22	0.12
<b>BN 90</b>	—			40	0.30
<b>BN 100</b>	<b>M3</b>	3 ~ 230 $\Delta$ / 400Y		40	0.26 / 0.09
<b>BN 112</b>	—			50	0.26 / 0.15
<b>BN 132 ... BN 160MR</b>	<b>M4L</b>			110	0.38 / 0.22

### M9.13 Rain canopy

**RC**

The rain canopy protects the motor from dripping and avoids the ingress of solid bodies. It is recommended when motor is installed in a vertical position with the shaft downwards.



Relevant dimensions are indicated in the table below.

The drip cover is not compatible with variants PS, EN1, EN2, EN3, EN4, EN5, EN6.

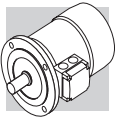

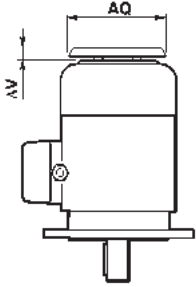

(F 60)

		AQ	$\Delta V$	
BN 63	M05	118	24	
BN 71	M1	134	27	
BN 80	M2	152	25	
BN 90	—	168	30	
BN 100	M3	190	28	
BN 112	—	211	32	
BN 132...BN 160MR	M4	254	32	
BN 160M...BN 180M	M5	302	36	
BN 180L...BN 200L	—	340	36	

#### M9.14 Textile canopy

##### TC

Option TC is a cover variant for textile industry environments, where lint may obstruct the fan grid and prevent a regular flow of cooling air.

This option is not compatible with variants EN1, EN2, EN3, EN4, EN5, EN6.

Overall dimensions are the same as drip cover type RC.

#### M9.15 Feedback units

Motors may be combined with six different types of encoders to achieve feedback circuits.

Configurations with double-extended shaft (PS) and rain canopy (RC, TC) are not compatible with encoder installation.

##### EN1

Incremental encoder,  $V_{IN} = 5$  V, line-driver output RS 422.

##### EN2

Incremental encoder,  $V_{IN} = 10-30$  V, line-driver output RS 422.

##### EN3

Incremental encoder,  $V_{IN} = 12-30$  V, push-pull output 12-30 V

## EN4

Encoder sin/cos,  $V_{IN} = 4.5-5.5$  V, output Sinus  $0.5V_{PP}$ .

## EN5

Absolute encoder singleturn, HIPERFACE® interface,  $V_{IN} = 7-12$  V.

## EN6

Absolute encoder multiturn, HIPERFACE® interface,  $V_{IN} = 7-12$  V.

(F 61)

	EN1	EN2	EN3	EN4	EN5	EN6
Interface	TTL/RS 422	TTL/RS 422	HTL/push-pull	Sinus 0.5 VPP	HIPERFACE®	HIPERFACE®
Power supply voltage [V]	4...6	10...30	12...30	4.4...5.5	7...12	7...12
Output voltage [V]	5	5	12...30	—	—	—
No-load operating current [mA]	120	100	100	40	80	80
No. of pulses per revolution	1024					
Steps per revolution	—	—	—	—	15 bit	15 bit
Revolutions	—	—	—	—	—	12 bit
No. of signals	6 (A, B, Z + inverted signals)			6 (cos-, cos+, sin-, sin+, Z, Z)	—	—
Max. output frequency [kHz]	600			200		
Max. speed [min <sup>-1</sup> ]	6000 (9000 min <sup>-1</sup> for 10 s)					
Working temperature range [°C]	-30 ... +100					
Protection class	IP 65					

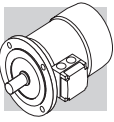

(F 63)

EN1, EN2, EN3, EN4, EN5, EN6	
BN 63...BN 200L	M05...M5
BN 63_FD...BN 200L_FD	M05_FD...M5_FD
BN 63_FA...BN 200L_FA	M05_FA...M5_FA

(F 62)

EN_ + U1		
BN 160M...BN 180M	M5	L3 72
BN 180L...BN 200L	-	82
BN 160M_FD...BN 180M_FD	M5_FD	35
BN 180L_FD...BN 200L_FD	-	41

If the encoder device (option EN\_) is specified on motors BN71...BN160MR / M1...M4, along with the independent fan cooling (options U1, U2), the extra length of motor is coincident with that of the correspondent U1 and U2 execution.

## M9.16 Surface protection

**C\_**

When no specific protection class is requested, the painted (ferrous) surfaces of motors are protected to at least corrosivity class C2 (UNI EN ISO 12944-2). For improved resistance to atmospheric corrosion, motors can be delivered with C3 and C4 surface protection.

SURFACE PROTECTION	Typical environments	Maximum surface temperature	Corrosivity class according to UNI EN ISO 12944-2
<b>C3</b>	Urban and industrial environments with up to 100% relative humidity (medium air pollution)	120°C	C3
<b>C4</b>	Industrial areas, coastal areas, chemical plant, with up to 100% relative humidity (high air pollution)	120°C	C4

Motors with optional protection to class C3 or C4 are available in a choice of colours. If no specific colour is requested (see the “PAINTING” option) motors are finished in RAL 7042.

Motors can also be supplied with surface protection for corrosivity class C5 according to UNI EN ISO 12944-2. Contact our Technical Service for further details.

## M9.17 Painting

**RAL\_**

Gearboxes with optional protection to class C3 or C4 are available in the colours listed in the following table.

PAINTING	Colour	RAL number
<b>RAL7042*</b>	Traffic Grey A	7042
<b>RAL5010</b>	Gentian Blue	5010
<b>RAL9005</b>	Jet Black	9005
<b>RAL9006</b>	White Aluminium	9006
<b>RAL9010</b>	Pure White	9010

\* Gearboxes are supplied in this standard colour if no other colour is specified.

NOTE – “PAINTING” options can only be specified in conjunction with “SURFACE PROTECTION” options.

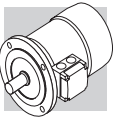

## M9.18 Certificates

### ACM

#### Certificate of compliance of motors

The document certifies the compliance of the product with the purchase order and the construction in conformity with the applicable procedures of the Bonfiglioli Quality System.

### CC





#### Inspection certificate

The document entails checking on order compliance, the visual inspection of external conditions and instrumental testing of the electrical characteristics in unloaded conditions. Units inspected are sampled within the shipping batch and marked individually.

آتور صنعت  
ATOORSANAT



M10 MOTOR RATING CHARTS



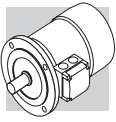

2P		3000 min <sup>-1</sup> - S1																										
		50 Hz																										
		d.c. brake								a.c. brake																		
P <sub>n</sub> kW		n min <sup>-1</sup>	M <sub>n</sub> Nm	IE1	η (100%) %	η (75%) %	η (50%) %	cosφ	I <sub>n</sub> 400V A	I <sub>s</sub> I <sub>n</sub>	I <sub>Ms</sub> I <sub>Mn</sub>	I <sub>Ma</sub> I <sub>Mn</sub>	J <sub>m</sub> x 10 <sup>-4</sup> kgm <sup>2</sup>	IM B5 	FD				FA									
															Mod	Mb Nm	Z <sub>0</sub> 1/h	NB	SB	J <sub>m</sub> x 10 <sup>-4</sup> kgm <sup>2</sup>	IM B5 	Mod	Mb Nm	Z <sub>0</sub> 1/h	J <sub>m</sub> x 10 <sup>-4</sup> kgm <sup>2</sup>	IM B5 		
0.18	BN 63A	2	2730	0.63	○	59.9	56.9	51.9	0.77	0.56	3.0	2.1	2.0	2.0	3.5	FD 02	1.75	3900	4800	4800	2.6	5.2	FA 02	1.75	4800	4800	2.6	5.0
0.25	BN 63B	2	2740	0.87	○	66.0	64.8	64.8	0.76	0.72	3.3	2.3	2.3	2.3	3.9	FD 02	1.75	3900	4800	4800	3.0	5.6	FA 02	1.75	4800	4800	3.0	5.4
0.37	BN 63C	2	2800	1.26	○	69.1	66.8	66.8	0.78	0.99	3.9	2.6	2.6	3.3	5.1	FD 02	3.5	3600	4500	4500	3.9	6.8	FA 02	3.5	4500	4500	3.9	6.6
0.37	BN 71A	2	2820	1.25	○	73.8	73.0	70.6	0.76	0.95	4.8	2.8	2.6	3.5	5.4	FD 03	3.5	3000	4100	4100	4.6	8.1	FA 03	3.5	4200	4200	4.6	7.8
0.55	BN 71B	2	2820	1.86	○	76.0	75.8	74.8	0.76	1.37	5.0	2.9	2.8	4.1	6.2	FD 03	5	2900	4200	4200	5.3	8.9	FA 03	5	4200	4200	5.3	8.6
0.75	BN 71C	2	2810	2.6	○	76.6	76.2	76.2	0.76	1.86	5.1	3.1	2.8	5.0	7.3	FD 03	5	1900	3300	3300	6.1	10.0	FA 03	5	3600	3600	6.1	9.7
0.75	BN 80A	2	2810	2.6	●	76.2	75.5	66.3	0.81	1.75	4.8	2.6	2.2	7.8	8.6	FD 04	5	1700	3200	3200	9.4	12.5	FA 04	5	3200	3200	9.4	12.4
1.1	BN 80B	2	2800	3.8	●	76.4	76.2	75.0	0.81	2.57	4.8	2.8	2.4	9.0	9.5	FD 04	10	1500	3000	3000	10.6	13.4	FA 04	10	3000	3000	10.6	13.3
1.5	BN 80C	2	2800	5.1	●	79.1	79.5	77.2	0.81	3.4	4.9	2.7	2.4	11.4	11.3	FD 04	15	1300	2600	2600	13.0	15.2	FA 04	15	2600	2600	13.0	15.1
1.5	BN 90SA	2	2870	5.0	●	82.0	81.5	78.1	0.80	3.4	5.9	2.7	2.6	12.5	12.3	FD 14	15	900	2200	2200	14.1	16.5	FA 14	15	2200	2200	14.1	16.4
1.85	BN 90SB	2	2880	6.1	●	82.5	82.0	75.4	0.80	4.0	6.2	2.9	2.6	16.7	14	FD 14	15	900	2200	2200	18.3	18.2	FA 14	15	2200	2200	18.3	18.1
2.2	BN 90L	2	2880	7.3	●	82.7	82.1	80.8	0.80	4.8	6.3	2.9	2.7	16.7	14	FD 05	26	900	2200	2200	21	20	FA 05	26	2200	2200	21	20.7
3	BN 100L	2	2860	10.0	●	81.5	81.3	77.4	0.79	6.7	5.6	2.6	2.2	31	20	FD 15	26	700	1600	1600	35	26	FA 15	26	1600	1600	35	27
4	BN 100LB	2	2870	13.3	●	83.1	83.0	77.8	0.80	8.7	5.8	2.7	2.5	39	23	FD 15	40	450	900	900	43	29	FA 15	40	1000	1000	43	30
4	BN 112M	2	2900	13.2	●	85.5	84.5	83.0	0.82	8.2	6.9	3.0	2.9	57	28	FD 06S	40	—	950	950	66	39	FA 06S	40	950	950	66	40
5.5	BN 132SA	2	2890	18.2	●	84.7	84.5	81.2	0.84	11.2	5.9	2.6	2.2	101	35	FD 06	50	—	600	600	112	48	FA 06	50	600	600	112	49
7.5	BN 132SB	2	2900	25	●	86.5	86.3	84.4	0.85	14.7	6.4	2.6	2.2	145	42	FD 06	50	—	550	550	154	55	FA 06	50	550	550	154	56
9.2	BN 132M	2	2930	30	●	87.0	86.5	83.6	0.86	17.7	6.7	2.8	2.3	178	53	FD 06	75	—	430	430	189	66	FA 06	75	430	430	189	67
11	BN 160MR	2	2920	36	●	87.6	87.0	86.0	0.88	20.6	6.9	2.9	2.5	210	65	FD 06	50	—	—	—	66	39	FA 06S	40	950	950	66	40
15	BN 160MB	2	2930	49	●	89.6	89.4	88.0	0.86	28.1	7.1	2.6	2.3	340	84	FD 06	50	—	—	—	112	48	FA 06	50	600	600	112	49
18.5	BN 160L	2	2930	60	●	90.4	90.1	89.0	0.86	34	7.6	2.7	2.3	420	97	FD 06	75	—	—	—	154	55	FA 06	50	550	550	154	56
22	BN 180M	2	2930	72	●	89.9	89.7	89.5	0.88	40	7.8	2.6	2.4	490	109	FD 06	75	—	—	—	189	66	FA 06	75	430	430	189	67
30	BN 200LA	2	2930	98	●	90.7	90.1	87.6	0.89	54	7.8	2.7	2.9	770	140	FD 06	75	—	—	—	189	66	FA 06	75	430	430	189	67

○ = n.a. ● = IE1



4P		1500 min <sup>-1</sup> - S1														50 Hz									
		d.c. brake														a.c. brake									
		P <sub>n</sub> kW	n min <sup>-1</sup>	M <sub>n</sub> Nm	IE1	η (100%) %	η (75%) %	η (50%) %	cosφ	In 400V A	Is In A	Ms Mn	Ma Mn	J <sub>m</sub> x 10 <sup>-4</sup> kgm <sup>2</sup>	IM B5	Mod	Mb Nm	Z <sub>0</sub> 1/h	NB	SB	J <sub>m</sub> x 10 <sup>-4</sup> kgm <sup>2</sup>	IM B5	Mod	Mb Nm	Z <sub>0</sub> 1/h
FA	FA																								
0.06	4	0.43	○	46.8	44.2	41.3	0.65	0.28	2.6	2.3	2.0	1.5	3.1	FD 02	1.75	10000	13000	2.6	5.2	FA 02	1.75	13000	2.6	5.2	IM B5
0.09	4	0.64	○	51.7	47.6	42.9	0.60	0.42	2.6	2.5	2.4	1.5	3.1	FD 02	3.5	10000	13000	3.0	5.6	FA 02	3.5	13000	3.0	5.6	IM B5
0.12	4	0.85	○	59.8	56.2	47.0	0.62	0.47	2.6	1.9	1.8	2.0	3.5	FD 02	3.5	7800	10000	3.9	6.8	FA 02	3.5	10000	3.9	6.8	IM B5
0.18	4	1.30	○	54.8	52.9	52.5	0.67	0.71	2.6	2.2	2.0	2.3	3.9	FD 03	5	6000	9400	8.0	8.6	FA 03	5	9400	8.0	8.6	IM B5
0.25	4	1.78	○	65.3	65.0	57.9	0.69	0.80	2.7	2.1	1.9	3.3	5.1	FD 53	7.5	4300	8700	10.2	10.0	FA 03	7.5	8700	10.2	10.0	IM B5
0.25	4	1.73	○	63.7	62.2	59.1	0.73	0.78	3.3	1.9	1.7	5.8	5.1	FD 03	3.5	7700	11000	6.9	7.8	FA 03	3.5	11000	6.9	7.8	IM B5
0.37	4	2.6	○	66.8	66.7	63.0	0.76	1.05	3.7	2.0	1.9	6.9	5.9	FD 03	5	6000	9400	8.0	8.6	FA 03	5	9400	8.0	8.6	IM B5
0.55	4	3.8	○	69.0	68.9	68.8	0.74	1.55	4.1	2.3	2.3	9.1	7.3	FD 53	7.5	4300	8700	10.2	10.0	FA 03	7.5	8700	10.2	10.0	IM B5
0.55	4	3.8	○	72.0	71.3	69.7	0.77	1.43	4.1	2.3	2.0	15	8.2	FD 04	10	4100	8000	16.6	12.1	FA 04	10	8000	16.6	12.1	IM B5
0.75	4	5.1	●	75.0	74.5	69.3	0.78	1.85	4.9	2.7	2.5	20	9.9	FD 04	15	4100	7800	22	13.8	FA 04	15	7800	22	13.8	IM B5
1.1	4	7.5	●	75.5	76.2	70.4	0.78	2.7	5.1	2.8	2.5	25	11.3	FD 04	15	2600	5300	27	15.2	FA 04	15	5300	27	15.1	IM B5
1.1	4	7.6	●	76.5	76.2	72.2	0.77	2.70	4.6	2.6	2.2	21	12.2	FD 14	15	4800	8000	23	16.4	FA 14	15	8000	23	16.3	IM B5
1.5	4	10.2	●	78.7	78.5	74.9	0.77	3.6	5.3	2.8	2.4	28	13.6	FD 05	26	3400	6000	32	19.6	FA 05	26	6000	32	20.3	IM B5
1.85	4	12.7	●	78.6	78.9	77.2	0.79	4.3	5.1	2.8	2.6	30	15.1	FD 05	26	3200	5900	34	21.1	FA 05	26	5900	34	21.8	IM B5
2.2	4	14.9	●	81.1	81.4	79.9	0.75	5.2	4.5	2.2	2.0	40	18	FD 15	40	2600	4700	44	25	FA 15	40	4700	44	25	IM B5
3	4	20	●	82.6	83.8	83.7	0.77	6.8	5.0	2.3	2.2	54	22	FD 15	40	2400	4400	58	28	FA 15	40	4400	58	29	IM B5
4	4	27	●	84.4	84.2	81.6	0.81	8.4	5.6	2.7	2.5	98	30	FD 06S	60	—	1400	107	40	FA 06S	60	2100	107	42	IM B5
5.5	4	36	●	84.7	84.8	82.5	0.81	11.6	5.5	2.3	2.2	213	44	FD 56	75	—	1050	223	57	FA 06	75	1200	223	58	IM B5
7.5	4	50	●	86.0	86.3	85.3	0.81	15.5	5.7	2.5	2.4	270	53	FD 06	100	—	950	280	66	FA 07	100	1000	280	71	IM B5
9.2	4	61	●	88.4	88.6	87.5	0.81	18.8	5.9	2.7	2.5	319	59	FD 07	150	—	900	342	75	FA 07	150	900	342	77	IM B5
11	4	73	●	87.6	87.8	86.0	0.81	22.4	6.0	2.7	2.5	360	70	FD 07	150	—	850	382	86	FA 07	150	850	382	88	IM B5
15	4	98	●	88.7	88.5	88.4	0.81	30	6.0	2.3	2.1	650	99	FD 08	200	—	750	725	129	FA 08	200	750	710	128	IM B5
18.5	4	121	●	89.3	89.5	89.2	0.81	37	6.2	2.6	2.5	790	115	FD 08	250	—	700	865	145	FA 08	250	700	850	144	IM B5
22	4	144	●	89.9	90.0	90.0	0.80	44	6.4	2.5	2.5	1250	135	FD 09	300	—	400	1450	175	FA 08	300	700	850	144	IM B5
30	4	196	●	91.4	91.7	91.0	0.80	59	7.1	2.7	2.8	1650	157	FD 09	400	—	300	1850	197	FA 08	400	700	850	144	IM B5

○ = n.a. ● = IE1

P <sub>n</sub> kW		n min <sup>-1</sup>	M <sub>n</sub> Nm	IE1	η (100%) %	η (75%) %	η (50%) %	cosφ	In 400V A	Is In A	Ms Mn	Ma Mn	J <sub>m</sub> x 10 <sup>-4</sup> kgm <sup>2</sup>	IM B5 	d.c. brake				a.c. brake											
															FD		FA		FD		FA									
															Mod	Mb Nm	Z <sub>0</sub> 1/h	NB	SB	Mod	Mb Nm	Z <sub>0</sub> 1/h	IM B5 	J <sub>m</sub> x 10 <sup>-4</sup> kgm <sup>2</sup>	Mod	Mb Nm	Z <sub>0</sub> 1/h	IM B5 	J <sub>m</sub> x 10 <sup>-4</sup> kgm <sup>2</sup>	
0.09	BN 63A	6	0.98	○	41.0	41.0	32.9	0.53	0.60	2.1	2.1	1.8	3.4	4.6	FD 02	3.5	9000	14000	9000	14000	FA 02	3.5	14000	6.3	4.0	FA 02	3.5	14000	6.1	4.0
0.12	BN 63B	6	1.32	○	45.0	44.0	41.8	0.60	0.64	2.1	1.9	1.7	3.7	4.9	FD 02	3.5	9000	14000	9000	14000	FA 02	3.5	14000	6.6	4.3	FA 02	3.5	14000	6.4	4.3
0.18	BN 71A	6	1.91	○	55.0	55.5	51.0	0.69	0.88	2.6	1.9	1.7	8.4	5.5	FD 03	5	8100	13500	8100	13500	FA 03	5	13500	8.2	9.5	FA 03	5	13500	7.9	9.5
0.25	BN 71B	6	2.70	○	62.0	58.5	51.4	0.71	0.82	2.6	1.9	1.7	10.9	6.7	FD 03	5	7800	13000	7800	13000	FA 03	5	13000	9.4	12	FA 03	5	13000	9.1	12
0.37	BN 71C	6	3.9	○	66.0	60.0	53.3	0.69	1.17	3.0	2.4	2.0	12.9	7.7	FD 53	7.5	5100	9500	5100	9500	FA 03	7.5	9500	10.4	14	FA 03	7.5	9500	10.1	14
0.37	BN 80A	6	3.9	○	68.0	67.4	63.3	0.68	1.15	3.2	2.2	2.0	21	9.9	FD 04	10	5200	8500	5200	8500	FA 04	10	8500	13.8	23	FA 04	10	8500	13.7	23
0.55	BN 80B	6	5.7	○	70.0	69.8	64.3	0.68	1.67	3.9	2.6	2.2	25	11.3	FD 04	15	4800	7200	4800	7200	FA 04	15	7200	15.2	27	FA 04	15	7200	15.1	27
0.75	BN 80C	6	7.8	●	70.0	70.0	64.4	0.65	2.38	3.8	2.5	2.2	28	12.2	FD 04	15	3400	6400	3400	6400	FA 04	15	6400	16.1	30	FA 04	15	6400	16.0	30
0.75	BN 90S	6	7.8	●	70.0	69.0	64.2	0.68	2.27	3.8	2.4	2.2	26	12.6	FD 14	15	3400	6500	3400	6500	FA 14	15	6500	16.8	28	FA 14	15	6500	16.7	28
1.1	BN 90L	6	11.4	●	72.9	72.6	69.1	0.69	3.2	3.9	2.3	2.0	33	15	FD 05	26	2700	5000	2700	5000	FA 05	26	5000	21	37	FA 05	26	5000	22	37
1.5	BN 100LA	6	15.2	●	75.2	74.2	70.3	0.72	4.0	4.1	2.1	2.0	82	22	FD 15	40	1900	4100	1900	4100	FA 15	40	4100	28	86	FA 15	40	4100	29	86
1.85	BN 100LB	6	19.0	●	76.6	72.8	62.6	0.73	4.8	4.6	2.1	2.0	95	24	FD 15	40	1700	3600	1700	3600	FA 15	40	3600	30	99	FA 15	40	3600	31	99
2.2	BN 112M	6	22	●	78.5	79.0	76.5	0.73	5.5	4.8	2.2	2.0	168	32	FD 06S	60	—	2100	—	2100	FA 06S	60	2100	42	177	FA 06S	60	2100	44	177
3	BN 132S	6	30	●	79.7	77.0	75.1	0.76	7.1	5.1	1.9	1.8	216	36	FD 56	75	—	1400	—	1400	FA 06	75	1400	49	226	FA 06	75	1400	50	226
4	BN 132MA	6	40	●	81.4	81.5	79.5	0.77	9.2	5.5	2.0	1.8	295	45	FD 06	100	—	1200	—	1200	FA 07	100	1200	58	305	FA 07	100	1200	63	318
5.5	BN 132MB	6	56	●	83.1	80.9	79.1	0.78	12.2	6.1	2.1	1.9	383	56	FD 07	150	—	1050	—	1050	FA 07	150	1050	72	406	FA 07	150	1050	74	406
7.5	BN 160M	6	75	●	85.0	85.0	84.8	0.81	15.7	5.9	2.2	2.0	740	83	FD 08	170	—	900	—	900	FA 08	170	900	112	815	FA 08	170	900	113	815
11	BN 160L	6	109	●	86.4	86.5	85.9	0.81	22.7	6.6	2.5	2.3	970	103	FD 08	200	—	800	—	800	FA 08	200	800	133	1045	FA 08	200	800	133	1045
15	BN 180L	6	148	●	87.7	88.0	87.3	0.82	30	6.2	2.0	2.4	1550	130	FD 09	300	—	600	—	600	FA 09	300	600	170	1750	FA 09	300	600	170	1750
18.5	BN 200LA	6	184	●	88.6	88.0	87.3	0.81	37	5.9	2.0	2.3	1700	145	FD 09	400	—	450	—	450	FA 09	400	450	185	1900	FA 09	400	450	185	1900

○ = n.a. ● = IE1

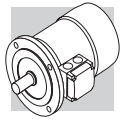



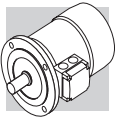



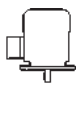

8P		750 min-1 - S1														50 Hz							
		d.c. brake														a.c. brake							
		P <sub>n</sub> kW	Image	n min <sup>-1</sup>	M <sub>n</sub> Nm	η %	cosφ	I <sub>n</sub> 400V A	I <sub>s</sub> I <sub>n</sub>	M <sub>s</sub> M <sub>n</sub>	M <sub>a</sub> M <sub>n</sub>	J <sub>m</sub> x 10 <sup>-4</sup> kgm <sup>2</sup>	IM B5 Image	Mod	Mb Nm	NB	SB	Z <sub>0</sub> 1/h	J <sub>m</sub> x 10 <sup>-4</sup> kgm <sup>2</sup>	IM B5 Image	Mod	Mb Nm	Z <sub>0</sub> 1/h
FA	FA																						
0.09	BN 71A	8	1.26	47	0.59	0.47	2.3	2.4	2.3	10.9	6.7	FD 03	3.5	9000	16000	16000	9.4	FA 03	3.5	16000	12.0	9.1	
0.12	BN 71B	8	1.69	51	0.59	0.58	2.1	2.3	2.2	12.9	7.7	FD 03	5.0	9000	16000	16000	10.4	FA 03	5.0	16000	14.0	10.1	
0.18	BN 80A	8	2.49	51	0.60	0.85	2.4	2.2	2.2	15	8.2	FD 04	5.0	6500	11000	11000	12.1	FA 04	5.0	11000	16.6	12.0	
0.25	BN 80B	8	3.51	54	0.63	1.06	2.4	2.0	1.9	20	9.9	FD 04	10.0	6000	10000	10000	13.8	FA 04	10.0	10000	23	13.7	
0.37	BN 90S	8	5.2	58	0.60	1.53	2.6	2.3	2.1	26	12.6	FD 14	15.0	4800	7500	7500	16.8	FA 14	15.0	7500	28	16.7	
0.55	BN 90L	8	7.8	62	0.60	2.13	2.6	2.2	2.0	33	15	FD 05	26	4000	6400	6400	21	FA 05	26	6400	37	22	
0.75	BN 100LA	8	10.2	68	0.63	2.53	3.4	1.9	1.7	82	22	FD 15	26	2800	4800	4800	28	FA 15	26	4800	86	29	
1.1	BN 100LB	8	15.0	68	0.64	3.65	3.2	1.7	1.7	95	24	FD 15	40	2500	4000	4000	30	FA 15	40	4000	99	31	
1.5	BN 112M	8	20.2	71	0.66	4.6	3.7	1.8	1.9	168	32	FD 06S	60	—	3000	3000	42	FA 06S	60	3000	177	44	
2.2	BN 132S	8	29.6	75	0.66	6.4	3.8	1.8	2.0	295	45	FD 56	75	—	2300	2300	58	FA 06	75	2300	305	56	
3	BN 132MA	8	40.4	76	0.69	8.3	3.9	1.6	1.8	370	53	FD 06	100	—	1900	1900	69	FA 07	100	1900	406	74	

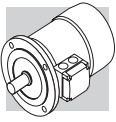

2/4P		3000/1500 min <sup>-1</sup> - S1														50 Hz													
		d.c. brake														a.c. brake													
		FD							FA							FD							FA						
P <sub>n</sub>		n	M <sub>n</sub>	η	cos φ	I <sub>n</sub>	I <sub>s</sub>	$\frac{I_s}{I_n}$	$\frac{M_s}{M_n}$	$\frac{M_a}{M_n}$	J <sub>m</sub>	IM B5	Mod	Mb	Z <sub>0</sub>	J <sub>m</sub>	IM B5	Mod	Mb	Z <sub>0</sub>	J <sub>m</sub>	IM B5							
kW		min <sup>-1</sup>	Nm	%		A	A				kgm <sup>2</sup>	kgm <sup>2</sup>		Nm	1/h	kgm <sup>2</sup>	kgm <sup>2</sup>		Nm	1/h	kgm <sup>2</sup>	kgm <sup>2</sup>							
0.20	BN 63B	2	0.71	55	0.82	0.64	3.5	2.1	1.9	1.9	2.9	4.4	FD 02	3.5	2200	2600	3.5	6.1	FA 02	3.5	2600	3.5	5.9						
0.15		4	1.350	49	0.67	0.66	2.6	1.8	1.7	1.7	4.4			3.5	4000	5100	3.5			3.5	5100								
0.28	BN 71A	2	0.99	56	0.82	0.88	2.9	1.9	1.7	1.7	4.7	4.4	FD 03	3.5	2100	2400	5.8	7.1	FA 03	3.5	2400	5.8	6.8						
0.20		4	1.370	59	0.72	0.68	3.1	1.8	1.7	1.7	5.8			5.0	3800	4800	6.9			5.0	4800	6.9	7.5						
0.37	BN 71B	2	1.29	56	0.82	1.16	3.5	1.8	1.8	1.8	5.8	5.1	FD 03	5.0	1400	2100	6.9	7.8	FA 03	5.0	2100	6.9	7.5						
0.25		4	1.390	60	0.73	0.82	3.3	2.0	1.9	1.9	6.9			5.0	2900	4200	8.0			5.0	4200	8.0	8.3						
0.45	BN 71C	2	1.55	63	0.85	1.21	3.8	1.8	1.8	1.8	6.9	5.9	FD 03	5.0	1400	2100	8.0	8.6	FA 03	5.0	2100	8.0	8.3						
0.30		4	1.400	63	0.73	0.94	3.6	2.0	1.9	1.9	6.9			5.0	2800	4200	8.0			5.0	4200	8.0	8.3						
0.55	BN 80A	2	1.9	63	0.85	1.48	3.9	1.7	1.7	1.7	15	8.2	FD 04	5.0	1600	2300	17	12.1	FA 04	5.0	2300	17	12.0						
0.37		4	1.400	67	0.79	1.01	4.1	1.8	1.9	1.9	20			10	3000	4000	22			10	4000	22	13.7						
0.75	BN 80B	2	2.6	65	0.85	1.96	3.8	1.9	1.8	1.8	20	9.9	FD 04	10	1400	1600	22	13.8	FA 04	10	1600	22	13.7						
0.55		4	1.400	68	0.81	1.44	3.9	1.7	1.7	1.7	28			26	1050	1200	32			26	2000	32	21						
1.1	BN 90S	2	3.8	71	0.82	2.73	4.7	2.3	2.0	2.0	21	12.2	FD 14	10	1500	1600	23	16.4	FA 14	10	1600	23	16.3						
0.75		4	1.390	66	0.79	2.08	4.6	2.4	2.2	2.2	28			26	2300	2800	32			26	2800	32	21						
1.5	BN 90L	2	5.2	70	0.85	3.64	4.5	2.4	2.1	2.1	28	14.0	FD 05	26	1050	1200	32	20	FA 05	26	1200	32	21						
1.1		4	1.390	73	0.81	2.69	4.7	2.5	2.2	2.2	28			26	1600	2000	32			26	2000	32	21						
2.2	BN 100LA	2	7.5	72	0.85	5.2	4.5	2.0	1.9	1.9	40	18.3	FD 15	26	600	900	44	25	FA 15	26	900	44	25						
1.5		4	1.410	73	0.79	3.8	4.7	2.0	2.0	2.0	61			40	1300	2300	65			40	2300	65	32						
3.5	BN 100LB	2	11.7	80	0.84	7.5	5.4	2.2	2.1	2.1	61	25	FD 15	40	500	900	65	31	FA 15	40	900	65	32						
2.5		4	1.420	82	0.80	5.5	5.2	2.2	2.2	2.2	61			40	1000	2100	65			40	2100	65	32						
4	BN 112M	2	13.3	79	0.83	8.8	6.1	2.4	2.0	2.0	98	30	FD 06S	60	—	700	107	40	FA 06S	60	700	107	42						
3.3		4	1.420	80	0.80	7.4	5.1	2.1	2.0	2.0	98			60	—	1200	107			60	1200	107	42						
5.5	BN 132S	2	18.2	80	0.87	11.4	5.9	2.4	2.0	2.0	213	44	FD 56	75	—	350	223	57	FA 06	75	350	223	58						
4.4		4	1.440	82	0.84	9.2	5.3	2.2	2.0	2.0	213			75	—	900	223			75	900	223	58						
7.5	BN 132MA	2	25	82	0.87	15.2	6.5	2.4	2.0	2.0	270	53	FD 06	100	—	350	280	66	FA 07	100	350	280	71						
6		4	1.430	84	0.85	12.1	5.8	2.3	2.1	2.1	319			100	—	900	280			100	900	280	71						
9.2	BN 132MB	2	30	83	0.86	18.6	6.0	2.6	2.2	2.2	319	59	FD 07	150	—	300	342	75	FA 07	150	300	342	77						
7.3		4	1.440	85	0.85	14.6	5.5	2.3	2.1	2.1	319			150	—	800	342			150	800	342	77						





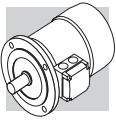

2/6P		3000/1000 min-1 - S3 60/40%														50 Hz								
		d.c. brake														a.c. brake								
		FD							FA															
P <sub>n</sub> kW		n min <sup>-1</sup>	M <sub>n</sub> Nm	η %	cosφ	I <sub>n</sub> 400V A	$\frac{I_s}{I_n}$	$\frac{M_s}{M_n}$	$\frac{M_a}{M_n}$	J <sub>m</sub> x 10 <sup>-4</sup> kgm <sup>2</sup>	IM B5 	Mod	Mb Nm	Z <sub>o</sub> 1/h	NB	SB	J <sub>m</sub> x 10 <sup>-4</sup> kgm <sup>2</sup>	IM B5 	Mod	Mb Nm	Z <sub>o</sub> 1/h	J <sub>m</sub> x 10 <sup>-4</sup> kgm <sup>2</sup>	IM B5 	
0.25	BN 71A	2	0.84	60	0.82	0.73	4.3	1.9	1.8	6.9	5.9	FD 03	1.75	1700	1500	1700	8.0	8.6	FA 03	2.5	1700	13000	8.0	8.3
0.08		6	0.84	43	0.70	0.38	2.1	1.4	1.5					10000	10000	13000								
0.37	BN 71B	2	1.23	62	0.80	1.08	4.4	1.9	1.8	9.1	7.3	FD 03	3.5	1300	1000	1300	10.2	10.0	FA 03	3.5	1300	11000	10.2	9.7
0.12		6	1.27	44	0.73	0.54	2.4	1.4	1.5					9000	9000	11000								
0.55	BN 80A	2	1.88	63	0.86	1.47	4.5	1.9	1.7	20	9.9	FD 04	5.0	1800	1500	1800	22	13.8	FA 04	5.0	1800	6300	22	13.7
0.18		6	1.85	52	0.65	0.77	3.3	2.0	1.9					4100	4100	6300								
0.75	BN 80B	2	2.6	66	0.87	1.89	4.3	1.8	1.6	25	11.3	FD 04	5.0	1700	1700	1900	27	15.2	FA 04	5.0	1900	6000	27	15.1
0.25		6	2.6	54	0.67	1.00	3.2	1.7	1.8					3800	3800	6000								
1.10	BN 90L	2	3.7	67	0.84	2.82	4.7	2.1	1.9	28	14.0	FD 05	13	1400	1400	1600	32	20	FA 05	13	1600	5200	32	21
0.37		6	3.8	59	0.71	1.27	3.3	1.6	1.6					3400	3400	5200								
1.5	BN 100LA	2	5	73	0.84	3.53	5.1	1.9	2.0	40	18.3	FD 15	13	1000	1000	1200	44	24	FA 15	13	1200	4000	44	25
0.55		6	5.6	64	0.67	1.85	3.5	1.7	1.8					2900	2900	4000								
2.2	BN 100LB	2	7.2	77	0.85	4.9	5.9	2.0	2.0	61	25	FD 15	26	700	700	900	65	31	FA 15	26	900	3000	65	32
0.75		6	7.5	67	0.64	2.5	3.3	1.9	1.8					2100	2100	3000								
3	BN 112M	2	9.9	78	0.87	6.4	6.3	2.0	2.1	98	30	FD 06S	40	—	—	—	107	40	FA 06S	40	1000	2600	107	32
1.1		6	11.1	72	0.64	3.4	3.9	1.8	1.8					—	—	—								
4.5	BN 132S	2	14.8	78	0.84	9.9	5.8	1.9	1.8	213	44	FD 66	37	—	—	—	223	57	FA 06	37	500	2100	223	58
1.5		6	14.9	74	0.67	4.4	4.2	1.9	2.0					—	—	—								
5.5	BN 132M	2	18.0	78	0.87	11.7	6.2	2.1	1.9	270	53	FD 66	50	—	—	—	280	66	FA 06	50	400	1900	280	67
2.2		6	22	77	0.71	5.8	4.3	2.1	2.0					—	—	—								

**2/8P** **3000/750 min-1 - S3 60/40%** **50 Hz**

P <sub>n</sub> kW		n min <sup>-1</sup>	M <sub>n</sub> Nm	η %	cosφ	I <sub>n</sub> 400V A	I <sub>s</sub> I <sub>n</sub>	M <sub>s</sub> M <sub>n</sub>	M <sub>a</sub> M <sub>n</sub>	J <sub>m</sub> x 10 <sup>-4</sup> kgm <sup>2</sup>	IM B5 	d.c. brake						a.c. brake							
												FD			FA			FD			FA				
												Mod	Mb Nm	Z <sub>0</sub> 1/h	NB	SB	Mod	Mb Nm	Z <sub>0</sub> 1/h	J <sub>m</sub> x 10 <sup>-4</sup> kgm <sup>2</sup>	IM B5 	Mod	Mb Nm	Z <sub>0</sub> 1/h	J <sub>m</sub> x 10 <sup>-4</sup> kgm <sup>2</sup>
0.25	BN 71A	2	2790	0.86	0.87	0.68	3.9	1.8	1.9	10.9	6.7	FD 03	1.75	1300	1400	1400	1400	12	9.4	FA 03	2.5	1400	1400	12	9.1
0.06		8	680	0.84	0.61	0.46	2.0	1.8	1.9					10000	13000	13000									
0.37	BN 71B	2	2800	1.26	0.86	0.99	3.9	1.8	1.9	12.9	7.7	FD 03	3.5	1200	1300	1300	1300	14	10.4	FA 03	3.5	1300	1300	14	10.1
0.09		8	670	1.28	0.75	0.51	1.8	1.4	1.5					9500	13000	13000									
0.55	BN 80A	2	2830	1.86	0.86	1.40	4.4	2.1	2.0	20	9.9	FD 04	5.0	1500	1800	1800	1800	22	13.8	FA 04	5.0	1800	1800	22	13.7
0.13		8	690	1.80	0.64	0.72	2.3	1.6	1.7					5600	8000	8000									
0.75	BN 80B	2	2800	2.6	0.88	1.81	4.6	2.1	2.0	25	11.3	FD 04	10	1700	1900	1900	1900	27	15.2	FA 04	10	1900	1900	27	15.1
0.18		8	690	2.5	0.66	0.92	2.3	1.6	1.7					4800	7300	7300									
1.10	BN 90L	2	2830	3.7	0.84	3.00	4.5	2.1	1.9	28	14.0	FD 05	13	1400	1600	1600	1600	32	20	FA 05	13	1600	1600	32	21
0.28		8	690	3.9	0.63	1.34	2.4	1.8	1.9					3400	5100	5100									
1.5	BN 100LA	2	2880	5.0	0.85	3.69	4.7	1.9	1.8	40	18.3	FD 15	13	1000	1200	1200	1200	44	25	FA 15	13	1200	1200	44	25
0.37		8	690	5.1	0.63	1.84	2.1	1.6	1.6					3300	5000	5000									
2.4	BN 100LB	2	2900	7.9	0.82	5.6	5.4	2.1	2.0	61	25	FD 15	26	550	700	700	700	65	31	FA 15	26	700	700	65	32
0.55		8	700	7.5	0.58	2.5	2.6	1.8	1.8					2000	3500	3500									
3	BN 112M	2	2900	9.9	0.87	6.5	6.3	2.1	1.9	98	30	FD 06S	40	—	900	900	900	107	40	FA 06S	40	900	900	107	42
0.75		8	690	10.4	0.65	2.8	2.5	1.6	1.6					—	2900	2900									
4	BN 132S	2	2870	13.3	0.84	9.4	5.6	2.3	2.4	213	44	FD 06	37	—	500	500	500	223	57	FA 06	37	500	500	223	58
1		8	690	13.8	0.62	3.5	2.9	1.9	1.8					—	3500	3500									
5.5	BN 132M	2	2870	18.3	0.84	12.6	6.1	2.4	2.5	270	53	FD 06	50	—	400	400	400	280	66	FA 06	50	400	400	280	67
1.5		8	690	21	0.63	5.1	2.9	1.9	1.9					—	2400	2400									





2/12P		3000/500 min-1 - S3 60/40%														50 HZ						
		d.c. brake														a.c. brake						
		FD														FA						
$P_n$		$n$	$M_n$	$\eta$	$\cos\phi$	$I_n$	$\frac{I_s}{I_n}$	$\frac{M_s}{M_n}$	$\frac{M_a}{M_n}$	$J_m$	IM BS	Mod	Mb	$Z_o$	$J_m$	IM B5	Mod	Mb	$Z_o$	$J_m$	IM B5	
kW		min <sup>-1</sup>	Nm	%		A				$\times 10^{-4}$			Nm	1/h	$\times 10^{-4}$			Nm	1/h	$\times 10^{-4}$		
0.55	BN 80B	2	1.86	64	0.89	1.39	4.2	1.6	1.7	25	11.3	FD 04	5.0	1300	27	15.2	FA 04	5.0	1300	27	15.1	15.1
0.09		12	2.0	30	0.63	0.69	1.8	1.9	1.8					8000					12000			
0.75	BN 90L	2	2.6	56	0.89	2.17	4.2	1.8	1.7	26	12.6	FD 05	13	1150	30	18.6	FA 05	13	1150	30	19.3	19.3
0.12		12	2.7	26	0.63	1.06	1.7	1.4	1.6					4600					6300			
1.10	BN 100LA	2	3.7	65	0.85	2.87	4.5	1.6	1.8	40	18.3	FD 15	13	900	44	25	FA 15	13	900	44	25	25
0.18		12	4.0	26	0.54	1.85	1.5	1.3	1.5					4000					6000			
1.5	BN 100LB	2	4.9	67	0.86	3.76	5.6	1.9	1.9	54	22	FD 15	13	900	58	28	FA 15	13	900	58	28	29
0.25		12	5.4	36	0.46	2.18	1.8	1.7	1.8					3800					5000			
2	BN 112M	2	6.6	74	0.88	4.43	6.5	2.1	2.0	98	30	FD 06S	20	800	107	40	FA 06S	20	800	107	40	42
0.3		12	6.2	46	0.43	2.19	2.0	2.1	2.0					3400					3400			
3	BN 132S	2	9.8	74	0.87	6.7	6.8	2.3	1.9	213	44	FD 56	37	450	223	57	FA 06	37	450	223	57	58
0.5		12	10.2	51	0.43	3.3	2.0	1.7	1.6					3000					3000			
4	BN 132M	2	13.1	75	0.89	8.6	5.9	2.4	2.3	270	53	FD 56	37	400	280	66	FA 06	37	400	280	66	67
0.7		12	14.5	53	0.44	4.3	1.9	1.7	1.6					2800					2800			





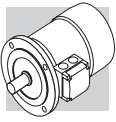

**4/6P** **1500/1000 min<sup>-1</sup> - S1** **50 Hz**

P <sub>n</sub> kW		n min <sup>-1</sup>	M <sub>n</sub> Nm	η %	cosφ	I <sub>n</sub> 400V A	I <sub>s</sub> I <sub>n</sub>	M <sub>s</sub> M <sub>n</sub>	M <sub>a</sub> M <sub>n</sub>	J <sub>m</sub> x 10 <sup>-4</sup> kgm <sup>2</sup>	IM B5 	d.c. brake						a.c. brake					
												FD			FA			FD			FA		
												Mod	Mb Nm	Z <sub>0</sub> 1/h	NB	SB	J <sub>m</sub> x 10 <sup>-4</sup> kgm <sup>2</sup>	IM B5 	Mod	Mb Nm	Z <sub>0</sub> 1/h	J <sub>m</sub> x 10 <sup>-4</sup> kgm <sup>2</sup>	IM B5 
0.22	<b>BN 71B</b>	4	1410	1.5	64	0.74	3.9	1.8	1.9	9.1	7.3	<b>FD 03</b>	3.5	2500	3500	10.2	10.0	<b>FA 03</b>	3.5	3500	10.2	9.7	
0.13		6	920	1.4	43	0.67	2.3	1.6	1.7				5000	9000						9000			
0.30	<b>BN 80A</b>	4	1410	2.0	61	0.82	3.5	1.3	1.5	15	8.2	<b>FD 04</b>	5.0	2500	3100	16.6	12.1	<b>FA 04</b>	5.0	3100	16.6	12.0	
0.20		6	930	2.1	54	0.66	3.2	1.9	2.0				4000	6000						6000			
0.40	<b>BN 80B</b>	4	1430	2.7	63	0.75	3.9	1.8	1.8	20	9.9	<b>FD 04</b>	10	1800	2300	22	13.8	<b>FA 04</b>	10	2300	22	13.7	
0.26		6	930	2.7	55	0.70	2.7	1.5	1.6				3600	5500						5500			
0.55	<b>BN 90S</b>	4	1420	3.7	70	0.78	4.5	2.0	1.9	21	12.2	<b>FD 14</b>	10	1500	2100	23	16.1	<b>FA 14</b>	10	2100	23	16.3	
0.33		6	930	3.4	62	0.70	3.7	2.3	2.0				2500	4100						4100			
0.75	<b>BN 90L</b>	4	1420	5.0	74	0.78	4.3	1.9	1.8	28	14	<b>FD 05</b>	13	1400	2000	32	20	<b>FA 05</b>	13	2000	32	21	
0.45		6	920	4.7	66	0.71	3.3	2.0	1.9				2300	3600						3600			
1.1	<b>BN 100LA</b>	4	1450	7.2	74	0.79	5.0	1.7	1.9	82	22	<b>FD 15</b>	26	1400	2000	86	28	<b>FA 15</b>	26	2000	86	29	
0.8		6	950	8.0	65	0.69	4.1	1.9	2.1				2100	3300						3300			
1.5	<b>BN 100LB</b>	4	1450	9.9	75	0.79	5.1	1.7	1.9	95	25	<b>FD 15</b>	26	1300	1800	99	31	<b>FA 15</b>	26	1800	99	32	
1.1		6	950	11.1	72	0.68	4.3	2.0	2.1				2000	3000						3000			
2.3	<b>BN 112M</b>	4	1450	15.2	75	0.78	5.2	1.8	1.9	168	32	<b>FD 06S</b>	40	—	1600	177	42	<b>FA 06S</b>	40	1600	177	44	
1.5		6	960	14.9	73	0.72	4.1	2.0	2.0				—	—	2400				2400				
3.1	<b>BN 132S</b>	4	1460	20	83	0.83	5.9	2.1	2.0	213	44	<b>FD 06</b>	37	—	1200	223	57	<b>FA 06</b>	37	1200	223	58	
2		6	960	20	77	0.75	4.9	2.1	2.1				—	—	1900				1900				
4.2	<b>BN 132MA</b>	4	1460	27	84	0.82	8.8	2.1	2.2	270	53	<b>FD 06</b>	50	—	900	280	66	<b>FA 06</b>	50	900	280	67	
2.6		6	960	26	79	0.72	6.6	2.0	2.0				—	—	1500				1500				

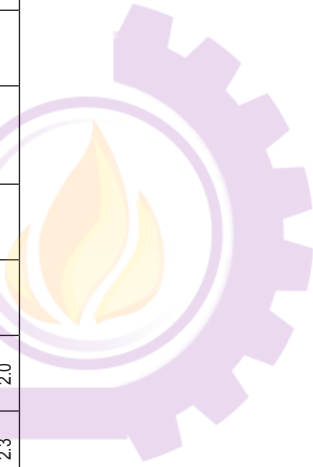

4/8P		1500/750 min <sup>-1</sup> - S1														50 HZ								
		d.c. brake														a.c. brake								
		FD							FA							FA								
P <sub>n</sub> kW		n min <sup>-1</sup>	M <sub>n</sub> Nm	η %	cos φ	I <sub>n</sub> 400V A	$\frac{I_s}{I_n}$	$\frac{M_s}{M_n}$	$\frac{M_a}{M_n}$	J <sub>m</sub> x 10 <sup>-4</sup> kgm <sup>2</sup>	IM B5 	Mod	Mb Nm	Z <sub>0</sub> 1/h	NB	SB	J <sub>m</sub> x 10 <sup>-4</sup> kgm <sup>2</sup>	IM B5 	Mod	Mb Nm	Z <sub>0</sub> 1/h	J <sub>m</sub> x 10 <sup>-4</sup> kgm <sup>2</sup>	IM B5 	
0.37	BN 80A	4	1400	2.5	63	0.82	1.03	3.3	1.4	1.4	15	8.2	FD 04	10	2300	3500	16.6	12.1	FA 04	10	3500	16.6	12.0	12.0
0.18		8	690	2.5	44	0.60	0.98	2.2	1.5	1.6					4500	7000								
0.55	BN 80B	4	1390	3.8	65	0.86	1.42	3.8	1.7	1.6	20	9.9	FD 04	10	2200	2900	22	13.8	FA 04	10	2900	22	13.7	13.7
0.30		8	670	4.3	49	0.65	1.36	2.3	1.7	1.8					4200	6500								
0.65	BN 90S	4	1390	4.5	73	0.85	1.51	4.0	1.9	1.9	28	13.6	FD 14	15	2300	2800	30	17.8	FA 14	15	2800	30	17.7	17.7
0.35		8	690	4.8	49	0.57	1.81	2.5	2.1	2.2					3500	6000								
0.9	BN 90L	4	1370	6.3	73	0.87	2.05	3.8	1.8	1.8	30	15.1	FD 05	26	1700	2100	34	21	FA 05	26	2100	34	22	22
0.5		8	670	7.1	57	0.62	2.04	2.4	2.1	2.0					2500	4200								
1.30	BN 100LA	4	1420	8.7	72	0.83	3.14	4.3	1.7	1.8	82	22	FD 15	40	1300	1700	86	28	FA 15	40	1700	86	29	29
0.70		8	700	9.6	58	0.64	2.72	2.8	1.8	1.8					2000	3400								
1.8	BN 100LB	4	1420	12.1	69	0.87	4.3	4.2	1.6	1.7	95	25	FD 15	40	1200	1700	99	31	FA 15	40	1700	99	32	32
0.9		8	700	12.3	62	0.63	3.3	3.2	1.7	1.8					1600	2600								
2.2	BN 112M	4	1440	14.6	77	0.85	4.9	5.3	1.8	1.8	168	32	FD 06S	60	—	—	177	42	FA 06S	60	1200	177	43	43
1.2		8	710	16.1	70	0.63	3.9	3.3	1.9	1.8					—	—	2000							
3.6	BN 132S	4	1440	24	80	0.82	7.9	6.5	2.1	1.9	295	45	FD 56	75	—	—	305	58	FA 06	75	1000	305	59	59
1.8		8	720	24	72	0.55	6.6	4.6	1.9	2.0					—	—	1400							
4.6	BN 132M	4	1450	30	81	0.83	9.9	6.5	2.2	1.9	383	56	FD 06	100	—	—	393	69	FA 07	100	1000	393	74	74
2.3		8	720	31	73	0.54	8.4	4.4	2.3	2.0					—	—	1300							



2P		3000 min <sup>-1</sup> - S1													50 Hz										
P <sub>n</sub> kW		n min <sup>-1</sup>	M <sub>n</sub> Nm	IE1	η (100%) %	η (75%) %	η (50%) %	cosφ	In 400V A	Is In %	Ms Mn %	Ma Mn %	J <sub>m</sub> x 10 <sup>-4</sup> kgm <sup>2</sup>	IM B5 	d.c. brake					a.c. brake					
															Mod	Mb Nm	Z <sub>o</sub> 1/h	NB	SB	J <sub>m</sub> x 10 <sup>-4</sup> kgm <sup>2</sup>	IM B5 	Mod	Mb Nm	Z <sub>o</sub> 1/h	J <sub>m</sub> x 10 <sup>-4</sup> kgm <sup>2</sup>
0.18	M 05A	2	0.63	○	59.9	56.9	51.9	0.77	0.56	3.0	2.1	2.0	2.0	3.2	FD 02	1.75	3900	4800	2.6	4.9	FA 02	1.75	4800	2.6	4.7
0.25	M 05B	2	0.87	○	66.0	64.8	64.8	0.76	0.72	3.3	2.3	2.3	2.3	3.6	FD 02	1.75	3900	4800	3.0	5.3	FA 02	1.75	4800	3.0	5.1
0.37	M 05C	2	1.26	○	69.1	66.8	66.8	0.78	0.99	3.9	2.6	3.3	3.3	4.8	FD 02	3.5	3600	4500	3.9	6.5	FA 02	3.5	4500	3.9	6.3
0.55	M 15D	2	1.86	○	76.0	75.8	74.8	0.76	1.37	5.0	2.9	4.1	4.1	5.8	FD 03	5	2900	4200	5.3	8.5	FA 03	5	4200	5.3	8.2
0.75	M 15A	2	2.6	○	76.6	76.2	76.2	0.76	1.86	5.1	3.1	5.0	5.0	6.9	FD 03	5	1900	3300	6.1	9.6	FA 03	5	3300	6.1	9.3
1.1	M 25A	2	3.8	●	76.4	76.2	75.0	0.81	2.57	4.8	2.8	2.4	9.0	8.8	FD 04	10	1500	3000	10.6	11.9	FA 04	10	3000	10.6	12.6
1.5	M 25B	2	5.1	●	79.1	79.5	77.2	0.81	3.4	4.9	2.7	2.4	11.4	10.6	FD 04	15	1300	2600	13.0	9.9	FA 04	15	2600	13.0	14.4
2.2	M 35A	2	7.3	●	82.7	82.1	81.0	0.80	4.8	6.3	2.9	2.7	24	15.5	FD 15	26	1100	2400	28	22	FA 15	26	2400	28	23
3	M 35LA	2	10.0	●	81.5	81.3	77.4	0.79	6.7	5.6	2.6	2.2	31	18.7	FD 15	26	700	1600	35	25	FA 15	26	1600	35	26
4	M 35LB	2	13.3	●	83.1	83.0	77.8	0.80	8.7	5.8	2.7	2.5	39	22	FD 15	40	450	900	43	28	FA 15	40	900	43	29
5.5	M 45A	2	18.2	●	84.7	84.5	81.2	0.84	11.2	5.9	2.6	2.2	101	33	FD 06	50	—	600	112	46	FA 06	50	600	112	47
7.5	M 45B	2	25	●	86.5	86.3	84.4	0.85	14.7	6.4	2.6	2.2	145	40	FD 06	50	—	550	154	53	FA 06	50	550	154	54
9.2	M 45LA	2	30	●	87.0	86.5	83.6	0.86	17.7	6.7	2.8	2.3	178	51	FD 06	75	—	430	189	64	FA 06	75	430	189	65
11	M 45LC	2	36	●	87.6	87.0	86.0	0.88	20.6	6.9	2.9	2.5	210	60	FD 56	75	—	—	—	64	FA 06	75	—	—	—
15	M 55B	2	49	●	89.6	89.4	88.0	0.86	28.1	7.1	2.6	2.3	340	70	FD 56	75	—	—	—	64	FA 06	75	—	—	—
18.5	M 55C	2	60	●	90.4	90.1	89.0	0.86	34	7.6	2.7	2.3	420	83	FD 56	75	—	—	—	64	FA 06	75	—	—	—
22	M 55LA	2	72	●	89.9	89.7	89.5	0.88	40	7.8	2.6	2.4	490	95	FD 56	75	—	—	—	64	FA 06	75	—	—	—

○ = n.a. ● = IE1



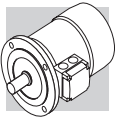

4P		1500 min <sup>-1</sup> - S1																50 Hz												
		d.c. brake																a.c. brake												
		P <sub>n</sub> kW	M <sub>n</sub> Nm	n min <sup>-1</sup>	IE1	η (100%) %	η (75%) %	η (50%) %	cosφ	In 400V A	Is In A	Ms Mn	Ma Mn	J <sub>m</sub> x 10 <sup>-4</sup> kgm <sup>2</sup>	IM B5	Mod	Mb Nm	Z <sub>c</sub> 1/h	NB	SB	J <sub>m</sub> x 10 <sup>-4</sup> kgm <sup>2</sup>	IM B5	Mod	Mb Nm	Z <sub>c</sub> 1/h	J <sub>m</sub> x 10 <sup>-4</sup> kgm <sup>2</sup>	IM B5	FA		
FA	IM B5																													
0.09	M 0B	4	1350	0.64	51.7	47.6	42.9	0.60	0.42	2.6	2.4	1.5	2.9	IM B5		1.75	10000			2.6	4.9		1.75	13000	2.6	4.7	IM B5			
0.12	M 05A	4	1350	0.85	59.8	56.2	47.0	0.62	0.47	2.6	1.8	2.0	3.2	IM B5	FD 02	3.5	10000			3.0	5.3	FA 02	3.5	13000	3.0	5.1	IM B5	FA 02		
0.18	M 05B	4	1320	1.30	54.8	52.9	52.5	0.67	0.71	2.6	2.0	2.3	3.6	IM B5	FD 02	3.5	10000			3.9	6.5	FA 02	3.5	10000	3.9	6.3	IM B5	FA 02		
0.25	M 05C	4	1340	1.78	65.3	65.0	57.9	0.69	0.80	2.7	1.9	3.3	4.8	IM B5	FD 02	5	6000			8.0	8.2	FA 03	5	9400	8.0	7.9	IM B5	FA 03		
0.37	M 15D	4	1370	2.6	66.8	66.7	63.0	0.76	1.05	3.7	2.0	1.9	6.9	IM B5	FD 03	7.5	4300			10.2	9.6	FA 03	7.5	8700	10.2	9.3	IM B5	FA 03		
0.55	M 1LA	4	1380	3.8	69.0	68.9	68.8	0.74	1.55	4.1	2.3	9.1	6.9	IM B5	FD 53	15	4100			22	13.1	FA 04	15	7800	22	13.0	IM B5	FA 04		
0.75	M 2SA	4	1400	5.1	75.0	74.5	69.3	0.78	1.85	4.9	2.7	2.0	9.2	IM B5	FD 04	15	2600			27	14.5	FA 04	15	5300	27	14.4	IM B5	FA 04		
1.1	M 2SB	4	1400	7.5	76.4	76.2	70.4	0.78	2.66	5.1	2.8	2.5	10.6	IM B5	FD 04	26	2800			38	22	FA 15	26	4900	38	23	IM B5	FA 15		
1.5	M 3SA	4	1410	10.2	79.6	80.5	79.3	0.77	3.5	4.6	2.1	34	15.5	IM B5	FD 15	40	2600			44	24	FA 15	40	4700	44	24	IM B5	FA 15		
2.2	M 3LA	4	1410	14.9	81.1	81.4	79.9	0.75	5.2	4.5	2.2	40	17	IM B5	FD 15	40	2400			58	27	FA 15	40	4400	58	28	IM B5	FA 15		
3	M 3LB	4	1410	20	82.6	83.8	83.7	0.77	6.8	5.0	2.3	54	21	IM B5	FD 15	55	—			65	29	FA 15	40	1300	65	30	IM B5	FA 15		
4	M 3LC	4	1400	27	82.7	83.1	80.5	0.78	9.0	4.7	2.3	61	23	IM B5	FD 55	75	—			223	55	FA 06	75	1050	223	56	IM B5	FA 06		
5.5	M 4SA	4	1440	36	84.7	84.8	82.5	0.81	11.6	5.5	2.3	213	42	IM B5	FD 56	100	—			280	64	FA 07	100	950	280	65	IM B5	FA 07		
7.5	M 4LA	4	1440	50	86.0	86.3	85.3	0.81	15.5	5.7	2.4	270	51	IM B5	FD 06	150	—			342	73	FA 07	150	900	342	75	IM B5	FA 07		
9.2	M 4LB	4	1440	61	88.4	88.6	87.5	0.81	18.8	5.9	2.7	319	57	IM B5	FD 07	150	—			382	81	FA 07	150	850	382	83	IM B5	FA 07		
11	M 4LC	4	1440	73	87.6	87.8	86.0	0.81	22.4	6.0	2.7	360	65	IM B5	FD 07	200	—			725	115	FA 08	200	750	725	114	IM B5	FA 08		
15	M 5SB	4	1460	98	88.7	88.5	88.4	0.81	30.1	6.0	2.3	650	85	IM B5	FD 08	250	—			865	131	FA 08	250	700	865	130	IM B5	FA 08		
18.5	M 5LA	4	1460	121	89.3	89.5	89.2	0.81	37	6.2	2.6	790	101	IM B5	FD 08															

○ = n.a.      ● = IE1



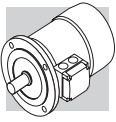

6P		1000 min <sup>-1</sup> - S1													50 Hz														
P <sub>n</sub> kW	Motor Image	n min <sup>-1</sup>	M <sub>n</sub> Nm	IE1	η (100%) %	η (75%) %	η (50%) %	cosφ	I <sub>n</sub> 400V A	I <sub>s</sub> I <sub>n</sub>	M <sub>s</sub> M <sub>n</sub>	M <sub>a</sub> M <sub>n</sub>	J <sub>m</sub> x 10 <sup>-4</sup> kgm <sup>2</sup>	IM B5 Image	d.c. brake					a.c. brake									
															FD		FA			FD		FA							
															Mod	Mb Nm	Z <sub>0</sub> 1/h	J <sub>m</sub> x 10 <sup>-4</sup> kgm <sup>2</sup>	IM B5 Image	Mod	Mb Nm	Z <sub>0</sub> 1/h	J <sub>m</sub> x 10 <sup>-4</sup> kgm <sup>2</sup>	IM B5 Image					
0.09	M 05A	6	0.98	○	41.0	41.0	32.9	0.53	0.60	2.1	2.1	1.8	3.4	4.3	FD 02	3.5	9000	14000	4.0	FA 02	3.5	14000	4.0	6.0	FA 02	3.5	14000	4.0	5.8
0.12	M 05B	6	1.32	○	45.0	44.0	41.8	0.60	0.64	2.1	1.9	1.7	3.7	4.6	FD 02	3.5	9000	14000	4.3	FA 02	3.5	14000	4.3	6.3	FA 02	3.5	14000	4.3	6.1
0.18	M 15C	6	1.91	○	55.0	55.5	51.0	0.69	0.68	2.6	1.9	1.7	8.4	5.1	FD 03	5	8100	13500	9.5	FA 03	5	13500	9.5	7.8	FA 03	5	13500	9.5	7.5
0.25	M 15D	6	2.7	○	62.0	58.5	51.4	0.71	0.82	2.6	1.9	1.7	10.9	6.3	FD 03	5	7800	13000	12	FA 03	5	13000	12	9.0	FA 03	5	13000	12	8.7
0.37	M 1LA	6	3.9	○	66.0	60.0	53.3	0.69	1.17	3.0	2.4	2.0	12.9	7.3	FD 53	7.5	5100	9500	14	FA 03	7.5	9500	14	10.0	FA 03	7.5	9500	14	9.7
0.55	M 25A	6	5.7	○	70.0	69.8	64.3	0.68	1.67	3.9	2.6	2.2	25	10.6	FD 04	15	4800	7200	27	FA 04	15	7200	27	14.5	FA 04	15	7200	27	14.4
0.75	M 25B	6	7.8	●	70.0	70.0	64.4	0.65	2.38	3.8	2.5	2.2	28	11.5	FD 04	15	3400	6400	30	FA 04	15	6400	30	15.4	FA 04	15	6400	30	15.3
1.1	M 35A	6	11.4	●	75.0	74.0	72.0	0.72	2.9	4.3	2.0	1.8	33	17	FD 15	26	2700	5000	37	FA 15	26	5000	37	23	FA 15	26	5000	37	24
1.5	M 3LA	6	15.2	●	75.2	74.2	70.3	0.72	4.0	4.1	2.1	2.0	82	21	FD 15	40	1900	4100	86	FA 15	40	4100	86	27	FA 15	40	4100	86	28
1.85	M 3LB	6	19.0	●	76.6	72.8	62.6	0.73	4.8	4.6	2.1	2.0	95	23	FD 15	40	1700	3600	99	FA 15	40	3600	99	29	FA 15	40	3600	99	30
2.2	M 3LC	6	23	●	77.7	76.8	72.4	0.71	5.8	4.7	2.3	2.1	95	23	FD 55	55	—	1900	99	FA 15	55	1900	99	29	FA 15	55	1900	99	30
3	M 45A	6	30	●	79.7	77.0	75.1	0.76	7.1	5.1	1.9	1.8	216	34	FD 56	75	—	1400	226	FA 06	75	1400	226	47	FA 06	75	1400	226	48
4	M 4LA	6	40	●	81.4	81.5	79.5	0.77	9.2	5.5	2.0	1.8	295	43	FD 06	100	—	1200	305	FA 07	100	1200	305	56	FA 07	100	1200	305	57
5.5	M 4LB	6	56	●	83.1	80.9	79.1	0.78	12.2	6.1	2.1	1.9	383	54	FD 07	150	—	1050	406	FA 07	150	1050	406	70	FA 07	150	1050	406	72
7.5	M 55A	6	75	●	85.0	85.0	84.8	0.81	15.7	5.9	2.2	2.0	740	69	FD 08	170	—	900	815	FA 08	170	900	815	98	FA 08	170	900	815	98
11	M 55B	6	109	●	86.4	86.5	85.9	0.81	22.7	6.6	2.5	2.3	970	89	FD 08	200	—	800	1045	FA 08	200	800	1030	119	FA 08	200	800	1030	118

○ = n.a.      ● = IE1



2/4P		3000/1500 min <sup>-1</sup> - S1														50 Hz									
		d.c. brake														a.c. brake									
		P <sub>n</sub> kW	IM B5	n min <sup>-1</sup>	M <sub>n</sub> Nm	η %	cos φ	I <sub>n</sub> 400V A	I <sub>s</sub> I <sub>n</sub>	M <sub>s</sub> M <sub>n</sub>	M <sub>a</sub> M <sub>n</sub>	J <sub>m</sub> x 10 <sup>-4</sup> kgm <sup>2</sup>	IM B5 Kg	Mod	Mb Nm	Z <sub>0</sub> 1/h	NB	SB	J <sub>m</sub> x 10 <sup>-4</sup> kgm <sup>2</sup>	IM B5 Kg	Mod	Mb Nm	Z <sub>0</sub> 1/h	J <sub>m</sub> x 10 <sup>-4</sup> kgm <sup>2</sup>	IM B5 Kg
FD 02	FD 03																								
0.20	M 05A	2	2700	0.71	55	0.82	0.64	3.5	2.1	1.9	2.9	4.1	FD 02	3.5	2200	2600	2600	3.5	5.8	FA 02	3.5	2600	5100	3.5	5.6
0.15		4	1350	1.06	49	0.67	0.66	2.6	1.8	1.7					4000	5100									
0.28	M 1SB	2	2700	0.99	56	0.82	0.88	2.9	1.9	1.7	4.7	4.0	FD 03	3.5	2100	2400	2400	5.8	6.7	FA 03	3.5	2400	4800	5.8	6.4
0.20		4	1370	1.39	59	0.68	1.02	3.1	1.8	1.7					3800	4800									
0.37	M 1SC	2	2740	1.29	56	0.82	1.16	3.5	1.8	1.8	5.8	4.7	FD 03	5	1400	2100	2100	6.9	7.4	FA 03	5	2100	4200	6.9	7.1
0.25		4	1390	1.72	60	0.73	0.82	3.3	2.0	1.9					2900	4200									
0.45	M 1SD	2	2780	1.55	63	0.85	1.21	3.8	1.8	1.8	6.9	5.5	FD 03	5	1400	2100	2100	8.0	8.2	FA 03	5	2100	4200	8.0	7.9
0.30		4	1400	2.0	63	0.74	0.93	3.8	2.1	1.9					2800	4200									
0.55	M 1LA	2	2800	1.9	73	0.79	1.38	4.2	2.0	1.8	9.1	6.9	FD 03	5	1600	2200	2200	10.2	9.6	FA 03	5	2200	4600	10.2	9.3
0.37		4	1400	2.5	68	0.72	1.09	3.9	2.2	2.0					3300	4600									
0.75	M 2SA	2	2780	2.6	65	0.85	1.96	3.8	1.9	1.8	20	9.2	FD 04	10	1400	1600	1600	22	13.1	FA 04	10	1600	3600	22	13.0
0.55		4	1400	3.8	68	0.81	1.44	3.9	1.7	1.7					2700	3600									
1.1	M 2SB	2	2730	3.9	65	0.86	2.84	3.9	2.0	1.9	25	10.7	FD 04	10	1200	1500	1500	27	14.5	FA 04	10	1500	3100	27	14.5
0.75		4	1410	5.1	75	0.81	1.78	4.5	2.1	2.0					2300	3100									
1.5	M 3SA	2	2830	5.1	74	0.83	3.5	4.7	2.1	2.0	34	15.5	FD 15	26	700	1000	1000	38	22	FA 15	26	1000	2600	38	23
1.1		4	1420	7.4	77	0.78	2.6	4.3	2.1	2.0					1600	2600									
2.2	M 3LA	2	2800	7.5	72	0.85	5.2	4.5	2.0	1.9	40	17	FD 15	26	600	900	900	44	24	FA 15	26	900	2300	44	24
1.5		4	1410	10.2	73	0.79	3.8	4.7	2.0	2.0					1300	2300									
3.5	M 3LB	2	2850	11.7	80	0.84	7.5	5.4	2.2	2.1	61	23	FD 15	40	500	900	900	65	29	FA 15	40	900	2100	65	30
2.5		4	1420	16.8	82	0.80	5.5	5.2	2.2	2.2					1000	2100									
4.8	M 4 SA	2	2900	15.8	81	0.88	9.7	6.0	2.0	1.9	213	42	FD 06	50	—	400	400	233	55	FA 06	50	400	950	233	56
3.8		4	1430	25.4	81	0.84	8.1	5.2	2.1	2.1					—	950	—								
5.5	M 4SB	2	2890	18.2	80	0.87	11.4	5.9	2.4	2.0	213	42	FD 06	75	—	350	350	223	55	FA 06	75	350	900	223	56
4.4		4	1440	29	82	0.84	9.2	5.3	2.2	2.0					—	900	—								
7.5	M 4LA	2	2900	25	82	0.87	15.2	6.5	2.4	2.0	270	51	FD 06	100	—	350	350	280	64	FA 07	100	350	950	280	65
6		4	1430	40	84	0.85	12.1	5.8	2.3	2.1					—	950	—								
9.2	M 4LB	2	2920	30	83	0.86	18.6	6.0	2.6	2.2	319	57	FD 07	150	—	300	300	342	73	FA 07	150	300	800	342	75
7.3		4	1440	48	85	0.85	14.6	5.5	2.3	2.1					—	800	—								

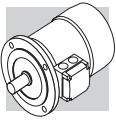

**2/6P** **3000/1000 min-1 - S3 60/40%** **50 Hz**

P <sub>n</sub> kW			n min <sup>-1</sup>	M <sub>n</sub> Nm	η %	cosφ	I <sub>n</sub> 400V A	I <sub>s</sub> I <sub>n</sub>	M <sub>s</sub> M <sub>n</sub>	M <sub>a</sub> M <sub>n</sub>	J <sub>m</sub> x 10 <sup>-4</sup> kgm <sup>2</sup>	IM B5 	d.c. brake						a.c. brake														
													FD			FA			FD			FA											
													Mod	Mb Nm	Z <sub>0</sub> 1/h	NB	SB	Mod	Mb Nm	Z <sub>0</sub> 1/h	IM B5 	J <sub>m</sub> x 10 <sup>-4</sup> kgm <sup>2</sup>	Mod	Mb Nm	Z <sub>0</sub> 1/h	IM B5 	J <sub>m</sub> x 10 <sup>-4</sup> kgm <sup>2</sup>						
0.25	<b>M 1SA</b>	2	2850	0.84	60	0.82	0.73	4.3	1.9	1.8	6.9	5.5	FD 03	1.75	1500	1700	10000	9000	11000	FA 03	1.75	1700	13000	13000	FA 03	1.75	1700	8.0	8.0	7.9			
0.08		6	910	0.84	43	0.70	0.38	2.1	1.4	1.5																							
0.37	<b>M 1LA</b>	2	2880	1.23	62	0.80	1.08	4.4	1.9	1.8	9.1	6.9	FD 03	3.5	1000	1300	10000	9000	11000	FA 03	3.5	1300	13000	13000	FA 03	3.5	1300	10.2	10.2	9.3			
0.12		6	900	1.27	44	0.73	0.54	2.4	1.4	1.5																							
0.55	<b>M 2SA</b>	2	2800	1.88	63	0.86	1.47	4.5	1.9	1.7	20	9.2	FD 04	5	1500	1800	10000	9000	11000	FA 04	5	1800	13000	13000	FA 04	5	1800	22	22	13.0			
0.18		6	930	1.85	52	0.65	0.77	3.3	2.0	1.9																							
0.75	<b>M 2SB</b>	2	2800	2.6	66	0.87	1.89	4.3	1.8	1.6	25	10.6	FD 04	5	1700	1900	10000	9000	11000	FA 04	5	1900	13000	13000	FA 04	5	1900	27	27	14.4			
0.25		6	930	2.6	54	0.67	1.00	3.2	1.7	1.8																							
1.1	<b>M 3SA</b>	2	2870	3.7	71	0.82	2.73	4.9	1.8	1.9	34	15.5	FD 15	13	1000	1300	10000	9000	11000	FA 15	13	1300	13000	13000	FA 15	13	1300	38	38	23			
0.37		6	930	3.8	63	0.70	1.21	3.1	1.5	1.8																							
1.5	<b>M 3LA</b>	2	2880	5.0	73	0.84	3.53	5.1	1.9	2.0	40	17	FD 15	13	1000	1200	10000	9000	11000	FA 15	13	1200	13000	13000	FA 15	13	1200	44	44	24			
0.55		6	940	5.6	64	0.67	1.85	3.5	1.7	1.8																							
2.2	<b>M 3LB</b>	2	2900	7.2	77	0.85	4.9	5.9	2.0	2.0	61	23	FD 15	26	700	900	10000	9000	11000	FA 15	26	900	13000	13000	FA 15	26	900	65	65	30			
0.75		6	950	7.5	67	0.64	2.5	3.3	1.9	1.8																							
3	<b>M 4SA</b>	2	2910	9.9	74	0.88	6.6	5.6	2.0	2.1	170	36	FD 56	37	—	600	10000	9000	11000	FA 56	37	600	13000	13000	FA 56	37	600	182	182	50			
1.1		6	960	10.9	73	0.68	3.2	4.5	2.2	2.0																							
4.5	<b>M 4SB</b>	2	2910	14.8	78	0.84	9.9	5.8	1.9	1.8	213	42	FD 56	37	—	500	10000	9000	11000	FA 56	37	500	13000	13000	FA 56	37	500	223	223	56			
1.5		6	960	14.9	74	0.67	4.4	4.2	1.9	2.0																							
5.5	<b>M 4LA</b>	2	2920	18.0	78	0.87	11.7	6.2	2.1	1.9	270	51	FD 06	50	—	400	10000	9000	11000	FA 06	50	400	13000	13000	FA 06	50	400	280	280	65			
2.2		6	960	22	77	0.71	5.8	4.3	2.1	2.0																							



2/8P		3000/750 min <sup>-1</sup> - S3 60/40%														50 Hz									
		d.c. brake														a.c. brake									
		P <sub>n</sub> kW	IM B5	n min <sup>-1</sup>	M <sub>n</sub> Nm	η %	cos φ	I <sub>n</sub> 400V A	I <sub>s</sub> I <sub>n</sub>	M <sub>s</sub> M <sub>n</sub>	M <sub>a</sub> M <sub>n</sub>	J <sub>m</sub> x 10 <sup>-4</sup> kgm <sup>2</sup>	IM B5 Kg	Mod	Mb Nm	Z <sub>o</sub> 1/h	NB	SB	J <sub>m</sub> x 10 <sup>-4</sup> kgm <sup>2</sup>	IM B5 Kg	Mod	Mb Nm	Z <sub>o</sub> 1/h	J <sub>m</sub> x 10 <sup>-4</sup> kgm <sup>2</sup>	IM B5 Kg
FD 03	FD 04																								
0.37	M 1LA	2	2800	1.26	63	0.86	0.99	3.9	1.8	1.9	12.9	7.3	FD 03	3.5	1200	1300	13000	14	10.0	FA 03	3.5	1300	13000	14	9.7
0.09		8	670	1.28	34	0.75	0.51	1.8	1.4	1.5					9500										
0.55	M 2SA	2	2830	1.86	66	0.86	1.40	4.4	2.1	2.0	20	9.2	FD 04	5	1500	1800	8000	22	13.1	FA 04	5	1800	8000	22	13.0
0.13		8	690	1.80	41	0.64	0.72	2.3	1.6	1.7					5600										
0.75	M 2SB	2	2800	2.6	68	0.88	1.81	4.6	2.1	2.0	25	10.6	FD 04	10	1700	1900	7300	27	14.5	FA 04	10	1900	7300	27	14.4
0.18		8	690	2.5	43	0.66	0.92	2.3	1.6	1.7					4800										
1.1	M 3SA	2	2870	3.7	69	0.84	2.74	4.6	1.8	1.7	34	15.5	FD 15	13	1000	1300	5000	38	22	FA 15	13	1300	5000	38	23
0.28		8	690	3.9	44	0.56	1.64	2.3	1.4	1.7					3400										
1.5	M 3LA	2	2880	5.0	69	0.85	3.69	4.7	1.9	1.8	40	17	FD 15	13	1000	1200	5000	44	24	FA 15	13	1200	5000	44	24
0.37		8	690	5.1	46	0.63	1.84	2.1	1.6	1.6					3300										
2.4	M 3LB	2	2900	7.9	75	0.82	5.6	5.4	2.1	2.0	61	23	FD 15	26	550	700	3500	65	29	FA 15	26	700	3500	65	30
0.55		8	700	7.5	54	0.58	2.5	2.6	1.8	1.8					2000										
3	M 4SA	2	2920	9.8	72	0.85	7.1	5.6	2.0	1.8	162	36	FD 56	37	—	600	3400	182	48	FA 06	37	600	3400	182	50
0.75		8	710	10.1	61	0.64	2.8	3.0	1.7	1.8					—	—	—	—	—	—	—	—	—	—	—
4	M 4SB	2	2870	13.3	73	0.84	9.4	5.6	2.3	2.4	213	42	FD 56	37	—	500	3500	223	55	FA 06	37	500	3500	223	56
1		8	690	13.8	66	0.62	3.5	2.9	1.9	1.8					—	—	—	—	—	—	—	—	—	—	—
5.5	M 4LA	2	2870	18.3	75	0.84	12.6	6.1	2.4	2.5	270	51	FD 06	50	—	400	2400	280	64	FA 06	50	400	2400	280	65
1.5		8	690	21	68	0.63	5.1	2.9	1.9	1.9					—	—	—	—	—	—	—	—	—	—	—

**2/12P** **3000/500 min<sup>-1</sup> - S3 60/40%** **50 Hz**

P <sub>n</sub> kW		n min <sup>-1</sup>	M <sub>n</sub> Nm	η %	cos φ	I <sub>n</sub> 400V A	$\frac{I_s}{I_n}$	$\frac{M_s}{M_n}$	$\frac{M_a}{M_n}$	J <sub>m</sub> x 10 <sup>-4</sup> kgm <sup>2</sup>	IM B5 	d.c. brake						a.c. brake					
												FD			FA			FD			FA		
												Mod	Mb	Z <sub>0</sub> 1/h	NB	SB	Mod	Mb	Z <sub>0</sub> 1/h	IM B5 	J <sub>m</sub> x 10 <sup>-4</sup> kgm <sup>2</sup>	Mod	Mb
0.55	M 2SA	2	1.86	64	0.89	1.39	4.2	1.6	1.7	25	10.6	FD 04	5	1000	1300	1300	14.5	27	1300	5	1300	27	14.4
0.09		12	2.0	30	0.63	0.69	1.8	1.9	1.8					8000	12000	12000							
0.75	M 3SA	2	2.5	65	0.81	2.06	5.2	1.9	2.1	34	15.5	FD 15	13	700	900	900	22	38	900	13	900	38	23
0.12		12	2.5	33	0.43	1.22	1.9	1.3	1.6					5000	7000	7000							
1.1	M 3LA	2	3.7	65	0.85	2.87	4.5	1.6	1.8	40	17	FD 15	13	700	900	900	24	44	900	13	900	44	24
0.18		12	4.0	26	0.54	1.85	1.5	1.3	1.5					4000	6000	6000							
1.5	M 3LB	2	4.9	67	0.86	3.76	5.6	1.9	1.9	54	21	FD 15	13	700	900	900	27	58	900	13	900	58	28
0.25		12	5.4	36	0.46	2.18	1.8	1.7	1.8					3800	5000	5000							
2	M 3LC	2	6.7	70	0.84	4.9	4.9	1.8	1.7	61	23	FD 55	18	—	700	700	29	65	700	18	700	65	30
0.3		12	6.4	38	0.47	2.4	1.7	1.6	1.7					—	3500	3500							
3	M 4SA	2	9.8	74	0.87	6.7	6.8	2.3	1.9	213	42	FD 56	37	—	450	450	55	223	450	37	450	223	56
0.5		12	10.2	51	0.43	3.3	2.0	1.7	1.6					—	3000	3000							
4	M 4LA	2	13.1	75	0.89	8.6	5.9	2.4	2.3	270	51	FD 56	37	—	400	400	64	280	400	37	400	280	65
0.7		12	14.5	53	0.44	4.3	1.9	1.7	1.6					—	2800	2800							

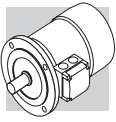

M11 MOTORS DIMENSIONS

BN - IM B5

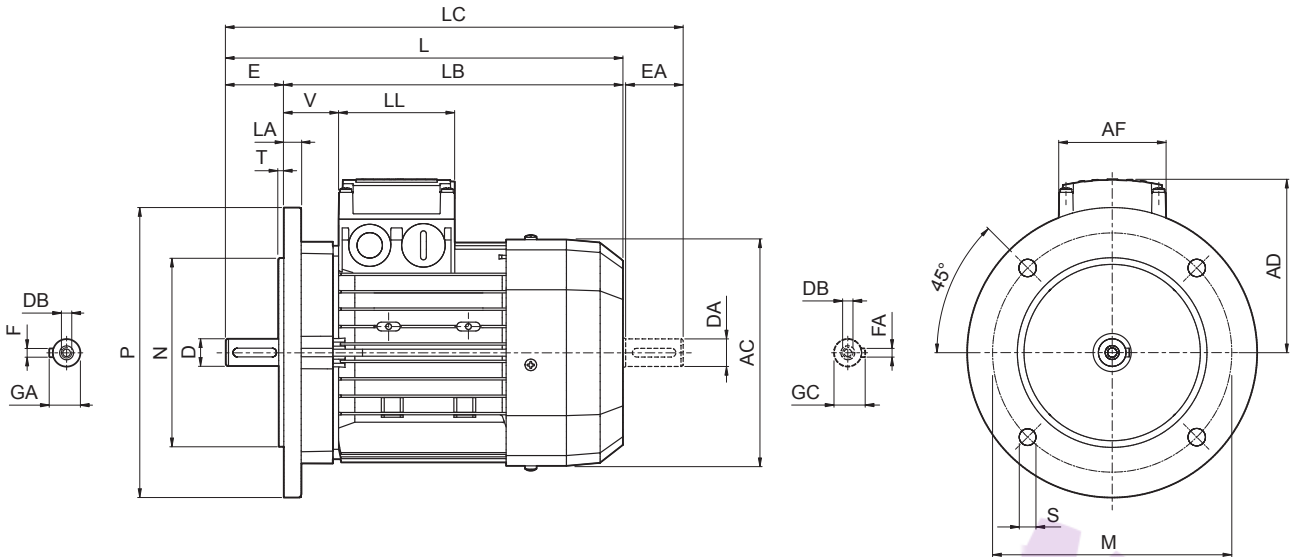

	Shaft					Flange					Motor									
	D DA	E EA	DB	GA GC	F FA	M	N	P	S	T	LA	AC	L	LB	LC	AD	AF	LL	V	
BN 56	9	20	M3	10.2	3	100	80	120	7	3	8	110	185	165	207	91	74	80	34	
BN 63	11	23	M4	12.5	4	115	95	140	9.5			10	121	207	184	232			95	26
BN 71	14	30	M5	16	5	130	110	160				10	138	249	219	281			108	37
BN 80	19	40	M6	21.5	6	165	130	200	11.5	3.5	11.5	156	274	234	315	119	98	98	38	
BN 90	24	50	M8	27	8							176	326	276	378	133			44	
BN 100	28	60	M10	31	8	215	180	250	14	4	14	195	367	307	429	142	118	118	50	
BN 112												15	219	385	325	448			157	52
BN 132												20	258	493	413	576			193	58
BN 160 MR	42 38 (1)	110 80 (1)	M16 M12 (1)	45 41 (1)	12 10 (1)	300	250	350	18.5	5	15	310	562	452	645	245	187	187	218	
BN 160 M												310	596	486	680	51				
BN 160 L												310	640	530	724	51				
BN 180 M	48 38 (1)	110 110 (1)	M16 M12 (1)	51.5 41 (1)	14 10 (1)	350	300	400	18.5	5	18	348	708	598	823	261	187	187	52	
BN 180 L	42 (1)											722	612	837	66					
BN 200 L	55 42 (1)											M20 M16 (1)	59 45 (1)	16 12 (1)	66					

NOTE:

1) These values refer to the rear shaft end.

## BN\_FD ; IM B5

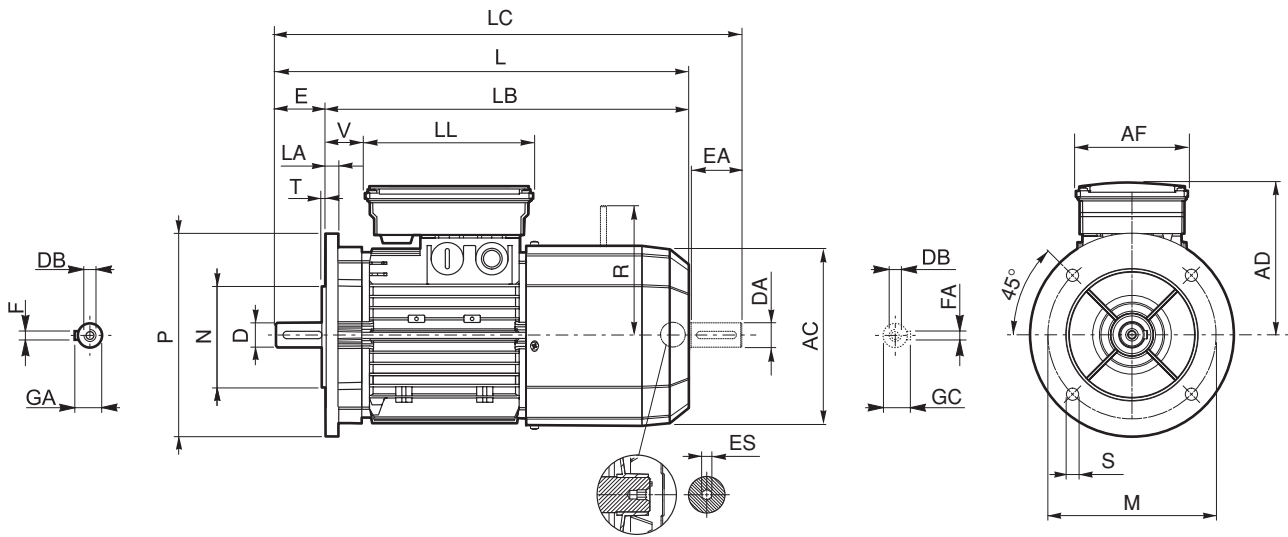

	Shaft					Flange					Motor											
	D DA	E EA	DB	GA GC	F FA	M	N	P	S	T	LA	AC	L	LB	LC	AD	AF	LL	V	R	ES	
<b>BN 63</b>	11	23	M4	12.5	4	115	95	140	9.5	3	10	121	272	249	297	122	98	133	14	96	5	
<b>BN 71</b>	14	30	M5	16	5	130	110	160	9.5	3.5		138	310	280	342	135			25	103		
<b>BN 80</b>	19	40	M6	21.5	6	165	130	200	11.5			41	129									
<b>BN 90 S</b>	24	50	M8	27	8	215	180	250	14	4	11.5	176	409	359	461	149	110	165	39	160	6	
<b>BN 90 L</b>												146	62									
<b>BN 100</b>	28	60	M10	31	8	215	180	250	14	4	11.5	14	195	458	398	521	158	110	165	62	160	6
<b>BN 112</b>												15	219	484	424	547	173		73	199		
<b>BN 132</b>	38	80	M12	41	10	265	230	300	18.5	5	20	258	603	523	686	210	140	188	46	204 (2)	6	
<b>BN 160 MR</b>	42	110	M16	45	12	300	250	350					672	562	755				161	226		
<b>BN 160 M</b>	38 (1)	80 (1)	M12 (1)	41 (1)	10 (1)				300	250	350	18.5	5	15	310	736	626	820	245	187	187	51
<b>BN 160 L</b>	42	110	M16	45	12	300	250	350								18.5	5	15				310
<b>BN 180 M</b>	48	80 (1)	M12 (1)	51.5	14				350	300	400	18.5	5	18	348				866	756	981	
<b>BN 180 L</b>	48	110	M16 (1)	45 (1)	12 (1)	350	300	400								18.5	5	18	348	878	768	993
<b>BN 200 L</b>	55	110 (1)	M20	59	16				350	300	400	18.5	5	18	348					878	768	993
	42 (1)		M16 (1)	45 (1)	12 (1)																	

NOTE:

- 1) These values refer to the rear shaft end.
- 2) For FD07 brake value R=226.

ES hexagon is not supplied with PS option.



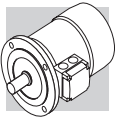

**BN\_FA - IM B5**

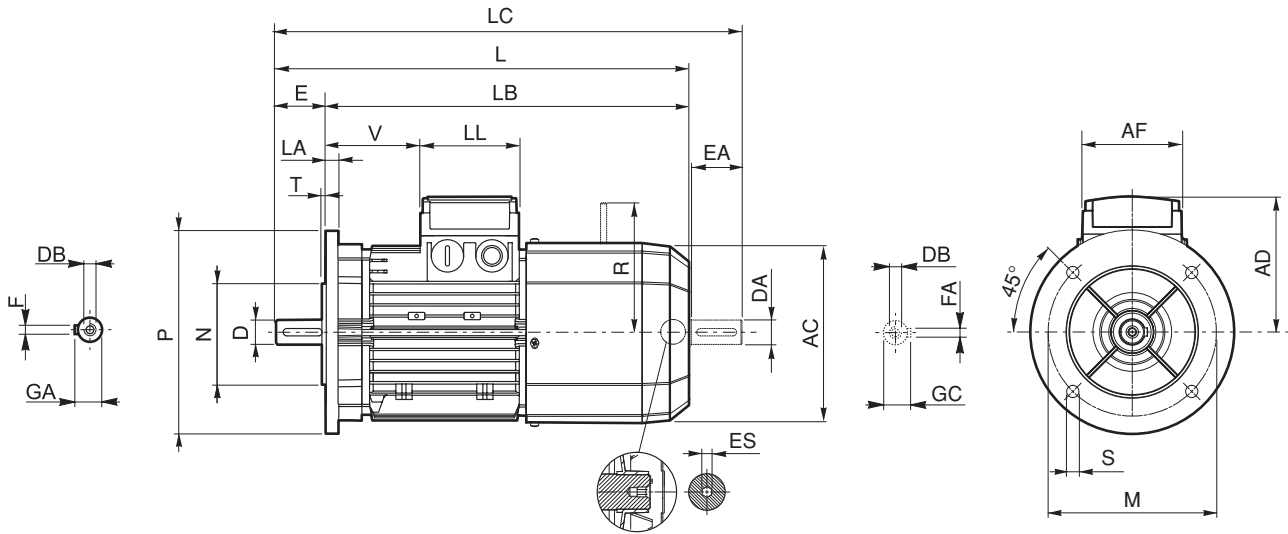

	Shaft					Flange					Motor										
	D DA	E EA	DB	GA GC	F FA	M	N	P	S	T	LA	AC	L	LB	LC	AD	AF	LL	V	R	ES
<b>BN 63</b>	11	23	M4	12.5	4	115	95	140	9.5	3	10	121	272	249	297	95	74	80	26	116	5
<b>BN 71</b>	14	30	M5	16	5	130	110	160				138	310	280	342	108			68	124	
<b>BN 80</b>	19	40	M6	21.5	6	165	130	200	11.5	3.5	11.5	156	346	306	388	119	98	98	83	134	6
<b>BN 90</b>	24	50	M8	27	8							176	409	359	461	133			95	160	
<b>BN 100</b>	28	60	M10	31	8	215	180	250	14	4	14	195	458	398	521	142	98	98	119	198	6
<b>BN 112</b>												15	219	484	424	547			157	128	
<b>BN 132</b>	38	80	M12	41	10	265	230	300	14	5	20	258	603	523	686	210	140	188	46	200 (2)	6
<b>BN 160 MR</b>	42 38 (1)	110 80 (1)	M16 M12 (1)	45 41 (1)	12 10 (1)	300	250	350					18.5	5	15	310	672	562	755	193	
<b>BN 160 M</b>									736	626	820	245					187	187	51	247	
<b>BN 160 L</b>									780	670	864										
<b>BN 180 M</b>												51.5 41 (1)					14 10 (1)				

**NOTE:**

- 1) These values refer to the rear shaft end.
- 2) For FA07 brake value R=217.

Dimensions AD, AF, LL and V, relevant to terminal box of motors BN...FA featuring the separate brake supply (option SA), are coincident with corresponding dimensions of same-size BN...FD motors

ES hexagon is not supplied with PS option.

**M**

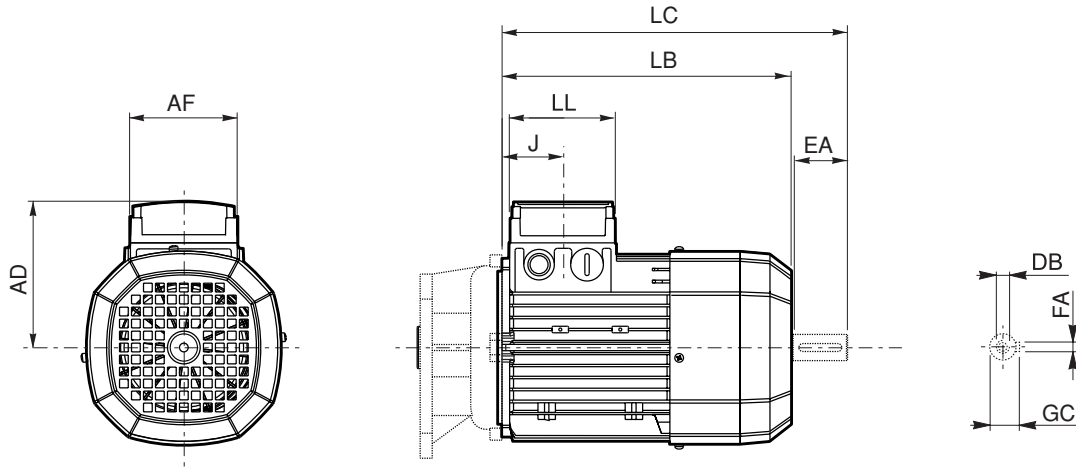

	Rear shaft end					Motor						
	DA	EA	DB	FA	GC	AC	LB	LC	AF	LL	J	AD
<b>M 0</b>	9	20	M3	3	10.2	110	133	155	74	80	42	91
<b>M 05</b>	11	23	M4	4	12.5	121	165	191			48	95
<b>M 1</b>	14	30	M5	5	16	138	187	219			45	108
<b>M 2 S</b>	19	40	M6	6	21.5	156	202	245			44	119
<b>M 3 S</b>	28	60	M10	8	31	195	230	293	98	98	53.5	142
<b>M 3 L</b>							262	325				
<b>M 4</b>	38	80	M12	10	41	258	361	444	118	118	64.5	193
<b>M 4 LC</b>							396	479				
<b>M 5 S</b>						310	418	502	187	187	77	245
<b>M 5 L</b>							462	546				

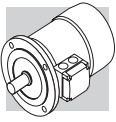

M\_FD

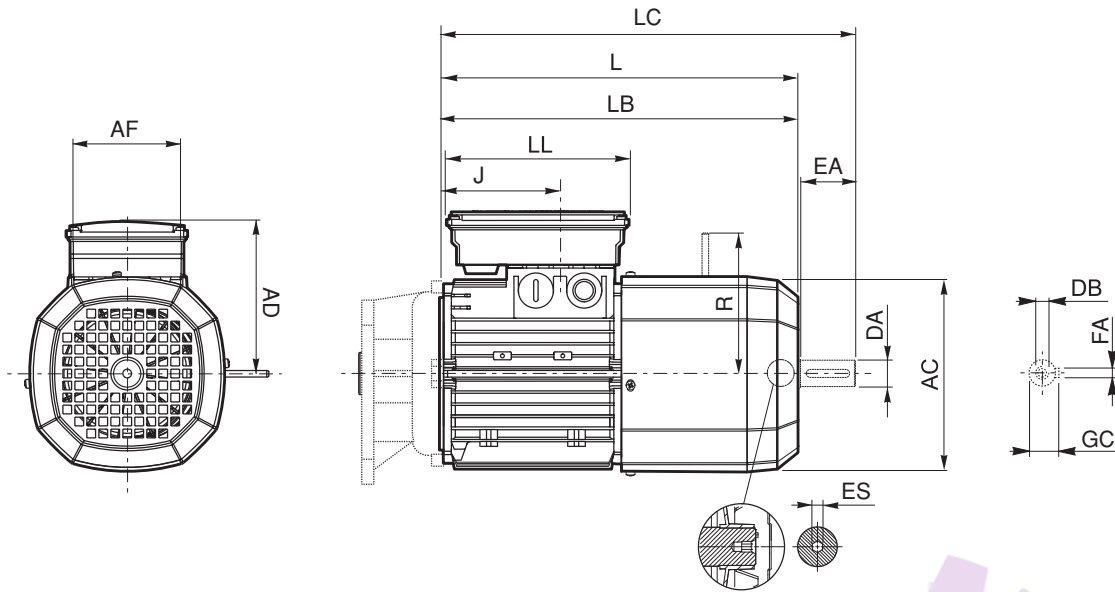

	Rear shaft end					Motor								
	DA	EA	DB	FA	GC	AC	LB	LC	AF	LL	J	AD	R	ES
M 05	11	23	M4	4	12.5	121	231	256	98	133	48	122	96	5
M 1	14	30	M5	5	16	138	248	280			73	135	103	
M 2 S	19	40	M6	6	21.5	156	272	314			88	146	129	
M 3 S	28	60	M10	8	31	195	326	389	110	165	124.5	158	160	6
M 3 L							353	416						
M 4	38	80	M12	10	41	258	470	553	140	188	185.5	210	204 (1)	
M 4 LC							495	578			64.5		226	
M 5 S						310	558	642	187	187	77	245	266	—
M 5 L	602	686												

NOTE:

1) For FD07 brake value R=226.

ES hexagon is not supplied with PS option.

## M\_FA

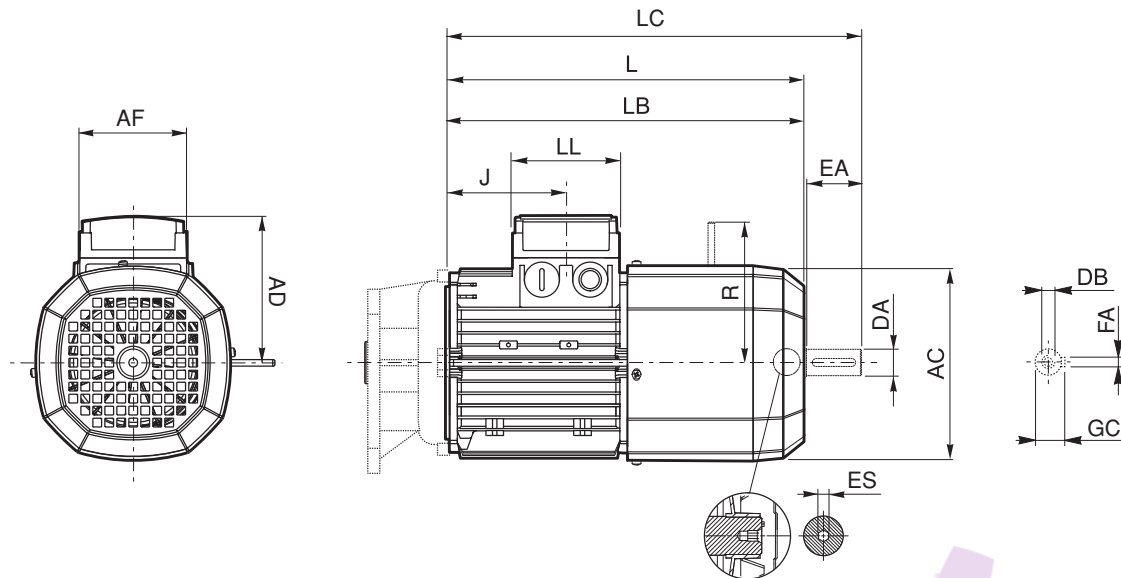

	Rear shaft end					Motor								
	DA	EA	DB	FA	GC	AC	LB	LC	AF	LL	J	AD	R	ES
<b>M 05</b>	11	23	M4	4	12.5	121	231	256	74	80	48	95	116	5
<b>M 1</b>	14	30	M5	5	16	138	248	280			73	108	124	
<b>M 2 S</b>	19	40	M6	6	21.5	156	272	314			88	119	134	
<b>M 3 S</b>	28	60	M10	8	31	195	326	389	98	98	124.5	142	160	6
<b>M 3 L</b>							353	416						
<b>M 4</b>	38	80	M14	10	41	258	470	553	140	188	185.5	210	200 (1)	
<b>M 4 LC</b>							495	578			64.5		217	
<b>M 5 S</b>			M12			310	558	642	187	187	77	245	247	—
<b>M 5 L</b>	602	686												

**NOTE:**

1) For FA07 brake value R=217.

Dimensions AD, AF, LL and V, relevant to terminal box of motors M...FA featuring the separate brake supply (option SA), are coincident with corresponding dimensions of same-size M...FD motors

ES hexagon is not supplied with PS option.

## INDEX OF REVISIONS

BR_CAT_CAFS_STD_ENG_R08_0	
	Description
33, 34	Fixed gearmotor rating charts for rated power of 0.09 kW
299	Unified dimensions of protection cover for US shaft on A50 gearbox
307 ... 316	Amended drawings of gearboxes A60 US, A70 US, A80 US, A90 US
521	Updated table "Frequency" F16



آتور صنعت

ATOORSANAT





Bonfiglioli has been designing and developing innovative and reliable power transmission and control solutions for industry, mobile machinery and renewable energy applications since 1956.

**HEADQUARTERS**

Bonfiglioli Riduttori S.p.A.  
Via Giovanni XXIII, 7/A  
40012 Lippo di Calderara di Reno  
Bologna (Italy)

tel: +39 051 647 3111  
fax: +39 051 647 3126  
bonfiglioli@bonfiglioli.com  
www.bonfiglioli.com

BR\_CAT\_CAF5\_STD\_ENG\_R08\_0

